



Volume 1 (2024)



**KENNIONS**  
*LOCOMOTIVES*

# Catalogue

**MODEL STEAM LOCOMOTIVE &  
STATIONARY ENGINE  
DRAWINGS & CASTINGS**

**Includes our range of:**

O Gauge,  
2 1/2" Gauge,  
3 1/2" Gauge,  
5" Gauge,  
7 1/4" Gauge,  
Stationary Engines  
& Models

Butch 5" Tank Loco



**A Division of:**

**EKP**  
**SUPPLIES**

**[WWW.KENNIONS.CO.UK](http://WWW.KENNIONS.CO.UK)**

Tel: 01271 346 441

E: [sales@ekpsupplies.com](mailto:sales@ekpsupplies.com)

# Terms & Conditions

## **Pricing & Ordering:**

For current pricing please see our website [www.kennions.co.uk](http://www.kennions.co.uk) or separate price list. All prices quoted are correct at time of printing exclude VAT at the current rate. We reserve the right to change prices without notice due to circumstances beyond our control. We have a minimum order value of £5.00 before postage and VAT applicable to all orders. Orders can be placed online or over the phone.

## **Store Collection & Opening Hours:**

We are open Monday to Friday 09:00 - 16:30. We are closed on bank holidays. Outside of these hours orders can be placed via our website and will be processed upon our return.

We are now able to offer a collection service from our new unit address

## **Product Description & Availability**

Whilst every care has been taken to ensure all product details are correct, any errors are unintentional and will be amended once aware. Illustrations, drawings dimensions and weights are to be regarded as guidance only and cannot be held binding in any way. We cannot be held responsible for errors or omissions and / or time lost or any other costs so resulting. We reserve the right to alter pattern designs without notice. We make every effort to ensure all items are in stock, if any items are not available at time of ordering we are happy to back order these for yourself and will dispatch the order as quickly as possible. Any item listed without a product code are items we are adding to the range, please check our website for further details.

All castings listed will be supplied in Gun Metal unless specified (CI = Cast Iron, AL—Aluminium)

## **Payment:**

Full payment for all orders is required before goods are dispatched. Please note that we are no longer able to accept cheque payments. We are able to accept Visa and Mastercard credit and debit cards, American Express, PayPal, and BACS payment methods.

## **Postage and Packing Charges (UK Mainland Only):**

Postage and packaging is calculated based on size and approximate weight of the parcel;

|                | Standard Royal Mail | Recorded Royal Mail | Courier |
|----------------|---------------------|---------------------|---------|
| Upto 400g:     | £3.25               | £4.95               | £8.75   |
| 400g to 675g:  | £4.25               | £5.95               | £8.75   |
| 675g to 1750g: | £5.25               | £6.75               | £8.75   |
| 1750g to 20kg  | -                   | -                   | £8.75   |
| 20kg to 25kg   |                     |                     | £9.75   |
| 25kg to 40kg   |                     |                     | £11.50  |

Items over 400mm (16") can only be shipped by courier.

For Items over 1750g sent to the Scottish Highlands, Offshore Islands or Remote Areas (full location list can be found via our website), we are able to ship via Royal Mail Recorded service up to maximum value of £100.00 and weight of 9.5kg for a cost of £11.50, if you would prefer for your order be dispatched by courier please contact us. International Shipping is available, please contact us for details. Exclusions apply.

## **Cancellations & Return Policy:**

Orders cannot be cancelled once an order has been dispatched by us.

Products may be returned to us for refund by way of the following procedure

- A returns number or authorisation number is required by us prior to return the goods
- Products must be returned unused, in their original packaging and in a condition that is immediately fit for resale
- Returns must be made within 14 days of the invoice date unless special authorisation has been agreed
- If a casting is found to be faulty, we will exchange it free or charge upon receipt of the faulty casting. We are not responsible for any carriage charges or machining costs.

## About Us



With over 30 years experience, we are the leading manufacturers of precision turned screws and parts for the model engineer, and engineering trades, in the UK. We are a family run company who have successfully established ourselves with a record for fantastic customer service and quality products. As a family with keen engineering interests ourselves, we saw a market for precision turned screws over the more commonly “pressed threads”. Over the years, the range of sizes and variations has grown and we are now stock and offer over 1000 different sizes.

Along with our vast range of fastenings, we are able to offer various materials, tools, steam fittings, lubricants, and soldering products. This makes us a one stop shop for the majority of your engineering needs. If there are any items you are unable to locate via in our catalogues or on our website please do not hesitate to contact us and we will do all we can to assist.

All of our own products are manufactured to the highest quality using traditional engineering methods. We do also stock a range of quality products for other UK suppliers and manufacturers to complement our offering.

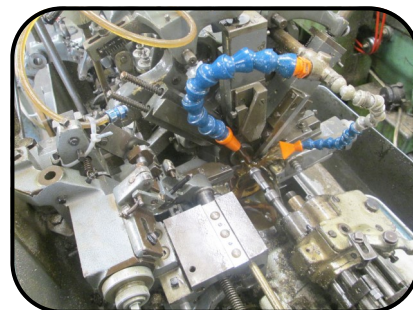

During early 2021, we made the move to a larger purpose designed factory including a customer counter, this allows us to now be able to accept walk in customers and also offer a click and collect service via our website.

In September 2023, we were very pleased to announce the acquisition of Kennions Locomotives and Stationary Engines, with the rights to over 60 engines. Having worked with Richard over the years we had built up a respectful working relationship which allowed Richard reassurance that the brand will be kept safe and available for years to come. Kennions is one of the oldest suppliers in the UK dating back to the early 1900's and we hope to be able to keep this name in the industry for many years to come and to re-introduce some “lost” engines



We pride ourselves on our quality service and competitive pricing and hope to be able to help you with your engineering needs for years to come.

Orders for any of the castings, materials, fastenings or more can be placed online via our website, via email or over the phone with one of our sales team.

# Contents

| Products                        | Page No.       |
|---------------------------------|----------------|
| <b>'O' Gauge Locomotives</b>    | <b>4 - 6</b>   |
| - BAT                           | 4              |
| - Hertford Hall                 | 4              |
| - Josie                         | 5              |
| - Princess Coronation           | 5              |
| - Royal Scot                    | 6              |
| - Sir Morris De Cowley          | 6              |
| <b>2 1/2" Gauge Locomotives</b> | <b>7 - 14</b>  |
| - Austere Ada                   | 7              |
| - Dyak                          | 8              |
| - Fayette                       | 9              |
| - GWR Saddle Tank               | 10             |
| - Olympiade                     | 11             |
| - Purley Grange                 | 12             |
| - S15                           | 13             |
| - Southern Maid                 | 14             |
| <b>3 1/2" Gauge Locomotives</b> | <b>15 - 37</b> |
| - Bantam Cock                   | 15             |
| - Britannia                     | 16             |
| - Canterbury Lamb               | 17             |
| - City of Truro                 | 18             |
| - Doris                         | 19             |
| - Hielan Lassie                 | 20             |
| - Iris                          | 21             |
| - Juliet - Inside Motion        | 22             |
| - Juliet - Outside Motion       | 23             |
| - Maisie                        | 24             |
| - Miss 10 to 8                  | 25             |
| - Molly                         | 26             |
| - Mona                          | 27             |
| - Northumbrian                  | 28             |
| - Pamela                        | 29             |
| - Petrolea                      | 30             |
| - PV Baker                      | 31             |
| - Rainhill                      | 32             |
| - Rob Roy                       | 33             |
| - Royal Scot                    | 34             |
| - Tich - Large Boiler           | 35             |
| - Tich - Small Boiler           | 36             |
| - Virginia                      | 37             |

# Contents

| Products                             | Page No.       |
|--------------------------------------|----------------|
| <b>5" Gauge Locomotives</b>          | <b>38 - 56</b> |
| - Butch                              | 38             |
| - Chub                               | 39             |
| - City of Truro                      | 40             |
| - Combpyne                           | 41             |
| - Dean Goods                         | 42             |
| - Dholphur                           | 43             |
| - Firefly                            | 44             |
| - GWR4700                            | 45             |
| - King John                          | 46             |
| - Maid of Kent                       | 47             |
| - Mogul 4300                         | 48             |
| - Nine Elms                          | 49             |
| - Pansy                              | 50             |
| - Peggy                              | 51             |
| - Salisbury                          | 52             |
| - Simplex                            | 53             |
| - Springbok B1                       | 54             |
| - Tich                               | 55             |
| - Twin Sisters                       | 56             |
| <b>7 1/4" Gauge Locomotives</b>      | <b>57 - 58</b> |
| - GWR 1366                           | 57             |
| - Tich                               | 58             |
| <b>Kennions Vertical Boiler</b>      | <b>59</b>      |
| <b>Stationary Engines</b>            | <b>60 - 64</b> |
| - Tina - Horizontal Mil Engine       | 60             |
| - Rachel - Wall Mounted Engine       | 61             |
| - Roxanne                            | 62             |
| - Suzanne                            | 63             |
| - Lara                               | 64             |
| <b>Drill and Pumps</b>               | <b>65 - 66</b> |
| - Sensitive Drill                    | 65             |
| - Weir Pump (Single)                 | 66             |
| - Weir Pump (Duplex)                 | 66             |
| <b>Additional</b>                    | <b>67</b>      |
| - 3 1/2" Service Truck               | 66             |
| - Bogie Casting`s                    | 67             |
| - Cast Wheel for 5" Passenger Trucks | 67             |
| - Tee & Elbow Castings               | 67             |

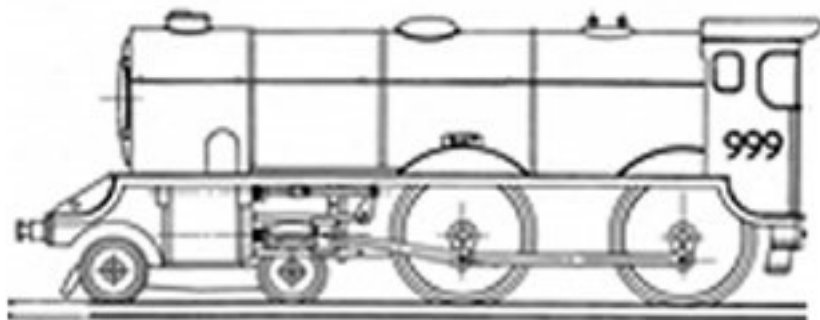
**'O' Gauge****BAT**

0 Gauge 4-4-0 Southern Tender  
Locomotive by L.S.B.C.

**Specification**

Overall Length (inc. Tender):  
Width: 2 1/2"  
Boiler Diameter: 1 3/4"  
Cylinder Bore: 3/8"  
Stroke: 5/8"  
Wheel Outside Diameter: 1 15/16"



|                                  |       |
|----------------------------------|-------|
| Full Drawing Set - 5 Sheets (A1) | 15126 |
|----------------------------------|-------|

| Item / Product / Casting   | SKU   |
|----------------------------|-------|
| Driving Wheel - CI (4 Req) | 52829 |
| Bogie Wheel - CI (4 Req)   | 56841 |
| Cylinder (2 Req)           | A163R |
| Steam Chest (2 Req)        | EK80  |
| Rear Cover (2 Req)         | 52812 |

| Item / Product / Casting       | SKU    |
|--------------------------------|--------|
| Eccentric Strap Pair           | 24     |
| Tender Wheel (6 Req)           | 52828  |
| Laser Cut Main Frame (2 Req)   | GLR033 |
| Laser Cut Tender Frame (2 Req) | GLR034 |

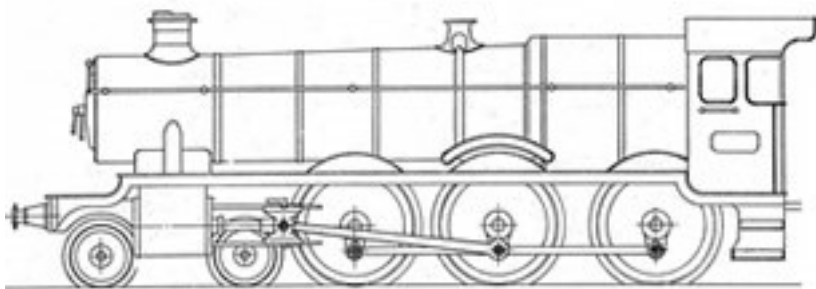
**'O' Gauge****Hertford Hall**

0 Gauge 4-6-0 GWR Tender Locomotive  
by Keith Wilson

**Specification**

Overall Length (inc. Tender): 17"  
Width: 2 3/8"  
Boiler Diameter (Tapers to): 1 1/2"  
Cylinder Bore: 3/8"  
Stroke: 5/8"  
Wheel Outside Diameter: 1 3/4"



|                                  |       |
|----------------------------------|-------|
| Full Drawing Set - 5 Sheets (A1) | 15125 |
|----------------------------------|-------|

| Item / Product / Casting   | SKU   |
|----------------------------|-------|
| Driving Wheel - CI (6 Req) | 52832 |
| Cylinder (2 Req)           | A163R |
| Steam Chest (2 Req)        | EK80  |
| Rear Cover (2 Req)         | 52812 |
| Eccentric Strap Pair       | 24    |

| Item / Product / Casting       | SKU    |
|--------------------------------|--------|
| Tender Wheel - CI (6 Req)      | 24     |
| Bogie Wheel - CI (4 Req)       | 56841  |
| Laser Cut Main Frame (2 Req)   | GLR035 |
| Laser Cut Tender Frame (2 Req) | GLR036 |

## Josie

## 'O' Gauge

0 Gauge 4-6-4 New York Hudson Type  
Tender Locomotive by L.S.B.C.

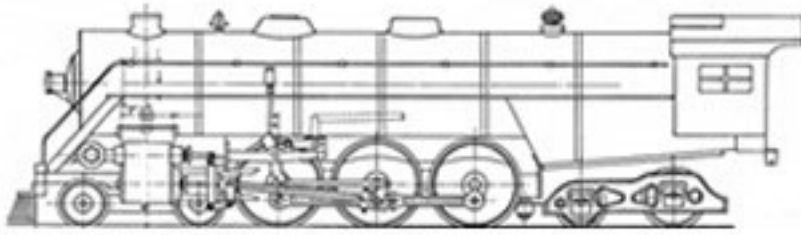

### Specification

Overall Length (inc. Tender):  
Width: 2 3/4"  
Boiler Diameter: 2"  
Cylinder Bore: 7/16"  
Stroke: 5/8"  
Wheel Outside Diameter: 1 25/32"



|                                  |       |
|----------------------------------|-------|
| Full Drawing Set - 5 Sheets (A1) | 15123 |
|----------------------------------|-------|

| Item / Product / Casting   | SKU   |
|----------------------------|-------|
| Driving Wheel - CI (6 Req) | 52825 |
| Cylinder (2 Req)           | A163R |
| Rear Cover (2 Req)         | 52812 |
| Eccentric Strap Pair       | 24    |
| Steam Chest (2 Req)        | EK80  |

| Item / Product / Casting     | SKU    |
|------------------------------|--------|
| Laser Cut Main Frame (2 Req) | GLR060 |

## Princess Coronation

## 'O' Gauge

0 Gauge 4-6-2 LMS Pacific Tender  
Locomotive

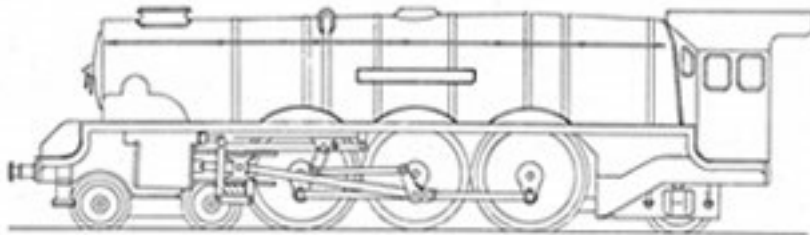

### Specification

Overall Length (inc. Tender):  
Width: 2 1/8"  
Boiler Diameter: 1 13/16"  
Cylinder Bore: 3/8"  
Stroke: 11/16"  
Wheel Outside Diameter: 2"



|                                 |       |
|---------------------------------|-------|
| Full Drawing Set - 5 Sheets (-) | 15127 |
|---------------------------------|-------|

| Item / Product / Casting             | SKU   |
|--------------------------------------|-------|
| Driving Wheel - CI (6 Req)           | 52825 |
| Bogie Wheel - CI (4 Req)             | 56841 |
| Trailing / Tender Wheel - CI (8 Req) | 56843 |
| Cylinder (2 Req)                     | A163R |
| Steam Chest (2 Req)                  | EK80  |

| Item / Product / Casting       | SKU    |
|--------------------------------|--------|
| Rear Cover (2 Req)             | 52812  |
| Eccentric Strap Pair           | 24     |
| Laser Cut Main Frame (2 Req)   | GLR030 |
| Laser Cut Tender Frame (2 Req) | GLR031 |
| Etched Plates (Black)          | 8004   |

**'O' Gauge****Royal Scot**

0 Gauge 4-6-0 LMS Tender Locomotive  
by Martin Evans

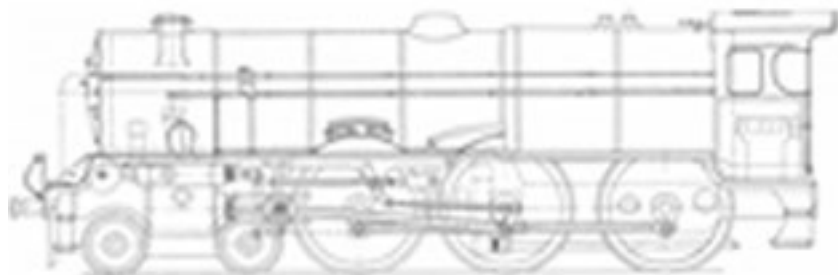

Specification

Overall Length (inc. Tender):  
Width: 2 9/16"  
Boiler Diameter: 1 5/8"  
Cylinder Bore: 5/16"  
Stroke: 9/16"  
Wheel Outside Diameter: 1 15/16"



|                                  |       |
|----------------------------------|-------|
| Full Drawing Set - 4 Sheets (A1) | 15124 |
|----------------------------------|-------|

|                    |       |
|--------------------|-------|
| Construction Notes | 15130 |
|--------------------|-------|

| Item / Product / Casting   | SKU   |
|----------------------------|-------|
| Driving Wheel - CI (6 Req) | 52829 |
| Bogie Wheel - CI (4 Req)   | 56841 |
| Tender Wheel - CI (6 Req)  | 52828 |
| Cylinder (2 Req)           | A163R |
| Steam Chest (2 Req)        | EK80  |

| Item / Product / Casting     | SKU    |
|------------------------------|--------|
| Rear Cover (2 Req)           | 52812  |
| Eccentric Strap Pair         | 24     |
| Laser Cut Main Frame (2 Req) | GLR032 |

**'O' Gauge****Sir Morris De Cowley**

0 Gauge 4-6-2 LNER Pacific Tender  
Locomotive by L.S.B.C.

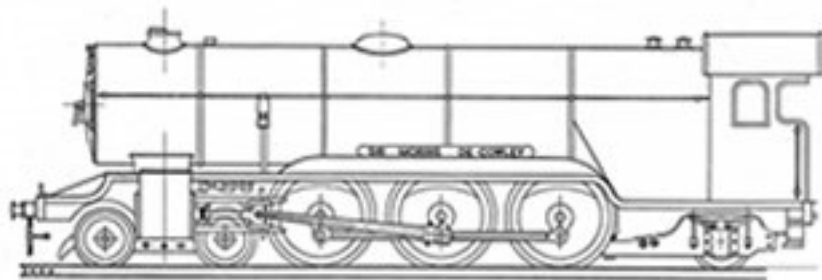

Specification

Overall Length (inc. Tender):  
Width: 2 1/2"  
Boiler Diameter: 2"  
Cylinder Bore: 3/8"  
Stroke: 5/8"  
Wheel Outside Diameter: 1 7/8"



|                                  |       |
|----------------------------------|-------|
| Full Drawing Set - 5 Sheets (A1) | 15128 |
|----------------------------------|-------|

| Item / Product / Casting             | SKU   |
|--------------------------------------|-------|
| Driving Wheel - CI (6 Req)           | 52841 |
| Bogie / Trailing Wheel - CI (6 Req)  | 56842 |
| Trailing / Tender Wheel - CI (6 Req) | 56843 |
| Cylinder (2 Req)                     | A163R |
| Steam Chest (2 Req)                  | EK80  |

| Item / Product / Casting       | SKU    |
|--------------------------------|--------|
| Rear Cover (2 Req)             | 52812  |
| Eccentric Strap Pair           | 24     |
| Laser Cut Main Frame (2 Req)   | GLR028 |
| Laser Cut Tender Frame (2 Req) | GLR029 |
| Etched Plates (Blue / Grey)    | LP16   |

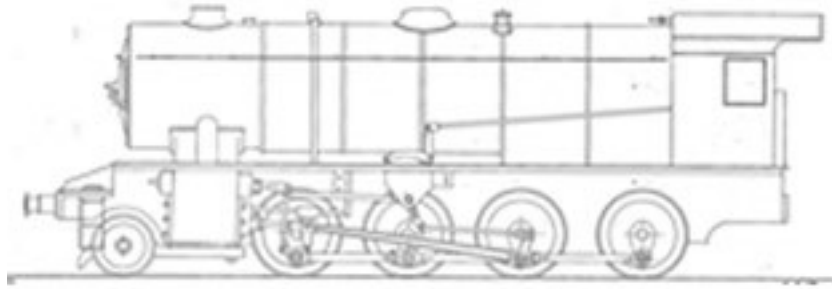

2 1/2" Gauge 2-8-0 Tender Locomotive  
by L.B.S.C.

### Specification

Overall Length (inc. Tender): 35"  
 Width: 4 7/8"  
 Boiler Diameter: 3 1/2"  
 Cylinder Bore: 1 1/4"  
 Stroke: 1 1/4"  
 Wheel Outside Diameter: 2 7/16"

Based on War Department Locomotive



|                                  |       |
|----------------------------------|-------|
| 8 x Sheet Full Drawing Set (A1M) | 15061 |
|----------------------------------|-------|

| Item / Product / Casting                       | SKU          |
|------------------------------------------------|--------------|
| Horn Block Pair (4 Req)                        | 25H          |
| Main Axle Box Strip (2 Req)                    | CB1          |
| Driving Wheel (8 Req)                          | AA225        |
| Pony Wheel (2 Req)                             | AA           |
| Pony Axle Box Strip                            | CBBB1        |
| Pony Bolster                                   | 5AA          |
| Pump Stay                                      | AA6          |
| Axle Pump Body                                 | 120          |
| Eccentric Strap (2 Req)                        | 283L         |
| Cylinder (2 Req)                               | 2XPC         |
| Steam Chest (2 Req)                            | 2DYS         |
| Rear Cover (2 Req)                             | 2ARC         |
| Front Cover (2 Req)                            | 178          |
| Piston Blank (2 Req)                           | 218GM        |
| <i>Piston Blank - CI (Alternative - 2 Req)</i> | <i>218CI</i> |
| Valve Pair                                     | 3TV          |

| Item / Product / Casting          | SKU   |
|-----------------------------------|-------|
| Smoke Box Door                    | CAH1  |
| Smoke Box Door Ring               | CAT2  |
| Saddle Bracket (2 Req)            | 165   |
| Chimney                           | 355   |
| Dome                              | 2FAD  |
| Superheater End Blocks            | 70    |
| Tender Wheel (8 Req)              | CBB   |
| Tender Cast Spring / Horn (8 Req) | A165  |
| Tender Axle Box Strip (3 Req)     | A164R |
| Hand Pump                         | 133   |

| Additional Product Requirements |         |
|---------------------------------|---------|
| Laser Cut Main Frame (2 Req)    | GLR039  |
| Laser Cut Tender Frame (2 Req)  | KEN201A |
| Name Plates (Blue / Grey)       | LP18    |
| Main Axle Box Spring (16 Req)   |         |

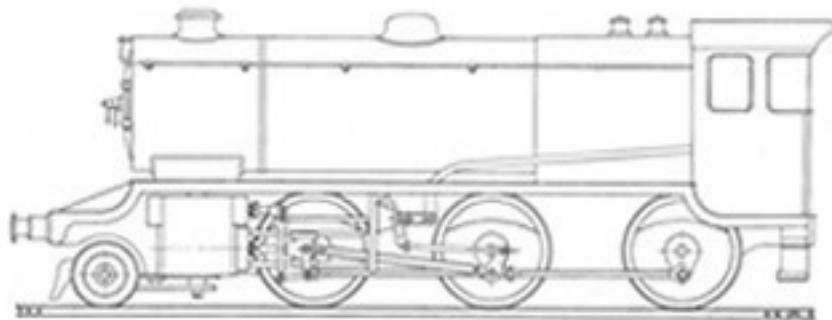

2 1/2" Gauge 2-6-0 LNER Tender  
Locomotive by L.B.S.C.

Specification

Overall Length (inc. Tender): 31 1/2"  
 Width: 4 3/4"  
 Boiler Diameter: 3 1/4"  
 Cylinder Bore: 13/16"  
 Stroke: 1 1/8"  
 Wheel Outside Diameter: 2 15/16"



|                                 |       |
|---------------------------------|-------|
| 7 x Sheet Full Drawing Set (A1) | 15062 |
|---------------------------------|-------|

| Item / Product / Casting                       | SKU          |
|------------------------------------------------|--------------|
| Horn Block Pair (3 Req)                        | 25H          |
| Main Axle Box Strip                            | CB1          |
| Wheel (6 Req)                                  | 2DYDW        |
| Brake Shoe Ring                                | DC1          |
| Pony Wheel (2 Req)                             | 230          |
| Pony Truck                                     | 2DYPT        |
| Pony Bolster                                   | 2DYPB        |
| Pump Stay                                      | AA6          |
| Axle Pump Body                                 | 120          |
| Pump Eccentric Strap                           | 283L         |
| Cylinder (2 Req)                               | 2DYC         |
| Steam Chest (2 Req)                            | 2DYS         |
| Rear Cover (2 Req)                             | 193          |
| Front Cover (2 Req)                            | 178          |
| Motion Bracket L/H                             | EK88         |
| Motion Bracket R/H                             | EK89         |
| Piston Blank (2 Req)                           | 218GM        |
| <i>Piston Blank - CI (Alternative - 2 Req)</i> | <i>218CI</i> |

| Item / Product / Casting          | SKU   |
|-----------------------------------|-------|
| Valve Pair                        | 3TV   |
| Smoke Box Door                    | CAH1  |
| Smoke Box Door Ring               | CAS1  |
| Saddle Bracket (2 Req)            | 165   |
| Chimney                           | 355   |
| Dome                              | 361   |
| Superheater End Blocks            | 70    |
| Tender Wheel                      | 233   |
| Tender Cast Spring / Horn (6 Req) | A165  |
| Tender Axle Box Strip (2 Req)     | A164R |
| Hand Pump                         | 132   |

| Additional Product Requirements |            |
|---------------------------------|------------|
| Laser Cut Main Frame (2 Req)    | GLR026     |
| Laser Cut Tender Frame (2 Req)  | GLR027     |
| Name Plates (Red)               | DyakPlates |
| Main Axle Box Spring (12 Req)   |            |
| Tender Axle Box Spring (6 Req)  |            |

2 1/2" Gauge 4-6-2 Freelance Pacific  
Tender Locomotive by L.B.S.C.

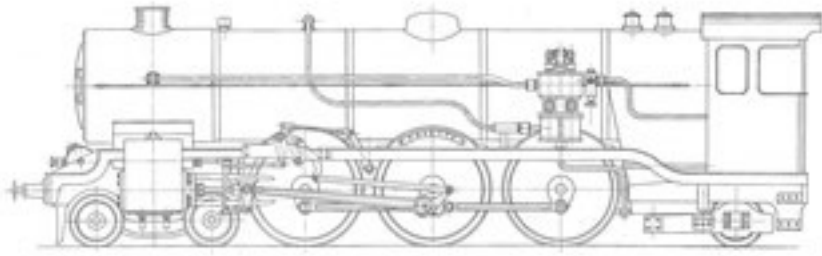

### Specification

Overall Length (inc. Tender): 35 1/2"  
Width: 4 3/4"  
Boiler Diameter: 3 1/2"  
Cylinder Bore: 13/16"  
Stroke: 1 1/8"  
Wheel Outside Diameter: 3 3/4"

Anglo American locomotive



|                                  |       |
|----------------------------------|-------|
| 9 x Sheet Full Drawing Set (A1M) | 15065 |
|----------------------------------|-------|

| Item / Product / Casting            | SKU   |
|-------------------------------------|-------|
| Horn Block Pair (3 Req)             | 25H   |
| Main Axle Box Strip                 | CB1   |
| Driving Wheel - CI (2 Reg)          | 25PR  |
| Coupled Wheel - CI (4 Reg)          | 225   |
| Brake Shoe Ring - CI                | DE1   |
| Bogie / Trailing Wheel - CI (6 Req) | 230   |
| Bogie Axle Box Strip                | CBBB1 |
| Bogie Equaliser                     | 160   |
| Bogie Pin Bolster                   | 164L  |
| Bogie Bolster                       | 164R  |
| Pump Stay                           | AA6   |
| Axle Pump Body                      | 120   |
| Pump Eccentric Strap                | 283L  |
| Cylinder (2 Req)                    | 2FAC  |
| Steam Chest (2 Req)                 | 2FASC |
| Rear Cover (2 Req)                  | 193   |
| Front Cover (2 Req)                 | 178   |
| Guide Bracket (2 Req)               | 2FAGB |
| Valve Pair                          | 2FAV  |

| Item / Product / Casting                       | SKU          |
|------------------------------------------------|--------------|
| Piston Blank (2 Req)                           | 218GM        |
| <i>Piston Blank - CI (Alternative - 2 Req)</i> | <i>218CI</i> |
| Smoke Box Door                                 | CAH1         |
| Smoke Box Door Ring                            | CAT1         |
| Saddle Bracket (2 Req)                         | 165          |
| Chimney                                        | CY4          |
| Dome                                           | 2FAD         |
| Jackson Bettendorf Frame (4 Req)               | 124LL        |
| Jackson Bettendorf Beam (2 Req)                |              |
| Superheater End Blocks                         |              |
| Tender Wheel (6 Req)                           | AA           |
| Hand Pump                                      | 132          |

| Additional Product Requirements |         |
|---------------------------------|---------|
| Laser Cut Bogie Frame (2 Req)   | KEN203B |
| Laser Cut Main Frame (2 Req)    | GLR203A |
| Name Plates (Blue)              | LP26    |
| Main Axle Box Spring (12 Req)   |         |
| Tender Axle Box Spring (8 Req)  |         |



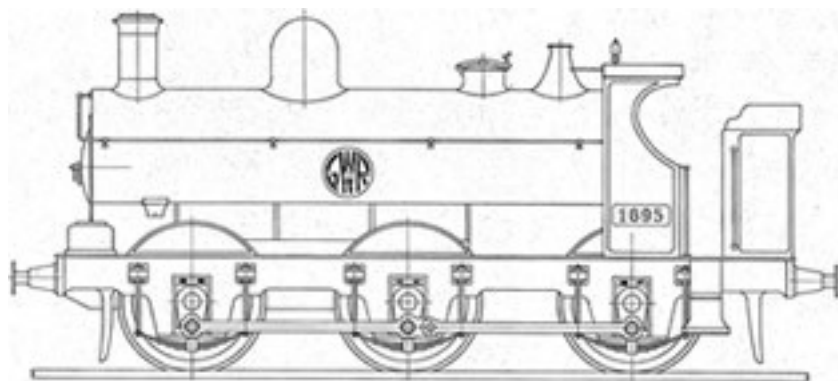

2 1/2" Gauge 0-6-0 Class 1600 Tank Locomotive by L.B.S.C.

Specification

Overall Length: 16"  
 Width: 4 3/4"  
 Boiler Diameter: 2 3/4"  
 Cylinder Bore: 5/8"  
 Stroke: 1"  
 Wheel Outside Diameter: 2 15/16"



This powerful and reliable locomotive of exhibition standard; a good looking engine that works really well. Every external rivet location was measured from enlarged photographs of the full size locomotive. The only alterations have been for ease of construction and reliability of performance.

|                                 |       |
|---------------------------------|-------|
| 4 x Sheet Full Drawing Set (A1) | 15153 |
|---------------------------------|-------|

|                    |       |
|--------------------|-------|
| Construction Notes | 15154 |
|--------------------|-------|

| Item / Product / Casting                       | SKU          |
|------------------------------------------------|--------------|
| Horn Block Pair (3 Req)                        | 25H          |
| Main Axle Box Strip                            | CB1          |
| Driving Wheel - CI (6 Req)                     | 1695DW       |
| Eccentric Strap (5 Req)                        | 283L         |
| Cylinder Block (1 Req)                         | 25CYL        |
| Steam Chest (1 Req)                            | 25SC         |
| Front End Cover (2 Req)                        | 178          |
| Rear End Cover (2 Req)                         | 193          |
| Piston Blank (2 Req)                           | 218GM        |
| <i>Piston Blank - CI (Alternative - 2 Req)</i> | <i>218CI</i> |

| Item / Product / Casting | SKU   |
|--------------------------|-------|
| Pump Stay                | AA6   |
| Pump Body                | 120   |
| Chimney                  | 356   |
| Safety Valve Cover       | 2PGSV |
| Saddle Bracket (2 Req)   | 165   |

| Additional Product Requirements |         |
|---------------------------------|---------|
| Laser Cut Main Frame (2 Req)    | GLR204  |
| Laser Cut Inside Frame (2 Req)  | GLR204A |

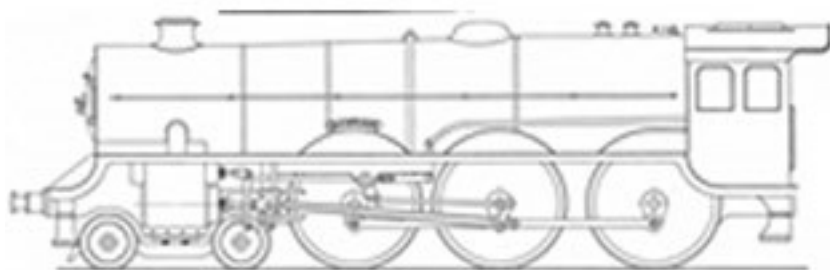

2 1/2" Gauge 4-6-0 LMS Tender  
Locomotive by L.B.S.C.

### Specification

Overall Length (inc. Tender): 35"  
Width: 4 7/8"  
Boiler Diameter (Tapers to): 3"  
Cylinder Bore: 1 1/16"  
Stroke: 1 1/8"  
Wheel Outside Diameter: 3 13/16"



|                                 |       |
|---------------------------------|-------|
| 7 x Sheet Full Drawing Set (A1) | 15064 |
|---------------------------------|-------|

| Item / Product / Casting                       | SKU          |
|------------------------------------------------|--------------|
| Horn Block Pair (3 Req)                        | 25H          |
| Main Axle Box Strip (2 Req)                    | CB1          |
| Driving Wheel (2 Req)                          | 25PR         |
| Coupled Wheel (4 Req)                          | 225          |
| Brake Shoe Ring                                | DE1          |
| Bogie Wheel - CI (4 Req)                       | 230          |
| Bogie Axle Box Strip                           | CBBB1        |
| Bogie Pin Bolster                              | 164L         |
| Bogie Bolster                                  | 164R         |
| Bogie Equaliser (2 Req)                        | 160          |
| Pump Stay                                      | AA6          |
| Axle Pump Body                                 | 120          |
| Eccentric Strap (2 Req)                        | 283L         |
| Outside Cylinder (2 Req)                       | 2XPC         |
| Outside Steam Chest (2 Req)                    | 2FASC        |
| Rear Cover (3 Req)                             | 178          |
| Front Cover 3 (Req)                            | 193          |
| Piston Blank (3 Req)                           | 218GM        |
| <i>Piston Blank - CI (Alternative - 3 Req)</i> | <i>218CI</i> |
| Inside Cylinder                                | 2XPIC        |
| Inside Steam Chest                             | EK43         |

| Item / Product / Casting          | SKU   |
|-----------------------------------|-------|
| Outside Motion Bracket (2 Req)    | 200MB |
| Exhaust Tee                       | 118   |
| Smoke Box Door                    | CAG1  |
| Smoke Box Door Ring               | CAR1  |
| Saddle Bracket (2 Req)            | 165   |
| Chimney                           | 355   |
| Dome                              | 2FAD  |
| Superheater End Blocks            |       |
| Tender Wheel - CI (6 Req)         | 233   |
| Tender Cast Spring / Horn (6 Req) | A165  |
| Tender Axle Box Strip (2 Req)     | A164R |
| Hand Pump                         | 132   |

| Additional Product Requirements    |         |
|------------------------------------|---------|
| Laser Cut Bogie Frame (2 Req)      | KEN205B |
| Laser Cut Main Frame (2 Req)       | GLR205A |
| Laser Cut Tender Frame (2 Req)     | GLR038  |
| Name Plates (Black / Blue / Green) | LP25    |
| Main Axle Box Spring (12 Req)      |         |
| Tender Axle Box Spring (6 Req)     |         |



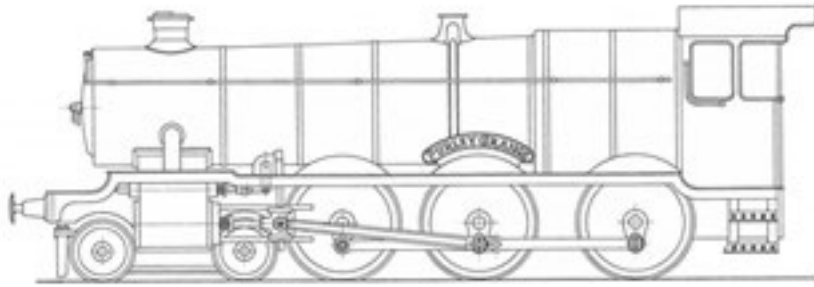

2 1/2" Gauge 4-6-0 GWR Tender  
Locomotive by L.B.S.C.

Specification

Overall Length (inc. Tender): 32 1/2"  
Width: 4 7/8"  
Boiler Diameter (Tapers to): 3"  
Cylinder Bore: 13/16"  
Stroke: 1 1/8"  
Wheel Outside Diameter: 3 1/6"



Anglo American Locomotive

|                                  |       |
|----------------------------------|-------|
| Full Drawing Set - 6 Sheets (A2) | 15060 |
|----------------------------------|-------|

| Item / Product / Casting                       | SKU          |
|------------------------------------------------|--------------|
| Horn Block Pair (3 Req)                        | 25H          |
| Main Axle Box Strip (2 Req)                    | CB1          |
| Driving Wheel - CI (6 Req)                     | CCC          |
| Brake Shoe Ring - CI                           | DC3          |
| Bogie Wheel (4 Req)                            | 230          |
| Bogie Axle Box Strip                           | CBBB1        |
| Bogie Pin Bolster                              | 164L         |
| Bogie Bolster                                  | 164R         |
| Bogie Equaliser (2 Req)                        | 160          |
| Pump Stay                                      | EK124        |
| Axle Pump Body                                 | 139R         |
| Eccentric Strap (6 Req)                        | 283L         |
| Cylinder (2 Req)                               | 2PCC         |
| Steam Chest (2 Req)                            | EK20         |
| Rear Cover (2 Req)                             | 193          |
| Front Cover (2 Req)                            | 178          |
| Piston Blank (2 Req)                           | 218GM        |
| <i>Piston Blank - CI (Alternative - 2 Req)</i> | <i>218CI</i> |
| Valve Pair                                     | 3TV          |

| Item / Product / Casting          | SKU   |
|-----------------------------------|-------|
| Motion Bracket LH                 | EK130 |
| Motion Bracket RH                 | EK131 |
| Smoke Box Door                    | CAG1  |
| Smoke Box Door Ring               | CAR1  |
| Saddle Bracket (2 Req)            | 165   |
| Chimney                           | 355   |
| Safety Valve Cover                | 2PGSV |
| Superheater End Blocks            | 70    |
| Tender Wheel - CI (6 Req)         | 233   |
| Tender Cast Spring / Horn (6 Req) | A165  |
| Tender Axle Box Pair (3 Req)      | 2PGX  |
| Hand Pump                         | 132   |

| Additional Product Requirements |        |
|---------------------------------|--------|
| Laser Cut Main Frame (2 Req)    | GLR041 |
| Laser Cut Tender Frame (2 Req)  | GLR037 |
| Main Axle Box Strip (12 Req)    |        |
| Tender Axle Box Strip (6 Req)   |        |



# S15 Maunsell

## 2 1/2" Gauge

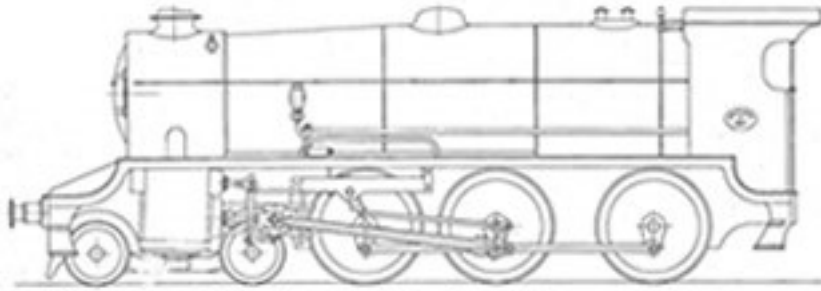

2 1/2" Gauge 4-6-0 Southern Tender  
Locomotive by L.S.B.C.

### Specification

Overall Length (inc. Tender): 35 1/4"  
Width: 4 7/8"  
Boiler Diameter (Tapers to): 3"  
Cylinder Bore: 13/16"  
Stroke: 1 1/8"  
Wheel Outside Diameter: 3 1/16"



|                                  |       |
|----------------------------------|-------|
| Full Drawing Set - 6 Sheets (A1) | 15151 |
|----------------------------------|-------|

|                    |       |
|--------------------|-------|
| Construction Notes | 15152 |
|--------------------|-------|

| Item / Product / Casting           | SKU   |
|------------------------------------|-------|
| Horn Block Pair (3 Req)            | 25H   |
| Main Axle Box Strip                | CB1   |
| Driving Wheel - CI (6 Req)         | S15DW |
| Bogie / Tender Wheel - CI (12 Req) | 230A  |
| Bogie Axle Box Strip               | CBBB1 |
| Bogie Equaliser (2 Req)            | 160   |
| Bogie Pin Bolster                  | 164L  |
| Bogie Bolster                      | 164R  |
| Pump Stay                          | AA6   |
| Axle Pump Body                     | 120   |
| Pump Eccentric Strap               | 283L  |
| Cylinder (2 Req)                   | 2XPC  |
| Steam Chest (2 Req)                | 2FASC |
| Rear Cover (2 Req)                 | 193   |
| Front Cover                        | 178   |
| Outside Motion Bracket             | 200MB |
| Motion Eccentric Strap             |       |

| Item / Product / Casting                       | SKU          |
|------------------------------------------------|--------------|
| Steam Tee Collector                            | 247          |
| Piston Blank (2 Req)                           | 218GM        |
| <i>Piston Blank - CI (Alternative - 2 Req)</i> | <i>218CI</i> |
| Valve Pair                                     | 5TV          |
| Smoke Box Door                                 | CAG1         |
| Saddle Bracket                                 | 165          |
| Chimney                                        | 355          |
| Dome                                           | 2FAD         |
| Tender Cast Spring / Horn (8 Req)              | A165         |
| Tender Axle Box Strip (3 Req)                  | A164R        |
| Hand Pump                                      | 132          |

| Additional Product Requirements      |         |
|--------------------------------------|---------|
| Laser Cut Bogie Frame (2 Req)        | GLR206C |
| Laser Cut Main Frame (2 Req)         | GLR206A |
| Laser Cut Tender Bogie Frame (4 Req) | GLR206B |

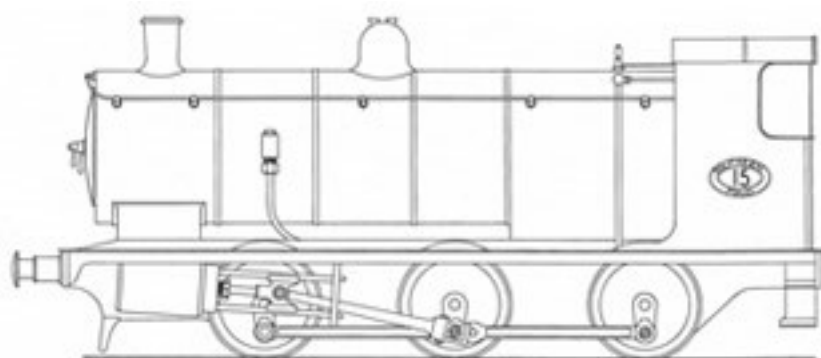

2 1/2" Gauge 0-6-0 Southern Tender Locomotive by L.B.S.C.

### Specification

Overall Length (inc. Tender): 28"  
 Width: 4 3/4"  
 Boiler Diameter: 1 3/4"  
 Cylinder Bore: 3/4"  
 Stroke: 1 1/8"  
 Wheel Outside Diameter: 2 7/16"



Southern Maid is a Simple Engine which is ideal for beginners

|                                   |       |
|-----------------------------------|-------|
| Full Drawing Set - 5 Sheets (A1L) | 15063 |
|-----------------------------------|-------|

| Item / Product / Casting                       | SKU          |
|------------------------------------------------|--------------|
| Horn Block Pair (3 Req)                        | 25H          |
| Main Axle Box Strip                            | CB1          |
| Driving Wheel - CI (6 Req)                     | AA225        |
| Brake Shoe Ring - CI                           | DB1          |
| Pump Stay                                      | AA6          |
| Pump Body                                      | 120          |
| Pump Eccentric Strap                           | 283L         |
| Cylinder (2 Req)                               | 2SMC         |
| Steam Chest (2 Req)                            | 2SMS         |
| Rear Cover (2 Req)                             | 193          |
| Front Cover (2 Req)                            | 178          |
| Motion Guide Bracket L/H                       | EK128        |
| Motion Guide Bracket R/H                       | EK129        |
| Piston Blank(2 Req)                            | 218GM        |
| <i>Piston Blank - CI (Alternative - 2 Req)</i> | <i>218CI</i> |
| Valve Pair                                     | 3TV          |
| Valve Eccentric Strap (2 Req)                  | 283S         |

| Item / Product / Casting          | SKU   |
|-----------------------------------|-------|
| Smoke Box Door                    | CAG1  |
| Smoke Box Door Ring               | CAS2  |
| Saddle Bracket (2 Req)            | 165   |
| Chimney                           | 356   |
| Dome                              | 557   |
| Superheater End Blocks            | 71    |
| Tender Wheel - CI (6 Req)         | 213   |
| Tender Cast Spring / Horn (6 Req) | A165  |
| Tender Axle Box Strip (2 Req)     | A164R |
| Hand Pump                         | 132   |

| Additional Product Requirements |        |
|---------------------------------|--------|
| Laser Cut Main Frame (2 Req)    | GLR024 |
| Laser Cut Tender Frame (2 Req)  | GLR025 |
| Main Axle Box Spring (12 Req)   |        |
| Tender Axle Box Spring (6 Req)  |        |



# Bantam Cock

# 3 1/2" Gauge

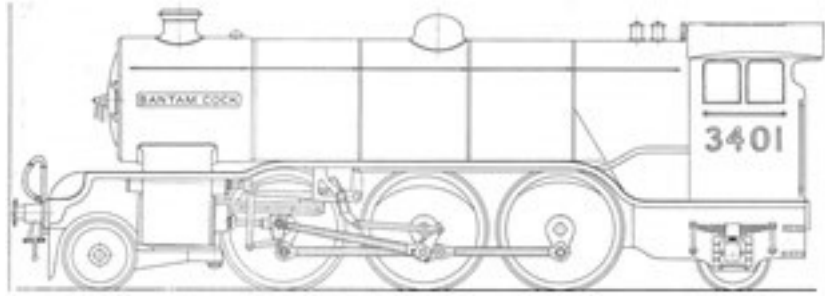

3 1/2" Gauge 2-6-2 Class V4 Tender  
Locomotive by L.B.S.C.

### Specification

Overall Length (inc. Tender): 45"  
Width: 7 1/8"  
Boiler Diameter: 4 1/4"  
Cylinder Bore: 1 1/8"  
Stroke: 1 5/8"  
Wheel Outside Diameter: 4 1/4"



|                                  |       |
|----------------------------------|-------|
| Full Drawing Set - 8 Sheets (A1) | 15055 |
|----------------------------------|-------|

|                    |  |
|--------------------|--|
| Construction Notes |  |
|--------------------|--|

| Item / Product / Casting                       | SKU          |
|------------------------------------------------|--------------|
| Horn Block Pair (3 Req)                        | CD1          |
| Axle Box Strip                                 | CE1          |
| Driving Wheel - CI (2 Req)                     | 3DORDW       |
| Coupled Wheel - CI (4 Req)                     | 3DORCW       |
| Brake Shoe Ring - CI                           | DG1          |
| Pump Stay                                      | BC100        |
| Pump Body                                      | 166          |
| Eccentric Strap (2 Req)                        | 286          |
| Cylinder (2 Req)                               | BCCYL        |
| Steam Chest (2 Req)                            | BCSC         |
| Valve Pair                                     | BCV          |
| Piston Blank (2 Req)                           | 219GM        |
| <i>Piston Blank - CI (Alternative - 2 Req)</i> | <i>219CI</i> |
| Rear Cover (2 Req)                             | 198          |
| Front Cover (2 Req)                            | 180F         |
| Guide Bar Bracket L/H                          | BCMBLH       |
| Guide Bar Bracket R/H                          | BCMBRH       |
| Trailing / Pony Wheel - CI (4 Req)             | BCP&T        |
| Pony Axle Box Strip                            | CF2          |

| Item / Product / Casting       | SKU      |
|--------------------------------|----------|
| Trailing Spring & Horn (2 Req) | BCTS     |
| Trailing Axle Box Pair         | 3HL14    |
| Trailing Bracket               | EK61     |
| Smoke Box Door                 | CAK1     |
| Smoke Box Door Ring            | BCSBR    |
| Saddle                         | BCSADDLE |
| Chimney                        | BCCH     |
| Tender Horn (6 Req)            | 340      |
| Tender Spring (6 Req)          | BCTDS    |
| Tender Axle Box (6 Req)        | 257      |
| Tender Wheel - CI (6 Req)      | 242BC    |
| Tender Hand Pump               | 134      |

| Additional Product Requirements         |        |
|-----------------------------------------|--------|
| Laser Cut Main Frame (2 Req)            | GLR016 |
| Trailing Bracket Steel - Precut (2 Req) | GLR017 |
| Laser Cut Tender Frame (2 Req)          | GLR018 |
| Main Axle Box Spring (12 Req)           |        |

3 1/2" Gauge 4-6-2 Tender Locomotive  
by L.B.S.C.

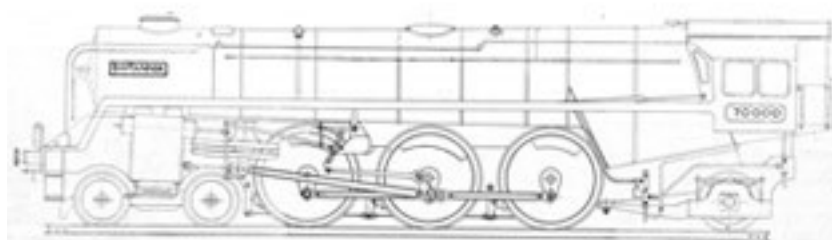

### Specification

Overall Length (inc. Tender): 52"  
 Width: 5 7/8"  
 Boiler Diameter (Tapers to): 4 1/2"  
 Cylinder Bore: 1 1/4"  
 Stroke: 1 3/4"  
 Wheel Outside Diameter: 4 7/8"



Full Drawing Set - 16 Sheets (A1/L) 15095

| Item / Product / Casting             | SKU   |
|--------------------------------------|-------|
| Axle Box Strip                       | CG3   |
| Driving Wheel - CI (2 Req)           | 3BDW  |
| Coupled Wheel - CI (4 Req)           | 3BCW  |
| Brake Shoe Ring - CI                 | DJ1   |
| Bogie Axle Box Strip                 | CG1   |
| Bogie Equaliser (2 Req)              | 254   |
| Bogie Bolster                        | 110R  |
| King Pin Stay                        | 110L  |
| Bogie Wheel (4 Req)                  | 262   |
| Trailing Truck                       | C11   |
| Trailing / Tender Spring (8 Req)     | 344   |
| Trailing / Tender Wheel - CI (8 Req) | 3BLTW |
| Intermediate Stay                    | 111R  |
| Pump Stay                            | 111L  |
| Pump Body                            | 163   |
| Cylinder (2 Req)                     | 3BC   |
| Piston Valve Linder (2 Req)          | 3BCL  |
| Rear Cylinder Cover (2 Req)          | 34    |
| Front Cylinder Cover (2 Req)         | 5PFC  |
| Eccentric Strap (2 Req)              | 286   |

| Item / Product / Casting    | SKU   |
|-----------------------------|-------|
| Guide Bar Bracket L/H       | 112L  |
| Guide Bar Bracket R/H       | 112R  |
| Motion Bracket              | 113L  |
| Motion Bracket              | 113R  |
| Motion Bracket              | 116L  |
| Motion Bracket              | 116R  |
| Smoke Box Door              | CAK2  |
| Smoke Box Door Ring         | CAV1  |
| Saddle                      | 3B    |
| Dome                        | 114L  |
| Chimney                     | 114R  |
| Superheater End Blocks      | 70    |
| Tender Horn Pair (3 Req)    | 327   |
| Tender Spring (6 Req)       | BRITM |
| Tender Brake Shoe Ring - CI | DB1   |
| Tender Hand Pump            | 134   |

| Additional Product Requirements |         |
|---------------------------------|---------|
| Laser Cut Bogie Frame (2 Req)   | GLR301C |
| Laser Cut Main Frame (2 Req)    | GLR301A |
| Laser Cut Tender Frame (2 Req)  | GLR301B |



# Canterbury Lamb

## 3 1/2" Gauge

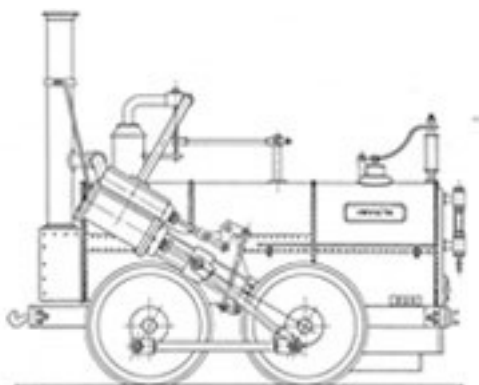

3 1/2" Gauge 0-4-0 Tender Locomotive  
by L.B.S.C.

### Specification

Overall Length (inc. Tender): 18"  
Width: 4 1/2"  
Boiler Diameter: 2 7/8"  
Cylinder Bore: 1 1/16"  
Stroke: 1 1/4"  
Wheel Outside Diameter: 3 1/4"

One of the most interesting models that we have to offer. A copy of the original 'Invicta' is still on show at Canterbury



|                                     |       |
|-------------------------------------|-------|
| Full Drawing Set - 9 Sheets (A1L/M) | 15056 |
|-------------------------------------|-------|

|                    |  |
|--------------------|--|
| Construction Notes |  |
|--------------------|--|

| Item / Product / Casting          | SKU  |
|-----------------------------------|------|
| Main Horn Pair (2 Req)            | 25H  |
| Main Axle Box Strip               | CB3  |
| Period Driving Wheel - CI (2 Req) | CBV  |
| Period Wheel Coupled - CI (2 Req) | CBF  |
| Pump Stay                         | 313  |
| Brake Shoe Ring                   | DD1  |
| Axle Pump Body                    | 163  |
| Eccentric Strap (3 Req)           | 284  |
| Cylinder (2 Req)                  | 3CLC |
| Steam Chest (2 Req)               | 3CLS |
| Rear Cover (2 Req)                | 193  |
| Front Cover (2 Req)               | 178  |
| Valve Pair (1 Req)                | 3TV  |
| Hand Pump                         | 133  |

| Item / Product / Casting                       | SKU          |
|------------------------------------------------|--------------|
| Smoke Box Front                                | 188          |
| Tender Wheel - CI (4 Req)                      | CCR          |
| Tender Axle Box Strip                          | CF2          |
| Piston Blank (2 Req)                           | 218GM        |
| <i>Piston Blank - CI (Alternative - 2 Req)</i> | <i>218CI</i> |

| Additional Product Requirements    |        |
|------------------------------------|--------|
| Laser Cut Locomotive Frame (2 Reg) | GLR004 |
| Laser Cut Tender Frame (2 Req)     | GLR005 |
| O Ring Set                         |        |
| Main Axle Spring (8 Req)           |        |
| Tender Axle Spring (4 Req)         |        |
| Name Plate                         | CLNPGM |



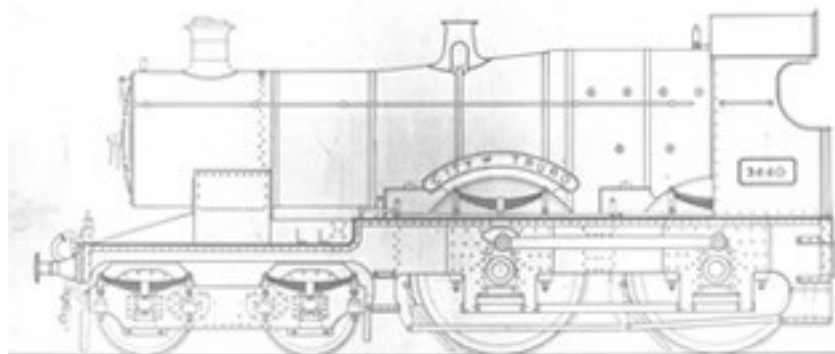

3 1/2" Gauge 4-4-0 GWR Tender  
Locomotive by C Kennion & K Wilson

## Specification

Overall Length (inc. Tender): 42"  
Width: 5 9/16"  
Boiler Diameter (Tapers to): 3 7/8"  
Cylinder Bore: 1 1/8"  
Stroke: 1 1/2"  
Wheel Outside Diameter: 5 17/64"



|                                  |       |
|----------------------------------|-------|
| Full Drawing Set - 14 Sheets (-) | 15162 |
|----------------------------------|-------|

| Item / Product / Casting                       | SKU          |
|------------------------------------------------|--------------|
| Horn Block Cheek (4 Req)                       | 306          |
| Main Axle Box Strip                            | 307          |
| Driving / Coupled Wheel - CI (4 Req)           | 3CTDW        |
| Brake Shoe Ring - CI                           | D11B         |
| Eccentric Strap (4 Req)                        | 286          |
| Draw Bar                                       | 308          |
| Dean Bogie Centre                              | 315          |
| Bogie Wheel - CI (4 Req)                       | HL7          |
| Bogie Axle Boxes - 1 Pair (2 Req)              | 309          |
| Bogie Pivot Stay                               | 310          |
| Bogie Centre Block                             | 311          |
| Cylinder Block                                 | 3COTC        |
| Steam Chest                                    | 3CTS         |
| Front Cover (2 Req)                            | RRFC         |
| Rear Cover (2 Req)                             | 3COTRC       |
| Piston Blank (2 Req)                           | 219GM        |
| <i>Piston Blank - CI (Alternative - 2 Req)</i> | <i>219CI</i> |
| Motion Plate                                   | 312          |
| Smoke Box Door Ring                            | CAK2         |
| Smoke Box Door                                 | CAV2         |

| Item / Product / Casting           | SKU   |
|------------------------------------|-------|
| Chimney                            | 319   |
| Safety Valve Cover                 | 320   |
| Superheater End Blocks             | 70    |
| Tender Horn                        | 317   |
| Tender Axle Boxes - 1 Pair (3 Req) | 318   |
| Tender Wheel - CI (6 Req)          | 3BTEN |
| Tender Brake Shoe Ring - CI        | DD1   |
| Tender Hand Pump                   | 134   |
| Buffer (4 Req)                     | GWRB1 |

| Additional Product Requirements    |         |
|------------------------------------|---------|
| Name Plate                         | 3COTNP  |
| Number Plate                       | 3COTNO  |
| Etched Name & Number Plate Set     | 8003    |
| Laser Cut Bogie Frame (2 Req)      | GLR302C |
| Laser Cut Main Inner Frame (2 Req) | GLR302D |
| Laser Cut Main Outer Frame (2 Req) | GLR302A |
| Laser Cut Tender Frame (2 Req)     | GLR302B |
| O Ring Set                         |         |



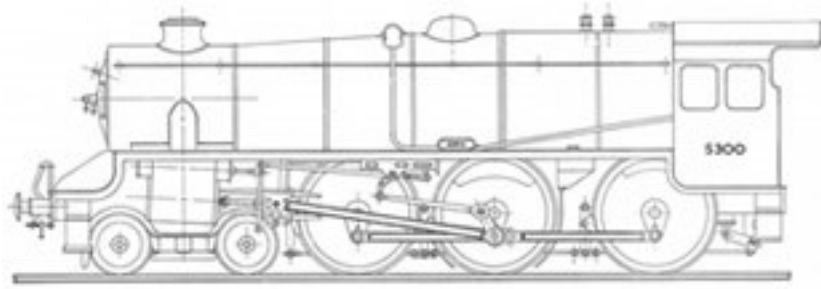

3 1/2" Gauge 4-6-0 LMS Black Tender  
Locomotive by L.B.S.C.

### Specification

Overall Length (inc. Tender): 48 1/4"  
Width: 5 7/8"  
Boiler Diameter (Tapers to): 4"  
Cylinder Bore: 1 5/32"  
Stroke: 1 3/4"  
Wheel Outside Diameter: 4 3/4"



|                                     |       |
|-------------------------------------|-------|
| Full Drawing Set - 12 Sheets (A1/M) | 15054 |
|-------------------------------------|-------|

|                    |  |
|--------------------|--|
| Construction Notes |  |
|--------------------|--|

| Item / Product / Casting                       | SKU          |
|------------------------------------------------|--------------|
| Horn Block Pair (3 Req)                        | CD1          |
| Axle Box Strip                                 | CE1          |
| Pump Stay                                      | 332          |
| Axle Pump                                      | 166          |
| Axle Pump Tee Body                             | 164          |
| Driving Wheel - CI (2 Req)                     | 3DORDW       |
| Coupled Wheel - CI (4 Req)                     | 3DORCW       |
| Brake Shoe Ring - CI                           | DG1          |
| Pump Eccentric Strap                           | 286          |
| Lubricator Eccentric Strap                     | 285L         |
| Cylinder (2 Req)                               | 3DC          |
| Front Cover (2 Req)                            | 197          |
| Rear Cover (2 Req)                             | 196          |
| Steam Chest Liner (2 Req)                      | 3DL          |
| Piston Blank (2 Req)                           | 219GM        |
| <i>Piston Blank - CI (Alternative - 2 Req)</i> | <i>219CI</i> |
| Bogie Axle Box Strip                           | CF2          |
| Bogie Bolster                                  | 334          |
| Bogie Pin Bolster                              | 336          |
| Bogie Wheel - CI (4 Req)                       | 3DBW         |
| Bogie Equaliser (2 Req)                        | 254          |

| Item / Product / Casting    | SKU   |
|-----------------------------|-------|
| Guide Bar Bracket Pair      | 255   |
| Smoke Box Door              | CAK2  |
| Smoke Box Door Ring         | CAV2  |
| Saddle                      | 305   |
| Dome                        | 3DD   |
| Chimney                     | 358   |
| Crosshead (2 Req)           | BD1   |
| Superheater End Blocks      | 70    |
| Doris Regulator Stand       | 3DREG |
| Tender Horn (6 Req)         | 324   |
| Tender Spring (6 Req)       | 344   |
| Tender Axle Box (6 Req)     | 257   |
| Tender Wheel - CI (6 Req)   | X206  |
| Tender Brake Shoe Ring - CI | DC4   |
| Tender Hand Pump            | 134   |

| Additional Product Requirements |         |
|---------------------------------|---------|
| Laser Cut Bogie Frame (2 Req)   | KEN310A |
| Laser Cut Main Frame (2 Req)    | KEN310B |
| Laser Cut Tender Frame (2 Req)  | KEN310C |



3 1/2" Gauge 4-6-2 L.N.E.R. Tender  
Locomotive by L.B.S.C.

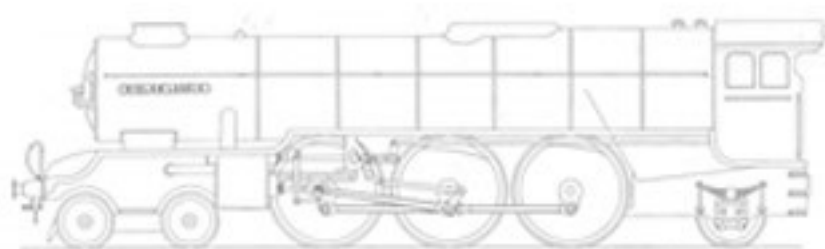

### Specification

Overall Length (inc. Tender): 55 1/2"  
Width: 7"  
Boiler Diameter: 4 1/2"  
Cylinder Bore: 3 1/16"  
Stroke: 1 5/8"  
Wheel Outside Diameter: 5 1/4"



|                                   |       |
|-----------------------------------|-------|
| Full Drawing Set - 11 Sheets (A1) | 15159 |
|-----------------------------------|-------|

|                    |  |
|--------------------|--|
| Construction Notes |  |
|--------------------|--|

| Item / Product / Casting                | SKU     |
|-----------------------------------------|---------|
| Horn Block Pair (3 Req)                 | CF3     |
| Axle Box Strip                          | CE3     |
| Main Wheel - CI (6 Req)                 | 3HLW    |
| Brake Shoe Ring - CI                    | D11B    |
| Bogie Wheel - CI (4 Req)                | T30     |
| Bogie Bolster                           | 3HLBB   |
| Bogie Pin Bolster                       | 336P    |
| Pump Stay                               | EK119   |
| Axle Pump Body Tee                      | 164     |
| Pump Lubricator Eccentric Strap (2 Req) | 285L    |
| Motion Eccentric Strap                  | 289     |
| Bogie Horn (4 Req)                      |         |
| Bogie Axle Box Strip                    |         |
| Bogie Spring Beams (4 Req)              |         |
| Trailing Bracket                        | EK61    |
| Trailing Wheel - CI (2 Req)             | HLTW    |
| Trailing Spring (2 Req)                 | 3HLTGS  |
| Trailing Horn (2 Req)                   | 3HLTH   |
| Trailing Plain Axle Box Pair            | 3HL14   |
| Trailing Radial Axle Box (2 Req)        | EK60    |
| Piston Blank (3 Req) *                  | 219GM * |
| Inside Cylinder Elbow                   | EK121   |
| Inside Valve Guide Bracket              | 3HLIVG  |
| Inside Cylinder Pipe Connecting Bracket | EK123   |
| Outside Cylinder Flange                 | EK122   |
| Motion Bracket L/H                      | EK118   |
| Motion Bracket R/H                      | EK117   |
| Smoke Box Door Ring                     | CAY2    |
| Smoke Box Door                          | CAK1    |

| Item / Product / Casting    | SKU  |
|-----------------------------|------|
| Saddle                      | 3HL  |
| Chimney                     | HLDC |
| Dome                        | CW3  |
| Tender Brake Shoe Ring - CI | DC3  |
| Tender Spring (8 Req)       | HLTS |
| Tender Horn (8 Req)         | HLTH |
| Tender Axle Box (8 Req)     | 257  |
| Tender Wheel - CI (8 Req)   | HL7  |
| Hand Pump                   | 134  |
| Superheater End Blocks      | 70   |

| Slide Valve Cylinder Setup             |           |
|----------------------------------------|-----------|
| Inside Cylinder *                      | 3HLICSV * |
| Inside Cylinder Steam Chest *          | 3HLISC *  |
| Outside Cylinder (2 Req) *             | 3HLOCSV * |
| Outside Cylinder Steam Chest (2 Req) * | 3HLOS *   |
| Slide Valve (3 Req)                    | 3HLV      |

| Piston Valve Cylinder Setup         |           |
|-------------------------------------|-----------|
| Inside Cylinder *                   | 3HLICPV * |
| Outside Cylinder (2 Req) *          | 3HLOCPV * |
| Front Cover (2 Req) *               | 180F *    |
| Rear Cover (2 Req) *                | 198 *     |
| Piston Valve End Cover Pair (3 Req) | 3HLE      |

| Additional Product Requirements |         |
|---------------------------------|---------|
| Laser Cut Bogie Frame (2 Req)   | KEN311A |
| Laser Cut Main Frame (2 Req)    | KEN311B |
| Laser Cut Tender Frame (2 Req)  | KEN311C |

Products marked with an \* are available in alternative materials, please see the price sheet for further details

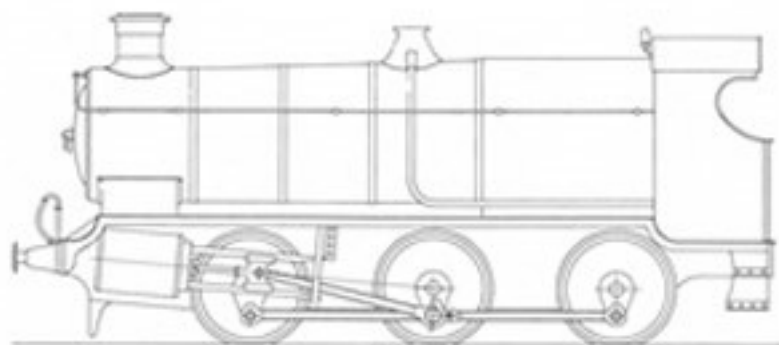

3 1/2" Gauge 0-6-0 GWR Tender  
Locomotive by L.B.S.C.

#### Specification

Overall Length (inc. Tender): 38"  
Width: 6 1/2"  
Boiler Diameter: 4"  
Cylinder Bore: 1 1/4"  
Stroke: 1 5/8"  
Wheel Outside Diameter: 3 5/8"



|                                  |       |
|----------------------------------|-------|
| Full Drawing Set - 7 Sheets (A1) | 15094 |
|----------------------------------|-------|

| Item / Product / Casting | SKU     |
|--------------------------|---------|
| Horn Block Pair (3 Req)  | CD1     |
| Main Axle Box Strip      | CE1     |
| Wheel - CI (6 Req)       | CBL     |
| Brake Shoe Ring - CI     | DE2     |
| Eccentric Strap (4 Req)  | 285L    |
| Guide Bar Bracket - L/H  | IRISLH  |
| Guide Bar Bracket - R/H  | IRISRH  |
| Smoke Box Door           | CAJ2    |
| Smoke Box Door Ring      | CAV2    |
| Chimney                  | IRISCH  |
| Cylinder Block (2 Req)   | IRISCYL |
| Steam Chest (2 Req)      | IRISSC  |
| Front Cover (2 Req)      | 180F    |
| Rear Cover (2 Req)       | EK19    |

| Item / Product / Casting                       | SKU     |
|------------------------------------------------|---------|
| Safety Valve Cover                             | IRISSVC |
| Piston Blank (2 Req)                           | 220GM   |
| <i>Piston Blank - CI (Alternative - 2 Req)</i> | 220CI   |
| Valve                                          | 5PV     |
| Tender Horn (6 Req)                            |         |
| Tender Axle Boxes Pair (3 Req)                 | 318     |
| Tender Wheel - CI (6 Req)                      | X206    |
| Tender Hand Pump                               | 132     |
| Tender Spring (6 Req)                          | K81     |

| Additional Product Requirements |         |
|---------------------------------|---------|
| Laser Cut Main Frame (2 Req)    | GLR303A |
| Laser Cut Tender Frame (2 Req)  | GLR303B |

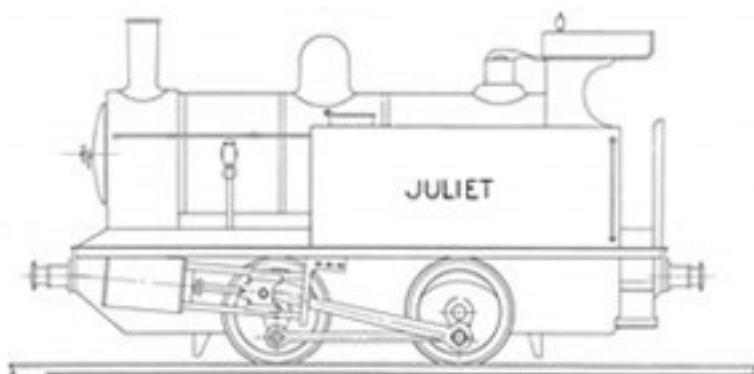

3 1/2" Gauge 0-4-0 Freeland Tank Locomotive by L.B.S.C.

### Specification

|                         |        |
|-------------------------|--------|
| Overall Length:         | 20"    |
| Width:                  | 6 1/2" |
| Boiler Diameter:        | 3 1/2" |
| Cylinder Bore:          | 1"     |
| Stroke:                 | 1 1/2" |
| Wheel Outside Diameter: | 3 1/4" |



|                                  |       |
|----------------------------------|-------|
| Full Drawing Set - 6 Sheets (A2) | 15047 |
|----------------------------------|-------|

| Item / Product / Casting                       | SKU          |
|------------------------------------------------|--------------|
| Horn Block Pair (2 Req)                        | CD1          |
| Axle Box Strip                                 | CE3          |
| Wheel - CI (4 Req)                             | RRW          |
| Brake Shoe Ring - CI                           | DD1          |
| Pump Stay                                      | 332          |
| Pump Body                                      | 166          |
| Eccentric Strap (5 Req)                        | 286          |
| Rear Cover (2 Req)                             | 5PRC         |
| Front Cover (2 Req)                            | 180F         |
| Piston Blank (2 Req)                           | 218GM        |
| <i>Piston Blank - CI (Alternative - 2 Req)</i> | <i>218CI</i> |
| Cylinder (2 Req)                               | RRC          |
| Steam Chest (2 Req)                            | RRSC         |

| Item / Product / Casting | SKU  |
|--------------------------|------|
| Valve Pair               | 3JV  |
| Exhaust Tee              | 118  |
| Saddle                   | 302  |
| Hand Pump                | 132  |
| Smoke Box Door           | CAJ2 |
| Smoke Box Door Ring      | CAT1 |
| Chimney                  | JU11 |
| Dome                     | JTD  |
| Superheater End Blocks   | 70   |

| Additional Product Requirements |        |
|---------------------------------|--------|
| Laser Cut Frame (2 Req)         | GLR051 |

| Boiler Material Kit                                                                                                                                                                                                                             | SKU             |
|-------------------------------------------------------------------------------------------------------------------------------------------------------------------------------------------------------------------------------------------------|-----------------|
| This kit includes all of the following materials,<br>5x Flanged Plates, Boiler Tube Material, Firebox Wrapper, Outer Wrapper Material, Joint Ring, Firehole Ring, Longitudinal Stays, Flue Tubes, Crown Stay Material, Foundation Ring Material | 3-12JUL-BOILKIT |



# Juliet - Outside Motion

## 3 1/2" Gauge

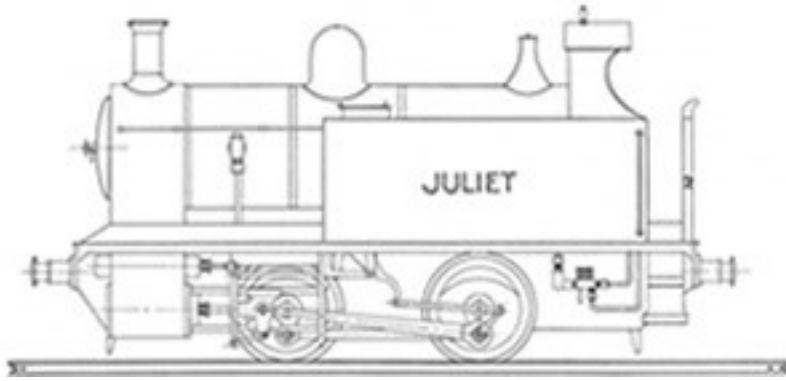

3 1/2" Gauge 0-4-0 Freelance Tank  
Locomotive by L.B.S.C.

### Specification

Overall Length: 20"  
Width: 6 1/2"  
Boiler Diameter: 3 1/2"  
Cylinder Bore: 1"  
Stroke: 1 1/2"  
Wheel Outside Diameter: 3 1/4"



|                                  |       |
|----------------------------------|-------|
| Full Drawing Set - 6 Sheets (A2) | 15046 |
|----------------------------------|-------|

| Item / Product / Casting                       | SKU          |
|------------------------------------------------|--------------|
| Horn Block Pair                                | CD1          |
| Axle Box Strip                                 | CE3          |
| Wheel - CI                                     | RRW          |
| Brake Shoe Ring - CI                           | DD1          |
| Pump Stay                                      | 332          |
| Pump Body                                      | 166          |
| Pump Eccentric                                 | 286          |
| Cylinder                                       | 3JOC         |
| Steam Chest                                    | 3JOSSC       |
| Piston Blank (2 Req)                           | 218GM        |
| <i>Piston Blank - CI (Alternative - 2 Req)</i> | <i>218CI</i> |
| Rear Cover                                     | 196          |
| Front Cover                                    | 179          |

| Item / Product / Casting | SKU  |
|--------------------------|------|
| Valve Pair               | 3JV  |
| Exhaust Tee              | 118  |
| Saddle                   | 302  |
| Hand Pump                | 132  |
| Smoke Box Door           | CAJ2 |
| Smoke Box Door Ring      | CAT1 |
| Chimney                  | JU11 |
| Dome                     | JTD  |
| Superheater End Blocks   | 70   |

| Additional Product Requirements |        |
|---------------------------------|--------|
| Laser Cut Frame (2 Req)         | GLR049 |

| Boiler Material Kit                                                                                                                                                                                                                                | SKU                 |
|----------------------------------------------------------------------------------------------------------------------------------------------------------------------------------------------------------------------------------------------------|---------------------|
| This kit includes all of the following materials,<br>5x Flanged Plates, Boiler Tube Material, Firebox Wrapper, Outer Wrapper Material, Joint Ring,<br>Firehole Ring, Longitudinal Stays, Flue Tubes, Crown Stay Material, Foundation Ring Material | 3-12JUL<br>-BOILKIT |

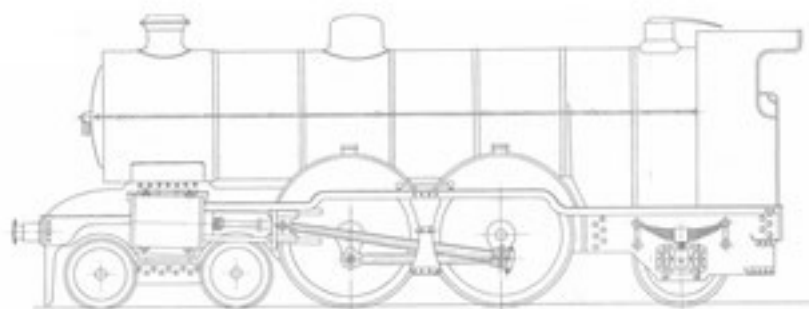

3 1/2" 4-4-2 Gauge GNR Tender Locomotive by L.B.S.C.

#### Specification

Overall Length (inc. Tender): 43 1/4"  
 Width: 6 1/2"  
 Boiler Diameter: 4 3/8"  
 Cylinder Bore: 1 1/4"  
 Stroke: 1 5/8"  
 Wheel Outside Diameter: 5"



|                                  |       |
|----------------------------------|-------|
| Full Drawing Set - 7 Sheets (A1) | 15059 |
|----------------------------------|-------|

| Item / Product / Casting             | SKU   |
|--------------------------------------|-------|
| Horn Block Pair (2 Req)              | CF1   |
| Axle Box Strip                       | CE2   |
| Driving Wheel - CI (2 Req)           | 3MDW  |
| Coupled Wheel - CI (2 Req)           | 3MCW  |
| Brake Shoe Ring - CI                 | DH1   |
| Bogie Horn (4 Req)                   | 325L  |
| Bogie Axle Box Strip                 | CF2   |
| Bogie Bolster                        | 334M  |
| Bogie Pin Bolster                    | 336   |
| Bogie Wheel - CI (4 Req)             | 262   |
| Guide Bar Yoke (2 Req)               | 3MGB  |
| Pump Stay                            | 287M  |
| Pump Body                            | 139R  |
| Pump Eccentric (5 Req)               | 286   |
| Trailing / Tender Wheel - CI (8 Req) | X206  |
| Trailing / Tender Horn (8 Req)       | 325   |
| Trailing / Tender Spring (8 Req)     | 3MTSP |
| Trailing / Tender Axle Box (8 Req)   | 250   |
| Cylinder (2 Req)                     | 3MC   |

| Item / Product / Casting                       | SKU          |
|------------------------------------------------|--------------|
| Steam Chest (2 Req)                            | 3MSC         |
| Front Cover (2 Req)                            | 180F         |
| Rear Cover (2 Req)                             | 180R         |
| Valve Pair                                     | 5TV          |
| Piston Blank (2 Req)                           | 220GM        |
| <i>Piston Blank - CI (Alternative - 2 Req)</i> | <i>220CI</i> |
| Smoke Box Door                                 | CAM2         |
| Smoke Box Door Ring                            | CAY2         |
| Dome                                           | CZ4          |
| Chimney                                        | CY2          |
| Safety Valve Cover                             | EK202        |
| Tender Hand Pump                               | 134          |
| Maisie Regulator Stand                         | REGM         |

| Additional Product Requirements |         |
|---------------------------------|---------|
| Laser Cut Bogie Frame (2 Req)   | GLR020B |
| Laser Cut Main Frame (2 Req)    | GLR020  |
| Laser Cut Tender Frame (2 Req)  | GLR020A |



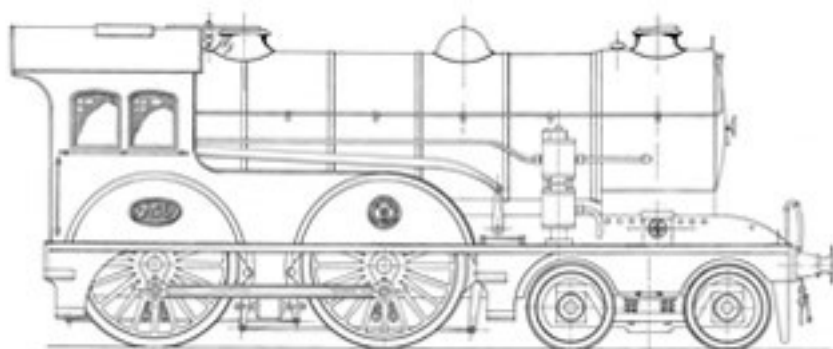

3 1/2" Gauge 4-4-0 NER Tender  
Locomotive by L.B.S.C.

## Specification

Overall Length (inc. Tender): 42"  
Width: 6 1/2"  
Boiler Diameter: 4 1/2"  
Cylinder Bore: 1 3/16"  
Stroke: 1 5/8"  
Wheel Outside Diameter: 5 1/4"



|                                  |       |
|----------------------------------|-------|
| Full Drawing Set - 8 Sheets (A2) | 15144 |
|----------------------------------|-------|

| Item / Product / Casting           | SKU   |
|------------------------------------|-------|
| Horn Block Pair (2 Req)            | CF1   |
| Main Axle Box Strip                | CE2   |
| Wheel - CI (4 Req)                 | X212  |
| Brake Shoe Ring - CI               | DH1   |
| Cylinder                           | 3NEC  |
| Steam Chest                        | 3NES  |
| Steam Chest Cover                  | 3NESC |
| Rear Cover (2 Req)                 |       |
| Front Cover (2 Req)                | 179   |
| Piston Blank (2 Req)               | 219GM |
| Valve Pair                         | 5TV   |
| Bogie / Tender Wheel - CI (10 Req) | 3BTEN |
| Bogie Axle Boxes                   | CG1   |
| Bogie Centre                       | 335R  |
| Bogie Equaliser (2 Req)            | 254R  |
| Chimney                            | 353R  |
| Dome                               | 353L  |

| Item / Product / Casting     | SKU   |
|------------------------------|-------|
| Hand Pump                    | 132   |
| Smoke Box Door               | CAK1  |
| Smoke Box Door Ring          | CAV1  |
| Tender Horn (6 Req)          | 325   |
| Tender Axle Box Pair (3 Req) | 3HL14 |
| Tender Brake Shoe Ring - CI  | DD1   |
| Superheater End Blocks       | 70    |

## Alternative Casting Material Options

|                           |        |
|---------------------------|--------|
| Cylinder - CI             | 3NECCI |
| Piston Blank - CI (2 Req) | 219CI  |

## Additional Product Requirements

|                                |         |
|--------------------------------|---------|
| Laser Cut Bogie Frame (2 Req)  | GLR304C |
| Laser Cut Main Frame (2 Req)   | GLR304A |
| Laser Cut Tender Frame (2 Req) | GLR304B |

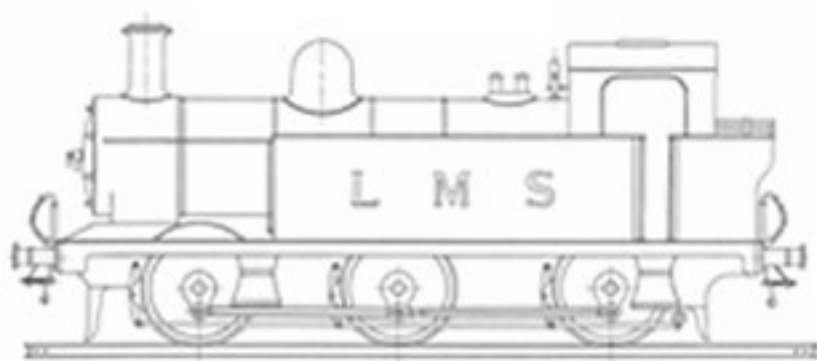

3 1/2" Gauge 0-6-0 LMS Class 3F Tank Locomotive by L.B.S.C.

### Specification

|                         |         |
|-------------------------|---------|
| Overall Length:         | 23 5/8" |
| Width:                  | 6 1/2"  |
| Boiler Diameter:        | 3 1/2"  |
| Cylinder Bore:          | 1 1/8"  |
| Stroke:                 | 1 3/8"  |
| Wheel Outside Diameter: | 3 5/8"  |



|                                  |       |
|----------------------------------|-------|
| Full Drawing Set - 6 Sheets (A1) | 15049 |
|----------------------------------|-------|

| Item / Product / Casting                       | SKU          |
|------------------------------------------------|--------------|
| Horn Block Pair (3 req)                        | CD1          |
| Axle Box Strip                                 | CE1          |
| Wheel - CI (6 Req)                             | CBM          |
| Brake Shoe Ring - CI                           | DE1          |
| Eccentric Strap (4 Req)                        | 285L         |
| Cylinder                                       | 3MYC         |
| Piston Blank (2 Req)                           | 219GM        |
| <i>Piston Blank - CI (Alternative - 2 Req)</i> | <i>219CI</i> |
| Steam Chest                                    | 3CTS         |
| Rear Cover (2 Req)                             | 195          |
| Front Cover (2 Req)                            | 179          |
| Valve Pair                                     | RRV          |

| Item / Product / Casting | SKU    |
|--------------------------|--------|
| Valve Buckle             | 3MBUC  |
| Motion Plate             | 3MP    |
| Hand Pump                | 134    |
| Smoke Box Door           | CAH1LH |
| Smoke Box Door Ring      | CAT1   |
| Chimney                  | CY3    |
| Dome                     | RRDOME |
| Superheater End Blocks   | 70     |
| Steam Chest Cover        | 3MYSCC |

| Additional Product Requirements |        |
|---------------------------------|--------|
| Laser Cut Main Frame (2 Req)    | GLR305 |

| Boiler Material Kit                                                                                                                                                                                                                                           | SKU                 |
|---------------------------------------------------------------------------------------------------------------------------------------------------------------------------------------------------------------------------------------------------------------|---------------------|
| This kit includes all of the following materials,<br>5x Flanged Plates, Boiler Tube Material, Firebox Wrapper, Outer Wrapper Material, Joint Strip, Firehole Ring, Longitudinal Stays, Flue Tubes, Crown Stay Material, Foundation Ring Material, Rivets Pack | 3-12MOL<br>-BOILKIT |



# Mona

## 3 1/2" Gauge

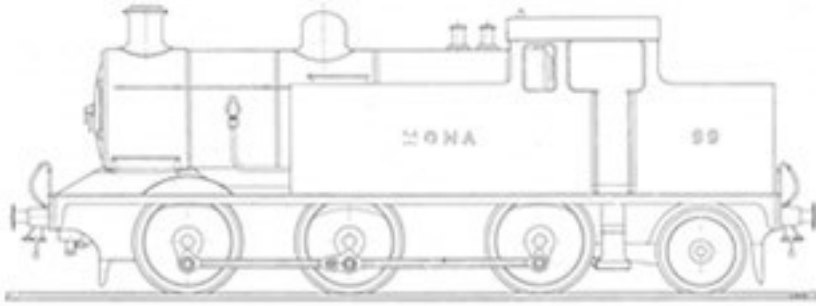

3 1/2" Gauge 0-6-2 Tank Locomotive by L.B.S.C.

### Specification

|                         |         |
|-------------------------|---------|
| Overall Length:         | 27 1/2" |
| Width:                  | 6 1/2"  |
| Boiler Diameter:        | 4"      |
| Cylinder Bore:          | 1 1/8"  |
| Stroke:                 | 1 5/8"  |
| Wheel Outside Diameter: | 3 3/4"  |



|                                   |       |
|-----------------------------------|-------|
| Full Drawing Set - 16 Sheets (A2) | 15050 |
|-----------------------------------|-------|

| Item / Product / Casting                       | SKU          |
|------------------------------------------------|--------------|
| Horn Block Pair (3 Req)                        | CD1          |
| Axle Box Strip                                 | CE1          |
| Main Wheel - CI (6 req)                        | CBM          |
| Trailing Wheel - CI (2 Req)                    | 3MON         |
| Brake Shoe Ring - CI                           | DE1          |
| Eccentric Strap (4 Req)                        | 285L         |
| Cylinder                                       | 3MYC         |
| Piston Blank (2 Req)                           | 219GM        |
| <i>Piston Blank - CI (Alternative - 2 Req)</i> | <i>219CI</i> |
| Steam Chest Cover                              | 3MYSCC       |
| Rear Cover (2 Req)                             | 195          |
| Front Cover (2 Req)                            | 179          |

| Item / Product / Casting | SKU    |
|--------------------------|--------|
| Valve Pair               | RRV    |
| Chimney                  | CX2    |
| Dome                     | PVDOME |
| Smoke Box Door           | CAK2   |
| Smoke Box Door Ring      | CAT1   |
| Hand Pump                | 134    |
| Superheater End Blocks   | 70     |

| Additional Product Requirements |        |
|---------------------------------|--------|
| Laser Cut Main Frames (2 Req)   | GLR306 |

| Boiler Material Kit                                                                                                                                                                                                                              | SKU                      |
|--------------------------------------------------------------------------------------------------------------------------------------------------------------------------------------------------------------------------------------------------|--------------------------|
| This kit includes all of the following materials,<br>5x Flanged Plates, Boiler Tube Material, Firebox Wrapper, Outer Wrapper Material, Firehole Ring, Longitudinal Stays, Flue Tubes, Crown Stay Material, Foundation Ring Material, Rivets Pack | 3-12<br>MONA<br>-BOILKIT |



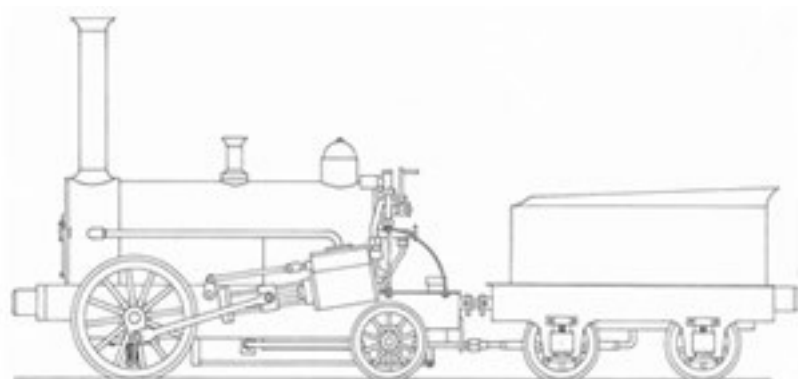

3 1/2" Gauge Rocket Type 0-2-2 Tender Locomotive by Tony Weale

### Specification

Overall Length (inc. Tender): 21 9/16"  
 Width: 5 1/8"  
 Boiler Diameter: 3"  
 Cylinder Bore: 1 1/16"  
 Stroke: 1 1/8"  
 Wheel Outside Diameter: 3 3/4"



Northumbrian was based on Rainhill and is ideal for beginners.

|                                   |       |
|-----------------------------------|-------|
| Full Drawing Set - 10 Sheets (A2) | 15058 |
|-----------------------------------|-------|

|                    |  |
|--------------------|--|
| Construction Notes |  |
|--------------------|--|

| Item / Product / Casting                       | SKU          |
|------------------------------------------------|--------------|
| Axle Box Strip                                 | CB3          |
| Driving Wheel - CI (2 Req)                     | 3RDW         |
| Trailing / Tender Wheel - CI (6 Req)           | 233          |
| Axle Pump Body                                 | 164          |
| Eccentric Strap (3 Req)                        | NB           |
| Cylinder (2 Req)                               | 3CLC         |
| Steam Chest (2 Req)                            | 3RSC         |
| Rear Cover (2 Req)                             | 193          |
| Front Cover (2 Req)                            | 178          |
| Piston Bank (2 Req)                            | 218GM        |
| <i>Piston Blank - CI (Alternative - 2 Req)</i> | <i>218CI</i> |
| Valve Pair                                     | 3TV          |

| Item / Product / Casting | SKU   |
|--------------------------|-------|
| Superheater End Blocks   | 71    |
| Chimney Base             | 3RHC  |
| Dome                     | CK1   |
| Hand Pump                | 134   |
| Tender Axle Box Strip    | CBBB1 |

| Additional Product Requirements |        |
|---------------------------------|--------|
| Laser Cut Main Frame (2 Req)    | GLR003 |
| Laser Cut Tender Frame (2 Req)  | GLR042 |
| Wood Lagging Kit                |        |
| O Ring Set                      |        |

| Boiler Material Kit                                                                                                                                                                                                         | SKU                       |
|-----------------------------------------------------------------------------------------------------------------------------------------------------------------------------------------------------------------------------|---------------------------|
| This kit includes all of the following materials,<br>5x Flanged Plates, Boiler Tube Material, Firebox Wrapper, Firehole Ring, Longitudinal Stays,<br>Flue Tubes, Crown Stay Material, Foundation Ring Material, Rivets Pack | 3-12<br>NORTH<br>-BOILKIT |



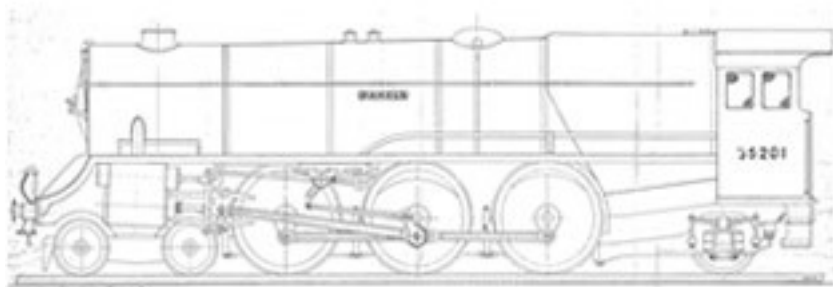

3 1/2" Gauge 4-6-2 Pacific Tender  
Locomotive by L.B.S.C.

### Specification

Overall Length (inc. Tender): 51"  
Width: 6 3/4"  
Boiler Diameter (Tapers to): 4 1/2"  
Cylinder Bore: 1 5/16"  
Stroke: 1 1/2"  
Wheel Outside Diameter: 4 7/8"



|                                   |       |
|-----------------------------------|-------|
| Full Drawing Set - 11 Sheets (A1) | 15164 |
|-----------------------------------|-------|

| Item / Product / Casting                       | SKU          |
|------------------------------------------------|--------------|
| Horn Block Pair                                | CD1          |
| Axle Box Strip                                 | CE1          |
| Pump Stay                                      | 332          |
| Axle Pump                                      | 164          |
| Pump Eccentric Strap                           | 287L         |
| Driving Wheel - CI (2 Req)                     | KB2          |
| Coupled Wheel - CI (4 Req)                     | KB3          |
| Brake Shoe Ring - CI                           | DJ1          |
| Lubricator Eccentric Strap                     | 285L         |
| Cylinder                                       | 3PAMC        |
| Front Cover (2 Req)                            | 197          |
| Rear Cover (2 Req)                             | 196          |
| Piston Blank (2 Req)                           | 220GM        |
| <i>Piston Blank - CI (Alternative - 2 Req)</i> | <i>220CI</i> |
| Bogie Wheel - CI (4 Req)                       | 3DBW         |
| Bogie Pin Bolster                              | 336P         |
| Bogie / Pony Axle Box Strip                    | CF2          |
| Bogie Bolster                                  | 334P         |
| Bogie / Tender Horn (10 Req)                   | 325          |

| Item / Product / Casting         | SKU   |
|----------------------------------|-------|
| Guide Bar Bracket (Pair)         | 255   |
| Smoke Box Door                   | CAK1  |
| Smoke Box Door Ring              | CAY2  |
| Saddle                           | HIS   |
| Dome                             | 114L  |
| Chimney                          | 353R  |
| Tender Spring (6 Req)            | 1000  |
| Tender Axle Box Pair (3 Req)     | 3HL14 |
| Tender / Pony Wheel - CI (8 Req) | HLTW  |
| Tender Brake Shoe Ring - CI      | DC2   |
| Tender Hand Pump                 | 134   |
| Pony Cast Spring (2 Req)         | 344   |
| Pony Horn (2 Req)                | 3HLTH |

| Additional Product Requirements |         |
|---------------------------------|---------|
| Laser Cut Bogie Frame (2 Req)   | GLR307B |
| Laser Cut Main Frame (2 Req)    | GLR307  |
| Laser Cut Tender Frame (2 Req)  | GLR307A |



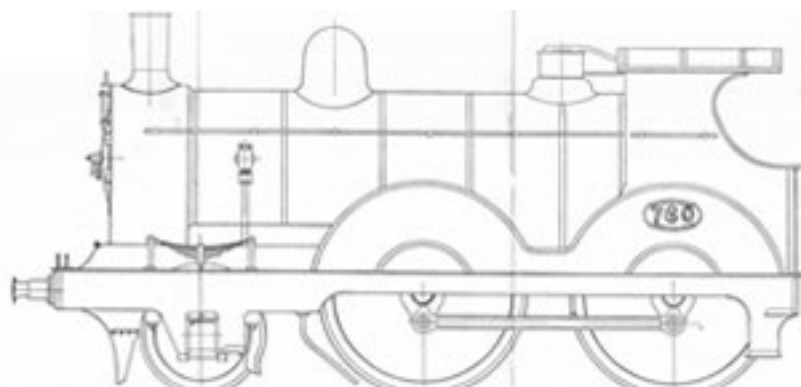

3 1/2" 2-4-0 Gauge GER Tender  
Locomotive by L.B.S.C.

### Specification

|                               |        |
|-------------------------------|--------|
| Overall Length (inc. Tender): | 35"    |
| Width:                        | 6"     |
| Boiler Diameter:              | 3 1/2" |
| Cylinder Bore:                | 1 1/8" |
| Stroke:                       | 1 1/2" |
| Wheel Outside Diameter:       | 5 1/2" |



|                                  |       |
|----------------------------------|-------|
| Full Drawing Set - 7 Sheets (A2) | 15053 |
|----------------------------------|-------|

| Item / Product / Casting                       | SKU          |
|------------------------------------------------|--------------|
| Horn Block Pair (2 Req)                        | CD1          |
| Axle Box Strip                                 | CE1          |
| Driving Wheel - CI                             | PETDW        |
| Coupled Wheel - CI                             | PETCW        |
| Leading Wheel - CI                             | PETLW        |
| Brake Shoe Ring - CI                           | DJ2          |
| Leading Wheel Cast Spring (2 Req)              | 3PLS         |
| Leading Wheel Axle Box Strip                   | CE3-HALF     |
| Motion Eccentric Strap (4 Req)                 | 286          |
| Piston Bank (2 Req)                            | 219GM        |
| <i>Piston Blank - CI (Alternative - 2 Req)</i> | <i>219CI</i> |
| Cylinder                                       | 3COTC        |
| Steam Chest                                    | 3CTS         |
| Vave Pair                                      | RRV          |
| Valve Buckle (2 Req)                           | 3MBUC        |
| Front Cover                                    | P38          |
| Rear Cover                                     | P3C          |
| Motion Plate                                   | P7           |

| Item / Product / Casting     | SKU    |
|------------------------------|--------|
| Smoke Box Door               | CAK2   |
| Smoke Box Door Ring          | CAT1   |
| Dome                         | PVDOME |
| Chimney                      | CZ1    |
| Safety Valve Cover           | CZ2    |
| Superheater End Blocks       | 71     |
| Tender Horn (6 Req)          | 3PTH   |
| Tender Spring (6 Req)        | 3PTS   |
| Tender Axle Box Pair (3 Req) | 3PTAB  |
| Tender Wheel - CI            | 3PTW   |
| Tender Brake Shoe Ring - CI  | DC3    |
| Tender Hand Pump             | 132    |

| Additional Product Requirements    |         |
|------------------------------------|---------|
| Laser Cut Outer Main Frame (2 Req) | GLR308B |
| Laser Cut Inner Main Frame (2 Req) | GLR308  |
| Laser Cut Tender Frame (2 Req)     | GLR308A |

| Boiler Material Kit                                                                                                                                                                                                                                                | SKU                 |
|--------------------------------------------------------------------------------------------------------------------------------------------------------------------------------------------------------------------------------------------------------------------|---------------------|
| This kit includes all of the following materials,<br>5x Flanged Plates, Boiler Tube Material, Firebox Wrapper, Outer Wrapper Material, Joint Ring,<br>Firehole Ring, Longitudinal Stays, Flue Tubes, Crown Stay Material, Foundation Ring Material,<br>Rivets Pack | 3-12PET<br>-BOILKIT |

# PV Baker

# 3 1/2" Gauge

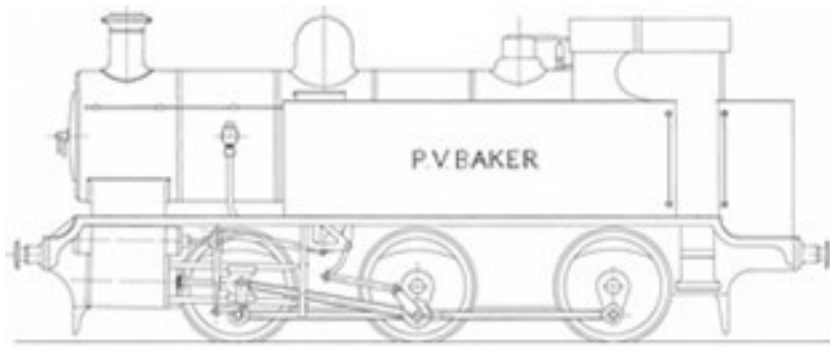

3 1/2" Gauge 0-6-0 Freelance Tank  
Locomotive by L.B.S.C.

### Specification

|                         |        |
|-------------------------|--------|
| Overall Length:         | 25"    |
| Width:                  | 7"     |
| Boiler Diameter:        | 4"     |
| Cylinder Bore:          | 1 1/8" |
| Stroke:                 | 1 3/4" |
| Wheel Outside Diameter: | 3 5/8" |

PV Baker is a very fine performer and a very neat looking loco for the enthusiast who would like to depart from the run of the mill type of engine



|                                  |       |
|----------------------------------|-------|
| Full Drawing Set - 6 Sheets (A1) | 15048 |
|----------------------------------|-------|

| Item / Product / Casting                       | SKU          |
|------------------------------------------------|--------------|
| Horn Block Pair (3 Req)                        | CD1          |
| Main Axle Box Strip (3 Req)                    | CE1          |
| Wheel - CI                                     | PVBDW        |
| Brake Shoe Ring - CI                           | DE1          |
| Axle Pump                                      | 164          |
| Eccentric Strap                                | 285L         |
| Pump Stay                                      | 332          |
| Cylinder (2 Req)                               | PVBC         |
| Steam Chest Liner (2 Req)                      | 3DL          |
| Piston Valve Rear Cover (2 Req)                | PV7          |
| Front Cover (2 Req)                            | RRFC         |
| Rear Cover (2 Req)                             | RRRC         |
| Piston Blank (2 Req)                           | 219GM        |
| <i>Piston Blank - CI (Alternative - 2 Req)</i> | <i>219CI</i> |

| Item / Product / Casting | SKU    |
|--------------------------|--------|
| Guide Yoke (2 Req)       | PVBGB  |
| Chimney                  | CY3    |
| Safety Valve Cover       | CZ2    |
| Dome                     | PVDOME |
| Hand Pump                | 134    |
| Smoke Box Door           | CAH1   |
| Smoke Box Door Ring      | CAV2   |
| Superheater End Blocks   | 70     |

| Additional Product Requirements |        |
|---------------------------------|--------|
| Laser Cut Main Frame (2 Req)    | GLR309 |

| Boiler Material Kit                                                                                                                                                                                                                                | SKU                 |
|----------------------------------------------------------------------------------------------------------------------------------------------------------------------------------------------------------------------------------------------------|---------------------|
| This kit includes all of the following materials,<br>5x Flanged Plates, Boiler Tube Material, Firebox Wrapper, Outer Wrapper Material, Joint Ring,<br>Firehole Ring, Longitudinal Stays, Flue Tubes, Crown Stay Material, Foundation Ring Material | 3-12PVB<br>-BOILKIT |



3 1/2" Gauge 0-2-2 Rocket Type Tender Locomotive by L.B.S.C.

### Specification

Overall Length (inc. Tender): 23"  
 Width: 4 3/8"  
 Boiler Diameter: 3"  
 Cylinder Bore: 1 1/16"  
 Stroke: 1 1/8"  
 Wheel Outside Diameter: 3 5/8"



Original text from 1955 Kennion Brothers catalogue which still holds true today; 'Easy to build, easy to run. Has pulled an adult and a child together. As the name "Rocket" implies, this engine follows the earliest types and creates considerable interest wherever it is built or shown.

|                                  |       |
|----------------------------------|-------|
| Full Drawing Set - 4 Sheets (A4) | 15057 |
|----------------------------------|-------|

|                    |  |
|--------------------|--|
| Construction Notes |  |
|--------------------|--|

| Item / Product / Casting                       | SKU          |
|------------------------------------------------|--------------|
| Horn Block (2 Req)                             | CA           |
| Axle Box Strip                                 | CB3          |
| Driving Wheel - CI (2 Req)                     | 3RDW         |
| Trailing / Tender Wheel - CI (6 Req)           | 233          |
| Pump Stay                                      | 331R         |
| Axle Pump Body                                 | 163          |
| Eccentric Strap (3 Req)                        | 285S         |
| Cylinder (2 Req)                               | 3CLC         |
| Piston Blank (2 Req)                           | 218GM        |
| <i>Piston Blank - CI (Alternative - 2 Req)</i> | <i>218CI</i> |
| Steam Chest (2 Req)                            | 3RSC         |
| Front Cover (2 Req)                            | 178          |
| Rear Cover (2 Req)                             | 193          |

| Item / Product / Casting | SKU   |
|--------------------------|-------|
| Valve Pair               | 3TV   |
| Superheater End Blocks   | 71    |
| Dome                     | CK1   |
| Chimney Base             | 3RHC  |
| Hand Pump                | 133   |
| Tender Axle Box Strip    | CBBB1 |

| Additional Product Requirements |        |
|---------------------------------|--------|
| Laser Cut Main Frame (2 Req)    | GLR001 |
| Laser Cut Tender Frame (2 Req)  | GLR002 |
| O-Ring Set                      |        |

| Boiler Material Kit                                                                                                                                                                                            | SKU                  |
|----------------------------------------------------------------------------------------------------------------------------------------------------------------------------------------------------------------|----------------------|
| This kit includes all of the following materials,<br>5x Flanged Plates, Boiler Tube Material, Firebox Wrapper, Firehole Ring, Longitudinal Stays,<br>Flue Tubes, Crown Stay Material, Foundation Ring Material | 3-12RAIN<br>-BOILKIT |



# Rob Roy

## 3 1/2" Gauge

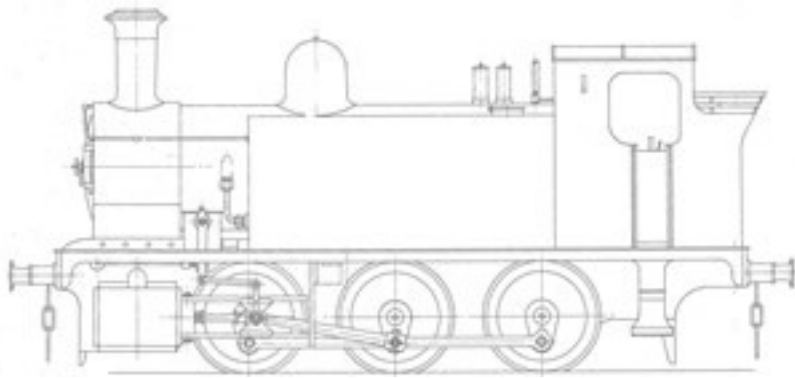

3 1/2" Gauge 0-6-0 Caledonian Railway  
Tank Locomotive by Martin Evans

### Specification

|                         |        |
|-------------------------|--------|
| Overall Length:         | 21"    |
| Width:                  | 7"     |
| Boiler Diameter:        | 3 1/4" |
| Cylinder Bore:          | 15/16" |
| Stroke:                 | 1 3/8" |
| Wheel Outside Diameter: | 3 1/4" |

Very popular with beginners, this locomotive was originally offered as a competition organised by 'Model Engineer'. These locomotives were built for the Caledonian Railway for dockyards where tight radius curves had to be negotiated.



|                                  |       |
|----------------------------------|-------|
| Full Drawing Set - 6 Sheets (A2) | 15045 |
|----------------------------------|-------|

|                    |  |
|--------------------|--|
| Construction Notes |  |
|--------------------|--|

| Item / Product / Casting                       | SKU          |
|------------------------------------------------|--------------|
| Horn Block Pair                                | CD1          |
| Axle Box Strip                                 | CE1          |
| Wheel - CI (6 Req)                             | RRW          |
| Brake Shoe Ring - CI                           | DD1          |
| Eccentric Strap (4 Req)                        | 285L         |
| Cylinder (2 Req)                               | RRC          |
| Piston Blank (2 Req)                           | 218GM        |
| <i>Piston Blank - CI (Alternative - 2 Req)</i> | <i>218CI</i> |
| Steam Chest (2 Req)                            | RRSC         |
| Front Cover (2 Req)                            | RRFC         |
| Rear Cover (2 Req)                             | RRRC         |
| Valve Pair                                     | RRV          |

| Item / Product / Casting | SKU    |
|--------------------------|--------|
| Crosshead Pump           | 247SQ  |
| Hand Pump                | 132    |
| Smoke Box Door           | CAH1   |
| Smoke Box Door Ring      | CAT2   |
| Smoke Box Saddle         | 303    |
| Chimney                  | CX4    |
| Dome                     | RRDOME |
| Superheater End Blocks   | 70     |

| Additional Product Requirements |        |
|---------------------------------|--------|
| Laser Cut Main Frame (2 Req)    | GLR046 |

| Boiler Material Kit                                                                                                                                                                                                                              | SKU                |
|--------------------------------------------------------------------------------------------------------------------------------------------------------------------------------------------------------------------------------------------------|--------------------|
| This kit includes all of the following materials,<br>5x Flanged Plates, Boiler Tube Material, Firebox Wrapper, Outer Wrapper Extension Material,<br>Firehole Ring, Longitudinal Stays, Flue Tubes, Crown Stay Material, Foundation Ring Material | 3-12RR<br>-BOILKIT |

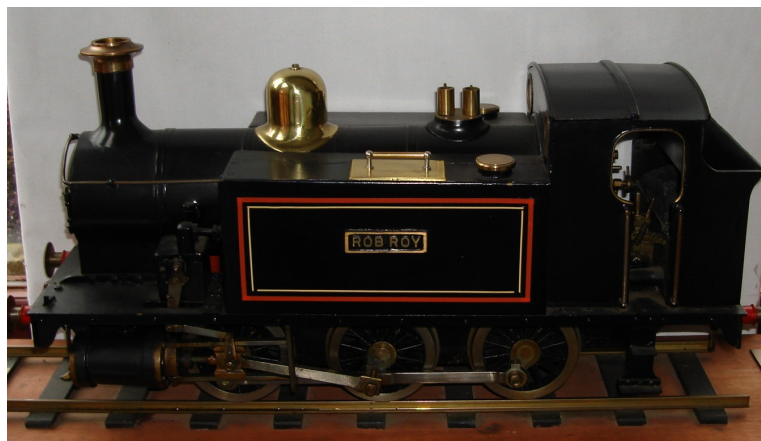

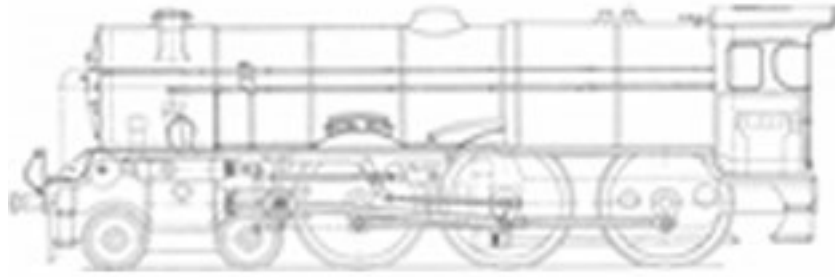

3 1/2" Royal Scot 4-6-0 LMSR Express  
Locomotive by Henry Greenly

**Specification**

Overall Length (inc. Tender):  
Width: 6 23/32"  
Boiler Diameter: 4 1/2"  
Cylinder Bore: 1 1/8"  
Stroke: 1 3/4"  
Wheel Tread Diameter: 5 1/16"



|                                    |       |
|------------------------------------|-------|
| Full Drawing Set - 8 Sheets (A1/L) | 15161 |
|------------------------------------|-------|

| Item / Product / Casting           | SKU   |
|------------------------------------|-------|
| Horn Cheek                         | RSHB  |
| Axle Box Strip                     | CE2   |
| Bogie Axle Box Strip               | RSBAB |
| Driving Wheel - CI (2 Req)         | 3RSDW |
| Coupled Wheel - CI (4 Req)         | 3RSCW |
| Bogie / Tender Wheel - CI (10 Req) | 3BLTW |

| Item / Product / Casting     | SKU |
|------------------------------|-----|
| Cylinder Block (2 Req)       | 3DC |
| Front Cylinder Cover (2 Req) | 197 |
| Rear Cylinder Cover (2 Req)  | 196 |

| Additional Product Requirements |         |
|---------------------------------|---------|
| Laser Cut Bogie Frame (2 Req)   | KEN312A |
| Laser Cut Main Frame (2 Req)    | KEN312B |
| Laser Cut Tender Frame (2 Req)  | KEN312C |



# Tich - Small Boiler

## 3 1/2" Gauge

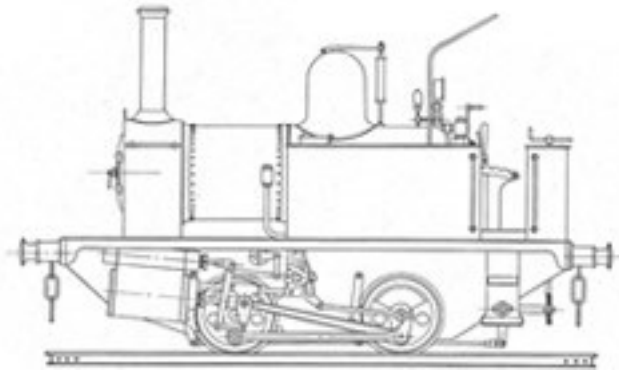

3 1/2" Gauge 0-4-0 Dock Shunting Tank Locomotive by L.B.S.C.

### Specification

|                         |         |
|-------------------------|---------|
| Overall Length:         | 15 1/2" |
| Width:                  | 6 3/8"  |
| Boiler Diameter:        | 2 1/2"  |
| Cylinder Bore:          | 11/16"  |
| Stroke:                 | 1 1/8"  |
| Wheel Outside Diameter: | 2 1/4"  |

Small boiler version of our very popular 'first time' straight forward locomotive to build which is capable of pulling 3 adults. Larger Boiler version also available.



|                                   |       |
|-----------------------------------|-------|
| Full Drawing Set - 10 Sheets (A1) | 15052 |
|-----------------------------------|-------|

| Item / Product / Casting                       | SKU   |
|------------------------------------------------|-------|
| Horn Block Pair (2 Req)                        | 25H   |
| Main Axle Box Strip                            | CB1   |
| Wheel - CI (4 Req)                             | 3TW   |
| Brake Shoe Ring - CI                           | TBS   |
| Pump Stay                                      | 119   |
| Axle Pump Body                                 | 120   |
| Pump Eccentric                                 | 298   |
| Cylinder Block (2 Req)                         | 3TC   |
| Steam Chest (2 Req)                            | 3TSC  |
| Front Cylinder Cover (2 Req)                   | 178   |
| Rear Cylinder Cover (2 Req)                    | 50    |
| Valve Pair                                     | 3TV   |
| Piston Blank (2 Req)                           | 218GM |
| <i>Piston Blank - CI (Alternative - 2 Req)</i> | 218CI |
| Exhaust Tee                                    | 118   |
| Steam Tee Pipe Collector                       | 247   |

| Item / Product / Casting | SKU     |
|--------------------------|---------|
| Guide Bar Bracket L/H    | 121L    |
| Guide Bar Bracket R/H    | 121R    |
| Smoke Box Front          | 127     |
| Small Boiler Door        | TSDB    |
| Chimney                  | CO1     |
| Small Boiler Dome        | CZ3     |
| Grate - CI               | 3TGRATE |
| Superheater End Blocks   | 71      |
| Hand Pump                | 132     |

| Additional Product Requirements |        |
|---------------------------------|--------|
| Laser Cut Main Frame (2 Req)    | GLR050 |
| Axle Box Spring (8 Req)         |        |
| Drag Hook Spring                |        |
| <i>Buffer Spring (4 Req)</i>    |        |

| Boiler Material Kit                                                                                                                                                                                             | SKU                    |
|-----------------------------------------------------------------------------------------------------------------------------------------------------------------------------------------------------------------|------------------------|
| This kit includes all of the following materials,<br>5x Flanged Plates, Boiler Sheet Material, Firebox Wrapper, Firehole Ring, Longitudinal Stays,<br>Flue Tubes, Crown Stay Material, Foundation Ring Material | 3-12TICH<br>SB-BOILKIT |





3 1/2" Gauge 0-4-0 Dock Shunting Tank Locomotive by L.B.S.C.

### Specification

Overall Length: 15 1/2"  
 Width: 6 3/8"  
 Boiler Diameter: 3"  
 Cylinder Bore: 1 1/16"  
 Stroke: 1 1/8"  
 Wheel Outside Diameter: 2 1/4"



Large boiler version of our very popular 'first time' straight forward locomotive to build which is capable of pulling 3 adults. Smaller Boiler version also available.

|                                   |       |
|-----------------------------------|-------|
| Full Drawing Set - 11 Sheets (A1) | 15051 |
|-----------------------------------|-------|

| Item / Product / Casting                       | SKU   |
|------------------------------------------------|-------|
| Horn Block Pair (2 Req)                        | 25H   |
| Axle Box Strip                                 | CB1   |
| Wheel - CI (4 Req)                             | 3TW   |
| Brake Shoe Ring                                | TBS   |
| Pump Stay                                      | 119   |
| Axle Pump Body                                 | 120   |
| Pump Eccentric                                 | 298   |
| Cylinder Block                                 | 3TC   |
| Steam Chest                                    | 3TSC  |
| Front Cylinder Cover                           | 178   |
| Rear Cylinder Cover                            | 50    |
| Valve Pair                                     | 3TV   |
| Piston Blank                                   | 218GM |
| <i>Piston Blank - CI (Alternative - 2 Req)</i> | 218CI |
| Exhaust Tee                                    | 118   |
| Steam Tee Pipe Collector                       | 247   |

| Item / Product / Casting    | SKU     |
|-----------------------------|---------|
| Guide Bar Bracket L/H       | 121L    |
| Guide Bar Bracket R/H       | 121R    |
| Large Boiler Door           | CAG1    |
| Large Boiler Smoke Box Ring | CAB1 L  |
| Large Boiler Saddle         | 126     |
| Chimney                     | CO1     |
| Large Boiler Dome           | CO3     |
| Grate - CI                  | 3TGRATE |
| Superheater End Blocks      | 71      |
| Hand Pump                   | 132     |

| Additional Product Requirements |        |
|---------------------------------|--------|
| Laser Cut Main Frame (2 Req)    | GLR050 |
| Axle Box Spring (8 Req)         |        |
| Drag Hook Spring                |        |
| Buffer Spring (4 Req)           |        |

| Boiler Material Kit                                                                                                                                                                                             | SKU                    |
|-----------------------------------------------------------------------------------------------------------------------------------------------------------------------------------------------------------------|------------------------|
| This kit includes all of the following materials,<br>5x Flanged Plates, Boiler Sheet Material, Firebox Wrapper, Firehole Ring, Longitudinal Stays,<br>Flue Tubes, Crown Stay Material, Foundation Ring Material | 3-12TICH<br>LB-BOILKIT |



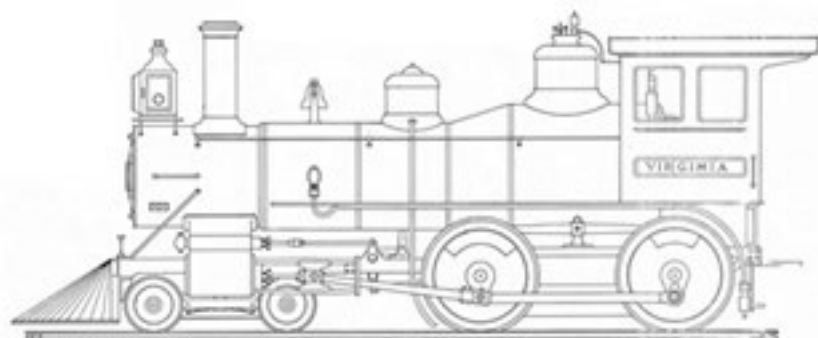

3 1/2" Gauge 4-4-0 Old Style American  
Tender Locomotive by L.B.S.C.

#### Specification

Overall Length (inc. Tender): 44 1/2"  
Width: 5 1/2"  
Boiler Diameter: 3 3/4"  
Cylinder Bore: 1 1/16"  
Stroke: 1 1/2"  
Wheel Outside Diameter: 4 1/8"



|                                   |       |
|-----------------------------------|-------|
| Full Drawing Set - 11 Sheets (A1) | 15158 |
|-----------------------------------|-------|

| Item / Product / Casting                       | SKU          |
|------------------------------------------------|--------------|
| Axle Box Strip                                 | CE1          |
| Driving Wheel - CI (2 Req)                     | CBU          |
| Coupled Wheel - CI (2 Req)                     | CBJ          |
| Main Spring Casting (4 Req)                    | 341          |
| Bogie / Tender Spring Casting (6 Req)          | 34GM         |
| Equaliser Bar (2 Req)                          | 182          |
| Axle Pump Body                                 | 24A          |
| Eccentric Strap (5 Req)                        | 285L         |
| Bogie Axle Box Strip                           | CF2          |
| Bogie Wheel - CI (4 Req)                       | CBB          |
| Bogie Equaliser (2 Req)                        |              |
| Cylinder Block (2 Req)                         | 3VC          |
| Steam Chest (2 Req)                            | 3VSC         |
| Front Cylinder Cover (2 Req)                   | 179          |
| Rear Cylinder Cover (2 Req)                    | 196          |
| Piston Blank (2 Req)                           | 219GM        |
| <i>Piston Blank - CI (Alternative - 2 Req)</i> | <i>219CI</i> |
| Valve Pair                                     | 3VV          |
| Buckle Pair                                    | 3V4          |
| Saddle                                         | 304          |

| Item / Product / Casting      | SKU        |
|-------------------------------|------------|
| Chimney                       | CM2        |
| Dome                          | CM3        |
| Sand Dome                     | CM4        |
| Smoke Box Door & Front        | 238        |
| Super Heater End Blocks       | 70         |
| Tender Wheel - CI (8 Req)     | CBT        |
| Tender Axle Box Strip (2 Req) | 184        |
| Tender Equaliser (4 Req)      |            |
| <i>Tender Bolster (2 Req)</i> | <i>185</i> |
| Tender Hand Pump              | 132        |

| Large Boiler Alternatives |      |
|---------------------------|------|
| Chimney                   | CM5  |
| Dome                      | CM6  |
| Sand Dome                 | CM7  |
| Smoke Box Door & Front    | 239V |

| Additional Product Requirements |        |
|---------------------------------|--------|
| Laser Cut Main Frame (2 Req)    | KEN313 |



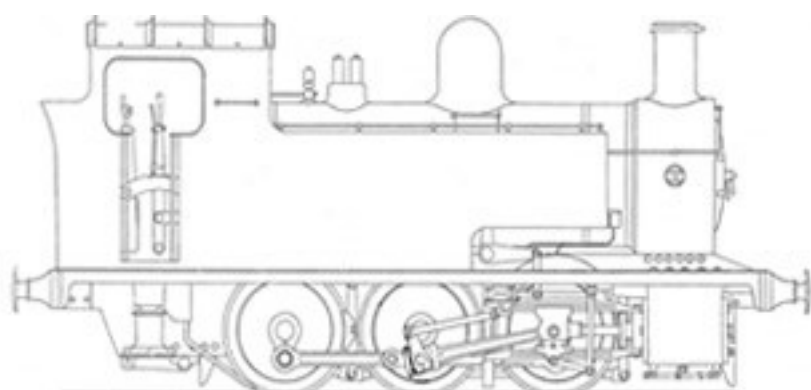

5" Gauge 0-6-0 Tank Locomotive by  
Charles Kennion

#### Specification

|                         |         |
|-------------------------|---------|
| Overall Length:         | 29"     |
| Width:                  | 9 1/2"  |
| Boiler Diameter:        | 4 1/2"  |
| Cylinder Bore:          | 1 3/8"  |
| Stroke:                 | 1 7/8"  |
| Wheel Outside Diameter: | 4 7/16" |



Butch has proved itself to be the finest 5" gauge tank locomotive ever to be offered for building; as a club loco it cannot be surpassed. On a circular track it has pulled 30cwt.

|                                   |       |
|-----------------------------------|-------|
| Full Drawing Set - 12 Sheets (A1) | 15067 |
|-----------------------------------|-------|

| Item / Product / Casting                       | SKU          |
|------------------------------------------------|--------------|
| Horn Block Pair (3 Req)                        | AQ           |
| Axle Box Pair (3 Req)                          | AV           |
| Wheel - CI (6 Req)                             | 5BW          |
| Brake Shoe Ring - CI                           | DF2          |
| Pump Stay                                      | BA2          |
| Pump Body (2 Req)                              | BB2          |
| Pump Stand                                     | BB8          |
| Eccentric Strap (2 Req)                        | 288          |
| Hand Pump                                      | BB1          |
| Exhaust Tee                                    | BC3          |
| Cylinder Block                                 | 5BCC         |
| Steam Chest                                    | 5BSC         |
| Front Cylinder Cover                           | DS2          |
| Rear Cylinder Cover                            | DS1          |
| Valve Pair                                     | 5BV          |
| Piston Blank                                   | 220GM        |
| <i>Piston Blank - CI (Alternative - 2 Req)</i> | <i>220CI</i> |
| Piston Gland Pair                              | 5BG          |
| Crosshead (2 Req)                              | BD1          |

| Item / Product / Casting            | SKU  |
|-------------------------------------|------|
| Buckle (2 Req)                      | 5BB  |
| Front Valve Guide Rod (2 Req)       | BB0  |
| Guide Bar Motion Bracket (2 Req)    | BA1  |
| Expansion Link Bearing Pair         | BB3  |
| Smoke Box To Boiler Connection Ring | BC1  |
| Smoke Box Front                     | BC2  |
| Smoke Box Door                      | CAK1 |
| Chimney                             | CAA3 |
| Safety Valve Base                   | CAA2 |
| Superheater End Blocks              | 70   |
| Grate - CI                          | 5BGR |
| Dome                                | CAA1 |

| Additional Product Requirements |          |
|---------------------------------|----------|
| Name Plate                      | BUTNPGM  |
| Laser Cut Main Frame L/H        | GLR052LH |
| Laser Cut Main Frame R/H        | GLR052RH |
| Axle Box Spring (8 Req)         |          |
| O-Ring Set                      |          |

| Boiler Material Kit                                                                                                                                                                                                                                                 | SKU              |
|---------------------------------------------------------------------------------------------------------------------------------------------------------------------------------------------------------------------------------------------------------------------|------------------|
| This kit includes all of the following materials,<br>5x Flanged Plates, Boiler Tube Material, Firebox Wrapper, Outer Wrapper Material, Joint Strip,<br>Firehole Ring, Longitudinal Stays, Flue Tubes, Crown Stay Material, Foundation Ring Material,<br>Rivets Pack | 5BUT-<br>BOILKIT |

| Colour Notes                                                                                                                                       |
|----------------------------------------------------------------------------------------------------------------------------------------------------|
| Colour of engine, wheels, boiler and tanks LMS Crimson Lake. Smokebox, cab rod and outside frames Black. Inside frames and buffer beams Signal Red |

# Chub

# 5" Gauge

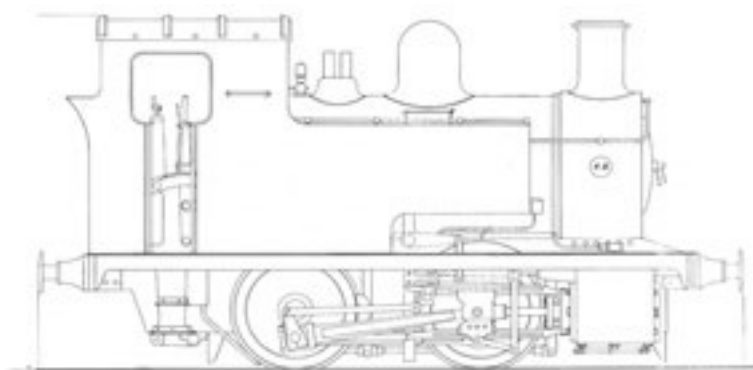

5" Gauge 0-4-0 Tank Locomotive by Charles Kennion

### Specification

Overall Length: 23 5/8"  
 Width: 9 1/2"  
 Boiler Diameter: 4 1/2"  
 Cylinder Bore: 1 1/4"  
 Stroke: 1 7/8"  
 Wheel Outside Diameter: 4 5/16"

Chub followed repeated requests for a small 5" locomotive that would be inexpensive to build but still provide good power.



|                                   |       |
|-----------------------------------|-------|
| Full Drawing Set - 12 Sheets (A1) | 15068 |
|-----------------------------------|-------|

| Item / Product / Casting                       | SKU          |
|------------------------------------------------|--------------|
| Horn Block Pair (2 Req)                        | AQ           |
| Main Axle Box Pair (2 Req)                     | AV           |
| Wheel - CI (4 Req)                             | 5CW          |
| Brake Shoe Ring - CI                           | DF2          |
| Pump Stay                                      | BA2          |
| Pump Body (2 Req)                              | BB2          |
| Pump Stand                                     | BB8          |
| Eccentric Strap (2 Req)                        | 288          |
| Hand Pump                                      | BB1          |
| Exhaust Tee                                    | BC3          |
| Cylinder Block                                 | 5BCC         |
| Steam Chest                                    | 5BSC         |
| Front Cylinder Cover                           | DS2          |
| Rear Cylinder Cover                            | DS1          |
| Valve Pair                                     | 5BV          |
| Piston Blank (2 Req)                           | 220GM        |
| <i>Piston Blank - CI (Alternative - 2 Req)</i> | <i>220CI</i> |
| Piston Gland Pair                              | 5BG          |
| Crosshead (2 Req)                              | BD1          |

| Item / Product / Casting            | SKU  |
|-------------------------------------|------|
| Buckle (2 Req)                      | 5BB  |
| Front Valve Guide Rod (2 Req)       | BB0  |
| Guide Bar Motion Bracket (2 Req)    | BA1  |
| Expansion Link Bearing Pair         | BB3  |
| Smoke Box to Boiler Connection Ring | BC1  |
| Smoke Box Front                     | BC2  |
| Door                                | CAK1 |
| Chimney                             | CAA3 |
| Dome                                | CAA1 |
| Safety Valve Base                   | CAA2 |
| Superheater End Blocks              | 70   |
| Grate                               | 5BGR |

| Additional Product Requirements |          |
|---------------------------------|----------|
| Name Plate                      | CHUNPGM  |
| Laser Cut Main Frame L/H        | GLR053LH |
| Laser Cut Main Frame R/H        | GLR053RH |
| Axle Box Spring (8 Req)         |          |
| O-Ring Set                      |          |

| Boiler Material Kit                                                                                                                                                                                                                              | SKU          |
|--------------------------------------------------------------------------------------------------------------------------------------------------------------------------------------------------------------------------------------------------|--------------|
| This kit includes all of the following materials,<br>5x Flanged Plates, Boiler Tube Material, Firebox Wrapper, Outer Wrapper Material, Firehole Ring, Longitudinal Stays, Flue Tubes, Crown Stay Material, Foundation Ring Material, Rivets Pack | 5CHU-BOILKIT |

| Colour Notes                                                                                                                                       |
|----------------------------------------------------------------------------------------------------------------------------------------------------|
| Colour of engine, wheels, boiler and tanks LMS Crimson Lake. Smokebox, cab rod and outside frames Black. Inside frames and buffer beams Signal Red |

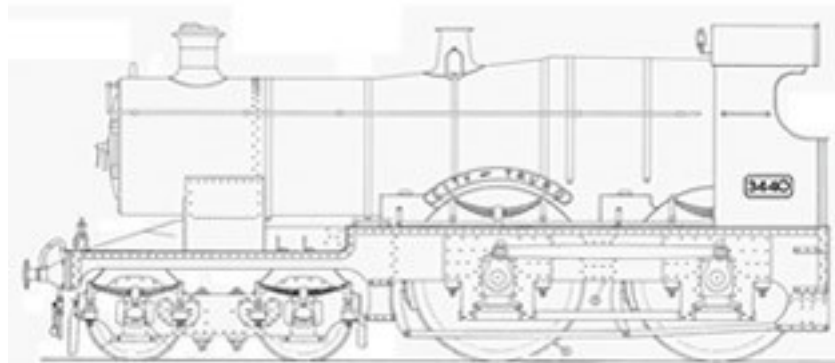

5" Gauge 4-4-0 GWR Tender

Locomotive by K. Wilson

## Specification

Overall Length (inc. Tender): 61"

Width: 8"

Boiler Diameter (Tapers to): 5 5/8"

Cylinder Bore: 1 5/8"

Stroke: 2 1/4"

Wheel Outside Diameter: 7 7/16"



Full Drawing Set - 17 Sheets (A1/L) 15101

| Item / Product / Casting          | SKU     |
|-----------------------------------|---------|
| Bogie Wheel (4 Req)               | AAM     |
| Bogie Axle Box Pair (2 Req)       | 170     |
| Dean Bogie Bracket                | 4COTBB  |
| Horn Block (4 Req)                | AE      |
| Axle Box Strip                    | AS-HALF |
| Horn Cheek (4 Req)                | 5COTHC  |
| Main Axle Box Strip               | AS      |
| Driving Wheel (4 Req)             | 5CTDW   |
| Cylinder Block                    | 5COTCGM |
| Steam Chest                       | 5COTSC  |
| Front Cylinder Cover (2 Req)      | B1FC    |
| Adams Rear Cylinder Cover (2 Req) | KM9GM   |
| Piston Blank (2 Req)              | 222GM   |
| Crosshead (2 Req)                 | BD3     |
| Gut Block for Con Rod (2 Req)     | A173    |
| Motion Plate                      | 5COTMP  |
| Eccentric Strap Pair (2 Req)      | 290     |
| Chimney                           | CAC     |
| Safety Valve Cover                | CAC2    |
| Smoke Box Door Ring               | CBA1    |
| Smoke Box Door                    | CAO1    |
| Superheater End Blocks            | 70      |
| Buffer Small (4 Req)              | 5COT    |
|                                   | BAGM    |

| Item / Product / Casting     | SKU |
|------------------------------|-----|
| Tender Horn (6 Req)          | 153 |
| Tender Axle Box Pair (3 Req) | 158 |
| Tender Wheel - CI (6 Req)    | AAL |
| Tender Brake Shoe Ring       | DF2 |
| Tender Hand Pump             | 134 |

## Alternative Casting Material Options

|                                        |          |
|----------------------------------------|----------|
| Horn Block - CI (4 Req)                | AECI     |
| Front Cylinder Cover - CI (2 Req)      | B1FCCI   |
| Adams Rear Cylinder Cover - CI (2 Req) | KM9CI    |
| Piston Blank - CI (2 Req)              | 222CI    |
| Steam Chest - CI                       | 5COTSCCI |
| Buffer Small - CI (4 Req)              | 5COTBACI |

## Alternative Casting Material Options

|                                    |         |
|------------------------------------|---------|
| Laser Cut Bogie Frame (2 Req)      | KEN501A |
| Laser Cut Main Outer Frame (2 Req) | KEN501B |
| Laser Cut Main Inner Frame (2 Req) | KEN501C |
| Laser Cut Tender Frame (2 Req)     | KEN501D |
| Buffer Spring (4 Req)              |         |



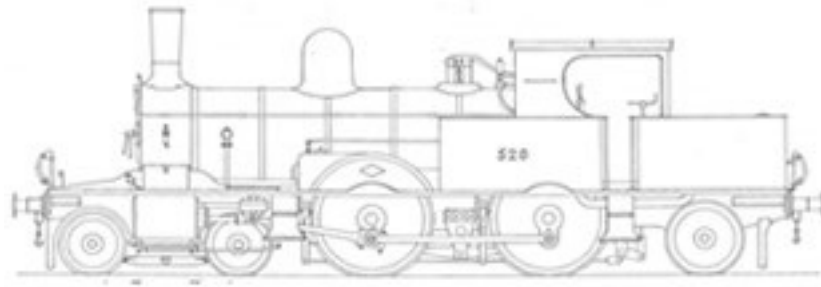

5" Gauge 4-4-2 Adams 415 Class Radial Tank Locomotive by K.S. Moonie

### Specification

|                         |         |
|-------------------------|---------|
| Overall Length:         | 81"     |
| Width:                  | 9 1/32" |
| Boiler Diameter:        | 4 1/2"  |
| Cylinder Bore:          | 1 1/2"  |
| Stroke:                 | 2 1/8"  |
| Wheel Outside Diameter: | 6 1/4"  |

These locomotives were built in the mid 1980's for the L & SWR commuter service out of Waterloo. Three of the original 7 built served for a long time as they were used on the Axminster to Lyme Regis Line.



|                                   |       |
|-----------------------------------|-------|
| Full Drawing Set - 14 Sheets (A1) | 15096 |
|-----------------------------------|-------|

| Item / Product / Casting     | SKU    |
|------------------------------|--------|
| Horn Block Pair (2 Req)      | KM16GM |
| Main Axle Box Strip          | KM17GM |
| Driving Wheel - CI (2 Req)   | KM12   |
| Coupled Wheel - CI (2 Req)   | KM13   |
| Brake Shoe Ring - CI         | KM18   |
| Bogie Wheel - CI             | KM15   |
| Bogie Axle Box Strip         | KM19GM |
| Bogie Centre                 | KM20GM |
| Bogie Equaliser Beam (2 Req) | KM4GM  |
| Trailing Axle Box Pair       | KM10GM |
| Trailing Wheel - CI (2 Req)  | KM3    |
| Cylinder Block (2 Req)       | KM6GM  |
| Steam Chest (2 Req)          | KM5GM  |
| Front Cylinder Cover (2 Req) | KM14GM |
| Rear Cylinder Cover (2 Req)  | KM9GM  |
| Valve (2 Req)                | K7     |
| Eccentric Strap (6 Req)      | KM21   |
| Smoke Box Ring               | KM22   |
| Chimney                      | KM26GM |
| Dome                         | KM25GM |

| Item / Product / Casting | SKU    |
|--------------------------|--------|
| Safety Valve Base        | KM24GM |

| Alternative Casting Material Options |        |
|--------------------------------------|--------|
| Main Horn Block Pair - CI (2 Req)    | KM16CI |
| Main Axle Box Strip - CI             | KM17CI |
| Bogie Axle Box Strip - CI            | KM19CI |
| Bogie Centre - CI                    | KM20CI |
| Bogie Equaliser Beam - CI (2 Req)    | KM4CI  |
| Trailing Axle Box Pair - CI (1 Req)  | KM10CI |
| Cylinder Block - CI (2 Req)          | KM6CI  |
| Steam Chest - CI (2 Req)             | KM5CI  |
| Front Cylinder Cover - CI (2 Req)    | KM14CI |
| Rear Cylinder Cover - CI (2 Req)     | KM9CI  |
| Dome - CI                            | KM25CI |
| Chimney - CI                         | KM26CI |

| Alternative Casting Material Options |        |
|--------------------------------------|--------|
| Laser Cut Bogie Frame (2 Req)        | GLR040 |
| Laser Cut Main Frame (2 Req)         | GLR012 |

| Boiler Material Kit                                                                                                                                                                                                                                           | SKU          |
|---------------------------------------------------------------------------------------------------------------------------------------------------------------------------------------------------------------------------------------------------------------|--------------|
| This kit includes all of the following materials,<br>5x Flanged Plates, Boiler Tube Material, Firebox Wrapper, Outer Wrapper Material, Joint Strip, Firehole Ring, Longitudinal Stays, Flue Tubes, Crown Stay Material, Foundation Ring Material, Rivets Pack | 5COM-BOILKIT |

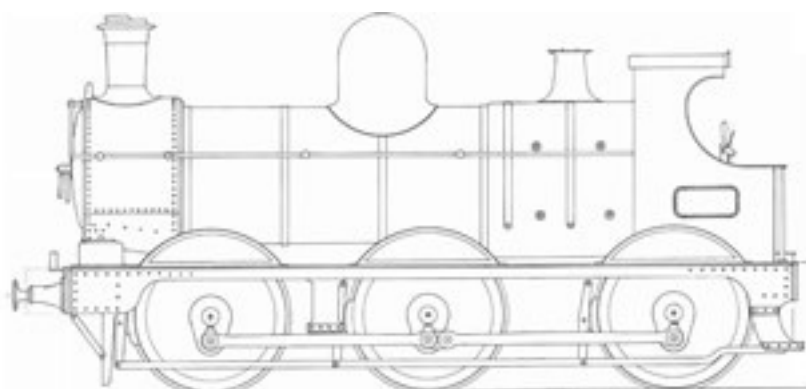

5" Gauge 0-6-0 GWR Tender

Locomotive by K. Wilson

## Specification

Overall Length (inc. Tender): 54 1/2"  
 Width: 8 1/2"  
 Boiler Diameter: 4 5/8"  
 Cylinder Bore: 1 1/2"  
 Stroke: 1 13/16"  
 Wheel Outside Diameter: 5 3/4"



|                                      |       |
|--------------------------------------|-------|
| Full Drawing Set - 11 Sheets (A1/A2) | 15100 |
|--------------------------------------|-------|

| Item / Product / Casting               | SKU   |
|----------------------------------------|-------|
| Horn Block (6 Req)                     | AM    |
| Axle Box Strip                         | AU    |
| Driving Wheel - CI (2 Req)             | 5DGDW |
| Coupled Wheel - CI (4 Req)             | 5DGCW |
| Brake Shoe Ring - CI                   | DJ2   |
| Eccentric Strap (4 Req)                | 292   |
| Cylinder Block                         | 5PYC  |
| Steam Chest                            | 5PYCS |
| Cylinder Front Cover (2 Req)           | 5PFC  |
| Cylinder Rear Cover (2 Req)            | 5PRC  |
| Valve Pair                             | 5PYV  |
| Valve Buckle Pair                      | 5PYB  |
| Piston Blank (2 Req)                   | 221GM |
| Crosshead (2 Req)                      | BD2   |
| Motion Plate                           | 5DGMP |
| Smoke Box Front Ring                   | CH2   |
| Smoke Box Rear Ring                    | CH1   |
| Smoke Box Rear Ring - Concentric (Alt) | CH1B  |
| Smoke Box Door                         | CAM2  |
| Chimney                                | CAD3  |
| Dome                                   | 5DG   |
| Safety Valve Cover                     | CW2   |
| Crosshead Pump                         | 246   |
| Axle Pump Body Live Steam Tee          | 164   |
| Superheater End Blocks                 | 69    |

| Item / Product / Casting     | SKU  |
|------------------------------|------|
| Buffer Small (4 Req)         | 5COT |
|                              | BAGM |
| Tender Horn (6 Req)          | 153  |
| Tender Axle Box Pair (3 Req) | 158  |
| Tender Wheel - CI (6 Req)    | AAL  |
| Tender Brake Shoe Ring - CI  | DF2  |
| Tender Hand Pump             | 134  |

## Alternative Casting Material Options

|                                          |                 |
|------------------------------------------|-----------------|
| <i>Horn Block - CI (6 Req)</i>           | <i>AMCI</i>     |
| <i>Axle Box Strip - CI</i>               | <i>AUCI</i>     |
| <i>Cylinder Block - CI</i>               | <i>5PYCCI</i>   |
| <i>Steam Chest - CI</i>                  | <i>5PYCSCI</i>  |
| <i>Cylinder Front Cover - CI (2 Req)</i> | <i>5PFCCI</i>   |
| <i>Cylinder Rear Cover - CI (2 Req)</i>  | <i>5PRCCI</i>   |
| <i>Piston Blank - CI (2 Req)</i>         | <i>221CI</i>    |
| <i>Buffer Small - CI (4 Req)</i>         | <i>5COTBACI</i> |

## Additional Product Requirements

|                                |         |
|--------------------------------|---------|
| Laser Cut Main Frame (2 Req)   | KEN502A |
| Laser Cut Tender Frame (2 Req) | KEN502B |
| Axle Box Spring (12 Req)       |         |
| Buffer Spring (4 Req)          |         |

## 5" Narrow Gauge 2-8-4 Pannier Tank Locomotive

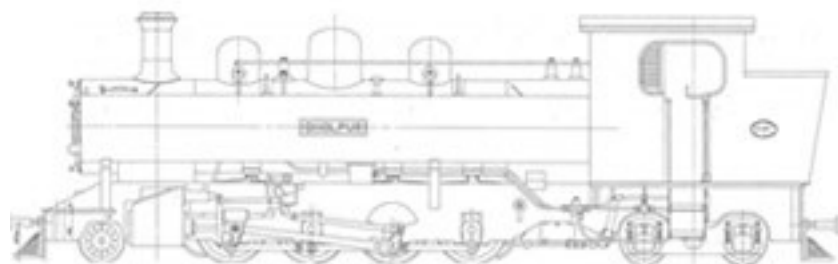

### Specification

|                         |          |
|-------------------------|----------|
| Overall Length:         | 67 9/16" |
| Width:                  | 7 5/8"   |
| Boiler Diameter:        | 6"       |
| Cylinder Bore:          | 2"       |
| Stroke:                 | 3"       |
| Wheel Outside Diameter: | 5 13/16" |



|                                   |       |
|-----------------------------------|-------|
| Full Drawing Set - 19 Sheets (A1) | 15102 |
|-----------------------------------|-------|

| Item / Product / Casting                         | SKU    |
|--------------------------------------------------|--------|
| Cylinder Block L/H - CI                          | D1     |
| Cylinder Block R/H - CI                          | D2     |
| Steam Chest Cover - CI (2 Req)                   | D3     |
| Valve Guide L/H - CI                             | D4LHCI |
| Valve Guide R/H - CI                             | D4RHCI |
| Rear Cylinder Cover - CI (2 Req)                 | D5     |
| Front Cylinder Cover - CI (2 Req)                | D6     |
| Bogie / Trailing Wheel - CI (6 Req)              | D7     |
| Driving / Coupled Wheel - CI (6 Req)             | D8     |
| Horn Block - CI (8 Req)                          | D9     |
| Front Buffer Beam Corner Bracket - CI (4 Req)    | D10    |
| Frame Stretcher Rear Bogie Mounting - CI (2 Req) | D11    |
| Leading Bogie Pivot Bracket - CI                 | D12    |
| Leading Bogie Stretcher - CI                     | D13    |
| Frame Stretcher - CI (3 Req)                     | D14    |
| Main Axle Box Strip - CI                         | D15    |
| Bogie Axle Box Strip - CI                        | D16    |
| Smoke Box Door - CI                              | D18    |
| Smoke Box Door Ring - CI                         | D19    |
| Chimney - CI                                     | D25CI  |

| Item / Product / Casting                | SKU   |
|-----------------------------------------|-------|
| Rear Bogie Horn Cheek L/H - CI (4 Req)  | D20   |
| Rear Bogie Horn Cheek R/H - CI (4 Req)  | D21   |
| Rear Bogie Frame Stretcher - CI (2 Req) | D22   |
| Leading Bogie Axle Housing - CI         | D23   |
| Regulator Dome - CI                     | D26CI |
| Sand Dome - CI                          | D27CI |
| Brake Cylinder - GM                     | D29   |
| Front Bogie Spring - Aluminium          | D34   |
| Main Spring - Aluminium (8 Req)         | D35   |
| Brake Block - CI (8 Req)                | D36   |
| Side Spring Stop L/H - CI               | D37   |
| Side Spring Stop R/H - CI               | D38   |

| Alternative Casting Material Options |       |
|--------------------------------------|-------|
| Chimney - GM                         | D25GM |
| Regulator Dome - GM                  | D26GM |
| Sand Dome - GM                       | D27GM |

| Additional Product Requirements    |         |
|------------------------------------|---------|
| Laser Cut Main Frame (2 Req)       | KEN503A |
| Laser Cut Rear Bogie Frame (2 Req) | KEN503B |



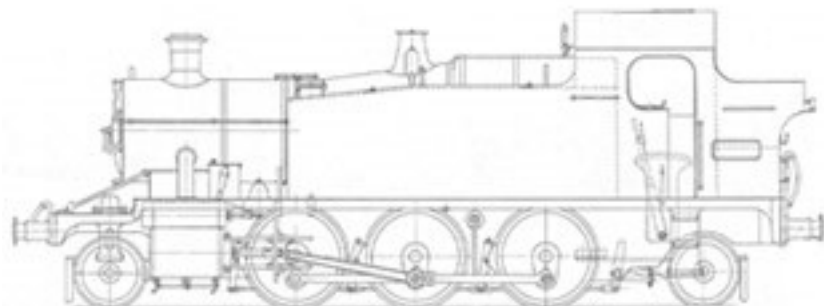

5" Gauge 2-6-2 GWR Class 4500 Tank  
Locomotive by Martin Evans

## Specification

|                              |         |
|------------------------------|---------|
| Overall Length:              | 40 1/4" |
| Width:                       | 9 5/8"  |
| Boiler Diameter (Tapers to): | 4 3/4"  |
| Cylinder Bore:               | 1 1/2"  |
| Stroke:                      | 1 1/8"  |
| Wheel Outside Diameter:      | 5 3/16" |



|                                   |       |
|-----------------------------------|-------|
| Full Drawing Set - 12 Sheets (A2) | 15069 |
|-----------------------------------|-------|

|                    |  |
|--------------------|--|
| Construction Notes |  |
|--------------------|--|

| Item / Product / Casting     | SKU      |
|------------------------------|----------|
| Horn Block (6 Req)           | AE       |
| Driving Wheel - CI (2 Req)   | 5FDW     |
| Coupled Wheel - CI (4 Req)   | 5FCW     |
| Brake Shoe Ring - CI         | D11B     |
| Axle Keep Strip              | AW1      |
| Main Axle Box Strip          | AY       |
| Bogie Wheel - CI (4 Req)     | AAH      |
| Eccentric Strap (4 Req)      | 292      |
| Pony Axle Box Strip          | AK       |
| Cylinder Block (2 Req)       | 5FC      |
| Steam Chest (2 Req)          | 5FSC     |
| Front Cylinder Cover (2 Req) | B1FC     |
| Rear Cylinder Cover (2 Req)  | B1RC     |
| Piston Blank (2 Req)         | 221GM    |
| Valve (2 Req)                | 5FV      |
| Crosshead (2 Req)            | BD3      |
| Crosshead Pump               | 248      |
| Safety Valve Cover           | CAC2     |
| Smoke Box Ring               | CAY1     |
| Saddle                       | 5FSADDLE |

| Item / Product / Casting | SKU  |
|--------------------------|------|
| Hand Pump                | 134  |
| Smoke Box Door           | CAM2 |
| Chimney                  | CAC  |
| Superheater End Blocks   | 70   |
| Grate - CI               |      |

| Alternative Casting Material Options |             |
|--------------------------------------|-------------|
| Horn Block - CI (6 Req)              | AECI        |
| Cylinder Block - CI (2 Req)          | 5FCCI       |
| Steam Chest - CI (2 Req)             | 5FSCCI      |
| Front Cylinder Cover - CI (2 Req)    | B1FCCI      |
| Rear Cylinder Cover - CI (2 Req)     | B1RCCI      |
| Piston Blank - CI (2 Req)            | 221CI       |
| Saddle - CI                          | 5FSAD-DLECI |

| Additional Product Requirements |        |
|---------------------------------|--------|
| Laser Cut Main Frame (2 Req)    | GLR019 |
| Axle Box Spring (12 Req)        |        |
| Buffer Spring (4 Req)           |        |



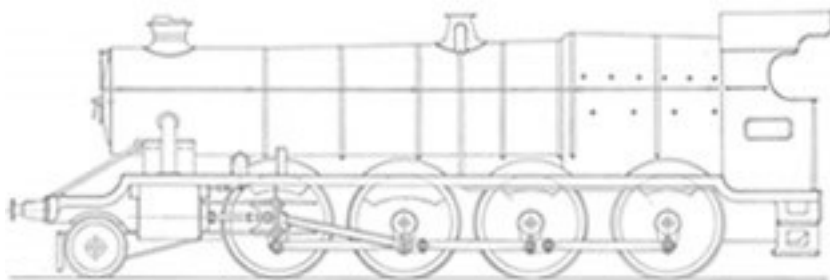

5" Gauge 2-8-0 GWR 4700 Class

Locomotive by Keith Wilson

### Specification

Overall Length (inc. Tender): 68"

Width: 9"

Boiler Diameter (Tapers to): 5 1/2"

Cylinder Bore: 1 5/8"

Stroke: 2 5/8"

Wheel Outside Diameter: 6 1/4"

Heavy mixed traffic locomotive



|                                     |       |
|-------------------------------------|-------|
| Full Drawing Set - 11 Sheets (A1/M) | 15129 |
|-------------------------------------|-------|

| Item / Product / Casting             | SKU         |
|--------------------------------------|-------------|
| Horn Block (8 Req)                   | AE          |
| Main Axle Box Pair (4 Req)           | AV          |
| Axle Box Strip                       | CE2         |
| Driving / Coupled Wheel - CI (8 Req) | 4300DW      |
| Brake Shoe Ring - CI                 | DK2         |
| Bogie Wheel - CI (2 Req)             | AAH         |
| Cylinder Block (2 Req)               | 4300CGM     |
| Front Cylinder Cover (2 Req)         | B1FC        |
| Rear Cylinder Cover (2 Req)          | DAB1GM      |
| Piston Blank (2 Req)                 | 219GM       |
| Eccentric Strap Pair (2 Req)         | 290         |
| Guide Bar Bracket (2 Req)            | 249         |
| Smoke Box Door                       | AC1         |
| Smoke Box Ring                       | CBA2        |
| Chimney                              | CAB1GM      |
| Safety Valve Cover                   | CAC2        |
| Saddle                               | 4700SAD-DLE |
| Superheater End Blocks               | 69          |
| Tender Horn (6 Req)                  | 153         |
| Tender Axle Box Pair (3 Req)         | 158         |
| Tender Wheel - CI (6 Req)            | AAL         |

| Item / Product / Casting | SKU       |
|--------------------------|-----------|
| Brake Shoe Ring - CI     | DF2       |
| Tender Hand Pump         | 134       |
| Tender Spring            | 148       |
| Tender Brake Cylinder    | 146       |
| Buffer Small (4 Req)     | 5COT-BAGM |

| <i>Alternative Casting Material Options</i> |                 |
|---------------------------------------------|-----------------|
| <i>Horn Block - CI (8 Req)</i>              | <i>AECI</i>     |
| <i>Cylinder Block - CI (2 Req)</i>          | <i>4300CCI</i>  |
| <i>Front Cylinder Cover - CI (2 Req)</i>    | <i>B1FCCI</i>   |
| <i>Rear Cylinder Cover - CI (2 Req)</i>     | <i>DAB1CI</i>   |
| <i>Piston Blank - CI (2 Req)</i>            | <i>219CI</i>    |
| <i>Saddle</i>                               | <i>4700CI</i>   |
| <i>Smoke Box Ring - CI</i>                  | <i>CBA2CI</i>   |
| <i>Buffer - Small - CI (4 Req)</i>          | <i>5COTBACI</i> |

| <b>Additional Product Requirements</b> |         |
|----------------------------------------|---------|
| Laser Cut Main Frame (2 Req)           | KEN504A |
| Laser Cut Tender Frame (2 Req)         | KEN504B |

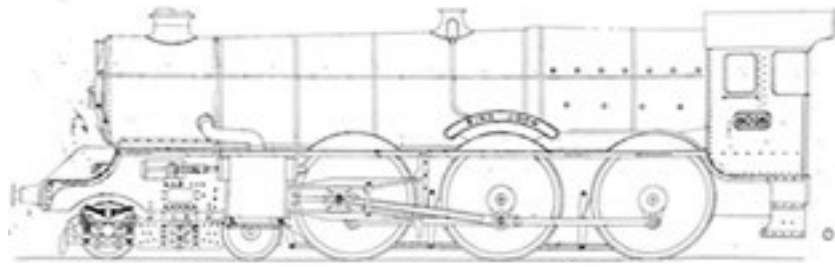

5" Gauge 4-6-0 GWR King Class Tender  
Locomotive by Keith Wilson

#### Specification

|                               |        |
|-------------------------------|--------|
| Overall Length (inc. Tender): | 72"    |
| Width:                        | 8 1/2" |
| Boiler Diameter (Tapers to):  | 6"     |
| Cylinder Bore:                | 1 3/8" |
| Stroke:                       | 2 1/4" |
| Wheel Outside Diameter:       | 7 1/4" |



This is a powerful and reliable locomotive of exhibition standards. A good looking engine that works really well. Every external rivet location was measured from enlarged photographs of the full size locomotive. The only alterations have been for ease of use and reliability.

|                                       |       |
|---------------------------------------|-------|
| Full Drawing Set - 6 Sheets (A1/XL/L) | 15143 |
|---------------------------------------|-------|

| Item / Product / Casting       | SKU      |
|--------------------------------|----------|
| Horn Block (6 Req) *           | AE *     |
| Axle Box Strip                 | AU       |
| Drawbar - CI                   | 154      |
| Driving Wheel - CI (2 Req)     | KJDW     |
| Coupled Wheel - CI (2 Req)     | KJCW     |
| Brake Shoe Ring - CI           | DQ       |
| Pump Stay                      | 151R     |
| Pump Body (2 Req)              | 140      |
| Pump Manifold                  | 136      |
| Front Bogie Horn (2 Req)       | 142L     |
| Front Bogie Axle Box Pair      | 142R     |
| Rear Bogie Horn (4 Req)        | 144L     |
| Rear Bogie Axle Box Pair       | 145      |
| Bogie Spring Yoke              | 143R     |
| Bogie Spring Casting (2 Req)   | 344      |
| Bogie Pressure Pad Pair        | 144R     |
| Bogie Guide Block              | 150      |
| Bogie Rear Stay *              | 149R *   |
| Bogie Front Stay *             | 149LGM * |
| Bogie Pin Bolster              | 151      |
| Bogie Bolster                  | 5KJBC    |
| Bogie Wheel - CI (4 Req)       | AAH      |
| Guide Bar Bracket - L/H - CI   | 152L     |
| Guide Bar Bracket - R/H - CI   | 152R     |
| Motion Plate Bracket           | 155      |
| Valve Gear Bracket             | 156      |
| Valve Rod Support              | 159R     |
| Outside Guide Bar - CI (4 Req) | 159L     |
| Inside Guide Bar - CI (4 Req)  | 236      |
| Eccentric Strap (4 Req)        | 297      |

| Item / Product / Casting             | SKU     |
|--------------------------------------|---------|
| Smoke Box Door Ring                  | CBB1 GM |
| Smoke Box Door                       | CAP     |
| Chimney                              | CAB1    |
| Safety Valve Cover                   | CAB2    |
| Buffer Large - CI (4 Req) *          | BS1 *   |
| Outside Cylinder (2 Req) *           | KJOC *  |
| Inside Cylinder *                    | 5KJIC * |
| Valve Liner (Cylinder Liner) (4 Req) | 5KJCL   |
| Front Cylinder Cover (4 Req) *       | B1FC *  |
| Rear Cylinder Cover (4 Req) *        | 5KJCC * |
| Front Cylinder Liner Cover (4 Req) * | 27 *    |
| Rear Cylinder Liner Cover (4 Req) *  | 5KJVE * |
| Tender Horn (6 Req)                  | 153     |
| Tender Axle Box Pair (3 Req)         | 158     |
| Tender Wheel - CI (6 Req)            | AAL     |
| Tender Brake Shoe Ring - CI          | DF2     |
| Tender Hand Pump                     | 134     |
| Tender Spring (6 Req)                | 148     |
| Tender Brake Cylinder                | 146     |

| Additional Product Requirements  |         |
|----------------------------------|---------|
| Laser Cut Bogie Frame (2 Req)    | KEN505A |
| Laser Cut Main Frame (2 Req)     | KEN505B |
| Laser Cut Tender Frame (2 Req)   | KEN505C |
| Etched Name Plate                | 8001    |
| Etched Number Plate              | 8002    |
| Main Axle Box Spring (12 Req)    |         |
| Bogie Compensating Spring (2Req) |         |
| Bogie Front Axle Spring (4 Req)  |         |
| Bogie Rear Axle Spring (4 Req)   |         |

Products marked with an \* are available in alternative materials, please see the price sheet for further details

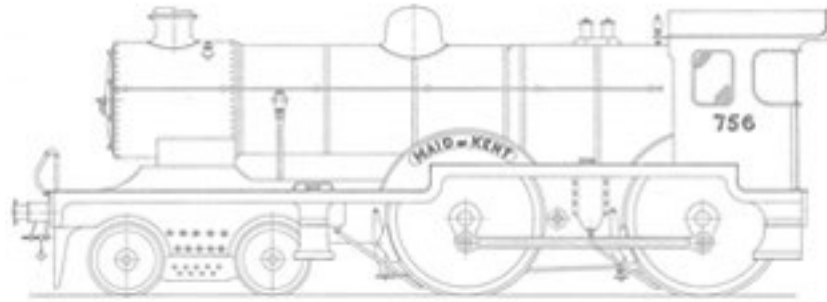

5" Gauge 4-4-0 Passenger Express  
Tender Locomotive by L.B.S.C.

### Specification

Overall Length (inc. Tender): 58 7/8"  
Width: 9"  
Boiler Diameter: 5"  
Cylinder Bore: 1 5/8"  
Stroke (Outside Cylinder): 1 1/4"  
Wheel Outside Diameter: 7 5/16"

Based on Southern Railways Maunsell L1 Class.



|                                   |       |
|-----------------------------------|-------|
| Full Drawing Set - 18 Sheets (A1) | 15145 |
|-----------------------------------|-------|

| Item / Product / Casting              | SKU     |
|---------------------------------------|---------|
| Horn Block (4 Req)                    | AE      |
| Axle Box Strip                        | AS      |
| Axle Keep Strip                       | AW1     |
| Driving Wheel - CI (2 Req)            | MOKDW   |
| Coupled Wheel - CI (2 Req)            | MOKCW   |
| Brake Shoe Ring - CI                  | DQ      |
| Frame Stay                            | 268     |
| Pump Stay / Motion Plate O/S Joy Gear | 268P    |
| Motion Bracket                        | 268R    |
| Motion Bracket                        | 268S    |
| Motion Bracket                        | 268T    |
| Motion Bracket                        | 268V    |
| Bogie Stretcher                       | 265     |
| Bogie Bolster                         | MLMX3   |
| Bogie Horn (4 Req)                    | MKMX    |
| Bogie Axle Box Strip                  | MX12    |
| Bogie Spring Pockets Strip            | 262R    |
| Bogie Wheel - CI (4 Req)              | AAH     |
| Eccentric Strap (5 Req)               | 293     |
| Front Cylinder Cover (2 Req)          | B1FC    |
| Rear Cylinder Cover (2 Req)           | CU1     |
| Valve (2 Req)                         | MKMX14H |
| Piston Blank (2 Req)                  | 221GM   |
| Guide Bar Yoke (2 Req)                | 261     |
| Crosshead (2 Req)                     | BD3     |
| Smoke Box Door                        | MOK     |
| Smoke Box Door Ring                   | CBA1    |
| Saddle                                | 266     |
| Chimney                               | CS2     |
| Safety Valve Cover                    | CS1     |

| Item / Product / Casting    | SKU   |
|-----------------------------|-------|
| Regulator Block             | MOKRB |
| Dome                        | CS3   |
| Tender Wheel - CI (6 Req)   | AAL   |
| Tender Horn (6 Req)         | 330   |
| Tender Axle Box Strip       | AX1   |
| Tender Brake Shoe Ring - CI | DF2   |
| Tender Hand Pump            | 134   |
| Tender Spring (6 Req)       | 352   |

| Cylinder Variations - Outside / Inside |        |
|----------------------------------------|--------|
| Outside Cylinder Block                 | MOKOC  |
| Outside Steam Chest                    | MOKSC  |
| Inside Cylinder Block                  | MX14A  |
| Inside Cylinder Steam Chest            | MOK14B |
| Inside Cylinder Steam Chest Cover      | 14FG   |

| Alternative Casting Material Options |        |
|--------------------------------------|--------|
| Horn Block - CI (4 Req)              | AECI   |
| Axle Box Strip - CI                  | ASCI   |
| Axle Keep Strip - CI                 | AW1CI  |
| Front Cylinder Cover - CI (2 Req)    | B1FCCI |
| Rear Cylinder Cover - CI (2 Req)     | CU1CI  |
| Piston Blank - CI (2 Req)            | 221CI  |

| Additional Product Requirements       |         |
|---------------------------------------|---------|
| Laser Cut Bogie Frame (2 Req)         | KEN506A |
| Laser Cut Main Frame (2 Req)          | KEN506B |
| Laser Cut Tender Frame (2 Req)        | KEN506C |
| Curved Name Plate                     | MOKNAME |
| Main Axle Box Spring - Ref 11 (8 Req) |         |

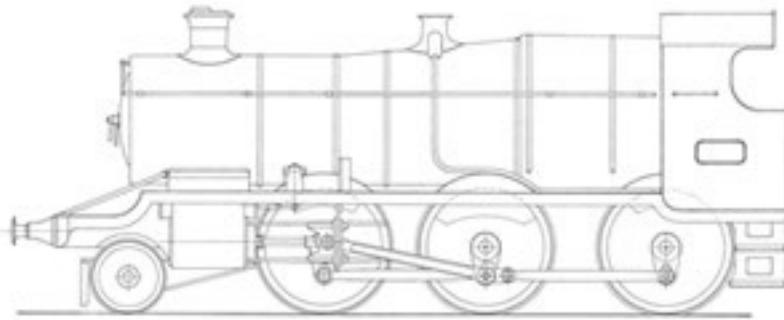

5" Gauge 2-6-0 GWR 4300 Class Tender  
Locomotive by Keith Wilson

Specification

Overall Length (inc. Tender): 60"  
Width: 9"  
Boiler Diameter (Tapers to): 5 3/8"  
Cylinder Bore: 1 5/8"  
Stroke: 2 5/8"  
Wheel Outside Diameter: 6 1/4"



Mixed traffic locomotive

|                                   |       |
|-----------------------------------|-------|
| Full Drawing Set - 17 Sheets (A2) | 15099 |
|-----------------------------------|-------|

| Item / Product / Casting             | SKU      |
|--------------------------------------|----------|
| Horn Block (6 Req)                   | AE       |
| Main Axle Box Pair (3 Req)           | AV       |
| Brake Shoe Ring - CI                 | DK2      |
| Pony Axle Box Strip                  | CE2      |
| Driving / Coupled Wheel - CI (6 Req) | 4300DW   |
| Bogie Wheel - CI (2 Req)             | AAH      |
| Cylinder Block (2 Req)               | 4300CGM  |
| Front Cylinder Cover (2 Req)         | B1FC     |
| Rear Cylinder Cover (2 Req)          | DAB1GM   |
| Piston Blank (2 Req)                 | 219GM    |
| Eccentric Strap Pair (2 Req)         | 290      |
| Guide Bar Bracket (2 Req)            | 249      |
| Smoke Box Door                       | AC1      |
| Smoke Box Ring                       | CBA2     |
| Chimney                              | CT1      |
| Safety Valve Cover                   | CAC2     |
| Saddle                               | 4300SAD- |
|                                      | DLE      |
| Tender Horn (6 Req)                  | 153      |
| Tender Wheel - CI (6 Req)            | AAL      |

| Item / Product / Casting     | SKU   |
|------------------------------|-------|
| Tender Brake Shoe Ring - CI  | DF2   |
| Tender Hand Pump             | 134   |
| Tender Axle Box Pair (3 Req) | 158   |
| Superheater End Blocks       | 69    |
| Buffer - Small (4 Req)       | 5COT- |
|                              | BAGM  |

| <i>Alternative Casting Material Options</i> |                 |
|---------------------------------------------|-----------------|
| <i>Horn Block - CI (6 Req)</i>              | <i>AECI</i>     |
| <i>Cylinder Block - CI (2 Req)</i>          | <i>4300CCI</i>  |
| <i>Front Cylinder Cover - CI (2 Req)</i>    | <i>B1FCCI</i>   |
| <i>Rear Cylinder Cover - CI (2 Req)</i>     | <i>DAB1CI</i>   |
| <i>Smoke Box Ring - CI</i>                  | <i>CBA2CI</i>   |
| <i>Piston Blank - CI (2 Req)</i>            | <i>219CI</i>    |
| <i>Buffer - Small - CI (4 Req)</i>          | <i>5COTBACI</i> |

| Additional Product Requirements |         |
|---------------------------------|---------|
| Laser Cut Main Frame (2 Req)    | KEN507A |
| Laser Cut Tender Frame (2 Req)  | KEN507B |



5" Gauge 0-4-2 LSWR A12 (Jubilee) Class  
W Adams Mixed Tender Locomotive.

### Specification

Overall Length (inc. Tender): 56 3/16"  
Width: 8 13/32"  
Boiler Diameter: 4 3/4"  
Cylinder Bore: 1 1/2"  
Stroke: 2 1/8"  
Wheel Outside Diameter: 6 11/16"

By K S Moonie, this is a beautiful model locomotive. The open cab aspect makes it easy to fire and drive, and the drawings are very neat and detailed.



|                                   |       |
|-----------------------------------|-------|
| Full Drawing Set - 17 Sheets (A1) | 15098 |
|-----------------------------------|-------|

| Item / Product / Casting                | SKU     |
|-----------------------------------------|---------|
| Adams Horn Block (4 Req)                | KM37GM  |
| Adams Main Axle Box Strip               | KM17GM  |
| LSWR A12 Class Wheel - CI (4 Req)       | KM27    |
| Brake Shoe Ring - CI                    | KM28    |
| Trailing/ Tender Wheel - CI (8 Req)     | KM30    |
| Trailing / Tender Axle Box Pair (4 Req) | KM2     |
| Cylinder Block (2 Req)                  | KM37CYL |
|                                         | GM      |
| Steam Chest (2 Req)                     | KM38SC  |
|                                         | GM      |
| Front Cylinder Cover (2 Req)            | KM14GM  |
| Rear Cylinder Cover (2 Req)             | KM9GM   |
| Piston Blank (2 Req)                    | 222GM   |
| Valve (2 Req)                           | KM39VGM |
| Regulator Gland Bush                    | KM50    |
| Guide Bar Yoke                          | KM32    |
| Weighshaft Bracket Pair                 | KM33    |
| Eccentric Strap (4 Req)                 | KM31    |
| Reverser Stand                          | KM34    |
| Smoke Box to Boiler Ring                | KM35    |
| Smoke Box Door                          | KM36    |
| Adams Chimney                           | KM26GM  |
| Adams Dome                              | KM25GM  |

| Item / Product / Casting      | SKU    |
|-------------------------------|--------|
| Safety Valve Base             | KM24GM |
| Tender Spring Casting (6 Req) | 282    |
| Tender Horn (6 Req)           | KM1    |
| Tender Brake Shoe Ring        | DF2    |

| Alternative Casting Material Options |          |
|--------------------------------------|----------|
| Adams Horn Block - CI (4 Req)        | KM37CI   |
| Adams Main Axle Box Strip - CI       | KM17CI   |
| Cylinder Block - CI (2 Req)          | KM37CYL  |
|                                      | CI       |
| Steam Chest - CI (2 Req)             | KM38SCCI |
| Front Cylinder Cover - CI (2 Req)    | KM14CI   |
| Rear Cylinder Cover - CI (2 Req)     | KM9CI    |
| Piston Blank - CI (2 Req)            | 222CI    |
| Valve - CI (2 Req)                   | KM39VCI  |
| Adams Chimney - CI                   | KM26CI   |
| Adams Dome - CI                      | KM25CI   |
| Safety Valve Base - Brass            | KM24BR   |

| Additional Product Requirements    |        |
|------------------------------------|--------|
| Laser Cut Main Inner Frame (2 Req) | GLR013 |
| Laser Cut Main Outer Frame (2 Req) | GLR014 |
| Laser Cut Tender Frame (2 Req)     | GLR015 |

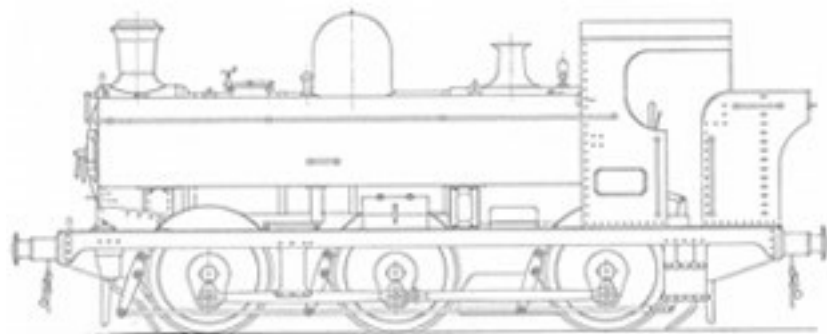

5" Gauge 0-6-0 GWR Tank Locomotive  
by L.B.S.C.

## Specification

|                         |         |
|-------------------------|---------|
| Overall Length:         | 33 1/2" |
| Width:                  | 8 1/2"  |
| Boiler Diameter:        | 5"      |
| Cylinder Bore:          | 1 1/2"  |
| Stroke:                 | 1 3/4"  |
| Wheel Outside Diameter: | 5 3/16" |



|                                  |       |
|----------------------------------|-------|
| Full Drawing Set - 6 Sheets (A1) | 15071 |
|----------------------------------|-------|

|                    |  |
|--------------------|--|
| Construction Notes |  |
|--------------------|--|

| Item / Product / Casting                       | SKU          |
|------------------------------------------------|--------------|
| Horn Block (6 Req)                             | AM           |
| Main Axle Box Strip                            | AY           |
| Frame Stay                                     | 361P         |
| Driving Wheel - CI (2 Req)                     | 5PDW         |
| Coupled Wheel - CI (4 Req)                     | 5PCW         |
| Brake Shoe Ring - CI                           | DH1          |
| Eccentric Strap (4 Req)                        | 222          |
| Cylinder Block                                 | 5PYC         |
| Steam Chest                                    | 5PYCS        |
| Front Cylinder Cover (2 Req)                   | 5PFC         |
| Rear Cylinder Cover (2 Req)                    | 5PRC         |
| Valve Pair                                     | 5PYV         |
| Buckle Pair                                    | 5PYB         |
| Piston Blank (2 Req)                           | 221GM        |
| <i>Piston Blank - CI (Alternative - 2 Req)</i> | <i>221CI</i> |
| Crosshead (2 Req)                              | BD2          |
| Motion Plate                                   | 5DGMP        |
| Smoke Box Front Ring                           | 5PYFR        |

| Item / Product / Casting        | SKU     |
|---------------------------------|---------|
| Smoke Box Rear Ring             | 5PYRR   |
| Smoke Box Door                  | CAM2    |
| Chimney                         | CAD3    |
| Dome                            | 5PYDOME |
| Safety Valve Cover              | CW2     |
| Regulator Stand                 | 125     |
| Crosshead Pump                  | 246     |
| Axle Pump Body / Live Steam Tee | 164     |
| Superheater End Blocks          | 70      |
| Pump Body                       | 134     |

| Additional Product Requirements |         |
|---------------------------------|---------|
| Name Plate                      | PANNPGM |
| Number Plate                    | PANNOGM |
| Laser Cut Main Frame (2 Req)    | GLR047  |
| Buffer Spring (4 Req)           |         |
| Axle Box Spring (12 Req)        |         |



# Peggy

# 5" Gauge

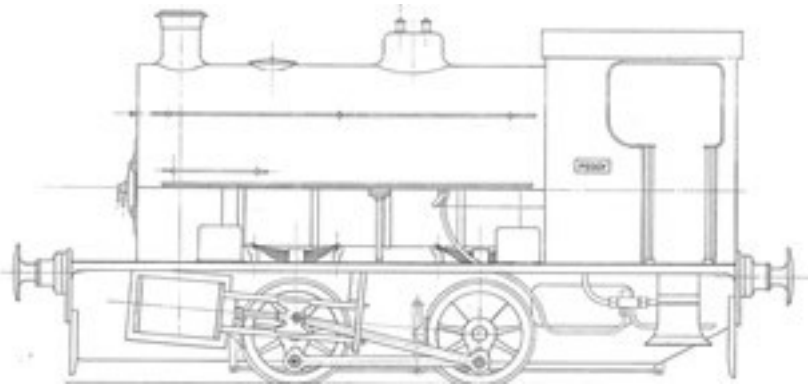

5" Gauge 0-4-0 Saddle Tank Locomotive  
by Charles Kennion

### Specification

Overall Length: 23 1/4"  
 Width: 8 1/2"  
 Boiler Diameter: 3 1/2"  
 Cylinder Bore: 1 1/8"  
 Stroke: 1 3/4"  
 Wheel Outside Diameter: 3 3/8"



|                                  |       |
|----------------------------------|-------|
| Full Drawing Set - 6 Sheets (A1) | 15072 |
|----------------------------------|-------|

| Item / Product / Casting                       | SKU          |
|------------------------------------------------|--------------|
| Horn Strip (4 Req)                             | 340          |
| Main Axle Box Strip                            | BG3          |
| Main Spring (4 Req)                            | 5P8          |
| Axle Pump Body                                 | 163          |
| Wheel - CI (4 Req)                             | 5PW          |
| Brake Shoe Ring - CI                           | DD1          |
| Cylinder Block (2 Req)                         | 5PC          |
| Steam Chest (2 Req)                            | 5PSC         |
| Front Cylinder Cover (2 Req)                   | 5MCFC        |
| Rear Cylinder Cover (2 Req)                    | 5MCRC        |
| Valve Pair                                     | 5PV          |
| Piston Blank (2 Req)                           | 220GM        |
| <i>Piston Blank - CI (Alternative - 2 Req)</i> | <i>221CI</i> |
| Eccentric Strap (4 Req)                        | 287R         |

| Item / Product / Casting | SKU  |
|--------------------------|------|
| Pump Eccentric Strap     | 285L |
| Chimney                  | CX2  |
| Dome                     | CV2  |
| Hand Pump                | 132  |
| Smoke Box Door           | CAJ2 |
| Smoke Box Front          | BF1  |
| Smoke Box to Boiler      | BF2  |
| Totem Plate              | PSBT |
| Guide Bar Bracket Pair   | BG2  |
| Motion Plate             | BG1  |

| Additional Product Requirements |        |
|---------------------------------|--------|
| Laser Cut Main Frame (2 Req)    | KEN508 |
| Axle Box Spring (4 Req)         |        |

| Boiler Material Kit                                                                                                                                                                                                                                                 | SKU              |
|---------------------------------------------------------------------------------------------------------------------------------------------------------------------------------------------------------------------------------------------------------------------|------------------|
| This kit includes all of the following materials,<br>5x Flanged Plates, Boiler Tube Material, Firebox Wrapper, Outer Wrapper Material, Joint Strip,<br>Firehole Ring, Longitudinal Stays, Flue Tubes, Crown Stay Material, Foundation Ring Material,<br>Rivets Pack | 5PEG-<br>BOILKIT |



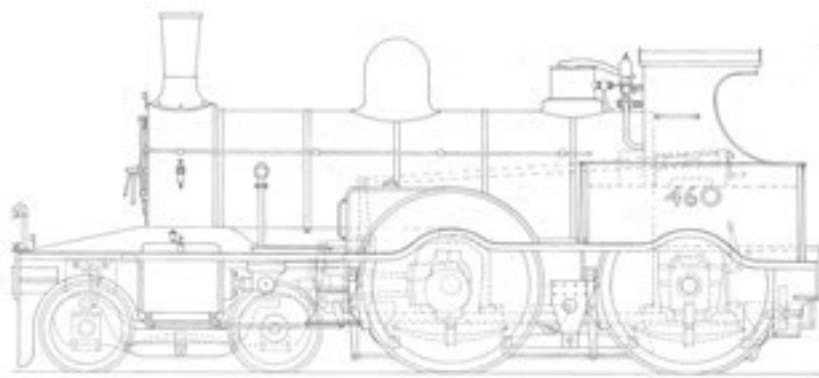

5" Gauge 4--4-0 LSWR 460 Class W  
Adams 1884 Tender Locomotive

#### Specification

|                               |         |
|-------------------------------|---------|
| Overall Length (inc. Tender): | 59"     |
| Width:                        | 8 1/2"  |
| Boiler Diameter:              | 4 1/2"  |
| Cylinder Bore:                | 1 9/16" |
| Stroke:                       | 2 1/8"  |
| Wheel Outside Diameter:       | 7 5/16" |



By K.S. Moonie based on Nelson built engines of 1882, this is a beautiful model locomotive. The open cab aspect makes it easy to fire and drive, and the drawings are very neat and detailed.

|                                  |       |
|----------------------------------|-------|
| Full Drawing Set - 15 Sheets (-) | 15097 |
|----------------------------------|-------|

| Item / Product / Casting     | SKU    |
|------------------------------|--------|
| Adams Horn Block (4 Req)     | KM37GM |
| Adams Main Axle Box Strip    | KM17GM |
| Driving Wheel - CI (2 Req)   | KM38D  |
| Coupled Wheel - CI (2 Req)   | KM38C  |
| Brake Shoe Ring - CI         | KM43   |
| Bogie Wheel - CI (4 Req)     | KM39   |
| Bogie Equaliser Beam (2 Req) | KM4GM  |
| Adams Bogie Centre           | KM20GM |
| Adams Bogie Axle Box Strip   | KM19GM |
| Reverser Stand               | KM42   |
| Eccentric Strap (6 Req)      | KM21   |
| Cylinder Block (2 Req)       | KM40GM |
| Front Cylinder Cover (2 Req) | KM14GM |
| Rear Cylinder Cover (2 Req)  | KM9GM  |
| Piston Blank (2 Req)         | 222GM  |
| Smoke Box Plate (2 Req)      | KM41   |
| Safety Valve Base            | KM24GM |
| Adams Dome                   | KM25GM |
| Adams Smoke Box Door         | KM23   |
| Adams Chimney                | KM26GM |

| Item / Product / Casting           | SKU  |
|------------------------------------|------|
| Tender Wheel - CI (6 Req)          | KM30 |
| Tender Brake Shoe Ring - CI        | DF2  |
| Tender Horn (6 Req)                | KM1  |
| Tender Cast Springs (6 Req)        | 282  |
| Adams Tender Axle Box Pair (3 Req) | KM2  |

#### Alternative Casting Material Options

|                                   |        |
|-----------------------------------|--------|
| Adams Horn Block - CI (4 Req)     | KM37CI |
| Adams Main Axle Box Strip - CI    | KM17CI |
| Bogie Equaliser Beam - CI (2 Req) | KM4CI  |
| Cylinder Block - CI (2 Req)       | KM40CI |
| Front Cylinder Cover - CI (2 Req) | KM14CI |
| Rear Cylinder Cover - CI (2 Req)  | KM9CI  |
| Piston Blank - CI (2 Req)         | 222CI  |
| Adams Dome - CI                   | KM25CI |
| Adams Chimney - CI                | KM26CI |

#### Additional Product Requirements

|                                |         |
|--------------------------------|---------|
| Laser Cut Bogie Frames (2 Req) | KEN006A |
| Laser Cut Main Frame (2 Req)   | GLR006  |
| Laser Cut Tender Frame (2 Req) | GLR007  |



# Simplex

# 5" Gauge

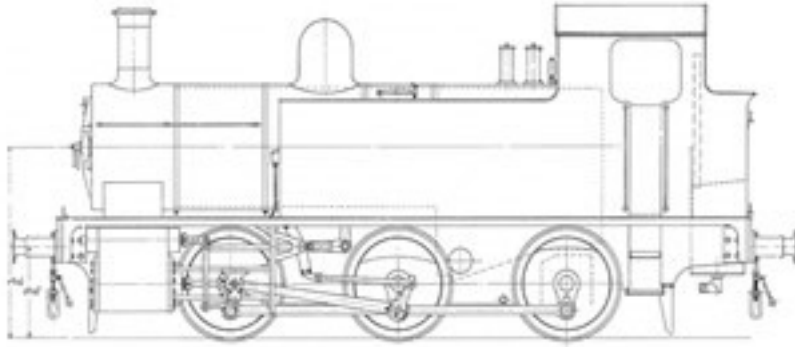

5" Gauge 0-6-0 Freelance Tank  
Locomotive by Martin Evans

### Specification

|                         |          |
|-------------------------|----------|
| Overall Length:         | 33 1/2"  |
| Width:                  | 9 3/4"   |
| Boiler Diameter:        | 4 3/4"   |
| Cylinder Bore:          | 1 1/2"   |
| Stroke:                 | 2 1/8"   |
| Wheel Outside Diameter: | 4 11/16" |



|                                  |       |
|----------------------------------|-------|
| Full Drawing Set - 7 Sheets (A1) | 15070 |
|----------------------------------|-------|

| Item / Product / Casting     | SKU     |
|------------------------------|---------|
| Main Horn Block Pair (3 Req) | 5SH     |
| Axle Box Strip               | AT      |
| Driving Wheel - CI (2 Req)   | SDW     |
| Simplex Wheel - CI (4 Req)   | SCW     |
| Brake Shoe Ring - CI         | DG1     |
| Pump Eccentric Strap         | 301     |
| Hand Pump                    | 134     |
| Cylinder Block (2 Req)       | 5SC     |
| Steam Chest (2 Req)          | 5SSC    |
| Front Cylinder Cover (2 Req) | B1FC    |
| Rear Cylinder Cover (2 Req)  | CU1     |
| Piston Blank (2 Req)         | 221GM   |
| Axle Box Strip               | AS-HALF |
| Axle Pump (Later Version)    | 300R    |
| Smoke Box Connecting Ring    | CAW1    |
| Smoke Box Door Ring          | CAY2    |

| Item / Product / Casting | SKU      |
|--------------------------|----------|
| Smoke Box Door           | CAM2     |
| Chimney                  | CQ1      |
| Dome                     | CJ2      |
| Saddle                   | 5SSADDLE |
| Rear Frame Stretcher     | 5SSR     |

| Alternative Casting Material Options |        |
|--------------------------------------|--------|
| Horn Block Pair - CI (3 Req)         | 5SHCI  |
| Cylinder Block - CI (2 Req)          | 5SCCI  |
| Steam Chest - CI (2 Req)             | 5SSCCI |
| Front Cylinder Cover - CI (2 Req)    | B1FCCI |
| Piston Blank - CI (2 Req)            | 221CI  |

| Additional Product Requirements |        |
|---------------------------------|--------|
| Laser Cut Main Frame (2 Req)    | GLR048 |
| Axle Box Spring (12 Req)        |        |



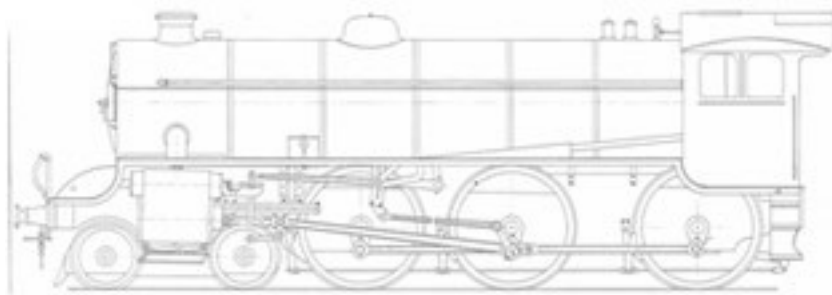

5" Gauge 4-6-0 LNER B1 Tender

Locomotive by Martin Evans

## Specification

Overall Length (inc. Tender): 65 1/2"  
 Width: 9"  
 Boiler Diameter: 6"  
 Cylinder Bore: 1 11/16"  
 Stroke: 2 1/4"  
 Wheel Outside Diameter: 6 9/16"



|                                   |       |
|-----------------------------------|-------|
| Full Drawing Set - 12 Sheets (A1) | 15073 |
|-----------------------------------|-------|

| Item / Product / Casting        | SKU     |
|---------------------------------|---------|
| Main Horn Block (6 Req)         | AE      |
| Main Axle Box Strip             | AY      |
| Driving Wheel - CI (2 Req)      | 5SBDW   |
| Coupled Wheel - CI (4 Req)      | 5SBCW   |
| Brake Shoe Ring - CI            | DK2     |
| Main Stretcher - CI             | 5SBMS   |
| Frame Stretcher - CI (2 Req)    | 5SBFS   |
| Brake Stretcher                 | 5SBBS   |
| Bogie Horn (4 Req)              | 328     |
| Bogie Axle Box Strip            | AK      |
| Bogie Centre                    | 5SBBB   |
| Bogie Spring Beams Pair (2 Req) | 5SBBSB  |
| Bogie Wheel - CI (4 Req)        | AAH     |
| Cylinder Block (2 Req)          | 5SBCGM  |
| Front Cylinder Cover (2 Req)    | B1FC    |
| Rear Cylinder Cover (2 Req)     | B1RC    |
| Piston Blank                    | 222GM   |
| Smoke Box Door                  | AC1     |
| Smoke Box Door Ring             | CBB1 GM |
| Saddle - CI                     | 5SBS    |
| Dome                            | CR1     |
| Chimney                         | CR2     |
| Superheater End Blocks          | 70      |
| Tender Horn (6 Req)             | 329     |

| Item / Product / Casting      | SKU |
|-------------------------------|-----|
| Tender Axle Box Strip         | AX1 |
| Tender Spring Casting (6 Req) | 354 |
| Tender Wheel - CI (6 Req)     | AAL |
| Tender Brake Shoe Ring - CI   | DF2 |

## Alternative Casting Material Options

|                                   |         |
|-----------------------------------|---------|
| Horn Block - CI (6 Req)           | AECI    |
| Cylinder Block - CI (2 Req)       | 5SBC    |
| Front Cylinder Cover - CI (2 Req) | B1FCCI  |
| Rear Cylinder Cover - CI (2 Req)  | B1RCCI  |
| Smoke Box Door Ring - CI          | CBB1 CI |
| Piston Blank - CI (2 Req)         | 222CI   |
| Saddle                            | 5SBSGM  |

## Additional Product Requirements

|                                   |        |
|-----------------------------------|--------|
| Laser Cut Bogie Frame (2 Req)     | GLR054 |
| Laser Cut Main Frame (2 Req)      | GLR023 |
| Laser Cut Tender Frame (2 Req)    | GLR055 |
| Axle Box Spring (12 Req)          |        |
| Drag Hook Spring (2 Req)          |        |
| Buffer Spring (4 Req)             |        |
| Bogie Axle Box Spring (8 Req)     |        |
| Bogie Compensating Spring (2 Req) |        |
| Tender Coil Spring (6 Req)        |        |



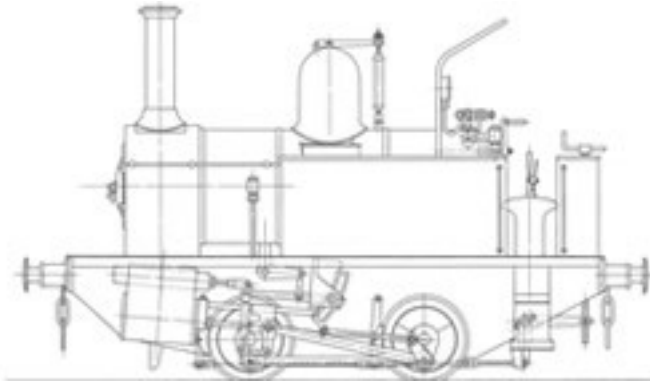

5" Gauge 0-4-0 Dock Shunting Tank  
Locomotive by Charles Kennion

#### Specification

Overall Length: 21 3/4"  
Width: 9"  
Boiler Diameter: 4"  
Cylinder Bore: 1"  
Stroke: 1 1/2"  
Wheel Outside Diameter: 3 1/8"



|                                  |       |
|----------------------------------|-------|
| Full Drawing Set - 7 Sheets (A1) | 15066 |
|----------------------------------|-------|

| Item / Product / Casting                       | SKU          |
|------------------------------------------------|--------------|
| Horn Block Pair (2 Req)                        | CD1          |
| Main Axle Box Strip                            | CE1          |
| Wheel - CI (4 Req)                             | 5TDW         |
| Brake Shoe Ring - CI                           | DC2          |
| Pump Stay                                      | 243L         |
| Axle Pump Body                                 | 117T         |
| Pump Eccentric Strap                           | 291          |
| Cylinder Block (2 Req)                         | 5TC          |
| Cylinder Steam Chest                           | 5TSC         |
| Front Cylinder Cover                           | 189          |
| Rear Cylinder Cover                            | 202          |
| Valve Pair                                     | 5TV          |
| Piston Blank (2 Req)                           | 218GM        |
| <i>Piston Blank - CI (Alternative - 2 Req)</i> | <i>218CI</i> |
| Exhaust Tee                                    | 242          |
| Steam Tee Pipe Collector                       | 247          |

| Item / Product / Casting      | SKU  |
|-------------------------------|------|
| Guide Bar Bracket - L/H       | 244L |
| Guide Bar Bracket - R/H       | 244R |
| Inner Guide Bar Bracket - L/H | 245L |
| Inner Guide Bar Bracket - R/H | 245R |
| Smoke Box Door                | CAJ2 |
| Smoke Box Front               | CH3  |
| Chimney                       | CP1  |
| Dome                          | CAA4 |

| Additional Product Requirements |        |
|---------------------------------|--------|
| Laser Cut Main Frame (2 Req)    | KEN043 |
| Axle Box Spring (8 Req)         |        |
| Drag Hook Spring (2 Req)        |        |
| Buffer Spring (4 Req)           |        |

| Boiler Material Kit                                                                                                                                                                                                         | SKU               |
|-----------------------------------------------------------------------------------------------------------------------------------------------------------------------------------------------------------------------------|-------------------|
| This kit includes all of the following materials,<br>5x Flanged Plates, Boiler Tube Material, Firebox Wrapper, Firehole Ring, Longitudinal Stays,<br>Flue Tubes, Crown Stay Material, Foundation Ring Material, Rivets Pack | 5TICH-<br>BOILKIT |

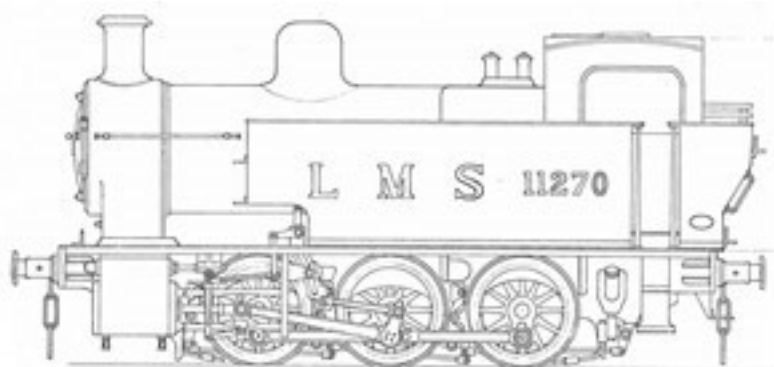

5" Gauge 0-6-0 LMS Class 2F Tank  
Locomotive by J. Austin Walton

## Specification

|                         |         |
|-------------------------|---------|
| Overall Length:         | 27 1/4" |
| Width:                  | 9"      |
| Boiler Diameter:        | 4 5/8"  |
| Cylinder Bore:          | 1 3/8"  |
| Stroke:                 | 1 7/8"  |
| Wheel Outside Diameter: | 4 3/16" |



|                                   |       |
|-----------------------------------|-------|
| Full Drawing Set - 38 Sheets (A1) | 15160 |
|-----------------------------------|-------|

| Item / Product / Casting           | SKU    |
|------------------------------------|--------|
| Trailing Horn Cheek - R/H          | 339R   |
| Trailing Horn Cheek - L/H          | 339L   |
| Leading & Driving Horn Cheek - L/H | 338L   |
| Leading & Driving Horn Cheek - R/H | 338R   |
| Axle Box Pair (3 Req)              | TSA    |
| Wheel - CI (6 Req)                 | 5TSW   |
| Brake Shoe Ring - CI               | TWS    |
| Pump Yoke                          | 206    |
| Pump Body (2 Req)                  | 207    |
| Cylinder (2 Req)                   | 5TSCYL |
| Steam Chest (2 Req)                | 5TSS   |
| Equaliser Beam                     | 205    |
| Front Cylinder Cover (2 Req)       | 203    |
| Rear Cylinder Cover (2 Req)        | 204    |

| Item / Product / Casting    | SKU  |
|-----------------------------|------|
| Guide Bar Bracket (2 Req)   | 208  |
| Weigh Shaft Bearing (2 Req) | 209  |
| Smoke Box Connecting Ring   | CAW2 |
| Smoke Box Door Ring         | CAZ2 |
| Smoke Box Door              | CAN2 |
| Chimney                     | CAD1 |
| Dome                        | CAD2 |
| Valve Guide Bracket - L/H   | 210  |
| Valve Guide Bracket - R/H   | 211  |

| Additional Product Requirements |        |
|---------------------------------|--------|
| Laser Cut Main Frame (2 Req)    | GLR044 |



# GWR 1366

# 7 1/4" Gauge

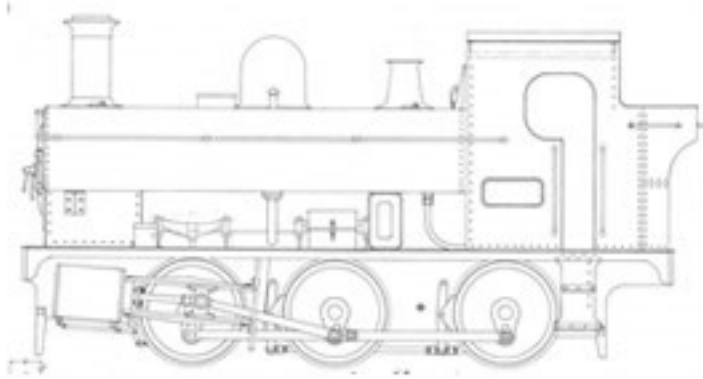

7 1/4" Gauge 0-6-0 GWR Pannier Tank  
Locomotive by Keith Wilson

### Specification

Overall Length: 36"  
 Width: 12 3/8"  
 Boiler Diameter: 6"  
 Cylinder Bore: 1 3/4"  
 Stroke: 2 1/2"  
 Wheel Outside Diameter: 5 7/8"

This is a superb locomotive which can be 'managed' in 7 1/4" scale.



|                                   |       |
|-----------------------------------|-------|
| Full Drawing Set - 10 Sheets (A1) | 15104 |
|-----------------------------------|-------|

| Item / Product / Casting                     | SKU    |
|----------------------------------------------|--------|
| Horn Block - CI (Set of 3)                   | AR     |
| Main Axle box Strip                          | AAA    |
| Driving Wheel - CI (2 Req)                   | 1366DW |
| Coupled Wheel - CI (4 Req)                   | 1366CW |
| Brake Shoe Ring - CI                         | DJ2    |
| Pump Stay                                    | 233GM  |
| Pump Body                                    | 140    |
| Eccentric Strap (5 Req)                      | 297    |
| Frame Stay                                   | 233GM  |
| Cylinder - CI (2 Req)                        | 1366CI |
| Steam Chest - CI (2 Req)                     | 1366SC |
| Rear Cover - CI (2 Req)                      | DAC1   |
| Front Cover - CI (2 Req)                     | DZ2    |
| Piston Blank - CI (2 Req)                    | 222CI  |
| <i>Piston Blank (GM Alternative - 2 Req)</i> | 222GM  |
| Valve Pair                                   | 7GWV   |
| Buckle                                       | 7GWB   |
| Guide Bar Bracket L/H                        | 235GM  |
| Guide Bar Bracket R/H                        | 234GM  |
| Guide Bar - CI (4 Req)                       | 236    |
| Crosshead (2 Req)                            | BD4    |

| Item / Product / Casting   | SKU    |
|----------------------------|--------|
| Cylinder End Block (2 Req) | 239    |
| Live Steam End Pair        | 238    |
| Foundation Plate           | A11366 |
| Smoke Box Door             | CAP    |
| Smoke Box Ring             | CBB2GM |
| Chimney                    | CU1GM  |
| Safety Valve Cover         | CV1    |
| Dome                       | CAR2   |
| Hand Pump                  | 134    |
| Cast Spring (4 Req)        | 282    |
| Buffer - CI (4 Req)        | BS1    |

| Additional Product Requirements |         |
|---------------------------------|---------|
| Laser Cut Main Frame L/H        | KEN701L |
| Laser Cut Main Frame R/H        | KEN701R |
| Etched Plates (Black)           | LP14    |
| 1366 Cast Number Plate          | 1366NP  |
| Axle Box Spring (12 Req)        |         |
| Drag Hook Spring (2 Req)        |         |
| Buffer Spring (4 Req)           |         |



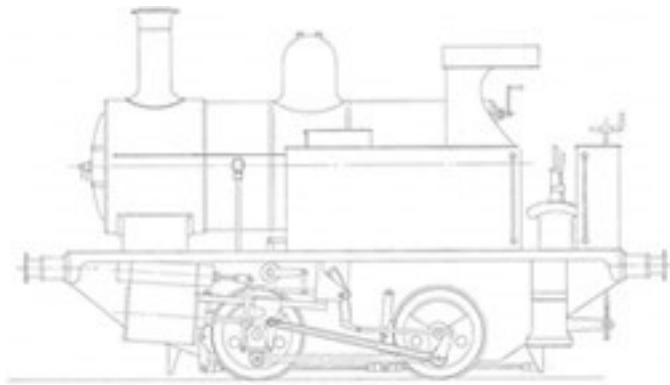

7 1/4" Gauge 0-4-0 Dock Shunting Tank  
Locomotive by Charles Kennion

## Specification

|                         |         |
|-------------------------|---------|
| Overall Length:         | 29 5/8" |
| Width:                  | 12 3/4" |
| Boiler Diameter:        | 6"      |
| Cylinder Bore:          | 1 3/8"  |
| Stroke:                 | 2 1/4"  |
| Wheel Outside Diameter: | 4 1/2"  |



|                                   |       |
|-----------------------------------|-------|
| Full Drawing Set - 11 Sheets (A1) | 15103 |
|-----------------------------------|-------|

| Item / Product / Casting | SKU     |
|--------------------------|---------|
| Horn Block (4 Req)       | AE      |
| Main Axle Box Strip      | AS      |
| Wheel - Cast Iron        | 7TDW    |
| Brake Shoe Ring - CI     | DF2     |
| Pump Stay                | 226L    |
| Axle Pump Body           | 227L    |
| Pump Eccentric Strap     | 295     |
| Cylinder (2 Req)         | 7TC     |
| Steam Chest (2 Req)      | 7TSC    |
| Rear Cover (2 Req)       | DV2     |
| Front Cover (2 Req)      | DV1     |
| Piston Blank (2 Req)     | 221GM   |
| Valve Pair               | 7TV     |
| Exhaust Tee              | 242     |
| Gear Frame L/H           | 228     |
| Gear Frame R/H           | 229     |
| Link Bearing L/H         | 230LH   |
| Link Bearing R/H         | 230RH   |
| Hand Pump                | 7THP    |
| Smoke Box Door           | CAP     |
| Smoke Box Ring           | CBB1 GM |

| Item / Product / Casting  | SKU |
|---------------------------|-----|
| Chimney                   | CJ1 |
| Dome                      | CJ2 |
| Superheater End Blocks    | 69  |
| Superheater Header & Bush | 72  |

## Alternative Casting Material Options

|                           |         |
|---------------------------|---------|
| Cylinder - CI (2 Req)     | 7TCCI   |
| Steam Chest - CI (2 Req)  | 7TSCCI  |
| Rear Cover - CI (2 Req)   | DV2CI   |
| Front Cover - CI (2 Req)  | DV1CI   |
| Piston Blank - CI (2 Req) | 221CI   |
| Horn Blocks - CI (4 Req)  | AECI    |
| Smoke Box Door Ring - CI  | CBB1 CI |

## Additional Product Requirements

|                              |        |
|------------------------------|--------|
| Laser Cut Main Frame (2 Req) | KEN702 |
| Etched Name Plates           | LP21   |
| Axle Box Spring (8 Req)      |        |
| Drag Hook Spring (2 Req)     |        |
| Buffer Spring (4 Req)        |        |



# Vertical Boiler

Stationary

This is our well known 'GLR Kennions' vertical boiler as written up in the March 1997 edition of the Model Engineer. Originally designed and sold by the Kennion Brothers in the 1950's  
Can be fired using Coal or Gas.



### Specification

|                           |         |
|---------------------------|---------|
| Boiler Tube Diameter:     | 4"      |
| Boiler Tube Length:       | 8 1/2"  |
| Total Height Inc Chimney: | 13 1/2" |
| Design Pressure:          | 80psi   |

| Drawings / Notes   | SKU   |
|--------------------|-------|
| Drawing            | 15107 |
| Construction Notes |       |

| Item / Product / Casting | SKU   |
|--------------------------|-------|
| Boiler Top Casting       | 109   |
| Mahogany Wood Strip      | 15108 |
| Pre Flanged Plates       |       |

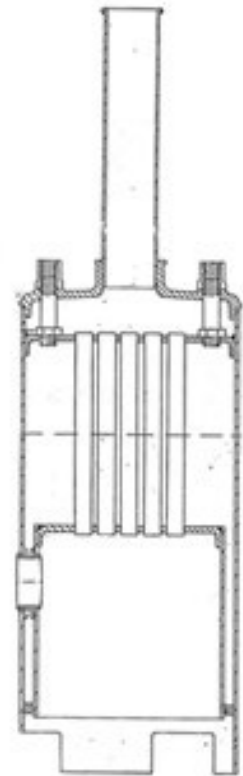

| Build Kits                                                                                                                                                                                                                                                                                                                                 | SKU              |
|--------------------------------------------------------------------------------------------------------------------------------------------------------------------------------------------------------------------------------------------------------------------------------------------------------------------------------------------|------------------|
| <b>Full Material, Lagging and Fittings Kit</b><br>This kit is supplied with all the material required to build the boiler, the external lagging items with all the required steam fitting and is also supplied with the drawings and constructions notes.                                                                                  | GLRBOIL-BUILDKIT |
| <b>Material and Drawings Kit</b><br>This kit is supplied with all the material required to build the boiler, this kit is also supplied with the drawings and construction notes                                                                                                                                                            | GLRBOIL-MATKIT   |
| <b>Boiler Lagging Kit</b><br>This kit is supplied with the lagging materials required to finish the exterior work on the boiler. Included in the kit is; 56 x Mahogany Wood Strips, 1mm Thick Lagging and Brass Banding which includes the fixing screws, nuts and washers.                                                                | GLRBOIL-LAGKIT   |
| <b>Boiler Lagging and Fittings Kit</b><br>This kit is supplied with the boiler lagging kit as above but also includes all the required steam fittings to complete the boiler.<br>Included in the kit is; Pressure Gauge, Blower Manifold Steam Valve, Blowdown Valve, Check Valve, Safety Valve, Water Gauge and the lagging kit as above. | GLRBOIL-FIXKIT   |

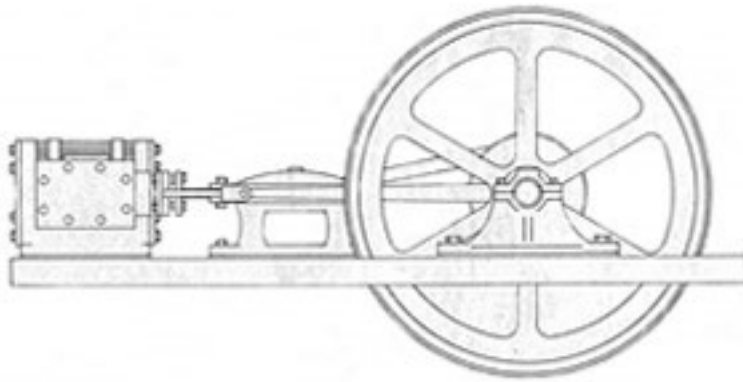

Tina Horizontal Mill Engine - Original Kennions design c1950's

**Specification**

|                    |        |
|--------------------|--------|
| Bore               | 1"     |
| Stroke             | 1 1/2" |
| Base Length        | 12"    |
| Fly Wheel Diameter | 6"     |



A very popular Kennions design Horizontal Mill Engine, this will run very nicely with our 4" diameter vertical boiler (see page 59).

|                                  |       |
|----------------------------------|-------|
| Full Drawing Set - 2 Sheets (A1) | 15105 |
|----------------------------------|-------|

|                    |       |
|--------------------|-------|
| Construction Notes | 15122 |
|--------------------|-------|

| Item / Product / Casting | SKU      |
|--------------------------|----------|
| Aluminium Base Plate     | ALBASE   |
| Cast Iron Fly Wheel      | MEFLWH   |
| Steel Crank Disc         | TINADISC |
| Cylinder Block           | 102      |
| Steam Chest              | 106L     |
| Steam Chest Cover        | 106C     |
| Cylinder Front Cover     | 107R     |
| Cylinder Rear Cover      | 107L     |

| Item / Product / Casting  | SKU   |
|---------------------------|-------|
| Valve                     | 3TV   |
| Piston Blank              | 218GM |
| Pump Body                 | 108L  |
| Eccentric Strap (2 Req)   | 283L  |
| Main Bearing (2 Req)      | 104L  |
| Main Bearing Caps (Pair)  | 104R  |
| Guide Bar Bracket (2 Req) | 103L  |
| Guide Bar Cover (2 Req)   | 103R  |

| Drawings and Casting Set                                                                                                                                                                                                                                  | SKU     |
|-----------------------------------------------------------------------------------------------------------------------------------------------------------------------------------------------------------------------------------------------------------|---------|
| Casting and Drawings Set<br>Supplied with full drawings, construction notes, crank disc billet and all required unmachined castings<br>* Base plate supplied in Aluminium and Flywheel supplied in Cast Iron all other castings are supplied in Gun Metal | TINASET |

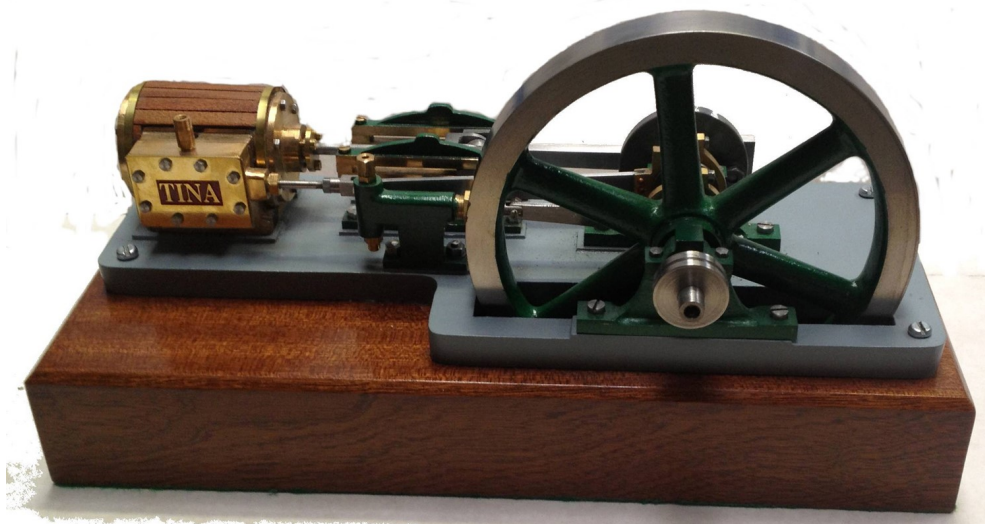

# Rachel - Wall Mounted Engine

**Stationary**

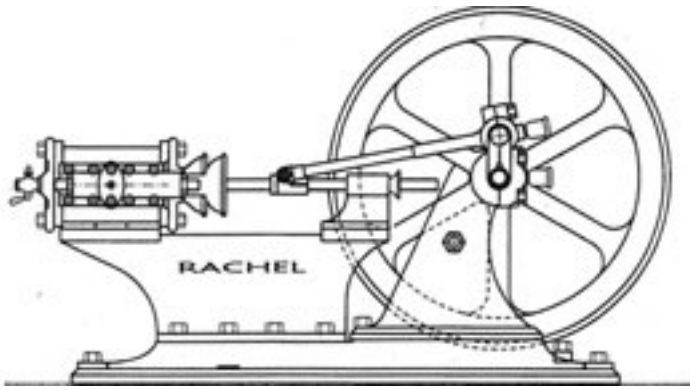

Rachel Wall Mounted Engine -  
Originated by Otto Lilienthal - Germany

**Specification**

Bore 22mm  
Stroke 40mm  
Fly Wheel Diameter 16.4mm

A very unusual Wall Mounted Engine, originated by Otto Lilienthal - Germany. Built in the scale of 1:5 reflecting the fact that all the original was quite a small engine. Most stationery models are built to a scale no larger than 1:12. Designed and drawn by W. Schneeberger.



|                                  |       |
|----------------------------------|-------|
| Full Drawing Set - 7 Sheets (A2) | 15190 |
|----------------------------------|-------|

|                    |       |
|--------------------|-------|
| Construction Notes | 15192 |
|--------------------|-------|

| Item / Product / Casting           | SKU |
|------------------------------------|-----|
| Distance Bar - CI (2 Req)          | WE2 |
| Mounting Bracket - CI              | WE9 |
| Crank Bearing Support - CI (2 Req) | WE1 |
| Cylinder Block                     | WE4 |
| Steam Chest                        | WE5 |

| Item / Product / Casting | SKU |
|--------------------------|-----|
| Steam Chest Cover        | WE6 |
| Eccentric Strap (2 Req)  | WE8 |
| Flywheel - CI            | WE3 |
| Con Rod Eccentric Strap  | WE7 |

| Drawings and Casting Set                                                                                | SKU    |
|---------------------------------------------------------------------------------------------------------|--------|
| Casting and Drawings Set                                                                                |        |
| Supplied with full drawings, construction notes, crank disc billet and all required unmachined castings | RACSET |

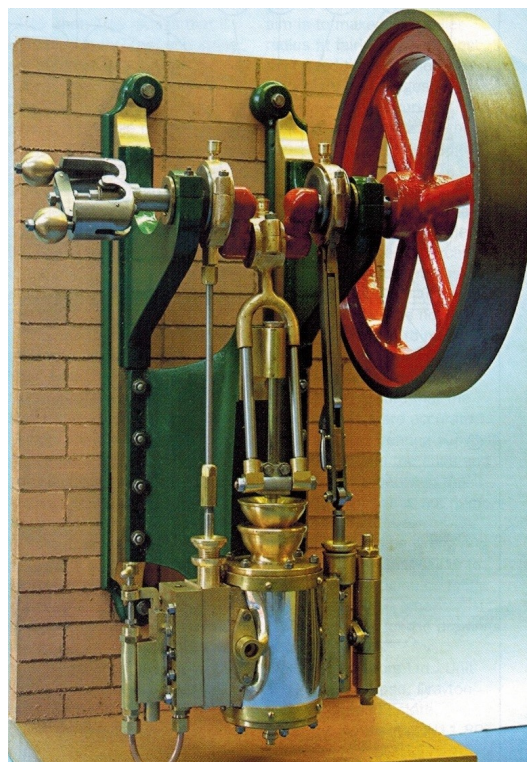

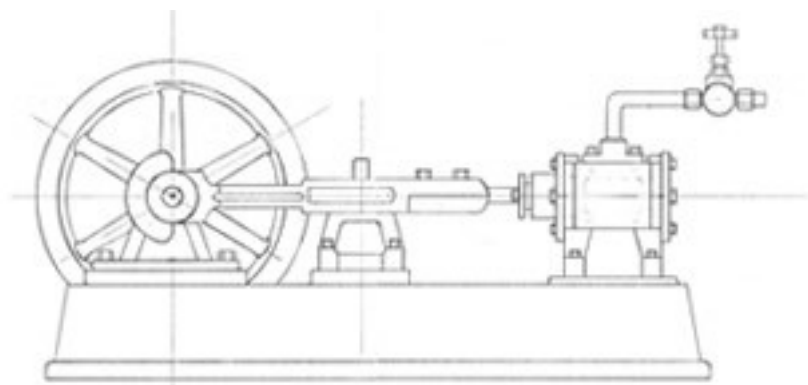

Roxanne is a compact Horizontal Mill Engine Developed by EKP Supplies

**Specification**

|                   |        |
|-------------------|--------|
| Bore              | 9/16"  |
| Stroke            | 5/8"   |
| Base Length       | 7 5/8" |
| Flywheel Diameter | 3 3/4" |



Developed by EKP Supplies and Launched in 2024. Roxanne is a very nice compact desktop Horizontal Mill Engine and is the perfect engine for the starting out model engineer.

|                                  |         |
|----------------------------------|---------|
| Full Drawing Set - 3 Sheets (A1) | RX-DRAW |
|----------------------------------|---------|

| Item / Product / Casting | SKU     |
|--------------------------|---------|
| Base Plate - AL          | RX-BP   |
| Flywheel - CI            | RX-FWHL |
| Cylinder Block           | RX-01   |
| Push Rod                 | RX-02   |
| Cylinder Block Cover     | RX-03   |
| Eccentric Strap          | RX-04   |
| Cylinder Valve           | RX-05   |
| Support Bracket          | RX-06   |

| Item / Product / Casting | SKU   |
|--------------------------|-------|
| Metal Bracket            | RX-07 |
| Bearing Support (2 Req)  | RX-08 |

| <i>Alternative Options</i> |                   |
|----------------------------|-------------------|
| <i>Base Plate</i>          | <i>RX-BP-GM</i>   |
| <i>Base Plate - CI</i>     | <i>RX-BP-CI</i>   |
| <i>Flywheel</i>            | <i>RX-FWHL-GM</i> |

| Drawings and Casting Set                                                                                                                                                                                                                                                     | SKU        |
|------------------------------------------------------------------------------------------------------------------------------------------------------------------------------------------------------------------------------------------------------------------------------|------------|
| Casting and Drawings Set<br>Supplied with all the drawings and required unmachined castings<br>* Base plate supplied in Aluminium and Flywheel supplied in Cast Iron                                                                                                         | RX-CASTKIT |
| Full Build Kit<br>Supplied with all the drawings, unmachined castings and all the required materials and fastenings to complete the build<br>* Base plate supplied in Aluminium and Flywheel supplied in Cast Iron<br>** Globe Valve and Drain Cocks are supplied separately | RX-FULLKIT |

*We are able to offer these kits with the alternative casting options, please contact us for a price*

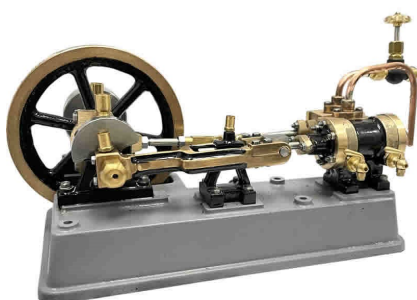

A very attractive stationary engine in the style of Maudsley and based on an English prototype designed and drawn by W. Schneeberger. Dimensions and drawing measurements are in metric. Built in a scale of 1:5.



### Specification

|                   |       |
|-------------------|-------|
| Height            | 300mm |
| Flywheel Diameter | 180mm |
| Bore              | 30mm  |
| Stroke            | 48mm  |

| Drawings / Notes | SKU   |
|------------------|-------|
| Drawing          | 15107 |

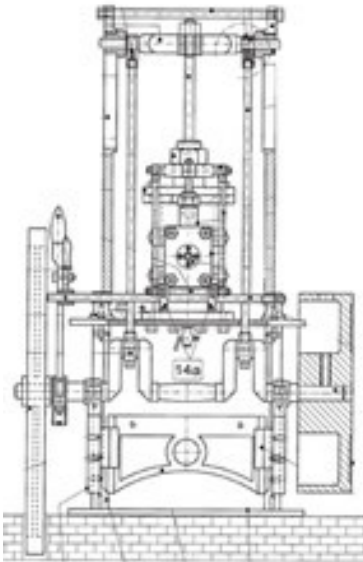

| Item / Product / Casting         | SKU |
|----------------------------------|-----|
| Distance Plate Support (4 Req)   | 02  |
| Side Frame Crank Support (2 Req) | 03  |
| Cylinder Cover                   | 04  |
| Side Frame (2 Req)               | 05  |
| Large Crosshead                  | 06  |
| Cylinder Block                   | 07  |
| Pulley                           | 08  |

| Item / Product / Casting | SKU |
|--------------------------|-----|
| Steam Chest              | 09  |
| Lever                    | 10  |
| Small Lever              | 20  |
| Small Crosshead          | 21  |
| Side End Frame (2 Req)   | 28  |
| Flywheel                 | 31  |

| Drawings and Casting Set                                                                                                                                                                                                                                                                                                                               | SKU             |
|--------------------------------------------------------------------------------------------------------------------------------------------------------------------------------------------------------------------------------------------------------------------------------------------------------------------------------------------------------|-----------------|
| Castings and Drawings Set<br>Supplied with the full drawings set and all required unmachined castings<br>- 2 x Distance Plate Support, 2 x Crank Support Side Frame, Cylinder Cover, 2 x Side Frame, Large & Small Crosshead, Cylinder Block, Pulley, Steam Chest, Lever, Small Lever & Flywheel.<br>* All castings are supplied in Gun Metal material | SUZ<br>BUILDKIT |

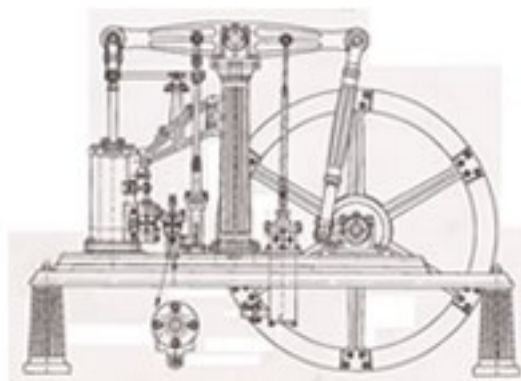

Lara Beam Engine—Originated by W. Schneeberger and developed by EKP

**Specification**

|                      |       |
|----------------------|-------|
| Length               | 410mm |
| Depth                | 180mm |
| Height               | 340mm |
| Flywheel Diameter    | 230mm |
| Main Beam Arm Length | 220mm |



Lara is a very attractive Beam engine and is designed to exhibition standard. This beam engine makes for a very satisfying build and is ideal for the more experienced Model Engineer

|                  |        |
|------------------|--------|
| Full Drawing Set | L-DRAW |
|------------------|--------|

| Item / Product / Casting        | SKU    |
|---------------------------------|--------|
| Base Plate - CI                 | L1-CI  |
| Beam Arm - CI                   | L2-CI  |
| Cylinder Block - CI             | L3-CI  |
| Bearing Support - Short (2 Req) | L4-GM  |
| Bearing Support - Tall (2 Req)  | L5-GM  |
| Main Lever - CI                 | L6-CI  |
| Inner Cylinder Cover            | L7-GM  |
| Upper Column Base               | L8-GM  |
| Air Pump Housing                | L9-GM  |
| Eccentric Strap                 | L10-GM |
| Flywheel - CI                   | L11-CI |
| Cam Disc                        | L12-GM |
| Cover Casting                   | L13-GM |
| Pump Housing - Small            | L14-GM |
| Pump Housing - Large            | L15-GM |
| Mounting Pad - Small            | L16-GM |
| Column Upright - CI             | L17-CI |
| Mounting Pad                    | L18-GM |

| Item / Product / Casting  | SKU    |
|---------------------------|--------|
| Wheel Mounting Block - CI | L19-CI |
| Angle Support - CI        | L20-CI |
| Angle Bracket - CI        | L21-CI |
| Steam Chest - CI          | L22-CI |
| Eccentric Strap           | L23-GM |

| <i>Alternative Casting Material Options</i> |        |
|---------------------------------------------|--------|
| Base Plate - GM                             | L1-GM  |
| Beam Arm - GM                               | L2-GM  |
| Cylinder Block - GM                         | L3-GM  |
| Main Lever - GM                             | L6-GM  |
| Flywheel - GM                               | L11-GM |
| Column Upright - GM                         | L17-GM |
| Wheel Mounting Block - GM                   | L19-GM |
| Angle Support - GM                          | L20-GM |
| Angle Bracket - GM                          | L21-GM |
| Steam Chest - GM                            | L22-GM |

| Drawings and Casting Set                                                                                                                                                                                                                                                                                                                                                                                                | SKU           |
|-------------------------------------------------------------------------------------------------------------------------------------------------------------------------------------------------------------------------------------------------------------------------------------------------------------------------------------------------------------------------------------------------------------------------|---------------|
| Casting and Drawings Set<br>Supplied with all full drawings and required unmachined castings<br>* The following castings are supplied in cast iron; Base Plate, Beam Arm, Cylinder Block, Main Lever, Flywheel, Column Upright, Wheel Mounting Pad, Angle Support, Angle Bracket and Steam Chest. The remaining castings will all be supplied in Gun Metal<br>Please note that this will all be confirmed when launched | LARA-BUILDKIT |
| <i>We will be able to offer these kits with the alternative casting options</i>                                                                                                                                                                                                                                                                                                                                         |               |

# Sensitive Drill

# Models

Sensitive Drilling Machine by Terry Aspin.  
 1/4" Capacity with a heavy weight for accurate and stable drilling



| Drawings / Notes                    | SKU             |
|-------------------------------------|-----------------|
| Full Drawing Set<br>- 3 Sheets (A1) | SENDRIL-DRAWSET |
| Construction Notes                  | SENDRIL-NOTES   |

| Item / Product / Casting | SKU |
|--------------------------|-----|
| Head Stock - CI          | AD1 |
| Table Support - CI       | AD2 |
| Belt Guide - CI          | AD3 |
| Drill Base - CI          | AD4 |
| Drill Table - CI         | AD5 |
| Pulley - AL (2 Req)      | AD6 |
| Belt Guide Pulley - AL   | AD7 |

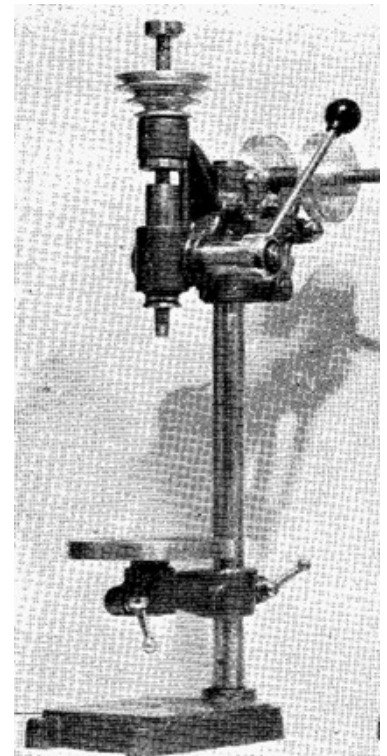

| Drawings and Casting Set                                                                                                                      | SKU              |
|-----------------------------------------------------------------------------------------------------------------------------------------------|------------------|
| Castings and Drawings Set<br>Supplied with the full drawings set, construction notes all required unmachined castings and additional material | SENDRIL-BUILDKIT |

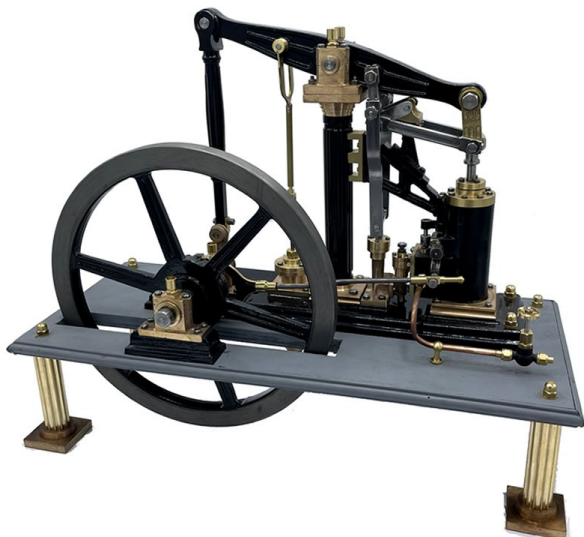

Here is an image of our Lara Beam Engine Featured to the left on Page 64.

## Model

## Single (Donkey) & Duplex Cylinder Weir Pump

Single Cylinder driving a single 7/32" dia pump ram.

Twin (Duplex) Pump driving two single or double acting 7/32" dia pump rams



Specification

Pump Bore Diameter 3/8"

Specification

Pump Bore Diameter 5/16"

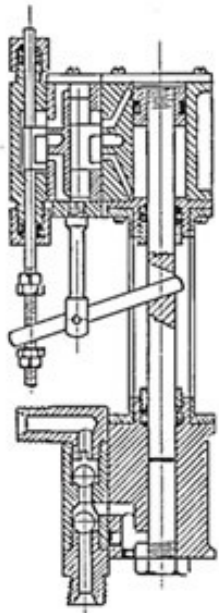

| Drawings                               | SKU   |
|----------------------------------------|-------|
| Single Cylinder Drawing - 1 Sheet (A2) | 15155 |
| Twin Cylinder Drawing - 1 Sheet (A2)   | 15156 |

| Casting Stick                                                                                        | SKU |
|------------------------------------------------------------------------------------------------------|-----|
| Casting Stick containing the main components in a single stick<br>Supplied with cutting instructions | AAK |
| Casting Stick containing the main components in a single stick<br>Supplied with cutting instructions | AAJ |

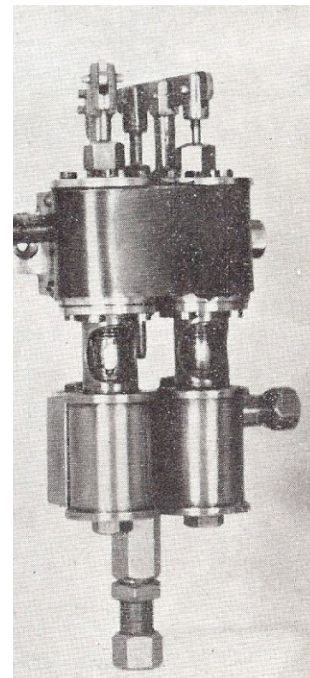

## Model

## 3 1/2" Gauge Service Truck

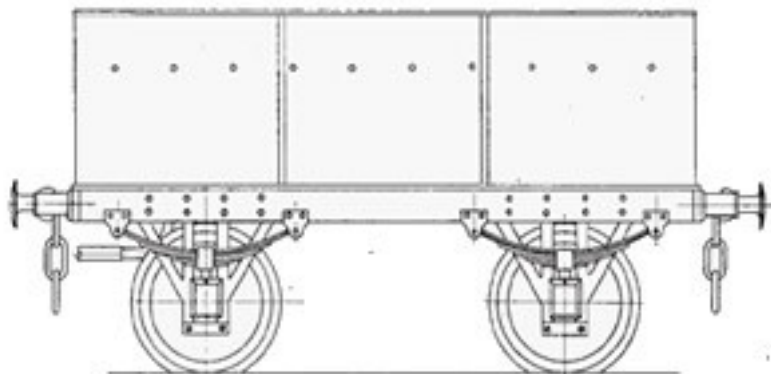

Four Wheel Service, Coal and Water Carrying Wagon

Specification

Overall Length: 12 3/4"  
Width: 6"  
Wheel Outside Diameter: 2 1/2"



A very versatile 3 1/2" Gauge Service wagon which with very little adjustment can be built as either a Goods Wagon, Service Wagon or Trailer Wagon.

|                              |       |
|------------------------------|-------|
| Drawing & Construction Notes | 15163 |
|------------------------------|-------|

| Item / Product / Casting | SKU  |
|--------------------------|------|
| Axle Box Strip           | CF2  |
| Service Truck Wheel - CI | 3BTE |

| Item / Product / Casting     | SKU    |
|------------------------------|--------|
| Spring with Drop Arms        | 3MTSP  |
| Laser Cut Service Truck Horn | GLR056 |

All other materials required are available to purchase online or via our main retail catalogue

## Bogie Castings

## Model

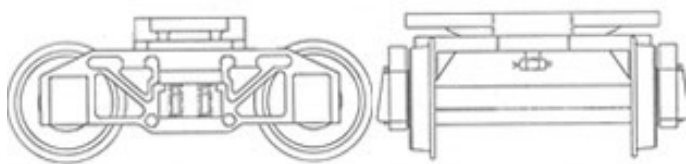

|                                      |          |
|--------------------------------------|----------|
| 3 1/2" Bogie Drawing - 1 Sheet (-)   | 3-12BOGD |
| 3 1/2" Bogie Brake Drawing - 1 Sheet | 3-12BOGB |

| Item / Product / Casting         | SKU   |
|----------------------------------|-------|
| Bogie Bolster - Aluminium        | 84    |
| Bogie Cross Beam - Aluminium     | 84A   |
| Bogie Side Frame L/H - Aluminium | 82L   |
| Bogie Side Frame R/H - Aluminium | 82R   |
| Wheel - CI (4 Req)               | 3BW   |
| Bogie Brake Links                | 73    |
| Brake Shoe Ring                  | DB1GM |



High quality Aluminium Bogies available in 3 1/2", 5" & 7 1/4" Gauge. These can be built with or without brakes

|                                  |       |
|----------------------------------|-------|
| 5" Bogie Drawing - 1 Sheet (-)   | 15146 |
| 5" Bogie Brake Drawing - 1 Sheet | 15149 |

|                                      |       |
|--------------------------------------|-------|
| 7 1/4" Bogie Drawing - 1 Sheet (-)   | 15147 |
| 7 1/4" Bogie Brake Drawing - 1 Sheet | 15148 |

| Item / Product / Casting         | SKU   |
|----------------------------------|-------|
| Bogie Bolster - Aluminium        | 80    |
| Bogie Cross Beam - Aluminium     | 81    |
| Bogie Side Frame L/H - Aluminium | 86    |
| Bogie Side Frame R/H - Aluminium | 85    |
| Wheel - CI (4 Req)               | 57000 |
| Bogie Brake Links                | 74    |
| Brake Shoe Ring                  | DC1GM |

| Item / Product / Casting         | SKU   |
|----------------------------------|-------|
| Bogie Bolster - Aluminium        | 89    |
| Bogie Cross Beam - Aluminium     | 90    |
| Bogie Side Frame L/H - Aluminium | 88    |
| Bogie Side Frame R/H - Aluminium | 87    |
| Wheel - CI (4 Req)               | 7BW   |
| Bogie Brake Links                | 75    |
| Brake Shoe Ring                  | DE3GM |

## Cast Wheel for 5" Gauge Passenger Trucks

## Tee & Elbow Castings



Cast Wheel, Horn and Axle Box for 5" Gauge Passenger Trucks.

Specification

Wheel Outside Diameter: 3 1/8"

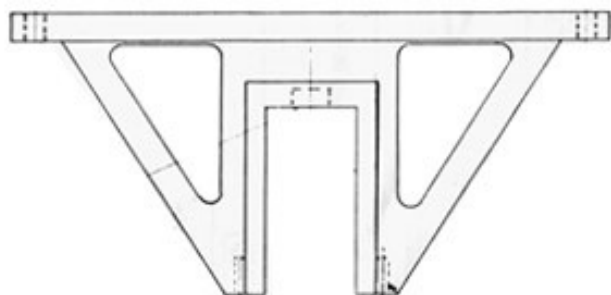

Tee & Elbow Castings. Available in four sizes and each casting will make four elbows and two tees



|                                 |       |
|---------------------------------|-------|
| Full Drawing Set - 1 Sheet (A2) | 15150 |
|---------------------------------|-------|

| Item / Product / Casting | SKU   |
|--------------------------|-------|
| Horn - Aluminium         | PAS1  |
| Axle Box - Aluminium     | AAS   |
| Wheel - Cast Iron        | 57000 |
| 1/2" I/D Ball Race       | BR8   |

| Pipe Size                                       | SKU |
|-------------------------------------------------|-----|
| For 1/8" or 5/32" Pipe (1/4" x 40tpi Union Nut) | TE1 |
| For 3/16" Pipe (5/16" x 32tpi Union Nut)        | TE2 |
| For 1/4" or 5/16" Pipe (3/8" x 32tpi Union Nut) | TE3 |
| 5/16" or 3/8" Pipe (1/2" x 26tpi Union Nut)     | TE4 |

# Notes

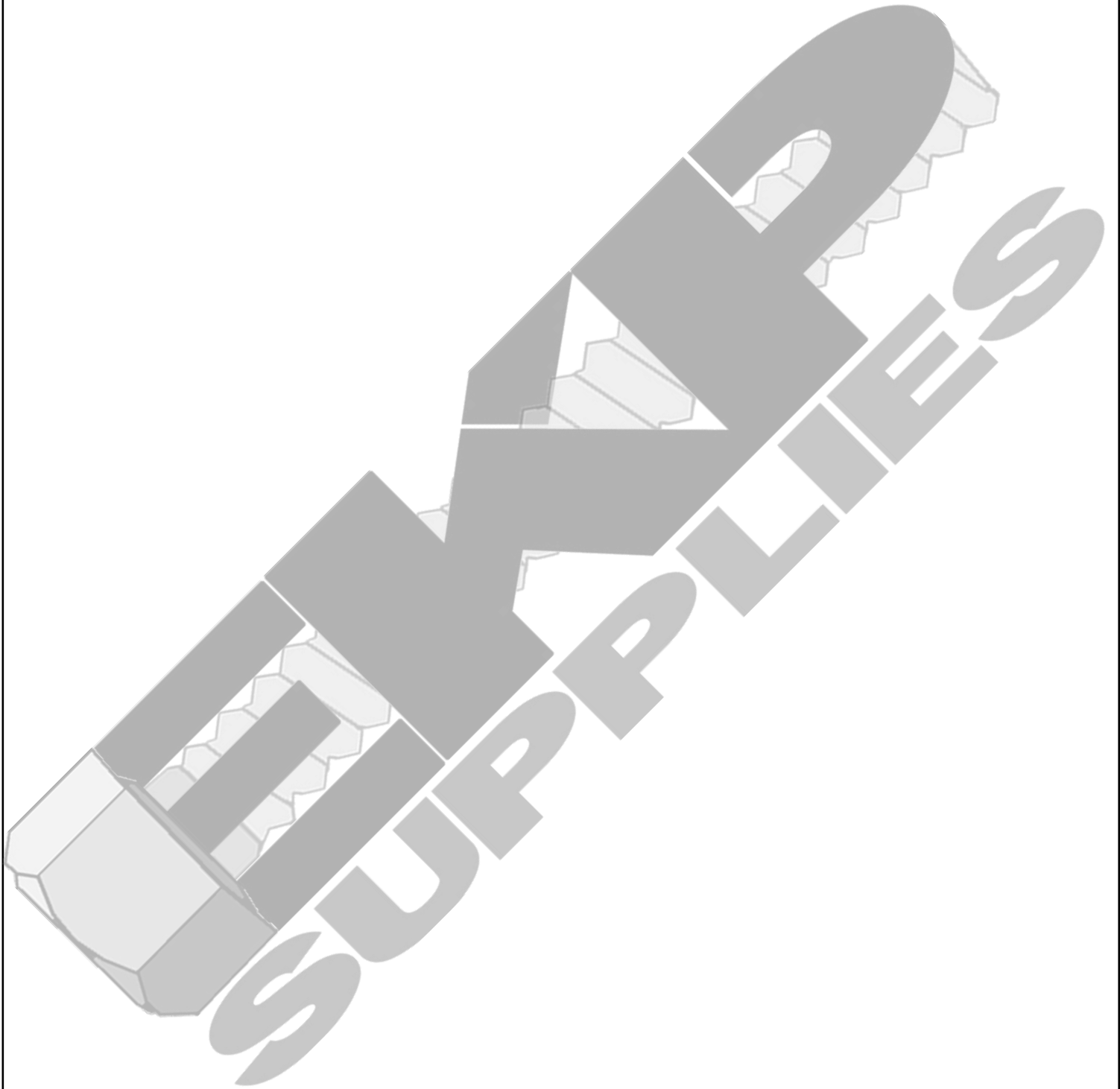

# Notes

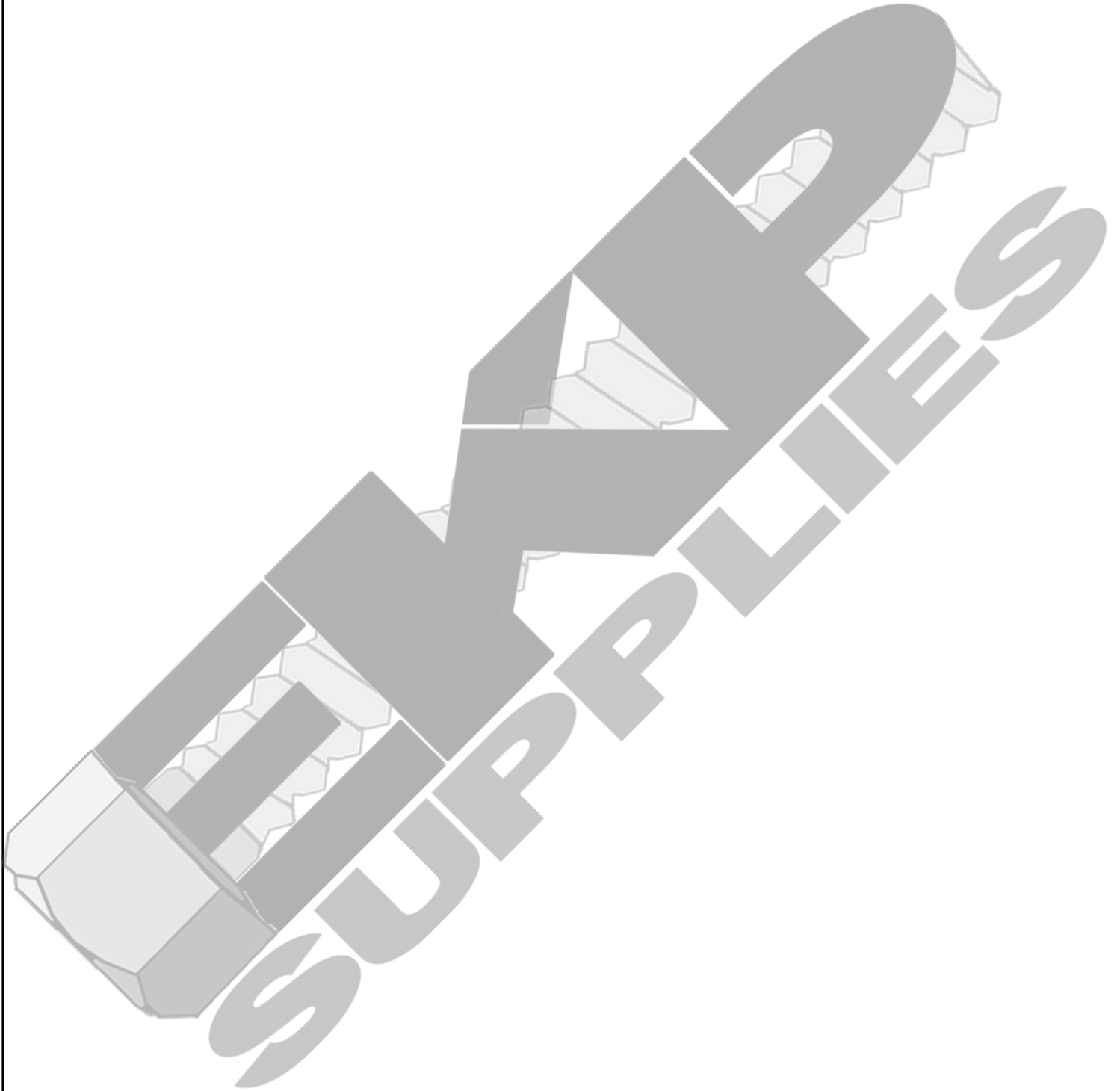

# EKP SUPPLIES

We are pleased to be able to offer the drawings and castings for 3 Burrell Traction engines in our large and expanding product range. Each of the engines have been designed and built by ourselves.

Below is a brief outline of each model available including our 6" scale haulage wagon



## 4" and 8" Gold Medal Tractor

Our 4" scale Burrell Tractor is scaled down model of our popular 8" version. The 8" Tractor has been based upon the single cylinder light haulage of which the Burrell works only produced a small quantity of

## 6" Burrell Agricultural Engine

The Agricultural Engine is based upon the early Burrell with single drive and differential on the rear axle but with the added benefit of front springs



## 6" Scale Haulage Wagon

Designed by us to compliment our 6" engine and 8" tractor

**For full catalogues and information please contact us on the details below**

**EKP Supplies**  
**Unit A3, Brannam Court,**  
**Roundswell Business Park**  
**Barnstaple**  
**EX31 3TD**

**WWW.EKPSUPPLIES.COM**  
**SALES@EKPSUPPLIES.COM**  
**01271 346 441**