

120 [4.72]

103.4 [4.07]

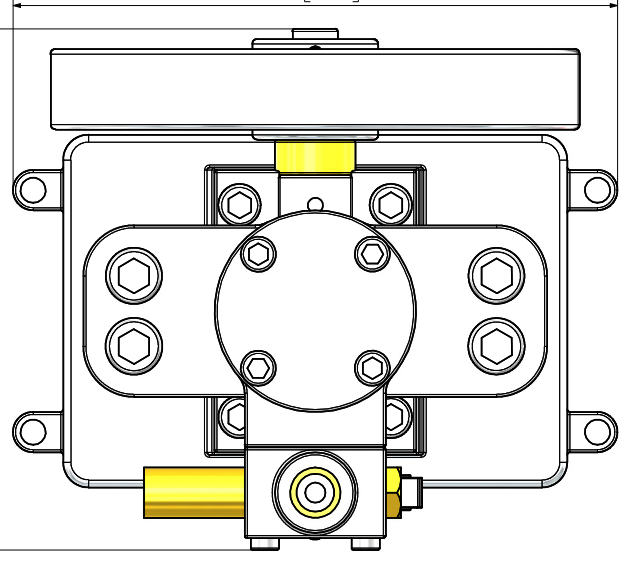

STEAM OUT

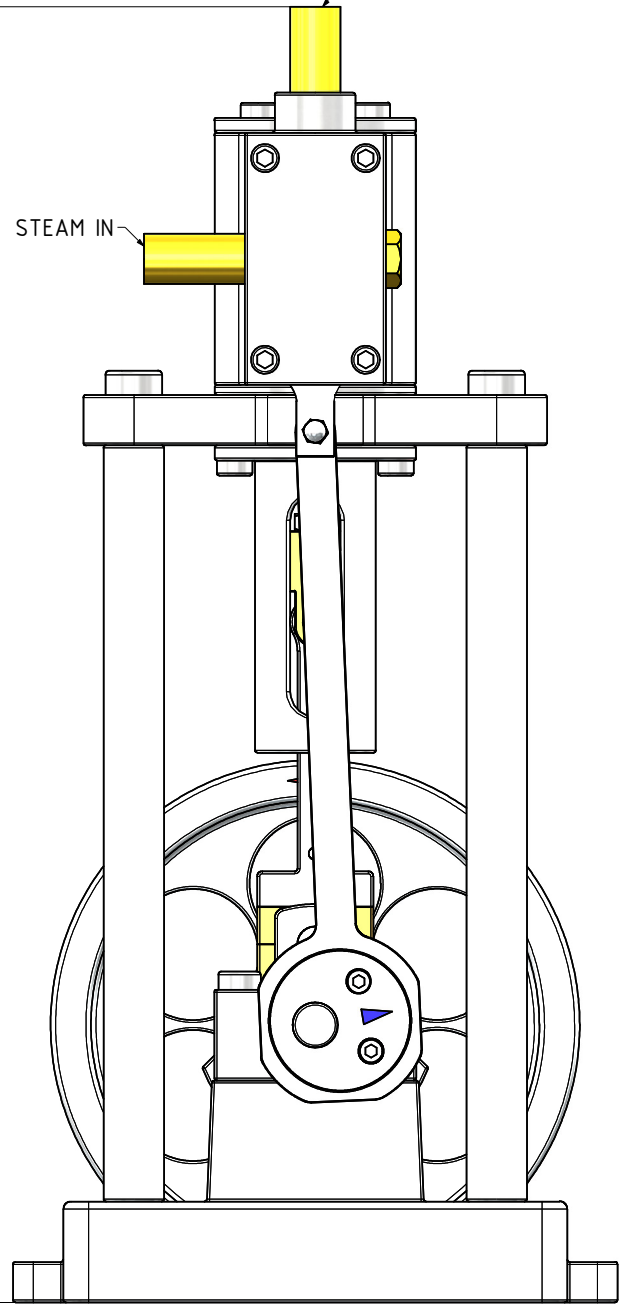

257 [10.12]

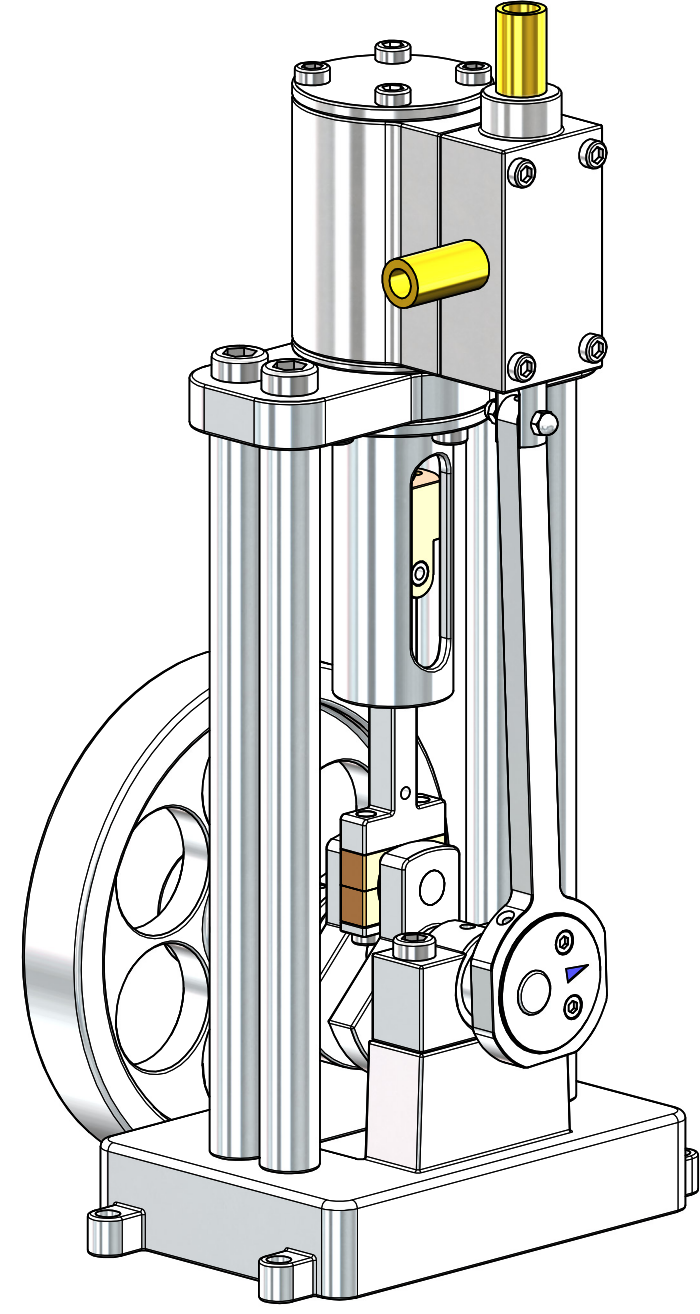
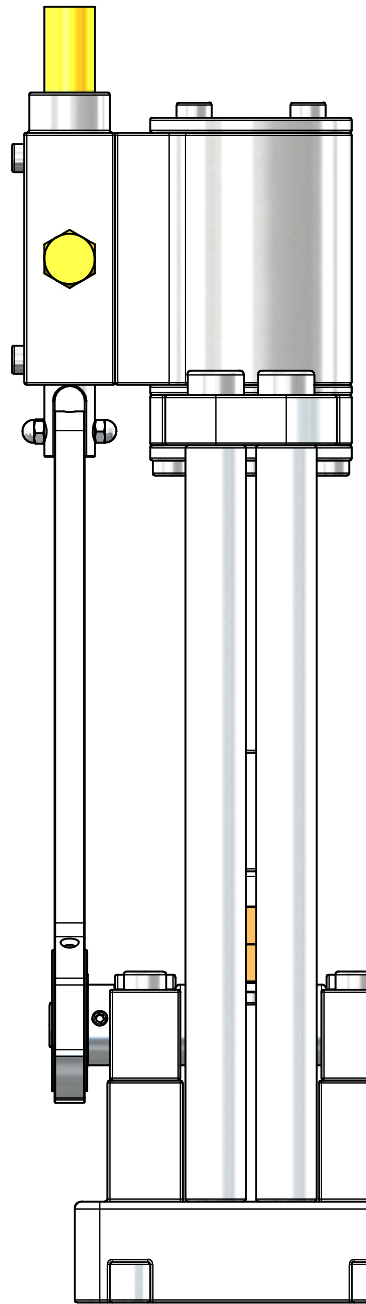

GENERAL NOTES:  
 0. ALL DRAWINGS ARE IN METRIC MEASUREMENTS  
 1. ALL ENGINEERING PRACTICES SHALL BE APPLIED WITH REGARDS TO HOLE AND SHAFT TOLERANCES.  
 2. WHERE SCREWS OR BOLTS ARE USED THE CLEARANCE HOLES SHALL BE APPROXIMATELY 5% TO 8% LARGER THAN THE MATCHING TAPPED HOLE.  
 3. PREFERABLY ALL TAPPED HOLES AND MATCHING SCREWS AND/OR BOLTS TO BE METRIC FINE (MF)  
 4. MATERIALS SPECIFIED ON THE DRAWINGS ARE INDICATIVE ONLY. THE BUILDER CAN MAKE HIS/HER OWN MATERIAL CHOICE.  
 5. ALL CONNECTIONS/JOINTS WHICH HAVE STEAM PRESSURE APPLIED TO IT SHALL BE SILVER/HARD SOLDERED.  
 6. COMPRESSION SPRINGS ARE DRAWN IN COMPRESSED STATE (CP), UNCOMPRESSED STATE IS APPROX 40% TO 60% LONGER THEN COMPRESSED STATE.  
 7. WHERE PREFERRED SCREW OR RIVETED CONNECTIONS CAN BE OMITTED AND PARTS CAN BE BONDED TOGETHER BY USING EITHER HIGH STRENGTH GLUE, EPOXY RESIN, OR SOLDER.  
 8. PARTS WHICH ARE DIRECTLY EXPOSED TO STEAM AND/OR WATER SHOULD BE CONSTRUCTED USING NON-FERROUS OR NON CORROSIVE MATERIAL SUCH AS BRASS, BRONZE, GUNMETAL, STAINLESS STEEL, COPPER OR MONEL.  
 9. THE ORDER IN WHICH THE PARTS/COMPONENTS ARE MANUFACTURED AND THE MODEL IS ASSEMBLED IS ENTIRELY LEFT TO THE BUILDER/MODEL MAKER.  
 10. A COLOUR SCHEME FOR THIS PROJECT IS ENTIRELY LEFT UP TO THE MODEL MAKER.  
 11. THE MANNER IN WHICH THE PARTS/COMPONENTS ARE MANUFACTURED IS ENTIRELY LEFT UP TO THE BUILDER.  
 12. USE LOCTITE, ON SCREW OR PRESS FIT CONNECTIONS OR SURFACES, WERE DEEMED NECESSARY TO PREVENT PARTS FROM LOOSENING.  
 13. WASHERS AND/OR SPRING WASHERS SHALL BE USED WHERE DEEMED NECESSARY.  
 14. USE SEALING GASKETS WERE DEEMED NECESSARY.  
 15. REMOVE ALL SHARP EDGES  
 XX. ERRORS AND/OR OMISSIONS MAY OCCUR IN THE DRAWINGS, DO NOT HESITATE TO CONTACT ME SO THAT THE ERRORS/OMISSIONS CAN BE RECTIFIED.

MATERIAL ABBREVIATIONS:  
 ALU = ALUMINIUM  
 HALU= HARD ALUMINIUM  
 BRS = BRASS  
 PBRZ= PHOSPHORE BRONZE  
 BRZ = BRONZE OR GUNMETAL (BRZ/GM)  
 OLT = OILITE  
 CI = CAST IRON  
 CU = COPPER  
 GRA = GRAPHITE  
 MS = MILD STEEL/BRIGHT MILD STEEL  
 SS = SILVER STEEL OR STAINLESS STEEL  
 SPS = SPRING STEEL  
 PEEK= POLYETHER ETHER KETONE  
 SYN = SYNTHETIC MATERIAL SUCH AS VETON, NYLON, TEFLON OR RUBBER  
 IN GENERAL SYNTHETIC MATERIALS SHOULD BE ABLE TO WITHSTAND THE HEAT AND PRESSURE(S) APPLIED TO THEM.  
 nnn/nnn MEANS THAT EITHER MATERIAL CAN BE USED

OTHER ABBREVIATIONS  
 AS = AS SHOWN  
 DP = DEEP  
 DAA= DRILL AFTER ASSEMBLY  
 D&TAA= DRILL AND TAP AFTER ASSEMBLY  
 CF = CLOSE FIT (SIZE FOR SIZE)  
 PF = PRESS FIT  
 PFAA= PRESS FIT AFTER ASSEMBLY  
 PCD = PITCH CIRCLE DIAMETER  
 RM = REAM  
 HEX = HEXACON, 6SIDED  
 CP = COMPRESSED  
 KNL = KNURLED  
 CSK = COUNTERSINK  
 PL = PLACES  
 DWL= DOWEL  
 SPF= SPOTFACE  
 (T)HESOP=(TAPPED)HOLES EQUALLY SPACED ON PCD  
 (T)HESOC=(TAPPED)HOLES EQUALLY SPACED ON CIRCUMFERENCE  
 OD = OUTSIDE DIAMETER  
 ID = INSIDE DIAMETER  
 MAX/MIN = CRITICAL DIMENSION  
 [SA-xxx]= SUB ASSEMBLY-xxx

DUE TO THE LACK OF INFORMATION ON THE ORIGINAL DRAWING(S), SUCH AS VIEWS, DIMENSIONS, SECTIONS ETC AND/OR CLARITY OF COMPONENTS, OMITTED PARTS/COMPONENTS, SOME OF THE COMPONENTS MIGHT NOT BE AS CONSTRUCTED ORIGINALLY OR AS THE ORIGINAL DESIGNER INTENDED

THE OFF SET ANGLE OF THE ECCENTRIC IN RELATION TO THE CRANK AXIS TO BE EXPERIMENTALLY DETERMINED FOR THE SMOOTH RUNNING OF THE ENGINE AND SATISFACTION OF THE BUILDER

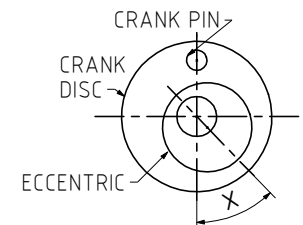

QTY	PART NUMBER
1	09C-71-00-1-01-BASE+ENGINE PLATFORM
1	09C-71-00-1-02-CYLINDER+VALVE CHEST
1	09C-71-00-1-03-CROSS HEAD TRUNK GUIDE
1	09C-71-00-2-01-CRANK SHAFT+FLYWHEEL
1	09C-71-00-2-02-PISTON+CROSSHEAD
1	09C-71-00-2-03-CON-ROD
1	09C-71-00-2-04-SPOOL VALVE
1	09C-71-00-2-05-ECCENTRIC STRAP
2	09C-71-00-M3 DOME NUT
3	09C-71-00-M3x3.5 A-K GRUB SCREW
2	09C-71-00-M3x7 A-K C-SINK SCREW
1	09C-71-00-M3x8 A-K GRUB SCREW
1	09C-71-00-M4 NUT
6	09C-71-00-M4x24 A-K CYL HEAD SCREW
1	09C-71-00-M5 NUT
4	09C-71-00-M5x12 A-K CYL HEAD SCREW
4	09C-71-00-M5x64 A-K CYL HEAD SCREW
4	09C-71-00-M6x26 A-K CYL HEAD SCREW
8	09C-71-00-M8x24 A-K CYL HEAD SCREW

NOTES: THE ENGINE SHOWN ON THESE DRAWINGS ARE LOOSLY BASED ON A UNDIMENSIONED DRAWING AND PICTURES WHICH I FOUND ON THE INTERNET. THE DRAWING WAS DRAWN BY SIMON ROWLEY, AND DATED SEPT-2018. NO SCALE INDICATED.

TITLE  
**1 CYLINDER NON REVERSABLE VERTICAL STEAM ENGINE (BORE=22mm STROKE=32mm)**

DRAWING CONTENTS  
**GENERAL ARRANGEMENT, ISOMETRIC VIEW, NOTES, BILL OF MATERIALS**

PROJECT No 09C-71-00  
 JDW DRAUGHTING SERVICES  
 J.A.M. DE WAAL, 12 BRIGHTWELL STREET PAPAOKURA  
 2110, NEW ZEALAND. PHONE: 0064 09 2988815. MOB: 0211791000 E-MAIL: dewaal@xtra.co.nz.

PROJECTION  
  
 DATE AUGUST 2025  
 SHEET: 01 OF 03

MODEL SCALE: 1:1  
 DWG SCALE: 1:1 @A3 OR AS SHOWN  
 Copyright © J.A.M. DE WAAL PAPAOKURA NZ  
**A3 No:09C-71-00-SHT-01**

**DRAWINGS ARE FOR PERSONAL USE ONLY NOT FOR COMMERCIAL PURPOSES**