

How the valves work

This engine uses a unique slave exhaust valve. It is a spring loaded, sliding piston which is activated by the pressure of incoming compressed air when the inlet valve is opened by the cam operated push rod. This design lends itself to compressed air engines of any number of cycles. It's particularly useful on hit n miss operated engines, since the exhaust valve will remain open as long as the inlet valve is closed. This allows the engine to turn over multiple times with no back pressure due to compression.

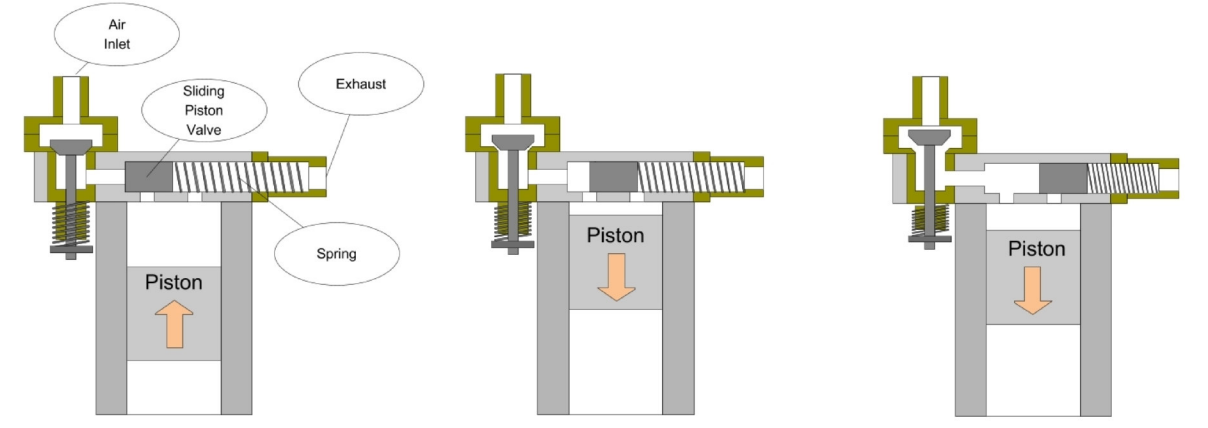

Here, the inlet valve is closed. The spring keeps the slave exhaust valve pushed to the left, exposing the cylinder to the exhaust port. This allows the free passage of air into and out of the cylinder with no back pressure.

As the inlet valve begins to open, high pressure air enters the head and begins pushing the slave exhaust valve to the right. This opens the input port and lets the high pressure air into the cylinder. The exhaust port is still partially open, which allows some of the high pressure air to go directly to the exhaust, giving the engine its distinctive pop when it "fires".

As the inlet valve continues to open, the slave exhaust valve is pushed all the way to the right, completely closing off the exhaust port and forcing all the high pressure air into the cylinder. This is the power stroke and will continue to push the piston down until the inlet valve is closed. At that time, the spring again pushes the slave exhaust valve to the left, letting the high pressure air in the cylinder exhaust to the outside.

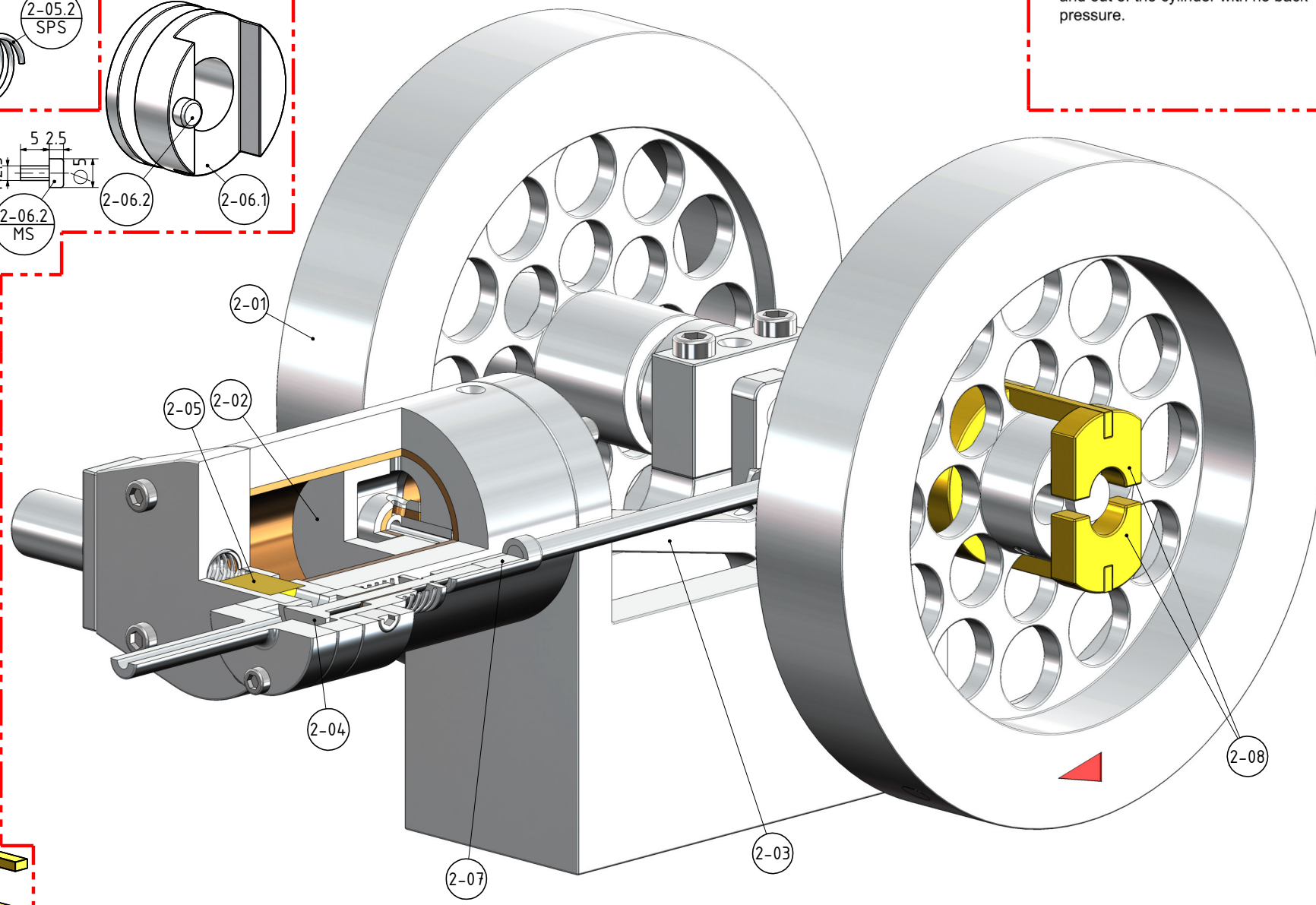

NOTE:
 1) WHEN THE ENGINE IS RUNNING AT LOW SPEED THEN THE OPERATING PIN ON THE SLIDING CAM (PART 2-03) WILL OPERATE THE ACTUATING FORK (PART 2-07) WHICH IN TURN WILL OPEN AND CLOSE THE AIR INLET VALVE (PART 2-04).
 2) WHEN THE ENGINE IS RUNNING AT HIGH SPEED THE FLYWEIGHTS (PARTS 2-08) WILL HAVE OPERATED THE SLIDING CAM (PART 2-03) AND THE PIN ON THE SLIDING CAM HAS MOVED AWAY FROM THE ACTUATING FORK (PART 2-07) AND THUS DOES NOT OPERATE THE AIR INLET VALVE (PART 2-04).
 3) WHEN THE SPEED HAS FALLEN SUFFICIENT ENOUGH PARAGRAPH 1) WILL COME IN ACTION.
 A SMALL VIDEO IS AVAILABLE TO SEE THE ACTIONS AS DESCRIBED ABOVE

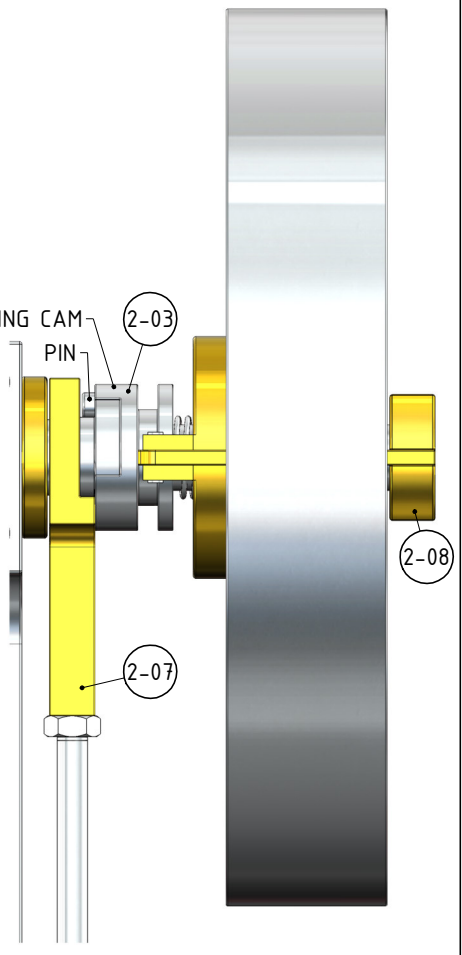

NOTES: THE ORIGINAL DRAWINGS WERE GIVEN TO ME. THE ORIGINAL DESIGNER AND CONSTRUCTOR OF THIS ENGINE WAS Mr BRIAN RUPNOW. DRAWING TITLE "HIT AND MISS AIR MOTOR", DRAWINGS DATED 6/10/2009. ENGINE SHOWN ON THESE DRAWINGS IS TWICE OF THE ORIGINAL DESIGN.

TITLE
1 CYLINDER HORIZONTAL "HIT AND MISS" AIR ENGINE (BORE=38mm STROKE=62mm)

DRAWING CONTENTS
PARTS AND ASSEMBLIES

PROJECT No 09F-02-00
 JDW DRAUGHTING SERVICES
 J.A.M. DE WAAL, 12 BRIGHTWELL STREET PAPA KURA
 2110, NEW ZEALAND. PHONE: 0064 09 2988815. MOB: 0211791000 E-MAIL: dewaal@xtra.co.nz.

PROJECTION
JDWDS
 DATE APRIL 2025
 SHEET: 03 OF 03

MODEL SCALE: 1:1
 DWG SCALE: 1:1 @A3 OR AS SHOWN
 Copyright © J.A.M. DE WAAL PAPA KURA NZ
A3 No:09F-02-00-SHT-03