

DUE TO THE LACK OF INFORMATION ON THE ORIGINAL DRAWING(S), SUCH AS VIEWS, DIMENSIONS, SECTIONS ETC AND/OR CLARITY OF COMPONENTS, OMITTED PARTS/COMPONENTS, SOME OF THE COMPONENTS MIGHT NOT BE AS CONSTRUCTED ORIGINALLY OR AS THE ORIGINAL DESIGNER INTENDED

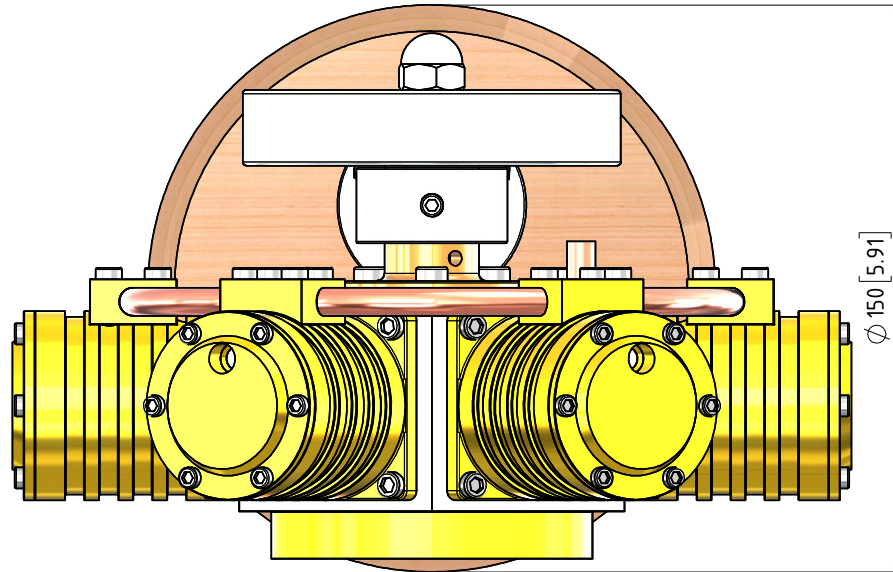

∅ 150 [5.91]

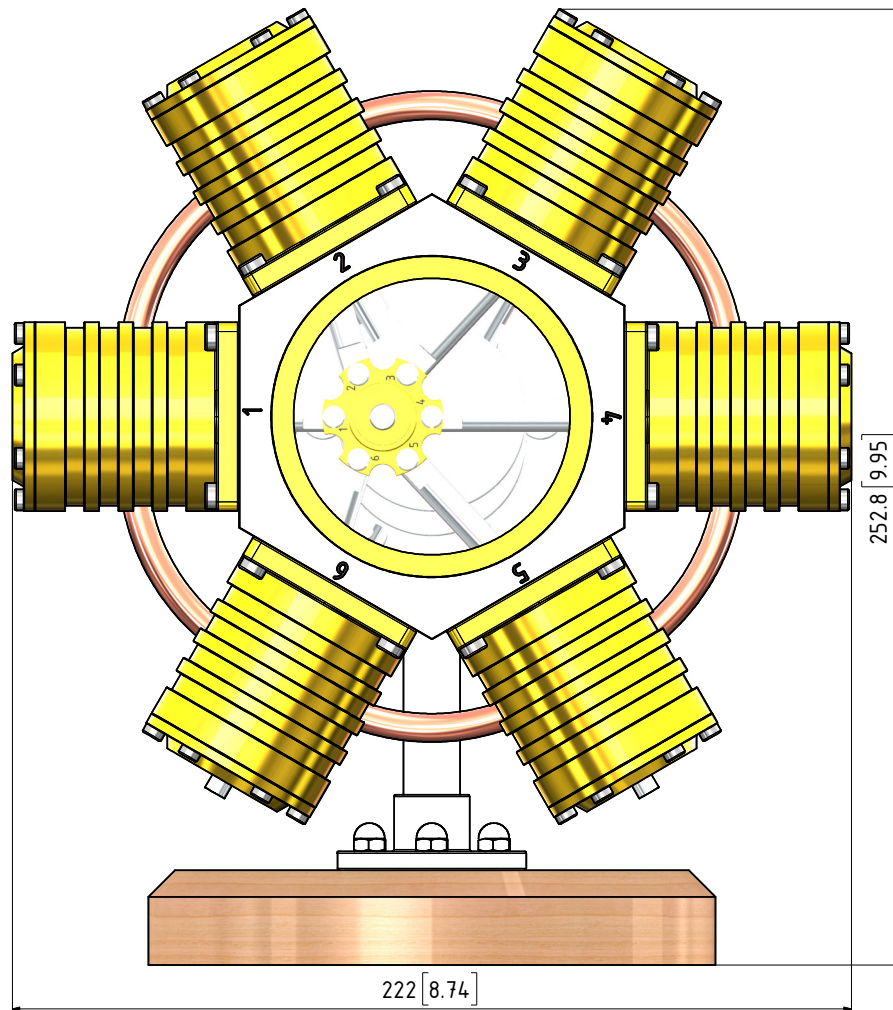

252.8 [9.95]

222 [8.74]

- GENERAL NOTES:
- ALL DRAWINGS ARE IN METRIC MEASUREMENTS
 - ALL ENGINEERING PRACTICES SHALL BE APPLIED WITH REGARDS TO HOLE AND SHAFT TOLERANCES.
 - WHERE SCREWS OR BOLTS ARE USED THE CLEARANCE HOLES SHALL BE APPROXIMATELY 5% TO 8% LARGER THAN THE MATCHING TAPPED HOLE.
 - PREFERABLY ALL TAPPED HOLES AND MATCHING SCREWS AND/OR BOLTS TO BE METRIC FINE (MF)
 - MATERIALS SPECIFIED ON THE DRAWINGS ARE INDICATIVE ONLY. THE BUILDER CAN MAKE HIS/HER OWN MATERIAL CHOICE.
 - ALL CONNECTIONS/JOINTS WHICH HAVE STEAM PRESSURE APPLIED TO IT SHALL BE SILVER/HARD SOLDERED.
 - COMPRESSION SPRINGS ARE DRAWN IN COMPRESSED STATE (CP), UNCOMPRESSED STATE IS APPROX 40% TO 60% LONGER THEN COMPRESSED STATE.
 - WHERE PREFERRED SCREW OR RIVETED CONNECTIONS CAN BE OMITTED AND PARTS CAN BE BONDED TOGETHER BY USING EITHER HIGH STRENGTH GLUE, EPOXY RESIN, OR SOLDER.
 - PARTS WHICH ARE DIRECTLY EXPOSED TO STEAM AND/OR WATER SHOULD BE CONSTRUCTED USING NON-FERROUS OR NON CORROSIVE MATERIAL SUCH AS BRASS, BRONZE, GUNMETAL, STAINLESS STEEL, COPPER OR MONEL.
 - THE ORDER IN WHICH THE PARTS/COMPONENTS ARE MANUFACTURED AND THE MODEL IS ASSEMBLED IS ENTIRELY LEFT TO THE BUILDER/MODEL MAKER.
 - A COLOUR SCHEME FOR THIS PROJECT IS ENTIRELY LEFT UP TO THE MODEL MAKER.
 - THE MANNER IN WHICH THE PARTS/COMPONENTS ARE MANUFACTURED IS ENTIRELY LEFT UP TO THE BUILDER.
 - USE LOCTITE, ON SCREW OR PRESS FIT CONNECTIONS OR SURFACES, WERE DEEMED NECESSARY TO PREVENT PARTS FROM LOOSENING.
 - WASHERS AND/OR SPRING WASHERS SHALL BE USED WHERE DEEMED NECESSARY.
 - USE SEALING GASKETS WERE DEEMED NECESSARY.
 - REMOVE ALL SHARP EDGES
 - XX. ERRORS AND/OR OMISSIONS MAY OCCUR IN THE DRAWINGS, DO NOT HESITATE TO CONTACT ME SO THAT THE ERRORS/OMISSIONS CAN BE RECTIFIED.

- OTHER ABBREVIATIONS
- AS = AS SHOWN
 - DP = DEEP
 - DAA= DRILL AFTER ASSEMBLY
 - D&TAA= DRILL AND TAP AFTER ASSEMBLY
 - CF = CLOSE FIT (SIZE FOR SIZE)
 - PF = PRESS FIT
 - PFAA= PRESS FIT AFTER ASSEMBLY
 - PCD = PITCH CIRCLE DIAMETER
 - RM = REAM
 - HEX = HEXACON, 6SIDED
 - CP = COMPRESSED
 - KNL = KNURLED
 - CSK = COUNTERSINK
 - PL = PLACES
 - DWL= DOWEL
 - SPF= SPOTFACE
 - (T)HESOP=(TAPPED)HOLES EQUALLY SPACED ON PCD
 - (T)HESOC=(TAPPED)HOLES EQUALLY SPACED ON CIRCUMFERENCE
 - OD = OUTSIDE DIAMETER
 - ID = INSIDE DIAMETER
 - MAX/MIN = CRITICAL DIMENSION
 - [SA-xxx]= SUB ASSEMBLY-xxx

- MATERIAL ABBREVIATIONS:
- ALU = ALUMINIUM
 - HALU= HARD ALUMINIUM
 - BRS = BRASS
 - PBRZ= PHOSPHORE BRONZE
 - BRZ = BRONZE OR GUNMETAL (BRZ/GM)
 - OLT = OILITE
 - CI = CAST IRON
 - CU = COPPER
 - GRA = GRAPHITE
 - MS = MILD STEEL/BRIGHT MILD STEEL
 - SS = SILVER STEEL OR STAINLESS STEEL
 - SPS = SPRING STEEL
 - PEEK= POLYETHER ETHER KETONE
 - SYN = SYNTHETIC MATERIAL SUCH AS VETON, NYLON, TEFLON OR RUBBER

IN GENERAL SYNTHETIC MATERIALS SOULD BE ABLE TO WITHSTAND THE HEAT AND PRESSURE(S) APPLIED TO THEM.
 nnn/nnn MEANS THAT EITHER MATERIAL CAN BE USED

QTY.	PART NUMBER
1	09E-72-00-1-01-ENGINE STAND
1	09E-72-00-1-02-CYLINDER HOUSING
6	09E-72-00-1-03-STEAM SUPPLY PIPE
1	09E-72-00-2-01-CRANKSHAFT+VALVE ECCENTRIC
1	09E-72-00-2-02-PISTON CROSSHEAD DISC
1	09E-72-00-2-03-CON-ROD TYPE-1
6	09E-72-00-2-04-PISTON
5	09E-72-00-2-05-CON-ROD TYPE-2
6	09E-72-00-2-06-SPOOL VALVE-1
1	09E-72-00-M10 DOME NUT
36	09E-72-00-M4x8 A-K CYL HEAD SCREW
3	09E-72-00-M5 DOME NUT
1	09E-72-00-M5 WASHER SPECIAL
1	09E-72-00-M5x10 A-K GRUB SCREW
24	09E-72-00-M5x14 A-K CYL HEAD SCREW
13	09E-72-00-M5x20 A-K CYL HEAD SCREW
3	09E-72-00-M5x35 A-K C-SINK SCREW
3	09E-72-00-M6x10 A-K CYL HEAD SCREW
3	09E-72-00-M6x8.5 A-K GRUB SCREW

THE OFF SET ANGLE OF THE ECCENTRIC IN RELATION TO THE CRANK AXIS TO BE EXPERIMENTALLY DETERMINED FOR THE SMOOTH RUNNING OF THE ENGINE AND SATISFACTION OF THE BUILDER

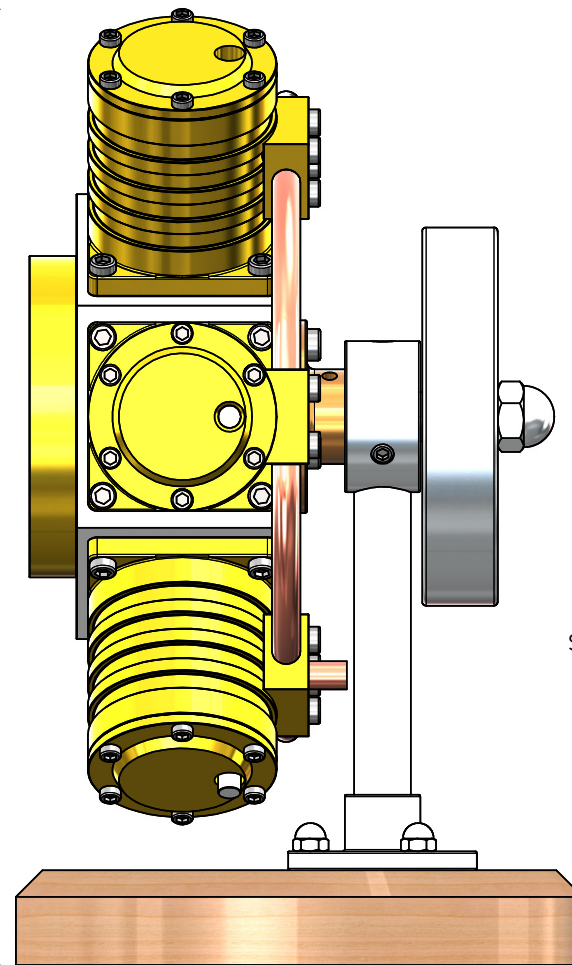
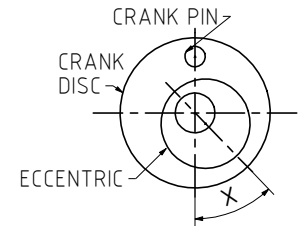

STEAM IN

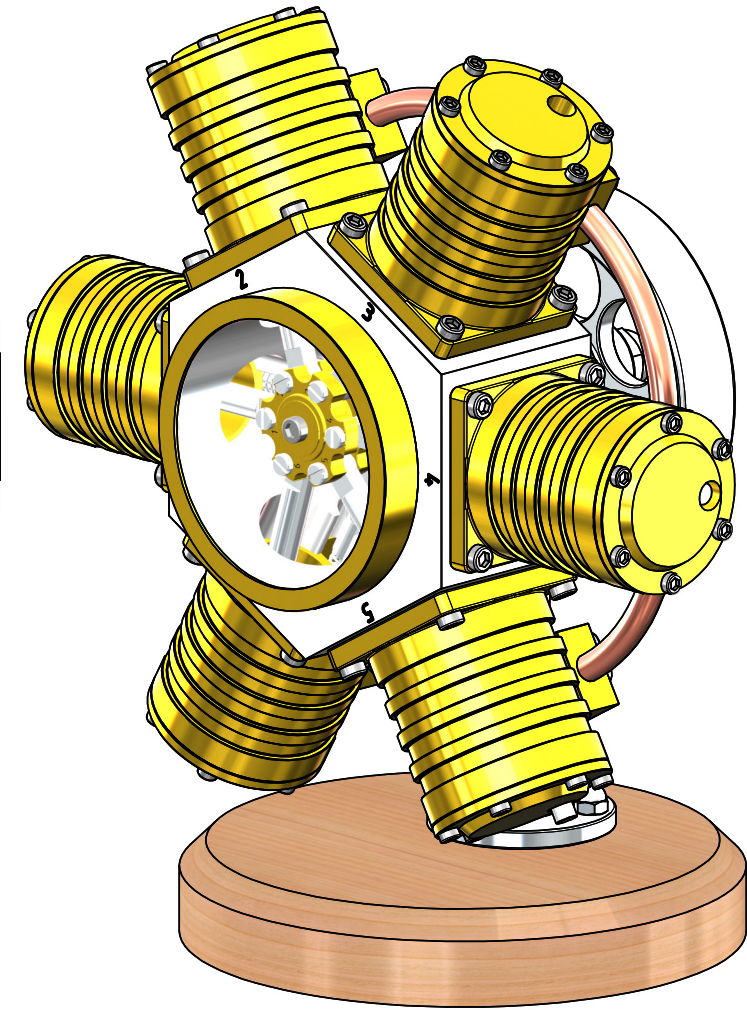
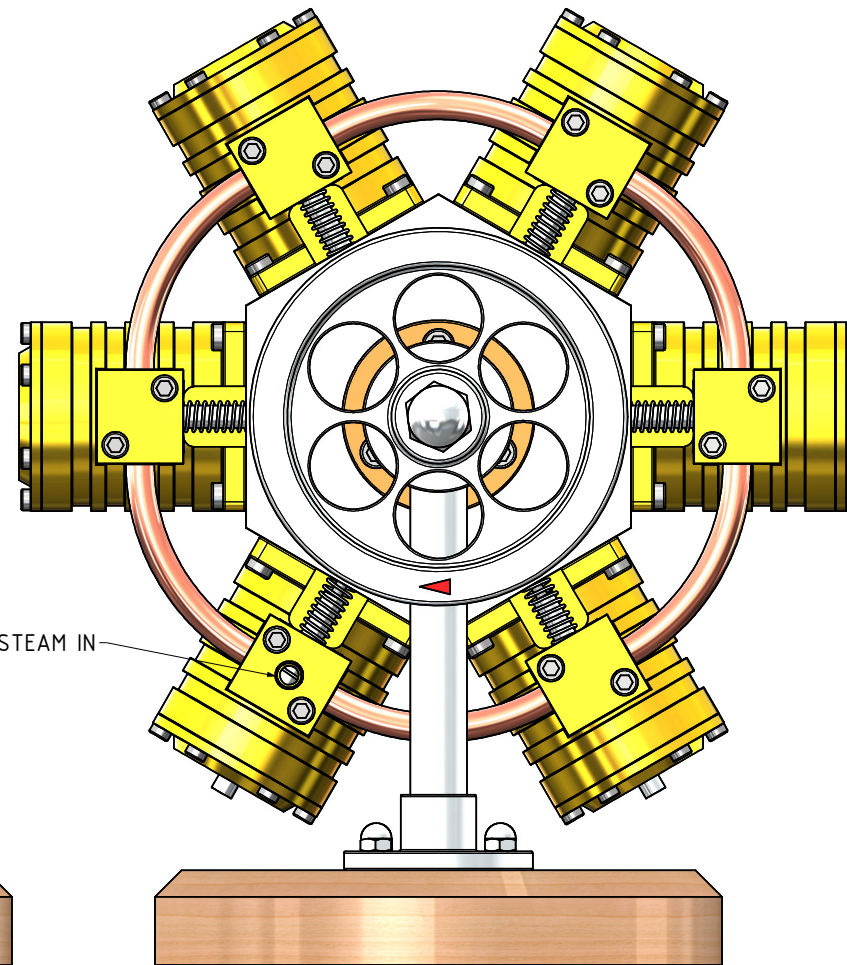

NOTES: THE DESIGN OF THIS ENGINE IS LOOSLY BASED ON THE DESIGN AND BUILT BY "CRUEBY". THE ORIGINAL DRAWINGS AND ARTICLE WERE GIVEN TO ME APPROXIMATELY 10 YEARS AGO. I HAVE MADE DESIGN CHANGES IN THE VALVING AND SCALED IT UP BY 2

TITLE
6 CYLINDER RADIAL STEAM ENGINE.
 (BORE=25mm STROKE=26mm)

DRAWING CONTENTS
GENERAL ARRANGEMENT, ISOMETRIC VIEW, NOTES, BILL OF MATERIALS

PROJECT No 09E-72-00
 JDW DRAUGHTING SERVICES
 J.A.M. DE WAAL, 12 BRIGHTWELL STREET PAPA KURA
 2110, NEW ZEALAND. PHONE: 0064 09 2988815. MOB: 0211791000 E-MAIL: dewaal@xtra.co.nz.

PROJECTION

 DATE JULY 2025
 SHEET: 01 OF 03

MODEL SCALE: 1:1
 DWG SCALE: 1:1 @A3 OR AS SHOWN
 Copyright © J.A.M. DE WAAL PAPA KURA NZ
A3 No:09E-72-00-SHT-01

DRAWINGS ARE FOR PERSONAL USE ONLY NOT FOR COMMERCIAL PURPOSES