

QTY	PART NUMBER
1	09A-39-00-1-01-BASE+STANDARD
1	09A-39-00-2-01-CRANKSHAFT+FLYWHEEL
1	09A-39-00-2-02-CYLINDER
1	09A-39-00-2-03-PISTON
1	09A-39-00-M3 NUT
1	09A-39-00-M3x9 A-K GRUB SCREW
4	09A-39-00-M6x18-ROUND HEAD WOOD SCREW
2	09A-39-00-M6x34 A-K C-SINK SCREW

THE DIRECTION OF ROTATION DEPENDS ON WHICH PORT IS USED FOR THE STEAM IN

- GENERAL NOTES:
- ALL DRAWINGS ARE IN METRIC MEASUREMENTS
 - ALL ENGINEERING PRACTICES SHALL BE APPLIED WITH REGARDS TO HOLE AND SHAFT TOLERANCES.
 - WHERE SCREWS OR BOLTS ARE USED THE CLEARANCE HOLES SHALL BE APPROXIMATELY 5% TO 8% LARGER THAN THE MATCHING TAPPED HOLE.
 - PREFERABLY ALL TAPPED HOLES AND MATCHING SCREWS AND/OR BOLTS TO BE METRIC FINE (MF)
 - MATERIALS SPECIFIED ON THE DRAWINGS ARE INDICATIVE ONLY. THE BUILDER CAN MAKE HIS/HER OWN MATERIAL CHOICE.
 - ALL CONNECTIONS/JOINTS WHICH HAVE STEAM PRESSURE APPLIED TO IT SHALL BE SILVER/HARD SOLDERED.
 - COMPRESSION SPRINGS ARE DRAWN IN COMPRESSED STATE (CP), UNCOMPRESSED STATE IS APPROX 40% TO 60% LONGER THEN COMPRESSED STATE.
 - WHERE PREFERRED SCREW OR RIVETED CONNECTIONS CAN BE OMITTED AND PARTS CAN BE BONDED TOGETHER BY USING EITHER HIGH STRENGTH GLUE, EPOXY RESIN, OR SOLDER.
 - PARTS WHICH ARE DIRECTLY EXPOSED TO STEAM AND/OR WATER SHOULD BE CONSTRUCTED USING NON-FERROUS OR NON CORROSIVE MATERIAL SUCH AS BRASS, BRONZE, GUNMETAL, STAINLESS STEEL, COPPER OR MONEL.
 - THE ORDER IN WHICH THE PARTS/COMPONENTS ARE MANUFACTURED AND THE MODEL IS ASSEMBLED IS ENTIRELY LEFT TO THE BUILDER/MODEL MAKER.
 - A COLOUR SCHEME FOR THIS PROJECT IS ENTIRELY LEFT UP TO THE MODEL MAKER.
 - THE MANNER IN WHICH THE PARTS/COMPONENTS ARE MANUFACTURED IS ENTIRELY LEFT UP TO THE BUILDER.
 - USE LOCTITE, ON SCREW OR PRESS FIT CONNECTIONS OR SURFACES, WERE DEEMED NECESSARY TO PREVENT PARTS FROM LOOSENING.
 - WASHERS AND/OR SPRING WASHERS SHALL BE USED WHERE DEEMED NECESSARY.
 - REMOVE ALL SHARP EDGES
 - XX. ERRORS AND/OR OMISSIONS MAY OCCUR IN THE DRAWINGS, DO NOT HESITATE TO CONTACT ME SO THAT THE ERRORS/OMISSIONS CAN BE RECTIFIED.

DUE TO THE LACK OF INFORMATION ON THE ORIGINAL DRAWING(S), SUCH AS VIEWS, DIMENSIONS, SECTIONS ETC AND/OR CLARITY OF COMPONENTS, OMITTED PARTS/COMPONENTS, SOME OF THE COMPONENTS MIGHT NOT BE AS CONSTRUCTED ORIGINALLY OR AS THE ORIGINAL DESIGNER INTENDED

- OTHER ABBREVIATIONS
- AS = AS SHOWN
 - DP = DEEP
 - DAA= DRILL AFTER ASSEMBLY
 - D&TAA= DRILL AND TAP AFTER ASSEMBLY
 - CF = CLOSE FIT (SIZE FOR SIZE)
 - PF = PRESS FIT
 - PFAA= PRESS FIT AFTER ASSEMBLY
 - PCD = PITCH CIRCLE DIAMETER
 - RM = REAM
 - HEX = HEXACON, 6SIDED
 - CP = COMPRESSED
 - KNL = KNURLED
 - CSK = COUNTERSINK
 - PL = PLACES
 - DWL= DOWEL
 - SPF= SPOTFACE
 - (T)HESOP=(TAPPED)HOLES EQUALLY SPACED ON CIRCUMFERENCE
 - (T)HESOC=(TAPPED)HOLES EQUALLY SPACED ON CIRCUMFERENCE
 - OD = OUTSIDE DIAMETER
 - ID = INSIDE DIAMETER
 - MAX/MIN = CRITICAL DIMENSION
 - SA-xxx= SUB ASSEMBLY-xxx
- MATERIAL ABBREVIATIONS:
- ALU = ALUMINIUM
 - HALU= HARD ALUMINIUM
 - BRS = BRASS
 - BRZ = BRONZE OR GUNMETAL (BRZ/GM)
 - CI = CAST IRON
 - CU = COPPER
 - GRA = GRAPHITE
 - MS = MILD STEEL/BRIGHT MILD STEEL
 - SS = SILVER STEEL OR STAINLESS STEEL
 - SPS = SPRING STEEL
 - PEEK= POLYETHER ETHER KETONE
 - SYN = SYNTHETIC MATERIAL SUCH AS VETON, NYLON, TEFLON OR RUBBER
- IN GENERAL SYNTHETIC MATERIALS SHOULD BE ABLE TO WITHSTAND THE HEAT AND PRESSURE(S) APPLIED TO THEM.
- nnn/nnn MEANS THAT EITHER MATERIAL CAN BE USED

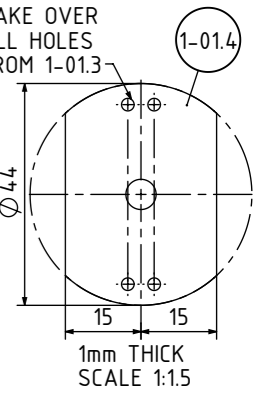
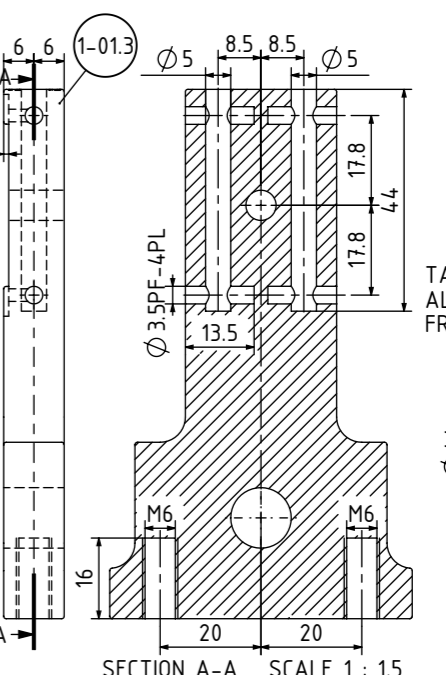
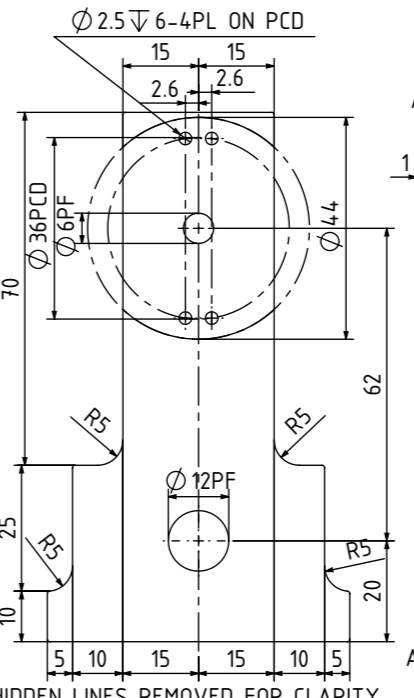
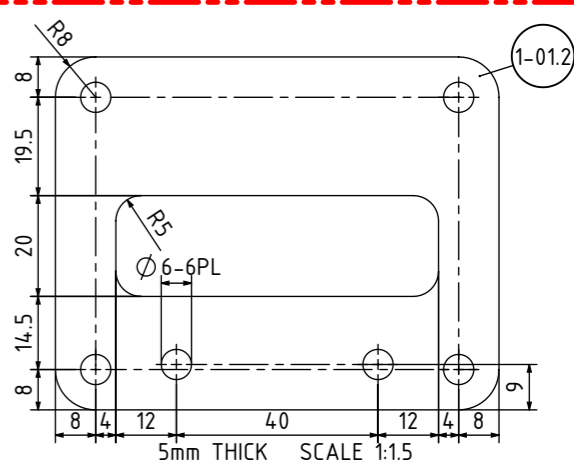
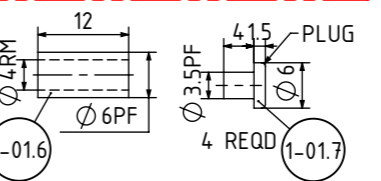
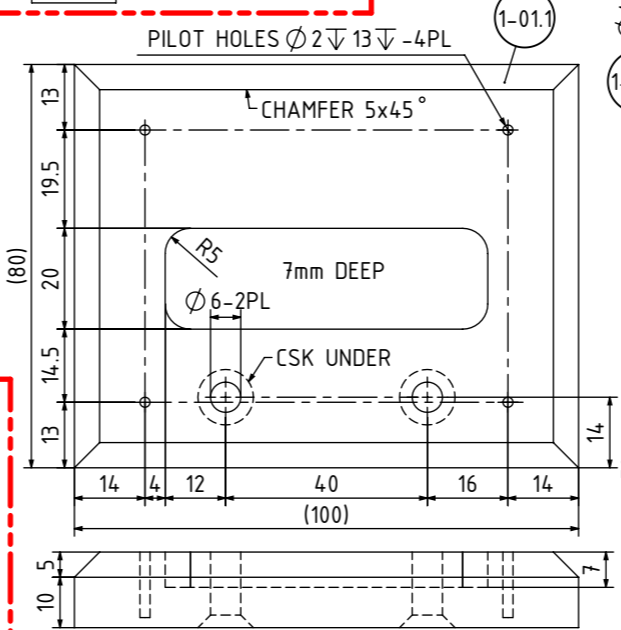
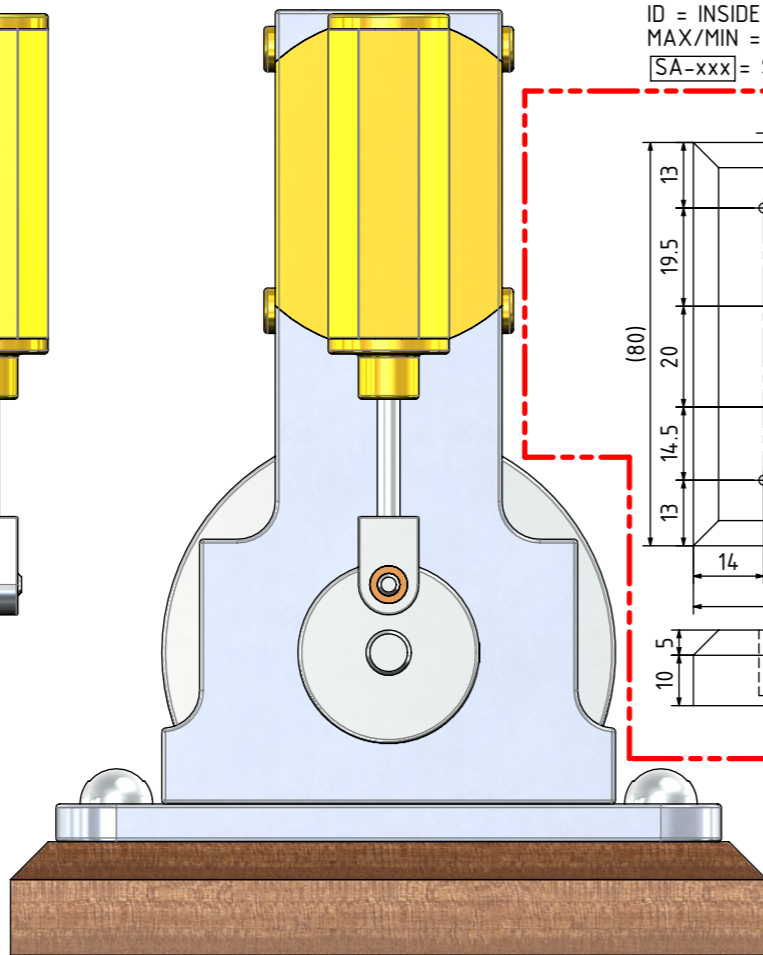
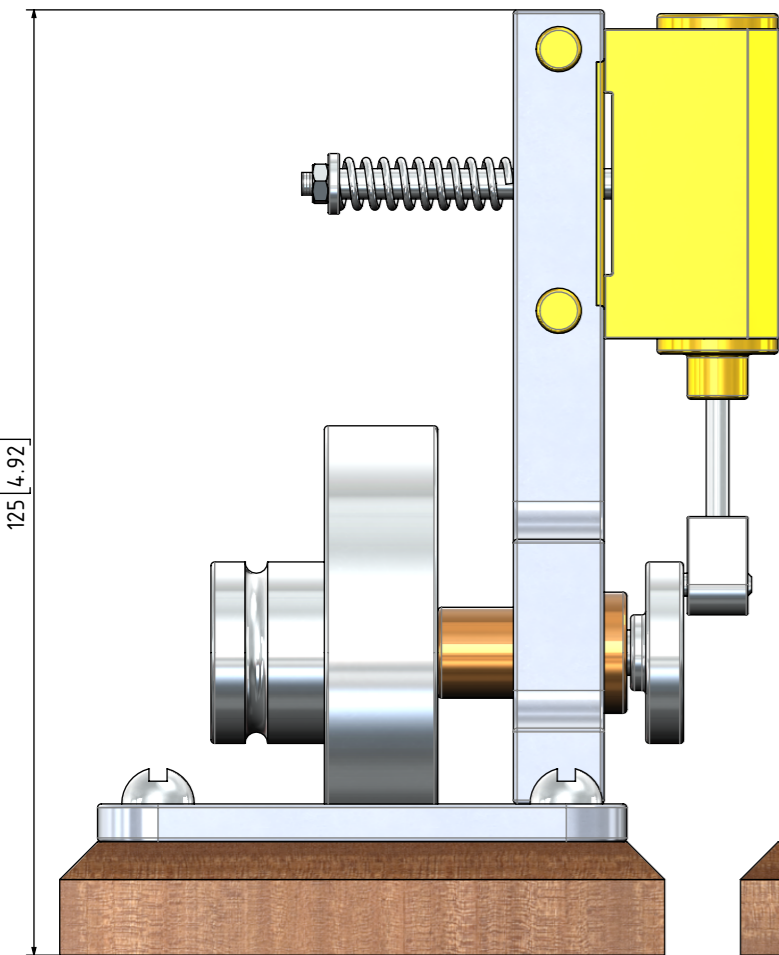
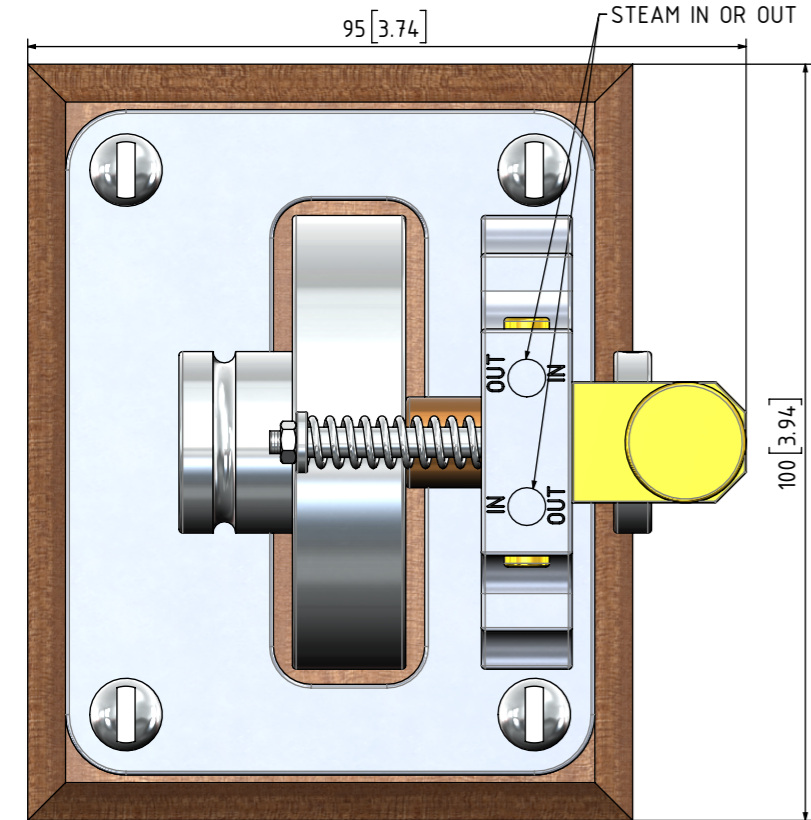
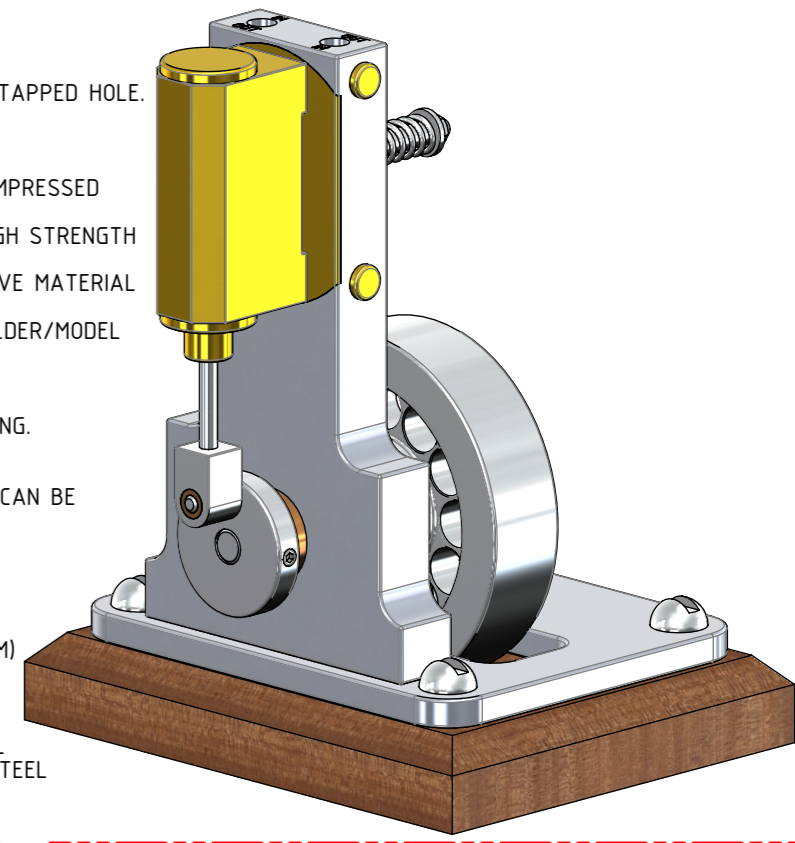

NOTES: THE ORIGINAL DRAWINGS WERE GIVEN TO ME. THE ORIGINAL DESIGN AND DRAWING WERE MADE BY ERIK-JAN STROETINGA, EINDHOVEN, THE NETHERLANDS AND DATED SEPTEMBER 1998. (E.J. STROETINGA@FONTSY.NL). MY DRAWINGS HAS SLIGHT ALTERATIONS INCORPORATED.

TITLE
A 1 CYLINDER VERTICAL OSCILLATING STEAM ENGINE (BORE=10mm STROKE=18mm)

DRAWING CONTENTS
G.A., ISOMETRIC VIEW, NOTES, BOM, PARTS AND ASSEMBLIES

PROJECT No 09A-39-00
 JDW DRAUGHTING SERVICES
 J.A.M. DE WAAL, 12 BRIGHTWELL STREET PAPAOKURA
 2110, NEW ZEALAND. PHONE: 0064 09 2988815. MOB: 0211791000 E-MAIL: dewaal@xtra.co.nz.

PROJECTION
JDWDS
 DATE: DECEMBER 2024
 SHEET: 01 OF 02

MODEL SCALE: 1:1
 DWG SCALE: 1:1 @A3 OR AS SHOWN
 Copyright © J.A.M. DE WAAL PAPAOKURA NZ
A3 No:09A-39-00-SHT-01