

QTY.	PART NUMBER
1	09E-66-01-1-01-BASE STRUCTURE-FRAME
1	09E-66-01-1-02-CYLINDER
1	09E-66-01-1-03-CYLINDER TOP COVER+CROSSHEAD GUIDE
2	09E-66-01-1-04-MAIN BEARING
2	09E-66-01-1-05-EXHAUST NIPPLE
1	09E-66-01-2-01-CRANKSHAFT+FLYWHEEL
1	09E-66-01-2-02-PISTON+CROSSHEAD
1	09E-66-01-2-03-CON-ROD
1	09E-66-01-2-04-VALVE ROCKING SHAFT
1	09E-66-01-2-05-ECCENTRIC SHEAVE
1	09E-66-01-2-06-ECCENTRIC STRAP
1	09E-66-01-2-07-SLIDE VALE+CROSSHEAD
1	09E-66-01-2-08-VALVE CONNECTING RODS
1	09E-66-01-2-09-GOVERNOR MAIN SPINDLE
1	09E-66-01-2-10-GOVERNOR CONTROL SHEAVE
1	09E-66-01-2-11-GOVERNOR CONTROL ROCKING SPINDLE
1	09E-66-01-2-12-GOVERNOR CONTROL SHEAVE FINGER
4	09E-66-01-2-13-GOVERNOR FLYWEIGHT RESTRAINER
2	09E-66-01-2-14-SWING ARM+FLYWEIGHT
1	09E-66-01-2-15-STEAM CONTROL FLAP
1	09E-66-01-2-16-STEAM CONTROL CON-ROD
1	09E-66-01-2-17-DRIVING BELT
12	09E-66-01-M2 NUT
3	09E-66-01-M2.5x2 A-K GRUB SCREW
1	09E-66-01-M2.5x5 A-K GRUB SCREW
9	09E-66-01-M3 DOME NUT
4	09E-66-01-M3 NUT
8	09E-66-01-M3x10 A-K CYL HEAD SCREW
4	09E-66-01-M3x12 A-K C-SINK SCREW
4	09E-66-01-M3x18 A-K CYL HEAD SCREW
1	09E-66-01-M3x19 A-K C-SINK SCREW
6	09E-66-01-M3x8 A-K CYL HEAD SCREW
4	09E-66-01-M4 DOME NUT
3	09E-66-01-M4 NUT
3	09E-66-01-M4 WASHER
4	09E-66-01-M4x10 A-K CYL HEAD SCREW
8	09E-66-01-M4x12 A-K CYL HEAD SCREW
1	09E-66-01-M4x4.5 A-K CYL HEAD SCREW
2	09E-66-01-M4x5.5 A-K GRUB SCREW
2	09E-66-01-M4x6 A-K CYL HEAD SCREW
3	09E-66-01-M5 DOME NUT
8	09E-66-01-M5 NUT
4	09E-66-01-M6 DOME NUT
2	09E-66-01-M6x16 A-K C-SINK SCREW
2	09E-66-01-M6x20 A-K C-SINK SCREW

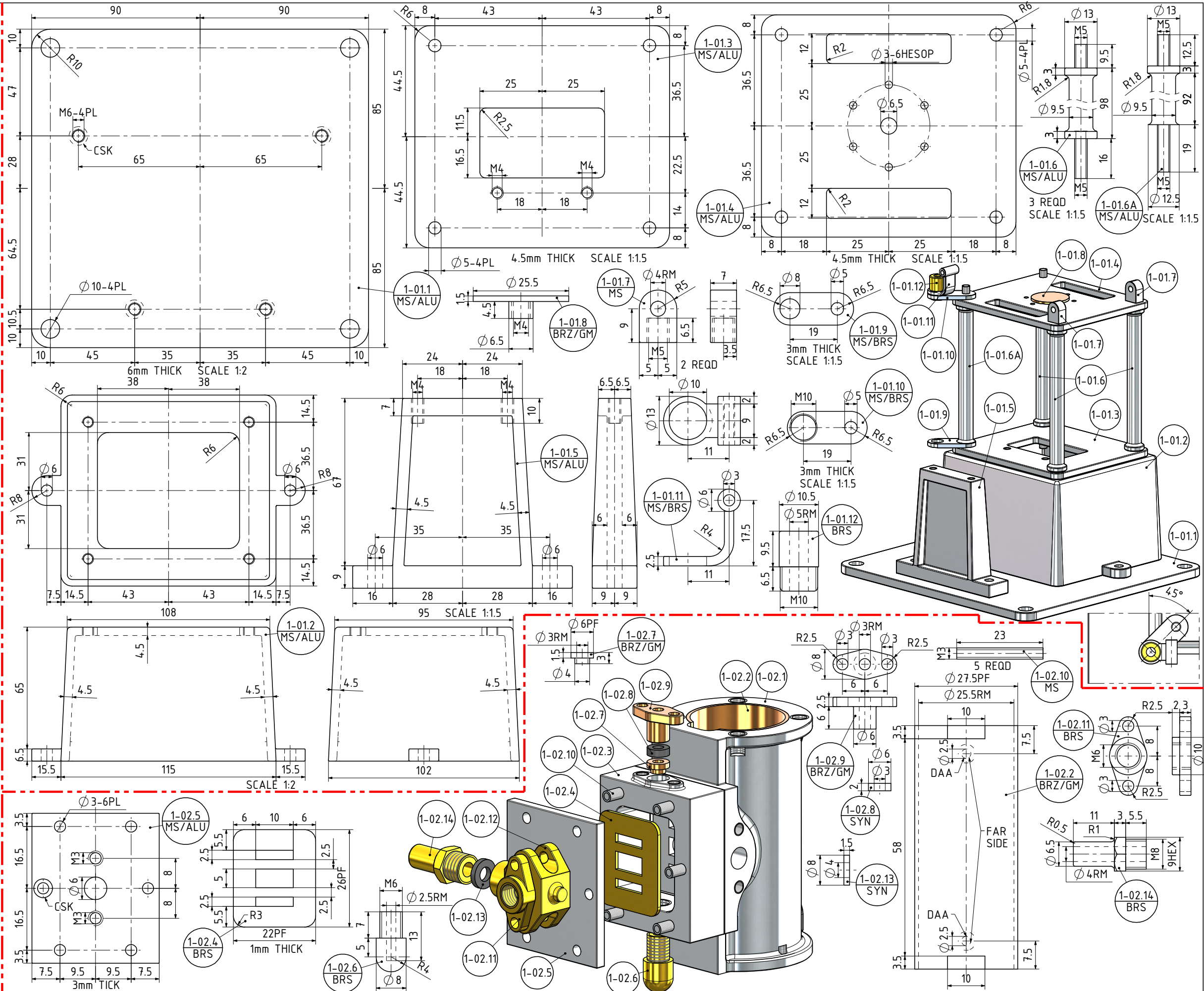
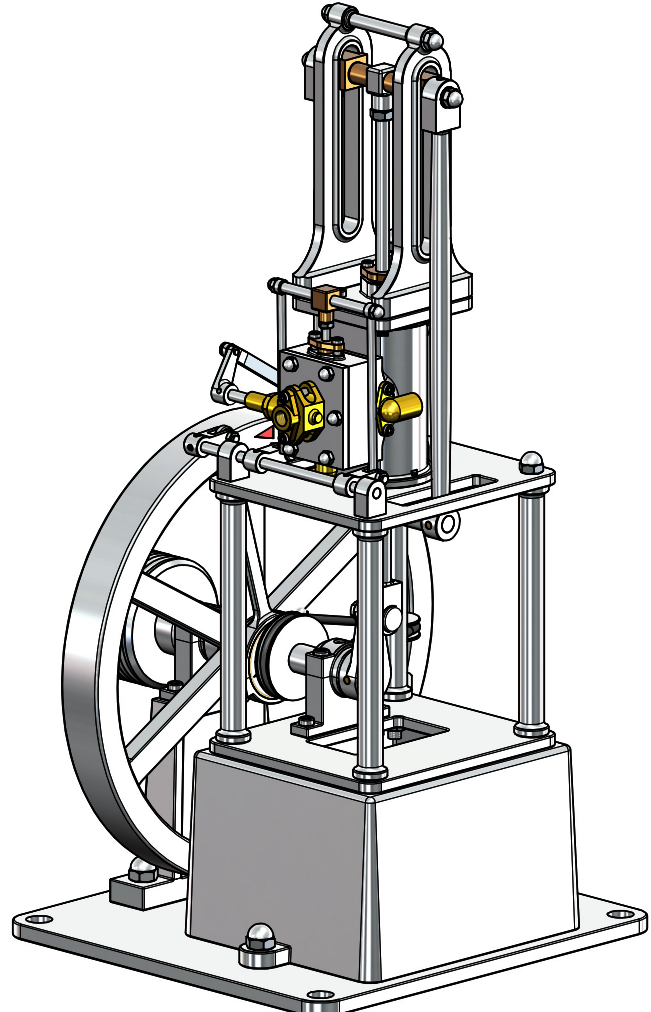

NOTES: THE ORIGINAL DRAWINGS WERE GIVEN TO ME. THE ORIGINAL DRAWINGS WERE B STUART TURNER LTD HENLEY ON THAMES. DRG No 90086, TITLE: "THE JAMES COOMBS TABLE ENGINE" DRAWN BY R. G. PENDER? GOVERNOR DRAWING No: 90104 DRAWN BY P.R.M. DATED 15.4.81

TITLE
1 CYL. VERT. N.R. STEAM ENGINE "JAMES COOMBS TABLE ENGINE" WITH GOVERNOR

DRAWING CONTENTS
ISOMETRIC VIEW, BILL OF MATERIALS PARTS AND ASSEMBLIES

PROJECT No 09E-66-01
 JDW DRAUGHTING SERVICES
 J.A.M. DE WAAL, 12 BRIGHTWELL STREET PAPAOKURA
 2110, NEW ZEALAND. PHONE: 0064 09 2988815. MOB: 0211791000 E-MAIL: dewaal@xtra.co.nz.

PROJECTION
JDWDS
 DATE APRIL 2025
 SHEET: 02 OF 05
 MODEL SCALE: 1:1
 DWG SCALE: 1:1 @A3 OR AS SHOWN
 Copyright © J.A.M. DE WAAL PAPAOKURA NZ
A3 No:09E-66-01-SHT-02

DRAWINGS ARE FOR PERSONAL USE ONLY NOT FOR COMMERCIAL PURPOSES