

- NOTES:
0. ALL DRAWINGS ARE IN METRIC MEASUREMENTS
 1. ALL ENGINEERING PRACTICES SHALL BE APPLIED WITH REGARDS TO HOLE AND SHAFT TOLERANCES.
 2. WHERE SCREWS OR BOLTS ARE USED THE CLEARANCE HOLES SHALL BE APPROXIMATELY 5% TO 8% LARGER THAN THE MATCHING TAPPED HOLE.
 3. PREFERABLY ALL TAPPED HOLES AND MATCHING SCREWS AND/OR BOLTS TO BE METRIC FINE (MF)
 4. MATERIALS SPECIFIED ON THE DRAWINGS ARE INDICATIVE ONLY. THE BUILDER CAN MAKE HIS/HER OWN MATERIAL CHOICE.
 5. ALL CONNECTIONS/JOINTS WHICH HAVE STEAM PRESSURE APPLIED TO IT SHALL BE SILVER/HARD SOLDERED.
 6. COMPRESSION SPRINGS ARE DRAWN IN COMPRESSED STATE (CP), UNCOMPRESSED STATE IS APPROX 40% TO 60% LONGER THEN COMPRESSED STATE.
 7. WHERE PREFERRED SCREW OR RIVETED CONNECTIONS CAN BE OMITTED AND PARTS CAN BE BONDED TOGETHER BY USING EITHER HIGH STRENGTH GLUE, EPOXY RESIN, OR SOLDER.
 8. PARTS WHICH ARE DIRECTLY EXPOSED TO STEAM AND/OR WATER SHOULD BE CONSTRUCTED USING NON-FERROUS OR NON CORROSIVE MATERIAL SUCH AS BRASS, BRONZE, GUNMETAL, STAINLESS STEEL, COPPER OR MONEL.
 9. THE ORDER IN WHICH THE PARTS/COMPONENTS ARE MANUFACTURED AND THE MODEL IS ASSEMBLED IS ENTIRELY LEFT TO THE BUILDER/MODEL MAKER.
 10. A COLOUR SCHEME FOR THIS PROJECT IS ENTIRELY LEFT UP TO THE MODEL MAKER.
 11. THE MANNER IN WHICH THE PARTS/COMPONENTS ARE MANUFACTURED IS ENTIRELY LEFT UP TO THE BUILDER.
 12. USE LOCTITE, ON SCREW OR PRESS FIT CONNECTIONS OR SURFACES, WERE DEEMED NECESSARY TO PREVENT PARTS FROM LOOSENING.
 13. WASHERS AND/OR SPRINGWASHERS SHALL BE USED WHERE DEEMED NECESSARY.
 - XX. ERRORS AND/OR OMISSIONS MAY OCCUR IN THE DRAWINGS, DO NOT HESITATE TO CONTACT ME SO THAT THE ERRORS/OMISSIONS CAN BE RECTIFIED.

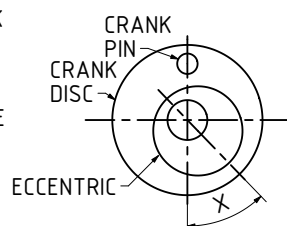

THE OFF SET ANGLE OF THE ECCENTRIC IN RELATION TO THE CRANK AXIS TO BE EXPERIMENTALLY DETERMINED FOR THE SMOOTH RUNNING OF THE ENGINE AND SATISFACTION OF THE BUILDER

MATERIAL ABBREVIATIONS:

- ALU = ALUMINIUM
- HALU= HARD ALUMINIUM
- BRS = BRASS
- BRZ = BRONZE OR GUNMETAL (BRZ/GM)
- CI = CAST IRON
- CU = COPPER
- GRA = GRAPHITE
- MS = MILD STEEL/BRIGHT MILD STEEL
- SS = SILVER STEEL OR STAINLESS STEEL
- SPS = SPRING STEEL
- PEEK= POLYETHER ETHER KETONE
- SYN = SYNTHETIC MATERIAL SUCH AS VETON, NYLON, TEFLON OR RUBBER

IN GENERAL SYNTHETIC MATERIALS SOULD BE ABLE TO WITHSTAND THE HEAT AND PRESSURE(S) APPLIED TO THEM.
nnn/nnn MEANS THAT EITHER MATERIAL CAN BE USED

- OTHER ABBREVIATIONS
- DP = DEEP
 - DAA= DRILL AFTER ASSEMBLY
 - D&TAA= DRILL AND TAP AFTER ASSEMBLY
 - CF = CLOSE FIT (SIZE FOR SIZE)
 - PF = PRESS FIT
 - PFAA= PRESS FIT AFTER ASSEMBLY
 - PCD = PITCH CIRCLE DIAMETER
 - RM = REAM
 - HEX = HEXACON, 6SIDED
 - CP = COMPRESSED
 - KNL = KNURLED
 - CSK = COUNTERSINK
 - PL = PLACES
 - DWL= DOWEL
 - SPF= SPOTFACE
 - (T)HESOP=(TAPPED)HOLES EQUALLY SPACED ON PCD
 - (T)HESOC=(TAPPED)HOLES EQUALLY SPACED ON CIRCUMFERENCE
 - OD = OUTSIDE DIAMETER
 - ID = INSIDE DIAMETER
 - [SA-xxx]= SUB ASSEMBLY-xxx

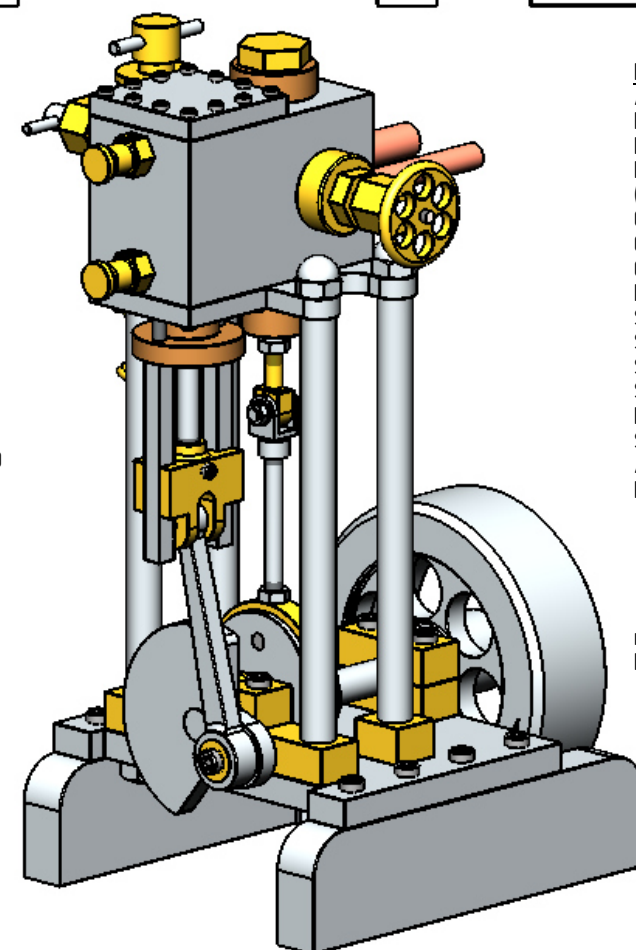

QTY.	PART NUMBER
1	09C-41-00-1-01-BASE PLATE
1	09C-41-00-1-02-COLUMN+PLATFORM
1	09C-41-00-1-03-CYLINDER BLOCK
1	09C-41-00-1-04-VALVE CHAMBER
2	09C-41-00-1-05-CYLINDER DRAIN COCK
1	09C-41-00-1-06-STEAM SUPPLY VALVE
1	09C-41-00-1-07-DISPLACEMENT LUBRICATOR
1	09C-41-00-2-01-CRANK SHAFT+FLYWHEEL
1	09C-41-00-2-02-PISTON+CROSSHEAD
1	09C-41-00-2-03-CON-ROD
1	09C-41-00-2-04-SPOOL VALVE
1	09C-41-00-2-05-ECCENTRIC SHEAVE
1	09C-41-00-2-06-ECCENTRIC STRAP
1	09C-41-00-M2.5 NUT
13	09C-41-00-M2.5x14 A-K CYL HEAD SCREW
1	09C-41-00-M2.5x5.5 A-K GRUB SCREW
2	09C-41-00-M3 NUT
2	09C-41-00-M3 WASHER-BRASS
6	09C-41-00-M3x20 A-K CYL HEAD SCREW
2	09C-41-00-M3x5 A-K GRUB SCREW
2	09C-41-00-M4 NUT
1	09C-41-00-M4 WASHER-BRASS
1	09C-41-00-M4x10 A-K C-SINK SCREW
1	09C-41-00-M4x12 A-K CYL HEAD SCREW
8	09C-41-00-M4x16 A-K CYL HEAD SCREW
4	09C-41-00-M4x24 A-K CYL HEAD SCREW
4	09C-41-00-M6 DOME NUT
4	09C-41-00-M6 NUT

NOTES: THIS DESIGN IS BASED ON DRAWINGS WHICH WERE GIVEN TO ME. THE ORIGINAL DESIGN AND DRAWINGS WERE BY C.W.WOODSON. THE ORIGINAL DRAWINGS WERE PUBLISHED IN "MECHANIX ILLUSTRATED" MAGAZINE, DATED OCTOBER 1944 PAGES: 83 TO89, 132, 142 AND 144

TITLE
A SIMPLE SINGLE CYLINDER VERTICAL STEAM ENGINE FOR BEGINNERS (B=24mm ST=28mm)

DRAWING CONTENTS
GENERAL ARRANGEMENT, ISOMETRIC VIEW, BILL OF MATERIALS, NOTES

PROJECT No 09C-41-00
JDW DRAUGHTING SERVICES
J.A.M. DE WAAL, 12 BRIGHTWELL STREET PAPAOKURA
2110, NEW ZEALAND. PHONE: 0064 09 2988815. MOB:
0211791000 E-MAIL: dewaal@xtra.co.nz.

PROJECTION
DATE NOVEMBER 2019
SHEET: 01 OF 03

MODEL SCALE: 1:1
DWG SCALE: 1:1 @A3 OR AS SHOWN
Copyright © J.A.M. DE WAAL PAPAOKURA NZ
A3 No: 09C-41-00-SHT01