

# BACKWOODS MINIATURES

11 NETHERTON SOUTHSIDE, NETHERTON, MORPETH, NE65 7EZ, ENGLAND

Telephone: (01669) 630255, Fax: (01669) 630260 \*

e-mail: [sales@backwoodsminiatures.com](mailto:sales@backwoodsminiatures.com)

website: [www.backwoodsminiatures.com](http://www.backwoodsminiatures.com)

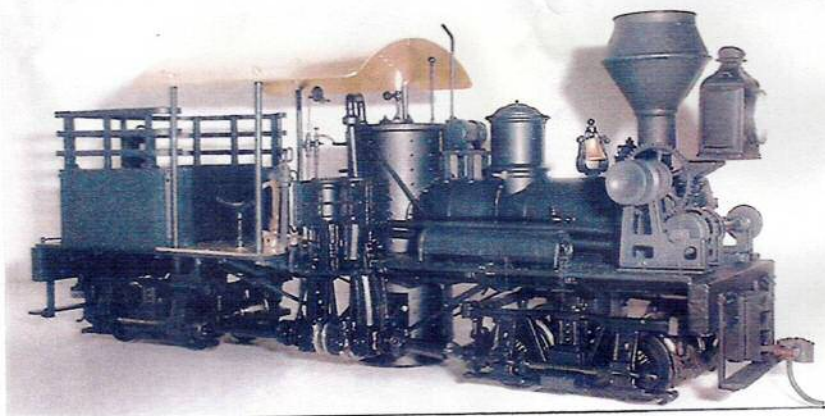
\*If calling from abroad - delete '0' from area code

## UPGRADE/DETAILING KIT FOR BACHMANN'S 0n30 T-BOILER TWO TRUCK SHAY LOCO

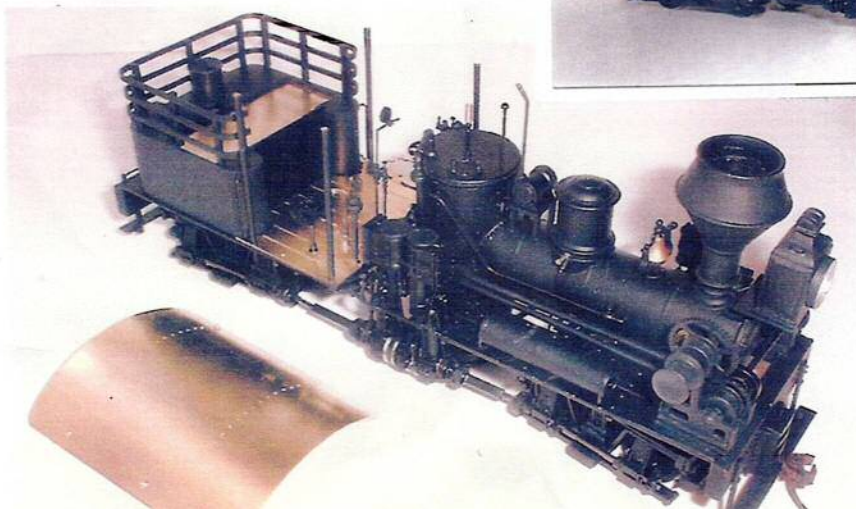


PHOTO SHOWS WOOD-STYLE  
ROOF CUT FROM EXISTING  
BACHMANN CAB CASTING.

PHOTO SHOWS ALTERNATIVE  
PRE-ROLLED ETCHED ROOF.  
NOTE: PHOTO'S DO NOT  
SHOW PIPING/PLUMBING  
INSTALLED.



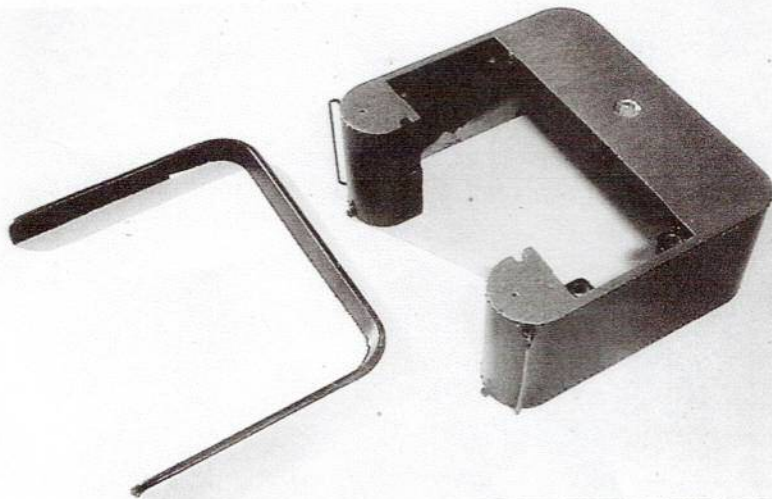
ETCHED ROOF REMOVED  
TO SHOW SOME OF THE  
OTHER DETAILS SUCH AS  
THE CAB FLOOR AND  
BUNKER BLANKING PLATE.



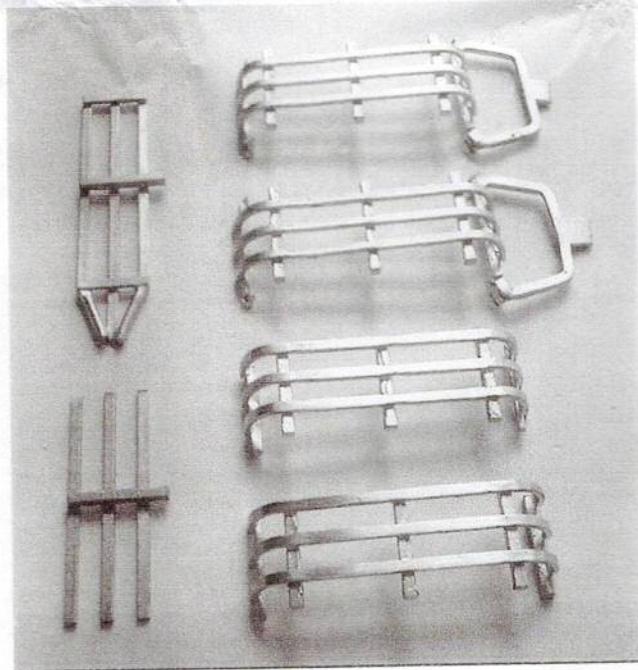
## **BUNKER ALTERATIONS**

Our upgrade kit provides for an alternative fuel bunker style much more in keeping with open-cab variants. Bachmann's excellent die-cast bunker is easily modified as shown in the photos.

Carefully remove the handwheels from the top front of the bunker.



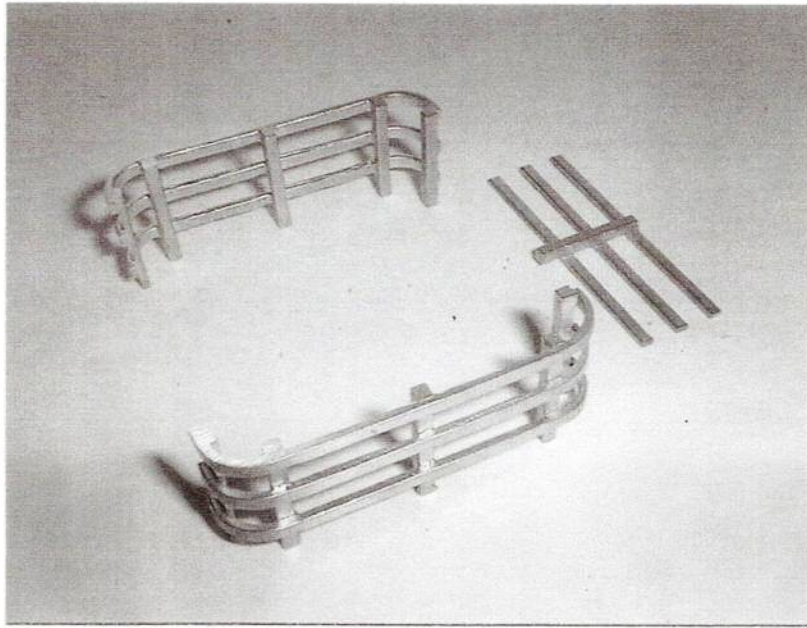
Remove the bunker's flared top and water filler. We easily removed these with a junior hacksaw. Grip the bunker gently in a vice and cut slowly, ensuring the saw blade does not wander beyond the flare and into the main bunker area. Aim to leave approximately 0.5mm of flare and water filler material still attached. This material is easily removed by inverting the bunker and rubbing the top face on abrasive paper till the top is truly flat. Photo shows the flare removed and the bunker top smoothed flush as described. Drill a hole using a 2.6mm bit to locate the new, taller water filler casting.



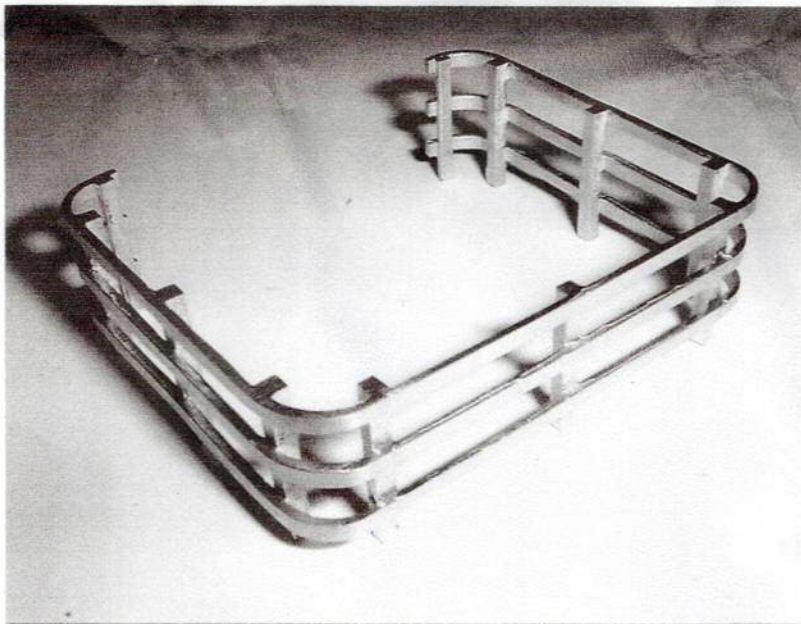
New cast brass bunker rails are provided. The rails assemble from three parts: left and right side rails and a rear rail.

As supplied; the castings for the side rails are identical and it will be necessary to prepare left and right handed rails from these. Remove feed sprues as shown.

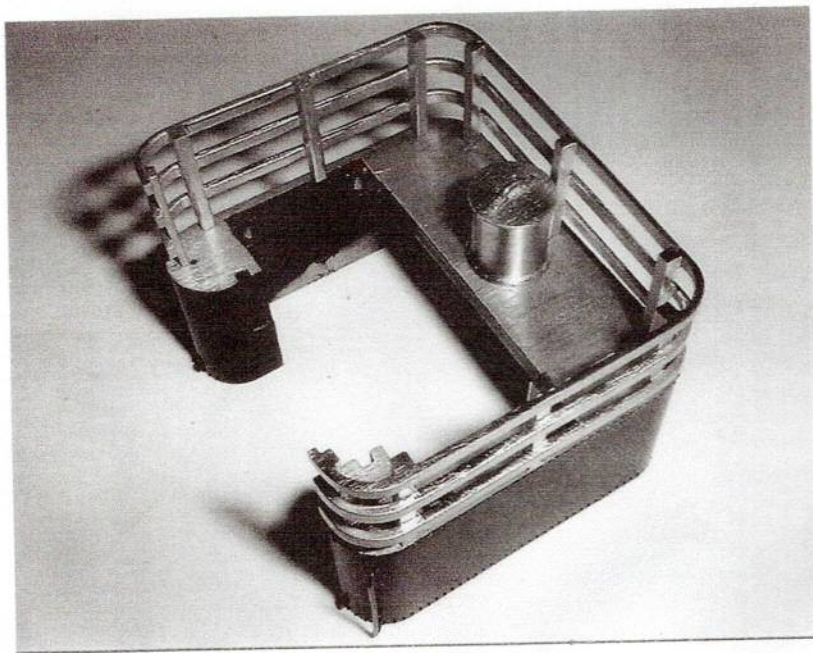
Photo shows the castings as supplied with the prepared rails beneath. Note that it is necessary to trim the vertical uprights of the side rails flush with the top edge of the horizontal rails to produce left and right handed units. The horizontal rear rails should be trimmed to exactly 33.5mm length to fit accurately between the left and right side rails.



*The fully prepared bunker rails prior to assembly into a single unit. Note that the ends of the rear rails locate against the rear uprights so they align with the side rails.*



*The assembled bunker rails, showing clearly the neatly formed joint between the side and rear rail castings. We much prefer the strength and neatness of solder to assemble such a unit, however, you may opt for adhesive. Gently rub the top surface of the rails and the bottom of the vertical uprights on abrasive paper to ensure the assembly sits level.*



The assembled rails in place on the bunker top. Epoxy or ACC adhesive is used to secure the rails. Similarly attach the water filler to its hole in the bunker top.

An etched blanking plate fills the large cavity in the fuel space. This butts against the moulded plastic panel (ref 00S03, 00S04 or 00S06) supplied with the Shay and which slots into place on the bunker front.

We advise filling the original holes for the bunker top handwheels and drilling new holes 2mm further back. The handwheels can then be refitted without fouling the bunker rails.

A water feed pipe, bent up from brass wire, locates into the hole provided in the etched blanking plate. This terminates by butting against the cab floor.

A shovel and stowage boxes are included. These boxes are intended to fit inside the bunker rails, one per side. Fit these prior to adding the coal or wood fuel load.

The new bunker is designed to be filled with a coal or cut wood fuel load. Admirable though Bachmann's provided fuel loads are, they are not on a par with either a hand-poured coal load or hand-cut wood load. We advise adding such a load and securing it in place with watered-down wood glue after the bunker assembly has been painted.

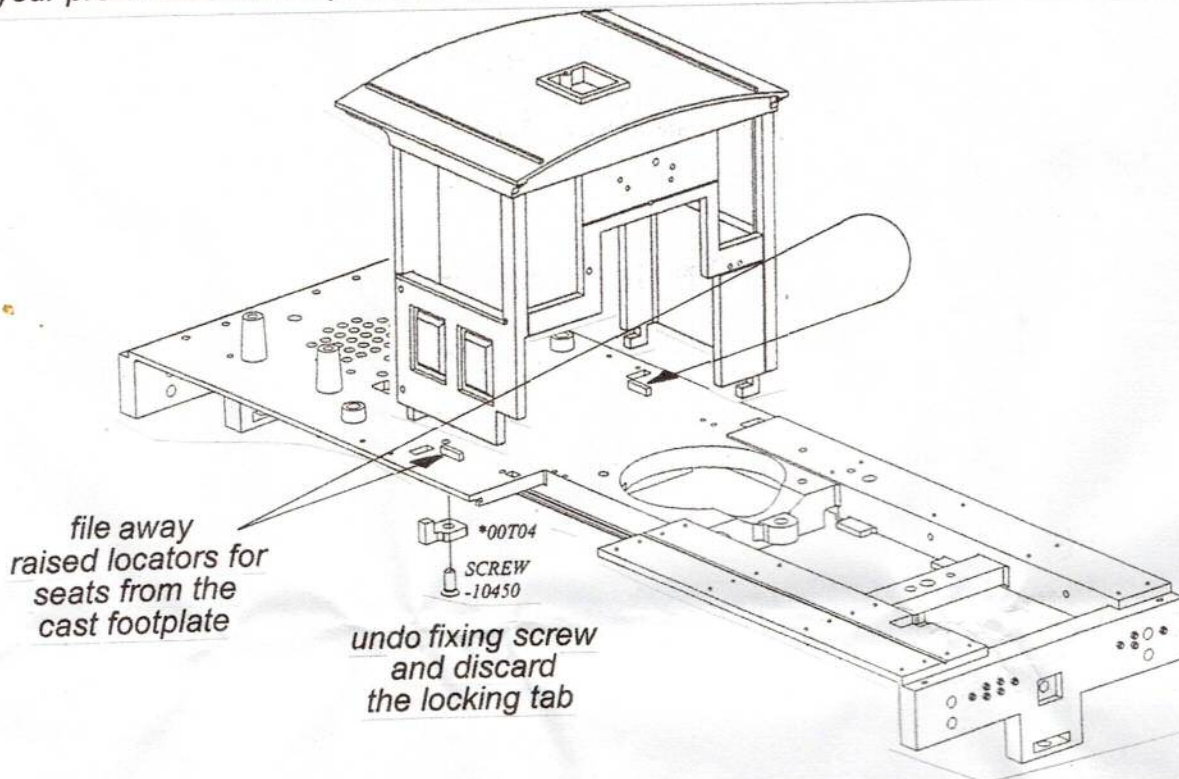


etched blanking plate

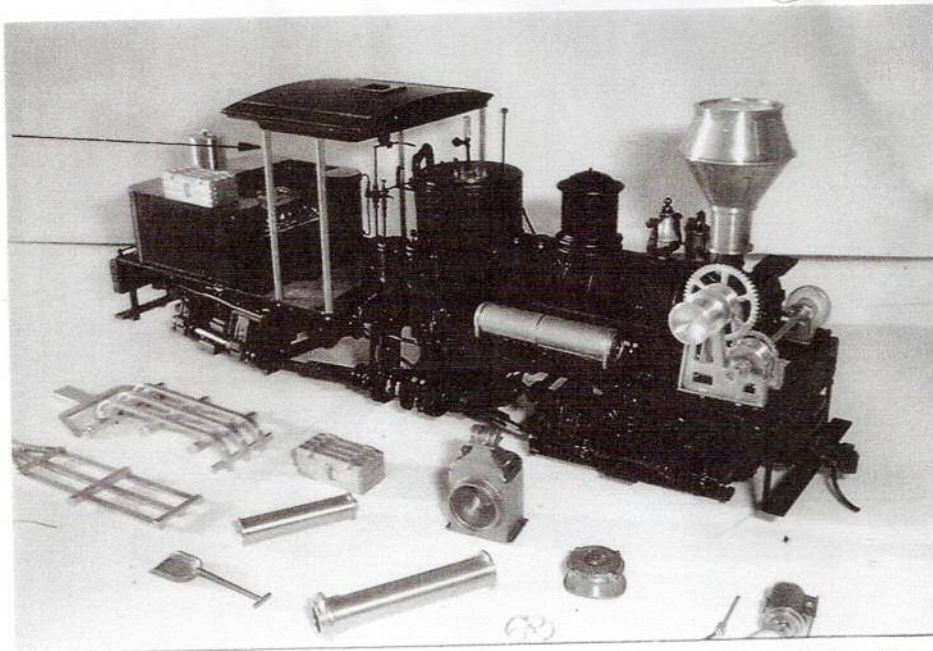
## OPEN CAB

This conversion depends upon removal of the Shay's original cab. This involves carefully un-plugging or cutting the moulded piping entering the cab front. Remove the cab by undoing the fixing screw and discarding the locking tab (part ref 00T04 on page 2 of Bachmann's exploded drawings) which allows the cab to be slid slightly sideways and lifted clear. Remove the brake column and moulded seats. It will be necessary to file away the raised locators for the seats from the cast footplate.

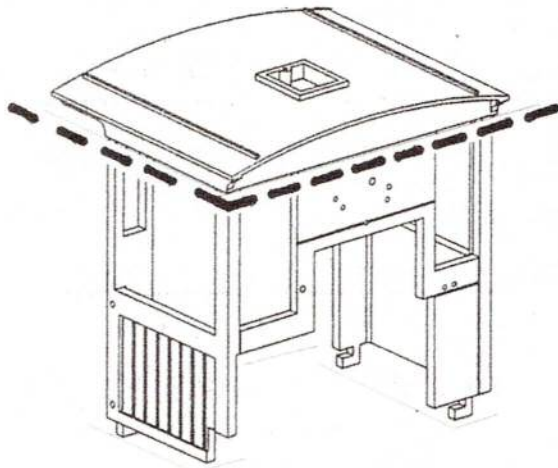
Our conversion includes parts for open cab versions. Two styles are provided, an etched sheet metal roof or a wood-type roof cut from Bachmann's original diecast cab. Select your preference before proceeding.



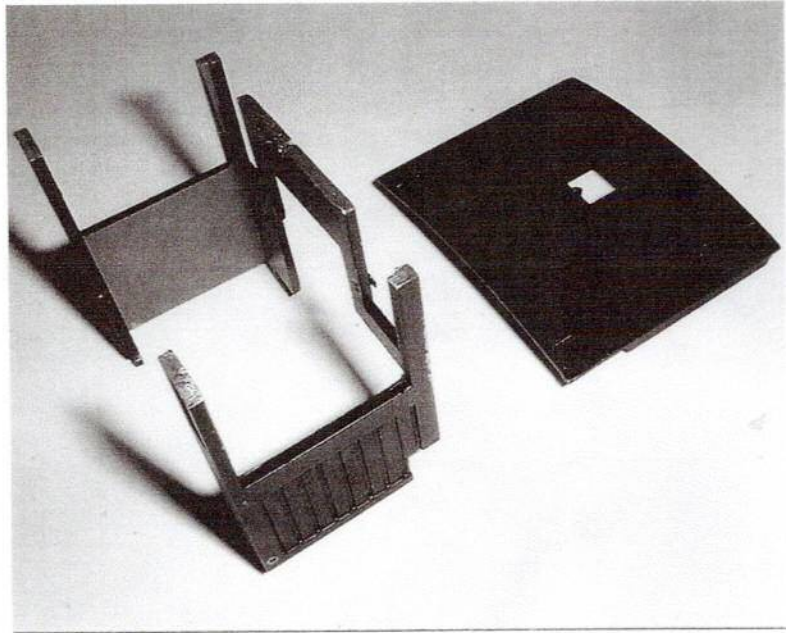
cut x 4  
cab uprights  
to 37mm  
length from  
small-bore  
brass tube  
supplied



Either roof style is supported on vertical lengths of small bore brass tube, the roof being secured to the uprights using short lengths of brass wire to pin it in place. The pre-rolled etched roof has the necessary holes for wire pins pre-etched in the correct position: These holes correspond with certain holes provided in the etched footplate panel. Check the diagram to see which holes in the footplate correspond with either roof variant.

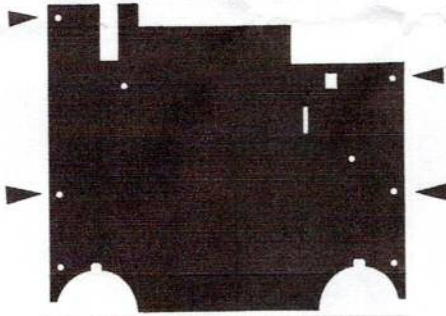


cut as shown

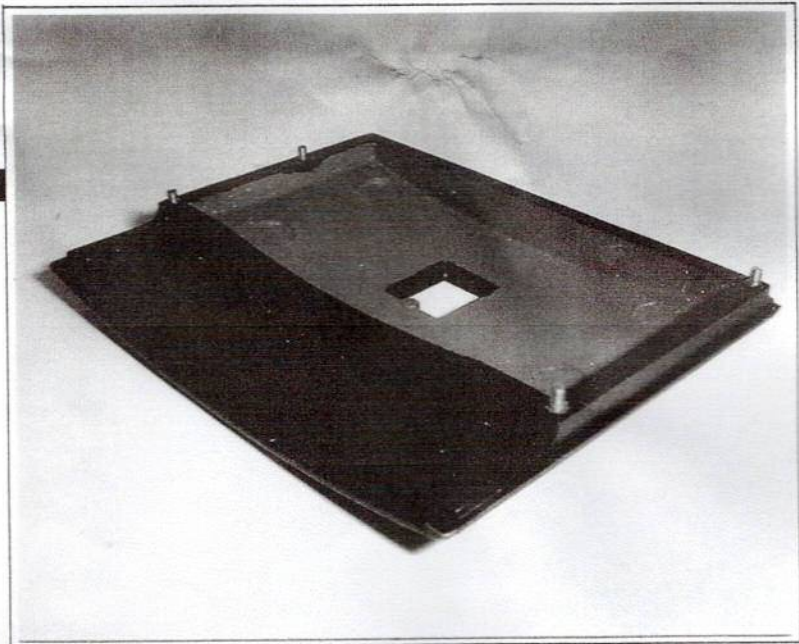
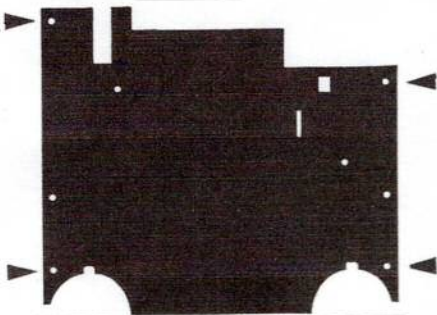


If you opt to use the wood-type roof, the necessary section must be cut from the one-piece diecast original. Only the roof/valance portion is required and this is easily cut away using a junior hacksaw or similar. Cut as close to the lower edge of the valance as possible. Discard the unwanted part of the cab (yard clutter, maybe?) and rub the underside of the roof section on abrasive paper until truly flush with the lower edge of the valance. The photo and diagram illustrate what's required.

use these holes for uprights  
with wood-style roof



use these holes for uprights  
with steel roof



Once the wood-type roof section is prepared, the position of the locating holes for the uprights must be accurately marked on the underside of the roof valances. Use the footplate etching for this. Overlay the roof panel loosely onto the footplate etching and mark up through the required holes. Ensure the relevant holes are used by referring to the diagram. Use a 0.7mm bit in a pin vice to drill the holes and ACC short lengths of brass wire into these as per the photo. These pins later ACC into the bores of the tubular uprights to secure the roof in place. Store the roof to one side for the time being.

Prior to fitting the etched footplate, ensure the bunker is fitted to the model. The footplate permanently attaches on top of the existing diecast footplate, butting against the front of the bunker. Use ACC or epoxy to fix the footplate in place. Once secured, the relevant holes for the vertical uprights can be drilled down through the diecast footplate. Use a 0.7mm drill for this. Similarly drill the holes for the handbrake and engineer's seat columns.

The tubular uprights install using lengths of 0.7mm brass wire passed up through the relevant holes - depending upon the particular roof variant selected - and into the bores of the uprights. Use ACC to secure these in place and ensure they are truly upright. Use your preferred roof choice - loosely installed for the time being - to help keep things square whilst the adhesive securing the uprights cures fully. Roof panels are best left loose while work on the cab interior fittings is carried out.

### **CAB INTERIOR & BOILER FITTINGS**

Assemble the reverser as shown using small rivets provided. File away excess rivet tails leaving 0.5mm protruding. The reverser tabs into the slot provided in the footplate, its linkage extending forwards behind the engine's cylinders ensuring it does not foul any moving valve gear parts.

Make up the engineers seat using the casting provided and a length of brass wire. A couple of small brass bushes install as shown to help provide a secure fixing.

Assemble the handbrake. Simply add the handwheel and ratchet castings to the top and bottom of a length of brass wire as shown.

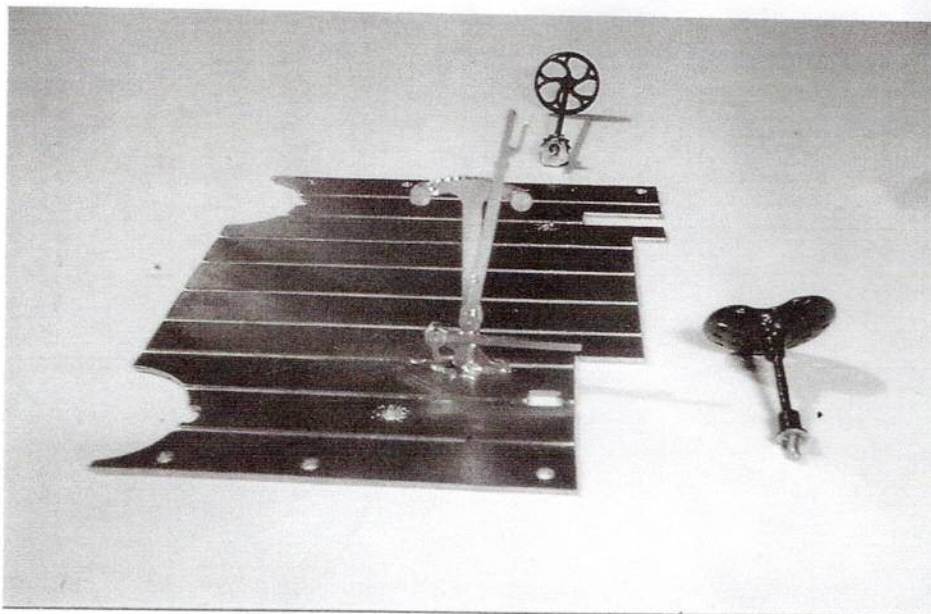
Pin the seat and handbrake assemblies to their respective holes in the footplate. Refit the moulded brake column at this time.

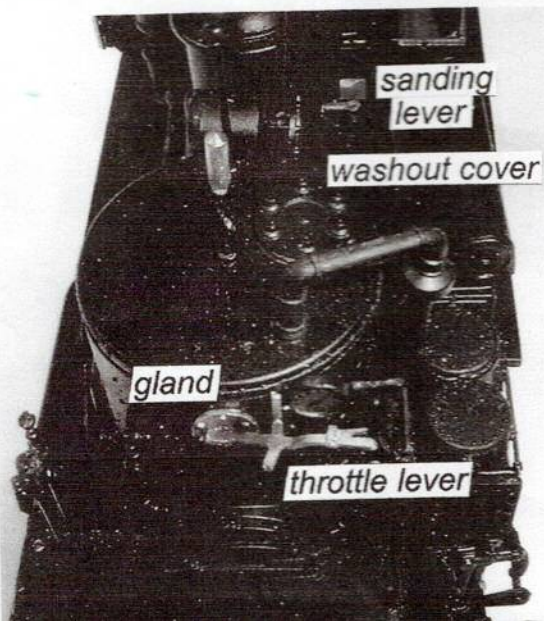
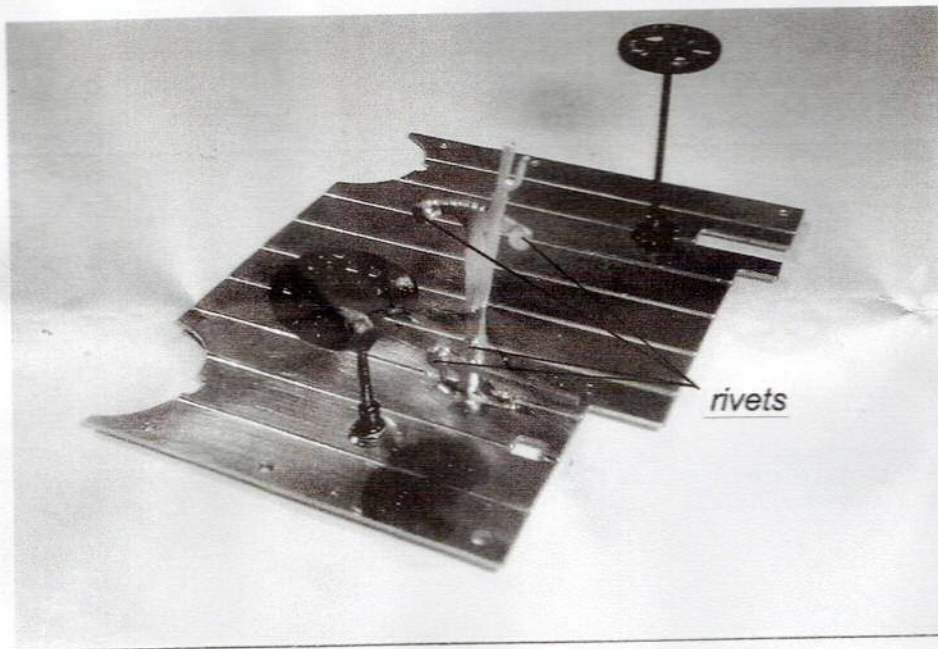
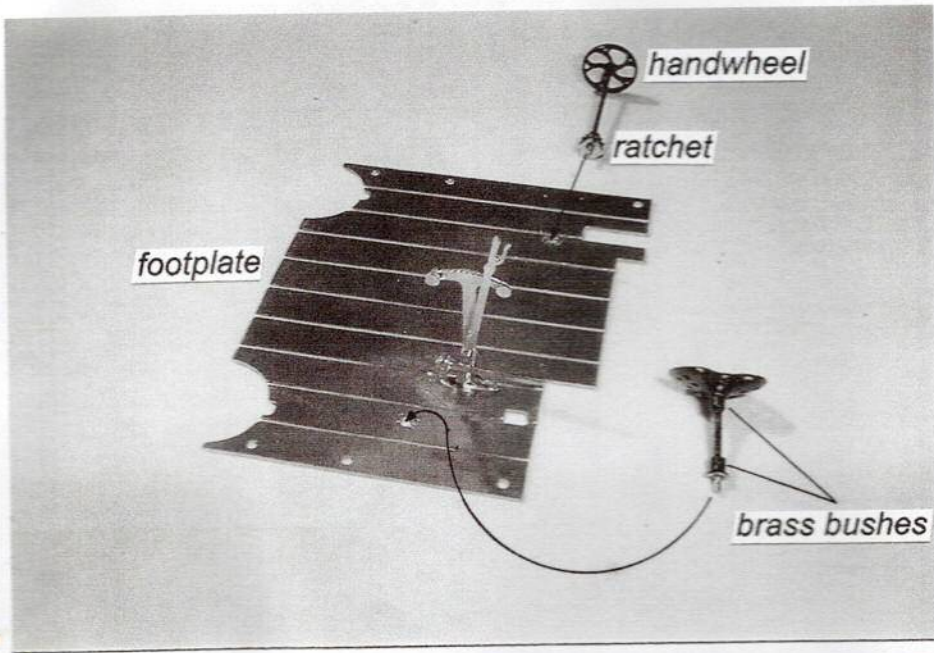
The etched throttle lever folds to shape and fits to the circular gland as shown. This assembly replaces the vaguely moulded protruberance currently masquerading as a throttle on the backhead.

A washout cover casting fixes to the top of the vertical firebox, just to the right of the whistle stem.

Now is the time to refit or re-connect the various items of plumbing disconnected when the original diecast cab was removed. Either salvage the original plumbing (mostly moulded) or fabricate replacements from suitable wire. A sanding rod is a sensible addition. This can be bent up from brass wire and attached to the small etched lever provided which can be fitted into a hole drilled in the right side of the sand dome.

Various smokebox number plates are provided if you wish to fit one of these.

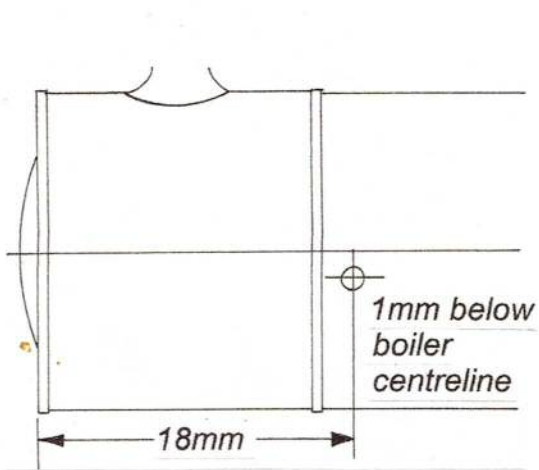




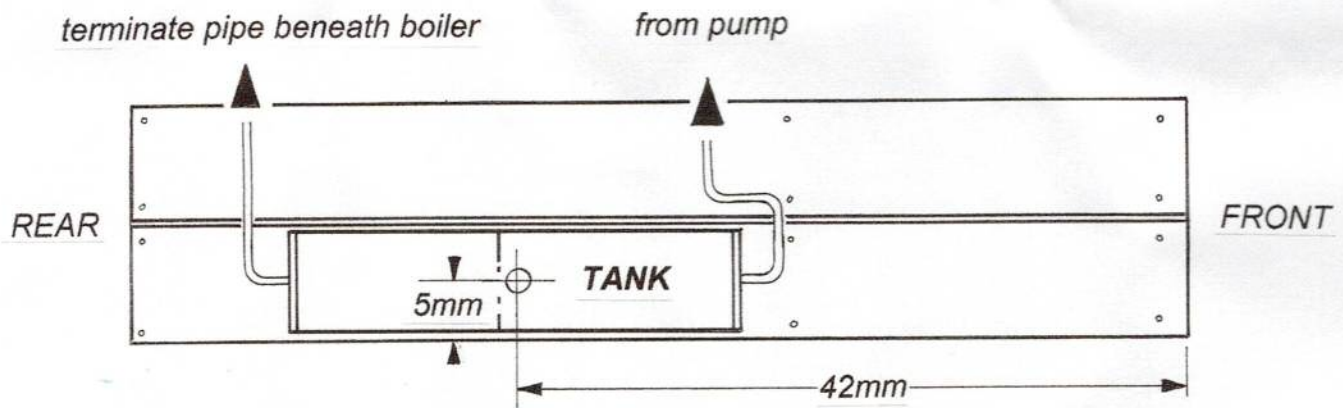
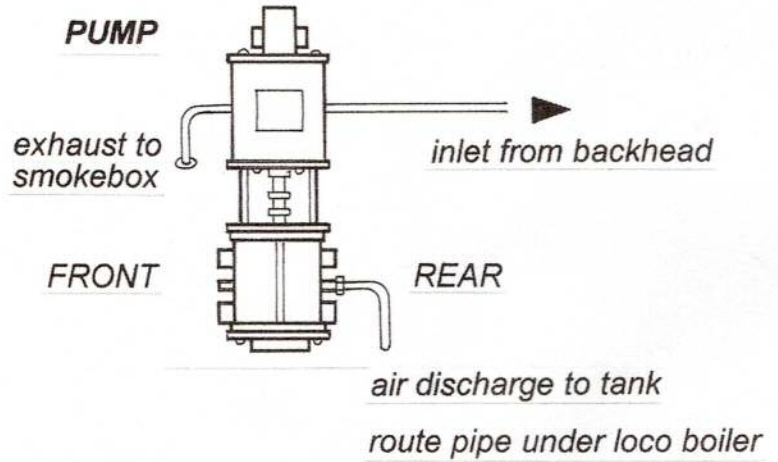
## AIR TANK & PUMP

The tank and pump require holes to be drilled for their location. Refer to the diagrams for the precise position of these fixing holes.

Plumbing for these fittings is fabricated from 0.7mm brass wire, bent up and installed as per the diagram.



**Drill hole for pump fixing spigot**



**Drill hole for tank mounting screw**

## **SMOKE STACK CHOICES**

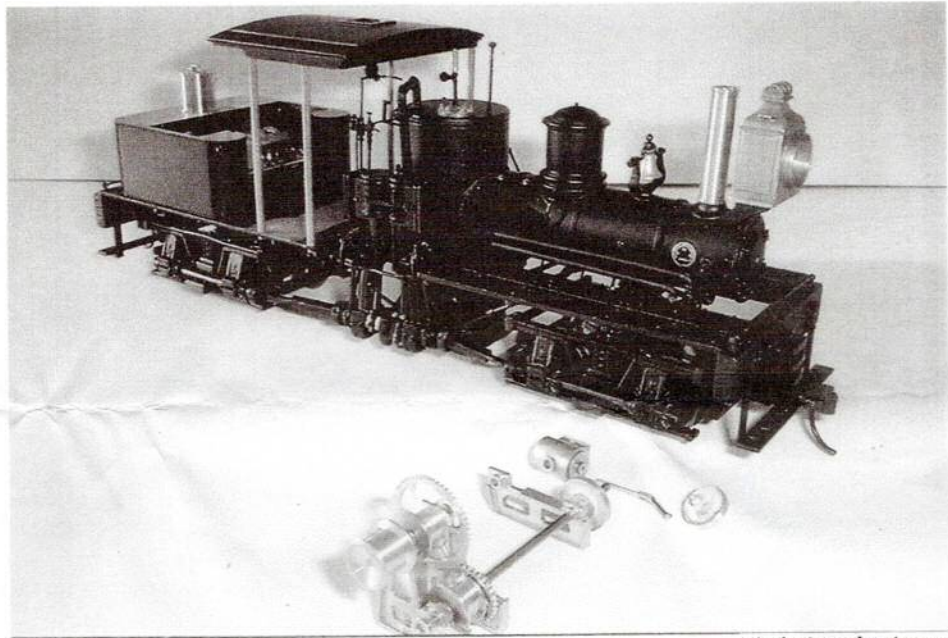
Our kit includes a further three stack alternatives to complement Bachmann's original offerings.

Provided are a beefy woodburner, dainty shotgun or elegantly capped stovepipe.  
Decisions, decisions....

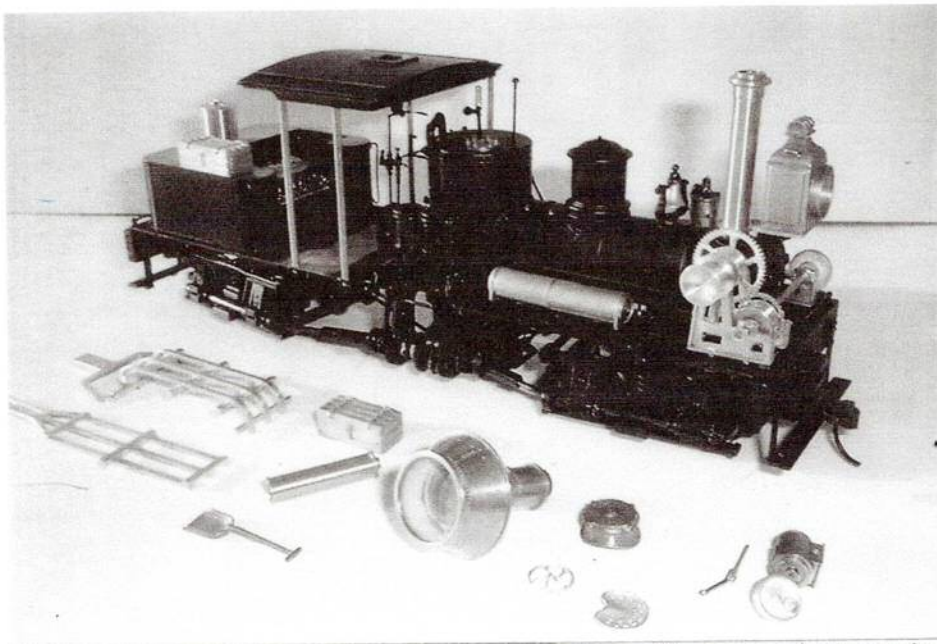
Removal of the Bachmann stacks is via a securing screw accessed via the stack bore. In the case of Bachmann's woodburning stack, it will be necessary to twist off the upper part of the stack to gain access to the fixing screw inside the lower portion.

Our shotgun and capped stacks merely glue into the original stack base which itself is simply glued to the smokebox. Whichever stack you choose, ensure it sits truly upright.

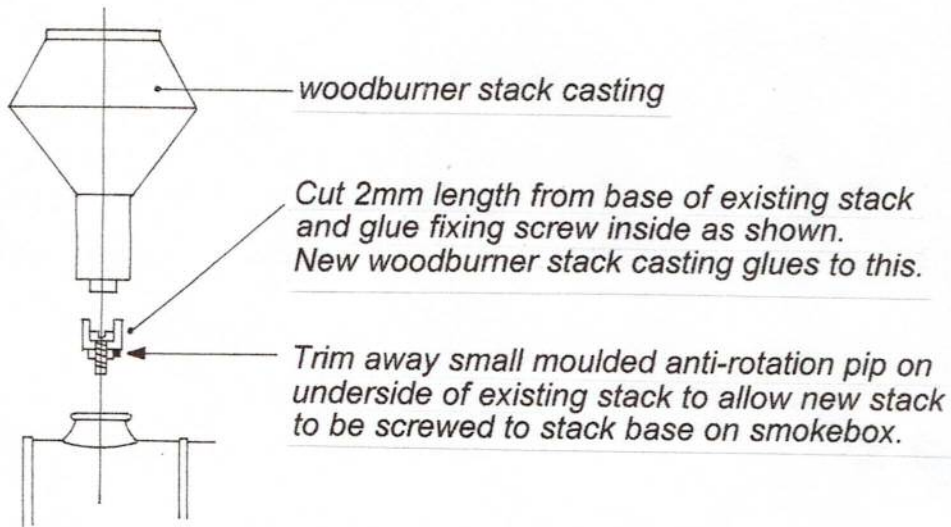
Our woodburning stack is fitted to a 2mm length of the original Bachmann stack - simply cut this from the base of the stack provided which in turn is screwed to the stack base. This new stack assembly glues to the smokebox. A spark arresting screen - not provided - is preferably fitted to the top perimeter of this stack.



*dainty shotgun*



*elegantly capped stovepipe*



## **HEADLIGHT**

*An alternative early-style box headlight is provided for those who prefer this to the original Bachmann offering.*

*To remove the original, prise off the smokebox door to access the insulated connecting wires attached to the headlight's LED. Disconnect these and withdraw the original headlight, leaving the bracket (ref OAB01).*

*A new etched base attaches to the original bracket and the box headlight sits on this. An etched rear plate for the box headlight is provided, as is a lens ring.*

*If you wish to re-use the Bachmann LED, ensure its un-insulated prongs do not short against any metal part of the loco during re-installation. Alternatively, a replacement 1.5v microbulb and necessary circuitry could be substituted.*

*etched base*



*etched lens ring*



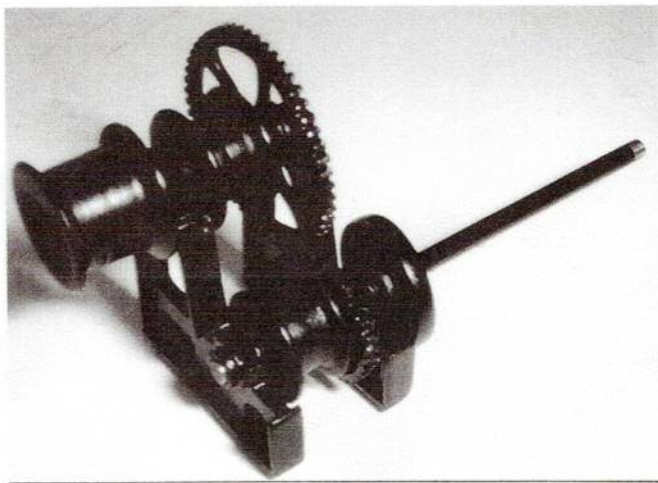
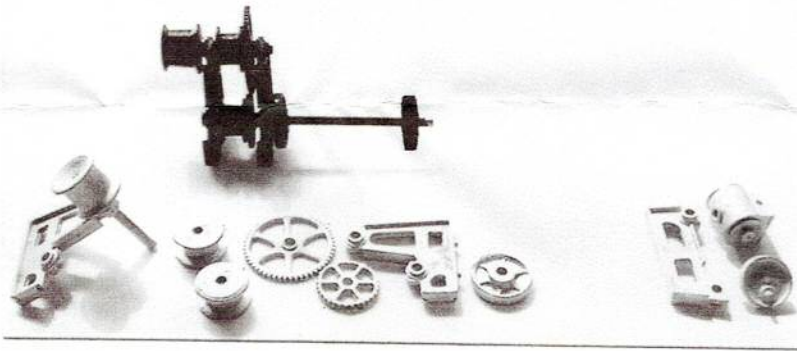
## GYPSY ENGINE

The gypsy engine assembles as per the illustrations. This is basically a two-part unit; the cylinder/flywheel assembly which fits to the left-side running plate and the actual winch assembly which installs onto the right-side running plate. The drive shaft linking the two parts passes ahead of the smokebox door and on the prototype set-up this must have been an easily withdrawn fixture allowing access for the door to open.

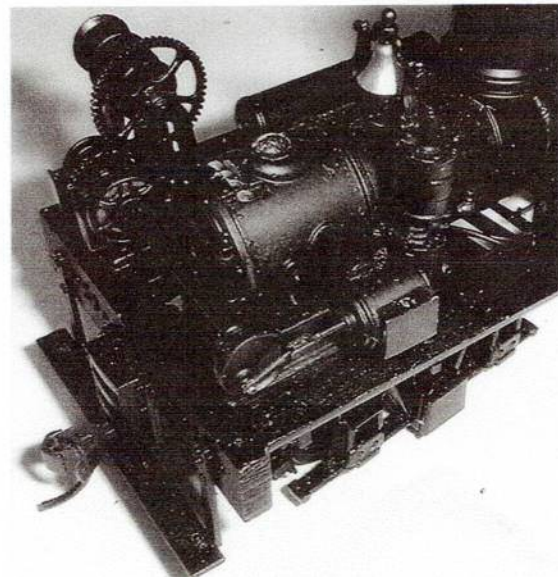
Begin by drilling the cylinder 0.7mm to accept the cast brass piston. Also drill the cast ring on the underside of the cylinder to accept the 1.5mm dia. exhaust pipe. This pipe is cut from 1.5mm dia. brass rod supplied and passes through the bracket casting and into the cylinder, positively locating it. The tail of the protruding rod represents the exhaust pipe and butts against the side of the smokebox once the bracket has been ACC'd to the left-side running plate in the position shown in the illustration.

Add the piston and connecting rod. The smaller end of the etched con rod fits between the clevis end of the piston and the big end of the con rod ACC's over the crankpin cast onto the flywheel.

The winch assembly makes up easily into the unit pictured. Use ACC to assemble the cast and etched parts. Note that it will be necessary to gently file away a few teeth from the large and small gear castings where they 'mesh' in order to achieve a correct fit. Ensure the etched baseplate of the winch assembly is installed correctly - the embossed bolt heads are set back from the leading edge. The completed winch unit attaches to the right-side running plate after carefully removing the leading boltheads from the diecast running plate so the etched baseplate sits correctly. Ensure the 1.5mm dia. driveshaft fits into the hole provided in the left-side cylinder bracket as per the photo.



cut winch driveshaft to 37mm length  
from 1.5mm dia. brass rod supplied



Steam plumbing for the gypsy engine is fabricated from 1mm dia. brass rod. This is nothing more than a feedpipe twist backhead and cylinder. An etched throttle lever is provided and this is sandwiched between two brass nuts fed onto the steam pipe. This throttle is installed as shown in the diagram. An etched valve chest cover fits onto the cylinder.

completed winch unit  
attaches to the  
etched baseplate  
over the  
right-side running plate

gypsy engine  
feedpipe  
plumbing

