



72-8022-250
4/00

***Lionel
Westside Lumber Shay
Steam Locomotive and Tender
Owner's Manual***



featuring **TRAINmaster** and *Railsounds*
C.O.M.M.A.N.D.

Congratulations!

You own one of the most sophisticated model trains ever built—the Lionel TrainMaster® Command-equipped Shay. From its hand-applied scale details to the

advanced technology found inside, your Shay is ready for duty on your model railroad layout. Experience the superiority of today's Lionel.

- Dependable Mabuchi® motor
- R2LC reverse unit for use with the Lionel TrainMaster® Command™ model railroad control system
- Smoke generator that produces clean, safe and realistic smoke
- Die-cast ElectroCouplers (front of locomotive and rear of tender)
- RailSounds™ digital sound system
- Brilliant Headlight and Marker Lights
- CrewTalk (in Command)
- TowerCom (in Command)
- Tire-Traction™
- Directional lighting
- Fire Box Glow

Table of contents

Transformer operations

| | |
|---|---|
| Running your Lionel Shay with a Lionel transformer | 3 |
| Locking your Shay into a single operational state | 4 |
| Using your Shay's ElectroCouplers | 4 |
| Your Shay's RailSounds system—the basics | 5 |
| Experiencing the range of your Shay's RailSounds system | 6 |
| Notes on RailSounds | 6 |
| Installing the Lionel Sound Activation Button | 7 |

TrainMaster Command operations

| | |
|--|----|
| Your Shay in the TrainMaster Command environment | 8 |
| CAB-1 commands for your Shay | 9 |
| RailSounds in the Command environment | 10 |
| CAB-1 numeric keypad commands for your Shay | 10 |
| Tuning your Shay's performance | 11 |
| Maintaining your Shay's handrail antenna | 11 |
| Assigning your Shay a new ID# | 12 |
| Reprogramming the R2LC circuit board to restore features | 12 |

Maintaining and servicing your Shay

| | |
|---|----|
| Lubricating your Shay | 13 |
| Replacing your Shay's lamps | 14 |
| Adding fluid to your Shay's smoke generator | 15 |
| Lionel Service | 16 |

Transformer operations

Running your Lionel Shay with a Lionel transformer

1

Place your Shay on Lionel or Lionel-compatible 0-54 or larger track.

- **Plug the tether from the locomotive into the socket in the front of the tender.** The plug is “keyed” to fit only one way.
- **With track power OFF,** connect the drive coupling between the engine and tender and then the drawbar.

NOTE: Your Shay is designed to operate on minimum 0-54 diameter track.

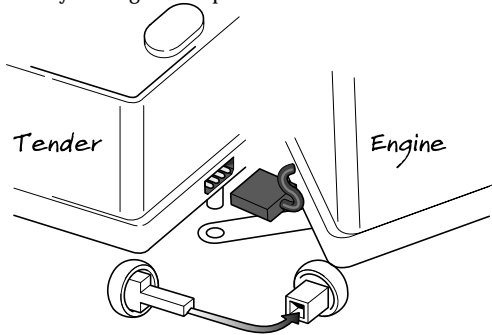

2

Power up your Shay with your transformer.

- **Your Shay is designed to operate on 8-18 volts alternating current.** Virtually all Lionel and Lionel-compatible alternating-current transformers are suitable; we recommend the TrainMaster Command model railroad control system.
- **Do not power your Shay with direct current (DC).** Damage to sensitive electronic components may occur.
- **When you first power up your track, the Shay will wait between three and eight seconds** as it “listens” for digital language from the TrainMaster Command Base (available separately). When it’s determined that it’s on a conventional (non-Command) railroad, the Shay’s headlight will illuminate and RailSounds will start up. At this point, the Shay is in neutral. (This occurs when placing the locomotive on your railroad for the first time. Thereafter, it starts in forward after every three-second power interrupt.)

Note!

3

Move ‘em out!

- **Get your Shay moving.** Press the DIR button on your CAB-1 remote or Lionel transformer. This sequences the R2LC to the next operating state.
- **Adjust track voltage** until your Shay moves at your desired speed.

Transformer operations

Locking your Shay into a single operational state

To select a single operational state for your Lionel Shay (example: forward only), you can deactivate the R2LC's sequencing function with the Program/Run switch, located on the left hand side, under the boiler casting.

Get your locomotive moving in the desired

direction, then slow it down without stopping. Set the Program/Run switch to PROG. The Shay is now "locked" into your chosen direction.

When you no longer want single-direction operation, just slide the Program/Run switch back to RUN.

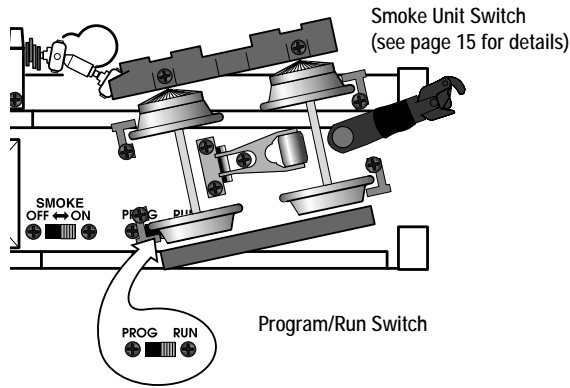

Using your Shay's ElectroCouplers in the non-Command environment

To use your Shay's ElectroCouplers in the non-Command environment, you must first couple a piece of rolling stock equipped with Lionel magnetic couplers directly to one of your Shay's ElectroCouplers. The magnet-

ic coupler on the rolling stock will then react to the magnetic field generated by a Lionel remote-control track section (available separately). Place your rolling stock's coupler "trigger disc" over the central coil of a remote-control track section and press "uncouple" on the controller. The magnetic field pulls the disc downward, and the coupler opens.

You use your Shay's front coupler in the same manner as above.

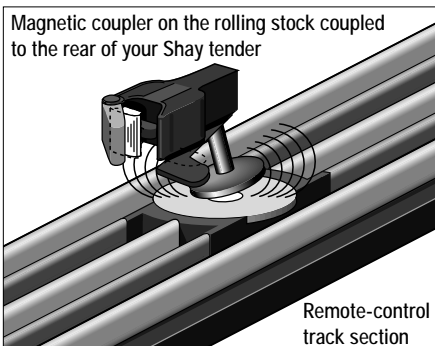

Note! Your ElectroCouplers will NOT open manually or by using a remote-control track section.

Your Shay RailSounds system—the basics

Lionel RailSounds is the most realistic model railroad sound system in the world. Your Shay features digital samples from real-life steam locomotives for the *ultimate* in realism.

Begin by installing a 9-volt *alkaline* battery in the tender. This ensures interruption-free operation of RailSounds. The battery clip is located in the tender. To remove the tender body, refer to the diagram on page 6 for location of mounting screws.

When you first apply track power, the Shay's RailSounds system produces sounds of

the locomotive at rest. As the Shay moves, chuffing begins, increasing with the locomotive's speed.

To silence the steam chuffing sound (whistle/bell are unaffected), slide the RailSounds switch, located on the underside of the tender (see page 6 for location), to the OFF position *before powering up the locomotive*. The whistle is activated by using the lever or button on your transformer or CAB-1. The volume control knob to raise or lower the level of sound is located on the underside of the tender (see page 6).

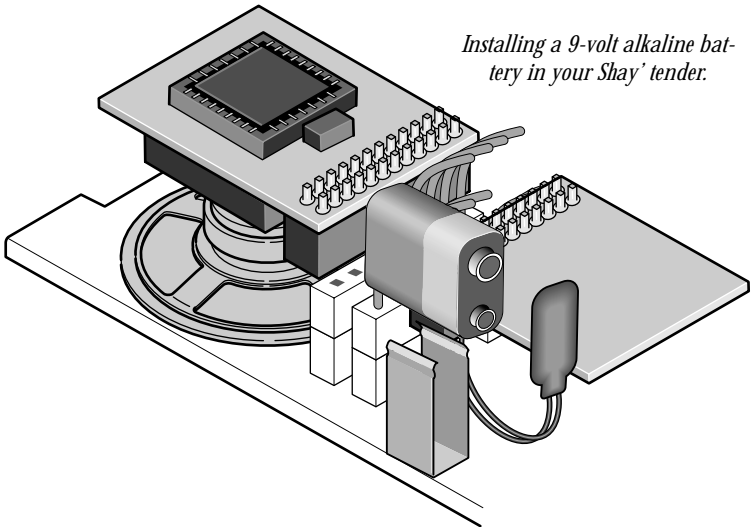

Installing a 9-volt alkaline battery in your Shay' tender.

Note! Please remove protective cover from battery clip

Note! Although RailSounds is powered by track voltage, *the battery is required* for uninterrupted operation and shutdown sequences. Use only alkaline batteries.

Note! Discontinue locomotive power *for 10 seconds* before changing the RailSounds ON/OFF switch position.

Note! If RailSounds “drops out” during track power interrupts (direction change), replace the battery.

Transformer operations

Experiencing the range of your Shay RailSounds system

With RailSounds, you experience the sounds of real railroading like never before. Simply put, it's the most sophisticated, authentic model railroad sound system in the world. And remember—coming from inside your Lionel Shay tender are the authentic sounds of the RailSounds digital sound system. No other electric train can offer you **authentic** sounds. *That's* the power of Lionel.

- **Variable chuff rate.** Your Shay speed determines the steam chuff rate.
- **MultiWhistle™.** Different whistles every time—a RailSounds exclusive.
- **Authentic bell.** Press BELL on your CAB-1 or transformer to begin the effect, again to discontinue. Even the final “hit” is muted like the real thing.
- **Reverse unit reset sound.** Power down your track, wait for 3-5 seconds, and listen for the air-release sound—that's the Shay telling you its R2LC Command reverse unit has just *reset to forward operation*.
- **Shutdown sequence.** No other model railroad sound system shuts down like RailSounds. Turn off track power, and after the air-release reset sound, you have two seconds to restart your Shay. If you're done with operations, RailSounds will commence with an authentic shutdown sequence about two seconds after the air-release reset occurs.

NOTE: Battery must be installed for shutdown sequence.

Notes on RailSounds

- Use the volume control dial, located on the underside of the tender, to adjust sound output.
- Listen for incidental engine sounds during RailSounds operation. They're automatic and, of course, authentic.
- The 9-volt alkaline battery you installed ensures *continuous* sounds, even during short track-power interrupts.
- Longer track-power interruptions (including locomotive derailments) cause Rail-Sounds to shut down after about 7 seconds.
- For even *more* authentic RailSounds effects, operate your Shay in the TrainMaster Command environment. See page 8-10 for details.

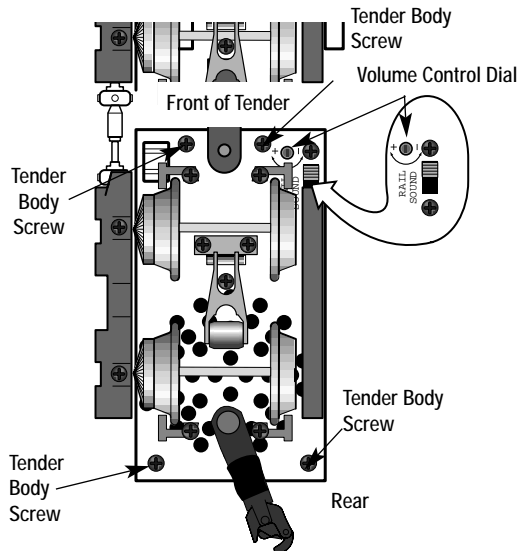

Installing the Lionel Sound Activation Button

To operate the bell and whistle sounds when operating your Shay with conventional transformers, you'll need to install the

Lionel no. 610-5906-001 Sound Activation Button (available separately). Connect the button(s) as shown below.

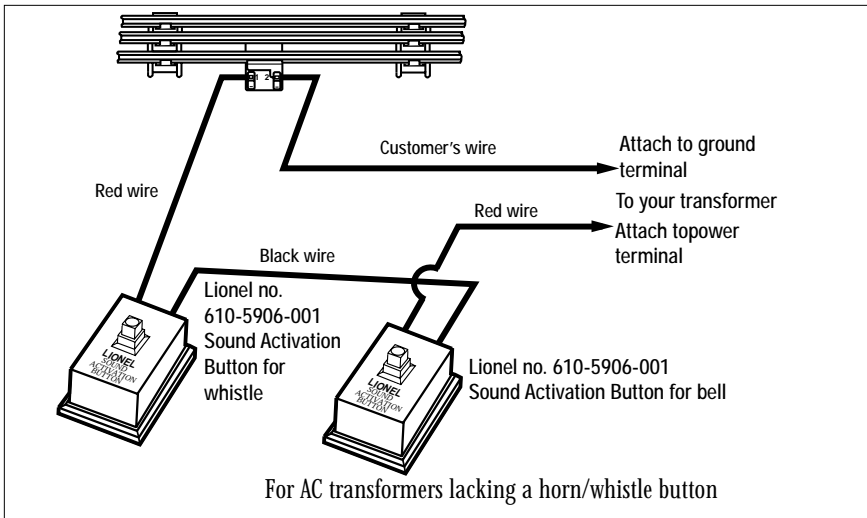
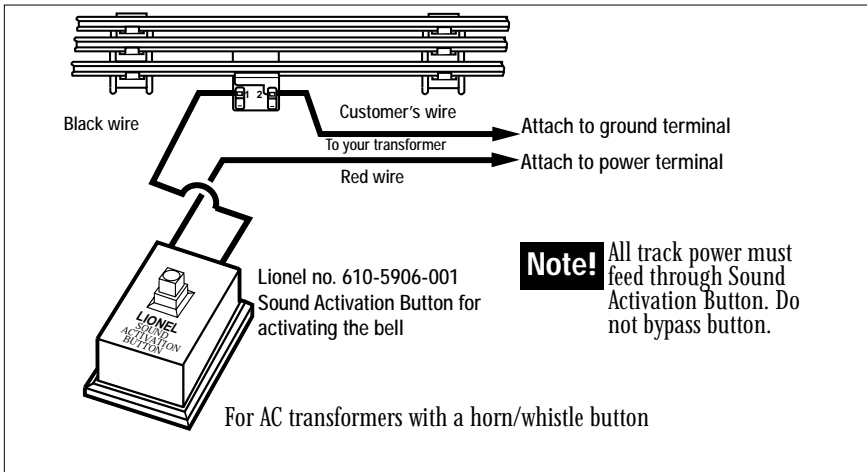

Note!

The no. 610-5906-001 button works with any Lionel AC transformer except no. 6-4690 Type MW. Transformers made by other manufacturers may not be compatible with RailSounds.

TrainMaster Command operations

Your Shay in the TrainMaster Command environment

Lionel TrainMaster Command is the fun and sophisticated model railroad control system from Lionel. Your Shay features the R2LC reverse unit, which acts as both a conventional reverse unit as well as the key to unlocking many extra features when you operate in Command mode.

TrainMaster Command gives you the power to operate multiple Command-

equipped locomotives *on the same track, at the same time*. It's the most fun you can have with electric trains, and it's incredibly easy too! Just follow the directions below and you'll be on your way.

To operate in Command mode, you need a Command Base and a CAB-1 remote. Find them both at your authorized Lionel retailer.

1

Place your Shay on Lionel or Lionel-compatible 0-54 or larger track.

- **Make sure track power is OFF before placing it on track.**
- **Make sure your Lionel Command Base is ON** and its communications wire is connected to the COMMON post on your Lionel transformer *or* the U terminal on any of your installed PowerMasters.
- Once positioned on the track, **increase track voltage to FULL** (on PowerMaster, slide the CMD/CONV switch to CMD).

2

Address your Shay with CAB-1.

- **Press ENG and 1** on the numeric keypad of your CAB-1 remote. This command is sent by CAB-1 to the Command Base, which then translates your commands into digital code. That code is sent around your railroad's outside rails in the form of a digital "halo." All Command-equipped Lionels listen to this digital communication, but they *do not respond* until they hear their own ID number.
- The digital language of TrainMaster Command—and not track power—controls the actions of Command-equipped Lionels. Track power is simply like gasoline in the tank of your car—it gives you the power to go places, but it doesn't tell you where to go or how fast to get there.
- **All Command-equipped Lionels come factory-programmed with an ID# of "1."** To change your Shay's ID#, see page 12.

3

Move 'em out!

- **Throttle up or press any command button on CAB-1.** Your Shay will respond to your *every* command. Read on. The fun is just beginning!

Running your Shay in the TrainMaster Command environment

Example Address Locomotive #1

PowerMasters set to CMD or traditional power supplies ON FULL



Press **ENG**



Press **1** (the ID#)

Throttle up/press any command button

Your Command-equipped Shay comes factory-programmed with an ID# of “1.” To get your Shay into action, set PowerMasters to CMD or set all power supplies on full. Press ENG and “1” on CAB-1. Turn the throttle or press any command button; RailSounds starts up. Your Shay is ready for Command operations.

CAB-1 commands for your Shay

Shay RailSounds effects in bold italic



Locomotive front coupler releases.

Coupler release sounds.



Tender rear coupler releases.

Coupler release sounds.



Press AUX2 to turn your Shay’s headlight on and off.



Turn the THROTTLE to the right to accelerate, left to decelerate.

Speed-dependent variable steam chuffing. DynaChuff dynamic chuffing effect.



Press HALT to shut down all PowerMaster electrical output on your railroad.

Stops all Command-equipped Lionels in operation.



Press WSTL/HRN to activate the Shay’s whistle, release to discontinue. **Multi Whistle steam whistle sound.**



Press BELL once to activate the bell, again to discontinue.

Traditional bell sound.



Press DIR—the locomotive decelerates to a complete stop; turn the throttle up, and the locomotive moves in the opposite direction. There is no neutral. **Steam air-release sound.**



Press and hold BOOST for extra power.

Release BOOST and return to the locomotive’s previous speed. **Labored chuff.**



Press and hold BRAKE to slow down or stop.

Release BRAKE and return to the previous speed. **Squealing brake sounds.**

TrainMaster Command operations

RailSounds in the Command environment

Your Shay RailSounds system gives you even *more* in the TrainMaster Command environment.

- **DynaChuff™**. Real steam locomotive chuffing depends on the locomotive's load. DynaChuff simulates both labored and relaxed chuffing sounds. Highball down the mainline and hear the labored chuffing of a locomotive battling inertia. Reduce your throttle setting, and chuffing relaxes to a

more sedate sound, as though the load placed on the Shay has decreased. Experience DynaChuff on steep grades, at yard crawls, and at speed. *Another* RailSounds exclusive.

- **Bonus sounds** like squealing brakes with the CAB-1 BRAKE command.
- **Incidental sounds** you control with CAB-1 numeric keypad commands, like steam let-off and steam release effects.

CAB-1 numeric keypad commands for your Shay

When you press AUX1 on CAB-1, you turn the numeric keypad into 10 command buttons. The keypad “stays open” and gives you access to extra command features until you press any top-row button (SW, ACC, RTE, TR, or

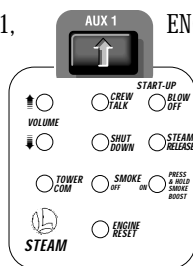

ENG). The CAB-1 keypad overlay included with your Shay is designed to help you learn the auxiliary features specific to this classic locomotive.

Shay RailSounds effects in bold italic.

0 Stops and resets the Shay to FORWARD. ***Whistle blows. Headlight flickers.***

1 Raises the volume of RailSounds. ***Sound volume increases.***

2 CrewTalk™ is the sound of unintelligible walkie-talkie communication.

3 Starts up RailSounds. ***Start-up sequence commences. Steam blowoff sound.***

4 Lowers the volume of RailSounds. ***Sound volume decreases.***

5 Activates the RailSounds steam shut-down sequence. Just like the real thing, *your Shay must be idle for shutdown to occur.* ***Steam shutdown commences.***

Remember, the whistle and bell will not sound until you *restart* RailSounds.

CrewTalk sounds

6 ***Steam release sound.***

7 TowerCom™ is an audible announcement that includes that engine's road number and/or name. *There is a four second delay in this function.*

8 Turns off the smoke generator. ***CrewTalk sounds***

9 Turns on the smoke generator. Press and hold 9 (10 seconds maximum) to initiate Smoke Boost™—it superheats the smoke generator and enhances smoke output when you start running your Shay. ***CrewTalk sounds***

Tuning your Shay performance

MOMENTUM

Simulate the labored performance of a locomotive pulling a heavy load with momentum. Press L, M, or H (located under CAB-1's removable panel) for light, medium or heavy momentum. The R2LC remembers the setting until you change it. For delayed response, use H. For quick response, choose L.

BOOSTING AND BRAKING

Use the BOOST and BRAKE command buttons for incremental control of speed *and* a superior method for handling grades, stops-and-starts, and more. Plus, using BRAKE in the Command environment gives you a bonus RailSounds effect—the ultra-realistic sound of squealing brakes.

STALL

Make your Shay feel more responsive by setting a “stall” voltage. Get your locomotive moving, then press SET; the Shay will stop. The headlight will flash, indicating it's in the SET mode. Turn the throttle clockwise to get the engine moving, then decrease speed until the locomotive just stops. Then press SET again; the R2LC remembers the stall setting

Note! These settings will be lost when you assign a new engine ID number.

until you change it. To clear stall, press SET twice, holding it for one second each time.

HIGH VOLTAGE SETTING

Press ENG, the locomotive ID#, then press SET; the headlight will flash. Get your locomotive moving to the maximum speed you want it to run, then press BOOST. Use this to keep your locomotive from accidentally being derailed at high speed.

Note! To clear setting, press ENG, the ID#, then immediately press BOOST.

SOUND QUALITY

To achieve your preferred RailSounds master volume level, use the volume control dial located on the bottom of the tender (see page 6). Turn the dial left or right to adjust the volume to your liking.

For quick remote-control of volume *below* the master setting—like muting—use the CAB-1 numeric keypad's volume control. Pressing AUX1 and 4 on the keypad lowers overall RailSounds output.

Maintaining your Shay's handrail antenna

Your Shay's handrails are more than just model grab irons—they're the R2LC's antenna for receiving Command Base digital communications. *Please handle the Shay carefully to avoid handrail damage.* To ensure optimum reception, both handrails are insulated from the die-cast shell. If your Shay experiences difficulty

receiving Base communications, check the handrail ends in the cab and pilot for the presence of insulating material. Ensure that each insulator is present and enjoys a proper fit. Finally, prevent the handrails from touching any part of the die-cast locomotive cab.

TrainMaster Command operations

Assigning your locomotive a new ID#

Example

Assign a new ID# to your Command-equipped locomotive

Command Base ON

Place the locomotive on track

PowerMasters set to CMD or traditional power supplies ON FULL

Set the locomotive PROGRAM/RUN Switch to PROGRAM (see page 4 for location)

Turn track power on (PowerMasters):



Press BOOST

Program the locomotive with a new ID#:



Press ENG



Press a number you choose (the ID#)



Press SET

Set PROGRAM/RUN Switch to RUN (see page 4 for location)

Your locomotive remembers its ID# forever; change it any time with these steps.

As your fleet of Command-equipped Lionels grows, give your Shay locomotive its own ID#. Choose from any between 1 and 99. Plug-in the Command Base and place the locomotive on track. Power up, then slide the locomotive's PROGRAM/RUN switch to PROGRAM. (See page 4 for location)

Using CAB-1, press ENG, the locomotive ID#, then press the SET button located under CAB-1's removable panel. See the locomotive's headlight flash; that's your signal that the programming has been accepted. Now slide the switch to RUN.

We recommend that you choose an easy-to-remember ID# for your locomotives. Some possibilities are part of the locomotive road number, your age, or any two-digit number that is not used by another locomotive. If you like, write the number on a small piece of tape and put this on the bottom of the frame to aid in remembering.

Reprogramming R2LC circuit boards to restore features

Due to the inevitable derailments, static, and the nature of electricity, it is possible that your R2LC could someday lose its setup program. The symptoms of this condi-

tion would be unresponsiveness in Command mode. This can be easily remedied by "reprogramming" your R2LC using the following steps.

STEP 1: Move switch on locomotive from RUN to PROGRAM.

STEP 2: Plug-in Command Base.

STEP 3: Place locomotive on track, then turn on power to track.

STEP 4: Press "ENG" then input locomotive's ID#. Press "SET"

STEP 5: Press "ENG," then the ID#, "AUX1", then press **the number 34**.

STEP 6: Turn off power to track, wait ten seconds.

STEP 7: Remove locomotive from track, move switch from PROGRAM to RUN.

STEP 8: Place locomotive back on track, turn power on to track.

STEP 9: Press "ENG" and ID#, then operate as normal.

Maintaining and servicing your Locomotive

Lubricating your Shay

Help your Lionel Shay lead a long and productive life on your railroad by maintaining it properly.

We recommend you purchase a Lionel Lubrication and Maintenance Kit (part no. 6-62927), available from your Lionel dealer.

Two basic rules to keep in mind: *never* over-lubricate (a small amount will do), and avoid getting grease or oil on the Shay's wheels, contact rollers, or your track.

You'll know your Shay requires lubrication when visual inspection reveals dryness on the parts indicated in the illustration. Remove accumulated dirt and dust before lubricating, and always lubricate any locomotive emerging from prolonged storage. Also,

lightly lubricate the Shay's side rods, drive rods, linkage, front and rear truck pivot points, and tender wheel bearings after each 25 hours of operation.

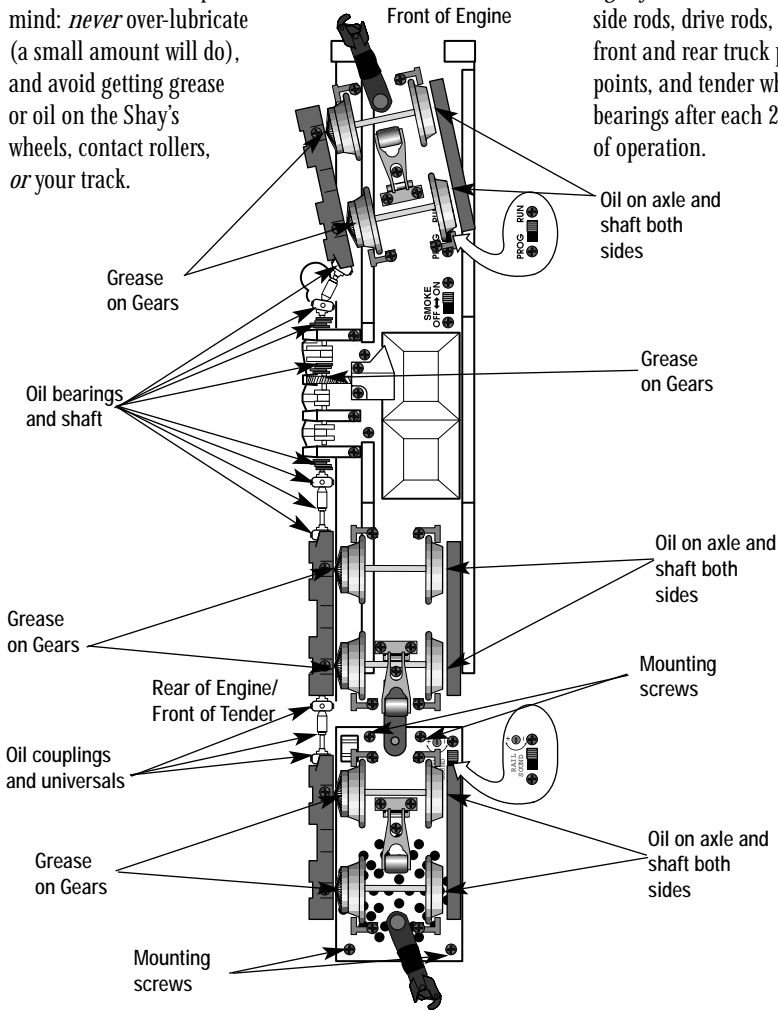

Maintaining and servicing your Shay

Replacing your Shay lamps (Locomotive)

Your Shay locomotive is illuminated by three lamps. One is located in the front pilot illuminating the headlight. The second is located behind the motor for the firebox glow, and the third illuminates the inside of the cab. During the course of normal operations, they may require replacement.

Note: Due to the complexity of the disassembly required to replace the lamps in your Shay, we recommend that you take your locomotive to your Authorized Lionel Service Center for any required lamp replacement.

Lamp Numbers:

| | |
|--------------------------|--------------|
| Headlight (1) | 620-8029-300 |
| Cab and firebox (1 each) | 610-8082-019 |

Replacing your Shay lamps (Tender)

Your Shay tender is illuminated by one lamp, located at the rear of the tender. Remove the tender body by unscrewing the four screws located on the underside of the tender (see page 6 for screw locations).

Carefully lift the tender body from the frame, taking care with the lamp wiring assembly which is still attached to the tender body. Remove the expired lamp and replace with Lionel part no. 620-8029-300. All lamps are available from your Authorized Lionel Service Center or direct from Lionel Service. See the Lionel Service section on page 16 for more information.

Reassemble in reverse order. While reassembling the tender, make sure all wires are inside the body before the screws are tightened.

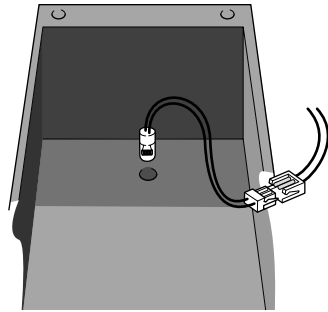

Tire-Traction™

Your locomotive is equipped with Tire-Traction. This means that four of the drive wheels are fitted with rubber traction tires to enhance tractive effort so your locomotive can pull many cars at once.

Lionel has provided extra traction tires to

replace the installed traction tires if they wear out.

Since replacing the traction tires requires disassembly of the drive trucks, you may wish to have a Lionel Authorized Service Station perform this service.

Maintaining and servicing your Shay

Adding fluid to your Shay smoke generator

Your Shay is equipped with a smoke generator that produces safe, clean, white smoke during operation.

The smoke generator requires the periodic addition of Lionel smoke fluid in order to function. Pierce the fluid tube's end with a pin, then add 10 to 15 drops of fluid directly into the Shay stack. Smoke production will commence momentarily, faster if you run your Shay at speed. When smoke production wanes, add more fluid (10 to 15 drops).

In Command Control, when the locomotive is first placed on the track and powered

up, the smoke generator will be in a default "OFF" position. Using any function key on your CAB-1 remote will turn the smoke generator on. Turning off the sound (AUX1-5) or resetting the engine (AUX1-0) will return the smoke unit to the initial "OFF" position.

Always keep a small amount of smoke fluid in the Shay smoke generator; the generator's element can become damaged if operated without fluid. Smoke production is greater at higher voltages and when the Shay is pulling a heavy load or long consist.

Note! Always keep smoke fluid in your Shay smoke generator. If not, turn it off when smoke is not desired using the switch shown on page 4 or the AUX1-8 command if you are running in Command mode. Using Smoke Boost with depleted fluid can damage the generator's element.

Limited Warranty/Lionel Service

This Lionel product, including all mechanical and electrical components, moving parts, motors and structural components, except for light bulbs, is warranted to the original consumer-purchaser, for one year against original defects in materials or workmanship when purchased through an authorized Lionel merchant.

This warranty does NOT cover normal wear and tear, light bulbs, defects appearing in the course of commercial use, or damage resulting from abuse or misuse of the product by the purchaser. Transfer of this product by the original consumer-purchaser to another person voids this warranty. Modification of this product voids this warranty.

Any warranted product which is defective in original materials or workmanship and is delivered by the original consumer-purchaser to Lionel L.L.C. or an Authorized Lionel L.L.C. Service Center, together with proof of original purchase, will at the option of Lionel L.L.C. be repaired or replaced, without charge for parts or labor. In the event the defective product cannot be repaired, and a replacement is not available, a refund of the original purchase price will be granted. Any products on which warranty service is sought must be sent freight or postage prepaid, as transportation and shipping charges are not covered by the warranty.

In no event shall Lionel L.L.C. be liable for incidental or consequential damages.

Some states do not allow the exclusion or limitation of incidental or consequential damages, so the above exclusion may not apply to you.

This limited warranty gives you specific legal rights, and you may have other rights which vary from state to state.

Instructions for Obtaining Service

If service for this Lionel L.L.C. product is required, bring the item, along with your dated sales receipt and completed warranty information

to the nearest Authorized Lionel Service Center. Your nearest Lionel Service Center can be found by calling 1-800-4-lionel, or by contacting our Website at www.lionel.com

If you prefer to send it back to Lionel L.L.C. for factory repair, you must first call 810-949-4100 or FAX 810-949-5429 or write to Customer Service, P.O. Box 748, New Baltimore, MI 48047-0748 stating what the item is, when it was purchased and what seems to be the problem. You will be sent a return authorization letter and label to assure your merchandise will be properly handled upon receipt.

Once you have received your return authorization and label, make sure that the item is packed to prevent damage during shipping and handling. We suggest that you use the product's original packaging. This shipment must be prepaid and we recommend that it be insured.

Please make sure you have followed all of the above instructions carefully before returning any merchandise for service.

Warranty Information

Please complete the information below and keep it, along with your dated sales receipt. You must present this and your dated sales receipt when requesting warranty service.

Name _____

Address _____

Place of Purchase _____

Date of Purchase _____

Product Number _____

Product Description _____

