

SONY

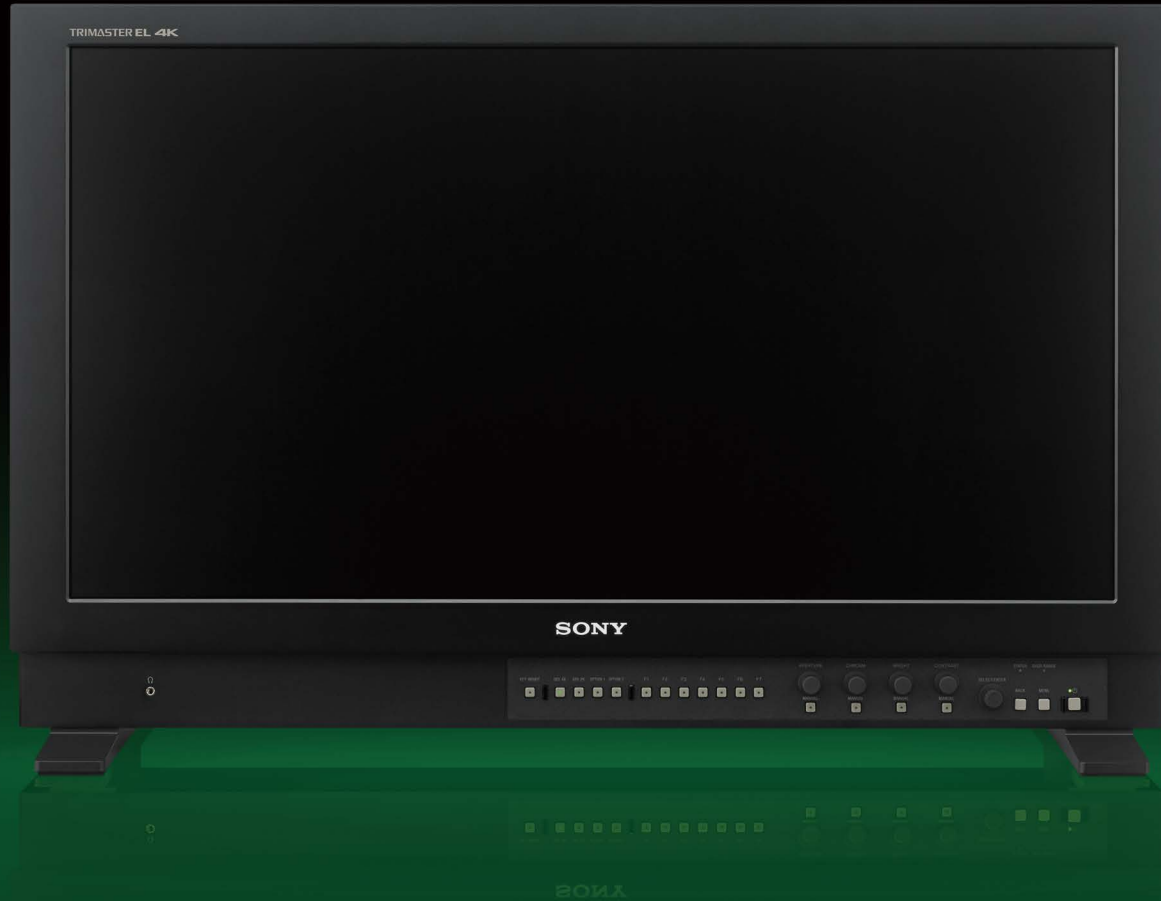

BVM-X300

4K OLED Master Monitor

TRIMASTER EL 4K

TRIMASTER EL 4K

4K OLED Master Monitor

- Indispensable for 4K Cinematography and Ultra-HD (UHD) Production

Sony proudly introduces the BVM-X300 30-inch*¹ 4K OLED master monitor – the flagship model in its professional monitor lineup. This new monitor offers the inherent performance of TRIMASTER EL™ OLED monitors, including unparalleled black performance, color reproduction, quick pixel response, and industry-leading wide viewing angles.

In addition, the BVM-X300 supports High Dynamic Range mode and a wide color gamut conforming to DCI-P3 and most of the ITU-R BT.2020 Recommendation.*² By unleashing these superb features and qualities, this master monitor makes an ideal tool for a wide range of applications such as color grading and QC (quality control) in the 4K production workflow.

*¹ 750.2 mm viewable area, measured diagonally.

*² The BVM-X300 does not cover the ITU-R BT.2020 color space in full.

4K 4096 x 2160 Pixel Resolution OLED Panel

The BVM-X300 incorporates a 30-inch true 4K panel at 4096 x 2160 pixel resolution. The aspect ratio is 1.89:1 (17:9) so images are mapped with no scaling processes.

High Dynamic Range Mode

In addition to the intrinsic high-contrast performance of the TRIMASTER EL OLED panel, this monitor provides High Dynamic Range mode. This offers never-before-seen image reproduction – the black is black, and peak brightness can be reproduced more realistically with colors that are typically saturated in a conventional standard dynamic range. This mode can brilliantly express sparkling town lights and stars in the night sky with no clipping.

Conventional standard dynamic range *



Highlight is clipped; less shadow detail

High Dynamic Range mode*



Render shadow detail to highlight

* Simulated images

Supports DCI P3 and ITU-R BT.2020 Wide Color Spaces

The BVM-X300 offers industry-leading wide color gamuts. It complies with the DCI-P3 color gamut and supports the ITU-R BT.2020 color space.* S-GAMUT3.cine and S-GAMUT3 color gamuts are also supported to achieve coherent cinematography production workflow with Sony's 4K cinematography cameras.

* The BVM-X300 does not cover the ITU-R BT.2020 color space in full.

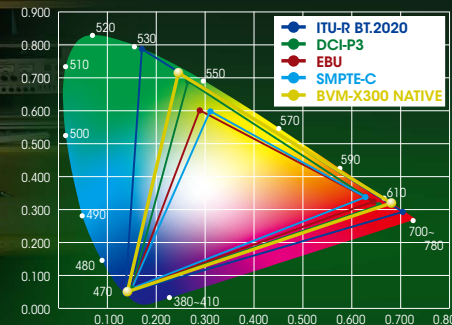

* Simulated image



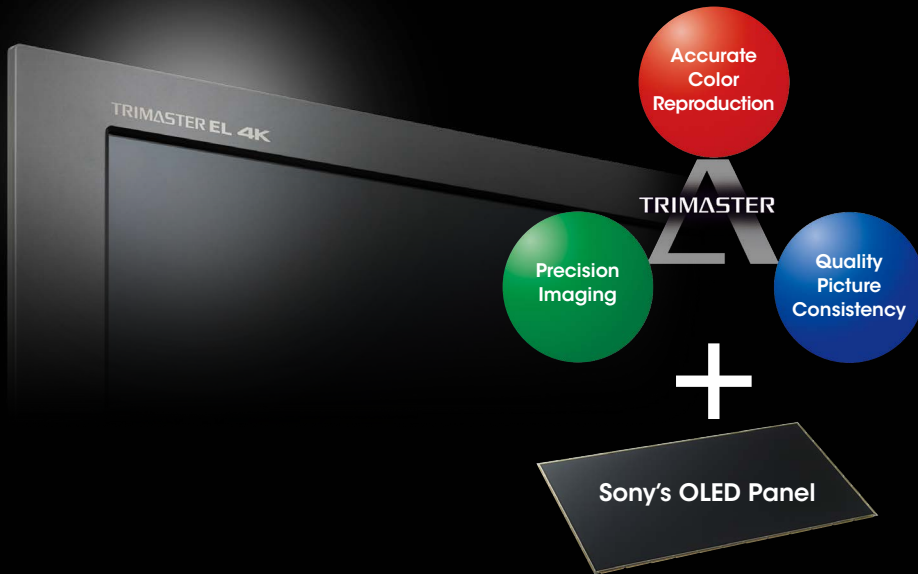

TRIMASTER EL

TRIMASTER™ Technology is a design architecture used to elicit the full performance capabilities of professional flat-panel displays. It comprises the core technologies that enable the highest level of color accuracy, precision imaging, and picture quality consistency.

EL (Electro-Luminescence) is an ideal self-emission display device with a wide dynamic range and high picture quality. By refining TRIMASTER technology with the new EL device, Sony effectively boosts the performance expectations of the professional industry.

Sony's BVM-X300 master monitor combines the latest innovative technologies with 4K, OLED, and HDR to offer content creators unparalleled superb image reproduction.

Accurate Black Reproduction

A key advantage of TRIMASTER EL is the fact that each pixel can be turned completely off. No other display technology is able to offer this. TRIMASTER EL is capable of reproducing accurate black with each individual pixel, enabling users to evaluate each picture image faithfully to the signal.

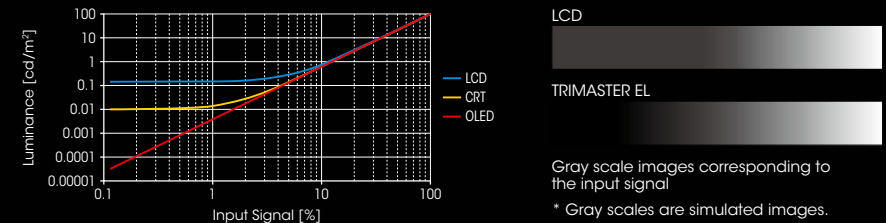

Accurate Color Reproduction

Sony's Super Top Emission technology not only offers a wide color gamut with its purity of the three primary colors, but also maintains this wide color gamut throughout the entire luminance range. TRIMASTER EL system is truly an ideal display device for picture evaluation. With Sony's OLED, users see the details in the blacks, and see the colors as well.

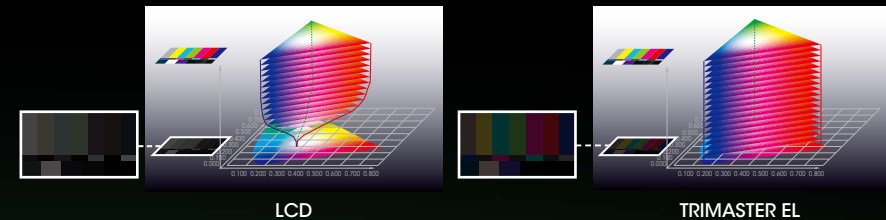

Quick Response with Virtually No Motion Blur

The TRIMASTER EL gray-to-gray switching speed (measured in microseconds, μ s) is much faster than that of the LCD (measured in milliseconds, ms). * This fast response benefits a variety of applications and uses.

* Sony's test results.



User-friendly Built-in Control Panel

The BVM-X300 incorporates a built-in control panel in front, which offers user-friendly convenient functions:

- Seven user-assignable function buttons
- Manual controls for aperture, chroma, brightness, and contrast
- Separate 4K and 2K settings, enabling users straightforward operation
- Dimmable button lights and on/off switchable indicator lights

The front panel design offers common operability with BVM-E and BVM-F Series master monitors*, and close operability with PVM-A and LMD-A Series monitors. This commonality between Sony's monitors in the same chain allows users simple operation and faster feature selection.

* BVM-E and BVM-F Series monitors use the optional BKM-16R remote control unit.

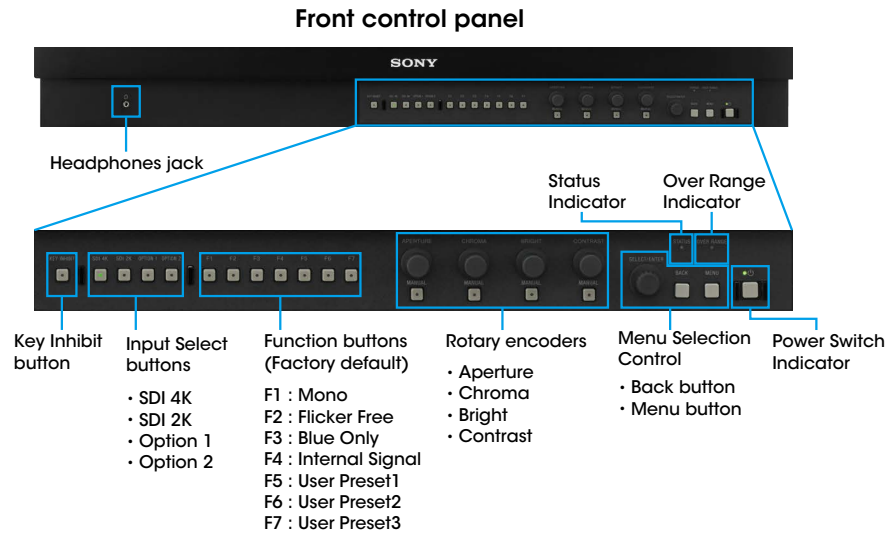

Versatile 4K/QFHD Input Capability

The BVM-X300 is equipped with standard 3G/HD-SDI input interfaces (x4) and supports 4K 2-sample interleave signals* and 4K square division signals.

This monitor accepts up to 3840 x 2160/24, 25, 30, 50, 60p and 4096 x 2160/24, 25, 30, 50, 60p signals.

* SMPTE ST 2036-3 standard.

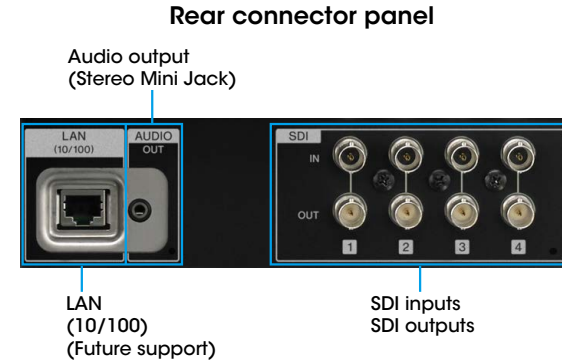

Interlace Mode

The BVM-X300 monitor offers an Interlace Display feature for 1080i input. This enables input to be presented as a true interlace display. As with the Native Scan function, Interlace Display mode offers faithful reproduction of the input signal, and the displayed interlace fields are free from the picture degradation that can occur as a result of typical I/P conversion processes.

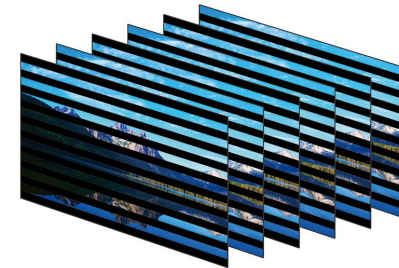

* Simulated image

Power-on Setting

This function allows users to select setting data when the monitor starts up; this includes last memory, user preset, and factory preset settings. Users can set the monitor accurately and quickly. This function is very useful for rental equipment.

User Presets

When multiple users share the same monitor, each user can memorize his/her settings and retrieve this data whenever required. This frees the user from time-consuming and repetitive setting tasks. Up to five User Presets can be memorized.

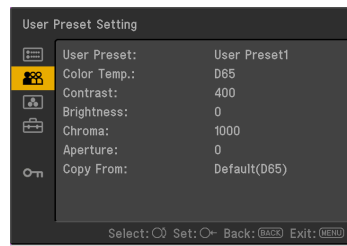

Password Lock for User Preset

When multiple users share the same monitor, each user can register his/her own password for color temperature and user preset data. This ensures the user correctly recalls their preset data, and keeps preset information safe from unauthorized use.

Key Inhibit

The KEY INHIBIT button located on the front panel protects each user's settings. When a user wants to change these values, the lock can be released.

Flicker-free Mode

The TRIMASTER EL OLED panel's superb quick response and scan-driving performance deliver stunning picture quality with virtually no motion blur. However, there is a possibility that flicker is just visible when a lower frequency signal is displayed (24p, 24PsF, and 50i).

To remove visible flicker, the BVM-X300 is equipped with Flicker-free mode.

Sony S-Log Gamma Support

The BVM-X300 supports conventional 2.2, 2.4, 2.6, and CRT gamma. In addition, HDR (High Dynamic Range) EOTF tables are provided for 2.4 (HDR), S-Log2 (HDR), and S-Log3 (HDR). The 2.4 (HDR) Gamma mode is for monitoring content using 2.4 gamma containing high dynamic imaging.

S-Log gamma is a technique used in Sony's digital cinematography cameras that allows the full latitude of the camera imager to be maintained throughout the production chain. Unlike conventional systems, in which highlight contrast is compressed, S-Log gamma logarithmically converts the video signal using characteristics similar to film negatives. This keeps the camera imager's dynamic range intact, even in extreme highlight areas. The BVM-X300 allows reproduction as an inverse function of the camera's S-Log gamma signals.

Two display modes are offered: S-Log2 and S-Log3.

Both of them enable easy workflow close to that of film, and deliver a 4K wide dynamic range. These log functions include the entire range captured by the camera. When the BVM-X300 is set to the S-Log mode, it will display this range without the need for any signal correction or user LUTs, and gives colorists complete freedom in creativity.

Other Features

- Aperture
- Internal Signal
- VESA Mounting (100 mm x 200 mm)

Signal Format

Signal System	Signal Format		
2K/HD (HD-SDI)			
1920 × 1080/60i*1, 50i, 30p*1, 30PsF*1, 25p, 25PsF, 24p*1, 24PsF*1	4 : 2 : 2 YCbCr	10 bit	
1280 × 720/60p*1, 50p			
2048 × 1080/30p*1, 30PsF*1, 25p, 25PsF, 24p*1, 24PsF*1			
4K/UHD (HD-SDI Quad link)			
3840 × 2160/30p*1, 30PsF*1, 25p, 25PsF, 24p*1, 24PsF*1	4 : 2 : 2 YCbCr	10 bit	Square Division
4096 × 2160/30p*1, 30PsF*1, 25p, 25PsF, 24p*1, 24PsF*1			
2K/HD (3G-SDI)			
1920 × 1080/60p*1, 50p	4 : 2 : 2 YCbCr	10 bit	Level A / Level B-DL
1920 × 1080/60i*1, 50i, 30PsF*1, 25PsF, 24p*1	4 : 4 : 4 RGB	10 bit / 12 bit	Level A / Level B-DL
1920 × 1080/30p*1, 25p, 24PsF*1	4 : 4 : 4 YCbCr		
1280 × 720/60p*1, 50p	4 : 4 : 4 RGB	10 bit	Level A
	4 : 4 : 4 YCbCr		
2048 × 1080/30p*1, 30PsF*1, 25p, 25PsF, 24p*1, 24PsF*1	4 : 4 : 4 RGB	10 bit / 12 bit	Level A / Level B-DL
	4 : 4 : 4 YCbCr		
2K/HD (3G-SDI Dual Link)			
1920 × 1080/60p*1, 50p	4 : 4 : 4 RGB	10 bit / 12 bit	Level A / Level B-DL
	4 : 4 : 4 YCbCr		
4K/UHD (HD-SDI Quad Link)			
3840 × 2160/30p*1, 25p, 24p*1	4 : 2 : 2 YCbCr	10 bit	Square division
3840 × 2160/30PsF*1, 25PsF, 24PsF*1			
4096 × 2160/30p*1, 25p, 24p*1	4 : 2 : 2 YCbCr	10 bit	Square division
4096 × 2160/30PsF*1, 25PsF, 24PsF*1			
4K/UHD (3G-SDI Quad Link)			
3840 × 2160/60p*1, 50p	4 : 2 : 2 YCbCr	10 bit	Level A / Level B-DL 2-sample interleave division / Square division
3840 × 2160/30p*1, 25p, 24p*1	4 : 4 : 4 RGB	10 bit / 12 bit	Level A / Level B-DL 2-sample interleave division / Square division
	4 : 4 : 4 YCbCr	10 bit / 12 bit	Level A / Level B-DL Square division
3840 × 2160/30PsF*1, 25PsF, 24PsF*1			
4096 × 2160/60p*1, 50p, 48p*1	4 : 2 : 2 YCbCr	10 bit	Level A / Level B-DL 2-sample interleave division / Square division
4096 × 2160/30p*1, 25p, 24p*1	4 : 4 : 4 RGB	10 bit / 12 bit	Level A / Level B-DL 2-sample interleave division / Square division
	4 : 4 : 4 YCbCr	10 bit / 12 bit	Level A / Level B-DL Square division
4096 × 2160/30PsF*1, 25PsF, 24PsF*1			

*1 Also compatible with 1/1.001.

Specifications

BVM-X300	
Picture Performance	
Panel	OLED panel
Picture size (diagonal)	750.2 mm (29 1/2 inches)
Effective Picture size (H x V)	663.6 x 349.9 mm (26 1/4 x 13 7/8 inches)
Resolution (H x V)	4096 x 2160 pixels
Aspect	17 : 9 (1.89 : 1)
Pixel efficiency	99.99%
Panel drive	RGB 10-bit
Panel frame rate	48 Hz / 50 Hz / 60 Hz (48 Hz and 60 Hz are also compatible with 1/1.001 frame rates)
Viewing angle (panel specification)	89°/89°/89°/89° (typical) (up/down/left/right contrast > 10:1)
Color temperature	D55, D61, D65, D93, DCI*1, and user 1-5 (5,000 K to 10,000 K adjustable)
Standard luminance	100 cd/m ² (100% white signal input)
Color space (color gamut)	ITU-R BT.2020*2, ITU-R BT.709, EBU, SMPTE-C, DCI-P3, BVM-X300 Native*3, S-GAMUT3, S-GAMUT3.cine
Transmission Matrix	ITU-R BT.2020 (Non-constant luminance is supported), ITU-R BT.709
EOTF	2.2, 2.4, 2.6, CRT, 2.4 (HDR), S-Log3 (HDR), S-Log2 (HDR)
Input	
SDI (3G/HD)	BNC (x4) Input impedance: 75 ohms unbalanced
Serial remote (LAN)	Ethernet (10BASE-T/100BASE-TX), RJ-45 (x1)
Output	
SDI (3G/HD)	BNC (x4) Input impedance: 75 ohms unbalanced
Audio monitor*4	Stereo mini jack (x1)
Headphones*4	Stereo mini jack (x1)
General	
Power requirement	AC 100 V to 240 V, 2.8 A to 1.2 A, 50/60 Hz
Power consumption	Approx. 280 W (max.) Approx. 150 W (average power consumption in the default status)
Operating temperature	0°C to 35°C (32°F to 95°F) Recommended: 20°C to 30°C (68°F to 86°F)
Operating humidity	30% to 85% (no condensation)
Storage / transport temperature	-20°C to +60°C (-4°F to +140°F)
Storage / transport humidity	0% to 90%
Operating / storage / transport pressure	700 hPa to 1060 hPa
Dimensions (W x H x D)	742.4 x 479.5 x 205 mm (29 1/4 x 19 x 8 1/8 inches)
Mass	16.0 kg (35 lb 4.4 oz)
Supplied accessories	AC power cord (1), AC plug holder (1), CD-ROM (1), Before Using This Unit (1)

*1 DCI: x=0.314 y=0.351

*2 The BVM-X300 does not support the ITU-R BT.2020 color space in full.

*3 The BVM-X300 individual chromaticity points. The widest color space setting of the signal is reproduced by the BVM-X300.

*4 Audio and Headphone outputs will be supported with future upgrade.

Dimensions

Front

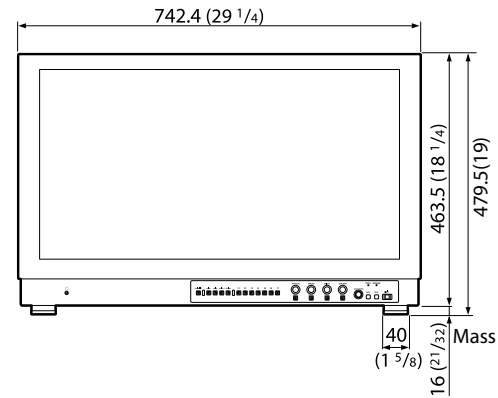

Side

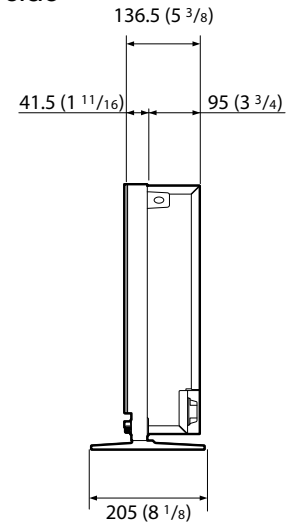

Rear

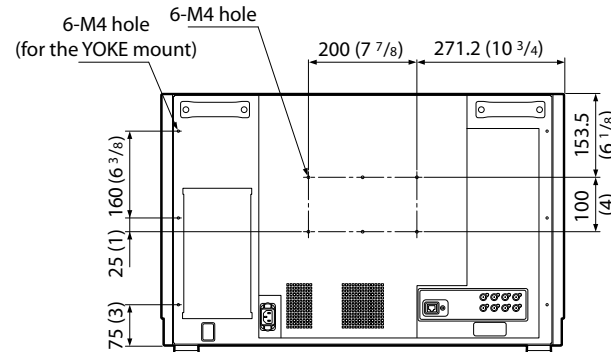

To install on a vehicle, fix the unit using screw holes for the YOKE mount.

Unit: mm (inches)

SONY

Distributed by

©2015 Sony Corporation. All rights reserved.
Reproduction in whole or in part without written permission is prohibited.
Features and specifications are subject to change without notice.
Screen images are simulated.

The values for mass and dimension are approximate.
"SONY" and "TRIMASTER EL" are trademarks of Sony Corporation.

The BVM-X300 is produced at Sony EMCS Corporation
Kosai Site, which has received ISO14001 Environmental
Management System certification.

