

Uninterruptible power supply

Selecting the right battery technology for long-lasting and safe DC UPS systems

Apostolos Baltos and Jochen Kessens



Whitepaper

TABLE OF CONTENTS

Introduction	03
Battery technologies for DC UPS systems	04
Decentralized UPS systems with extensive features	04
Application-specific dimensioning of a DC UPS	05
Influence of operating temperature	06
Energy and power density	06
Control and charging technology of DC UPS systems	07
PowerSharing avoids over-dimensioning of upstream power supply	07
Flexible use of various battery technologies	08
Supercaps as maintenance-free energy storage for short and medium bridging times	09
Double-layer capacitors - Highly efficient energy storage	09
Optimal cell voltage prolongs Supercap life	10
Lithium-ion technology allows longer bridging times	11
Structure and functionality of lithium-ion cells	13
Cycle life of lithium-ion batteries	13
Thermal runaway of lithium-ion cells	14
Lithium-iron-phosphate (LiFePO ₄) - the safe and durable lithium-ion technology	15
Battery Management System (BMS)	16
Cell Balancing function	17
Additional functions of BMS and energy storage	17
Battery Relax mode extends the life of lithium-ion batteries	17
System Present feature increases safety and storability of battery packs	18
Pure lead-tin batteries for extreme environmental conditions	18
Integrated DC UPS compact solutions	19
Modular DC UPS systems for maximum flexibility	20
Conclusion	20

Uninterruptible power supply Selecting the right battery technology for long-lasting and safe DC UPS systems

The complexity of processes and procedures in industrial and medical technology increasingly requires the fail-safe availability of process-relevant systems and components. This starts quite simply with the uninterruptible power supply (UPS) and the associated protection against power failures, flicker, fluctuations or voltage dips of 12V or 24V DC power supply.

Embedded industrial PCs, IIoT gateways, control systems, motor drives, sensors or safety technology. No matter which components are to be supplied, the possible failure of such elements causes a cascade of problems and risk factors in an increasingly networked world – keyword Industry 4.0 – that must be avoided. Decentralized and compact DC UPS systems, nearby the machine or even integrated into the systems, are being used for this task.



Figure 01

Modular DC UPS system UPSI

The requirements of an uninterruptible DC power supply are diverse and individual. Such an "insurance against power outages" should be implemented as cost-effective, durable, flexible and reliable as possible. In order to achieve these goals optimally, a detailed analysis of the application and detailed knowledge of the advantages and disadvantages of different battery technologies as well as a holistic view of the TCO (Total Cost of Ownership) are required. The aspects to be considered when selecting suitable battery technology are explained and illustrated in detail by means of the modular UPS system UPSI from Bicker Elektronik (Figure 01) including suitable energy storage units and battery packs.



Battery technologies for DC UPS systems

In essence, the following battery technologies are relevant for use in such DC UPS systems:

- Supercaps (Ultracapacitors)
- Lithium-ion batteries (especially lithium-iron-phosphate LiFePO₄)
- Pure lead-tin batteries (Cyclon cells)
- Classic lead-gel batteries

Figure 02 shows the different technologies and their properties in direct comparison.

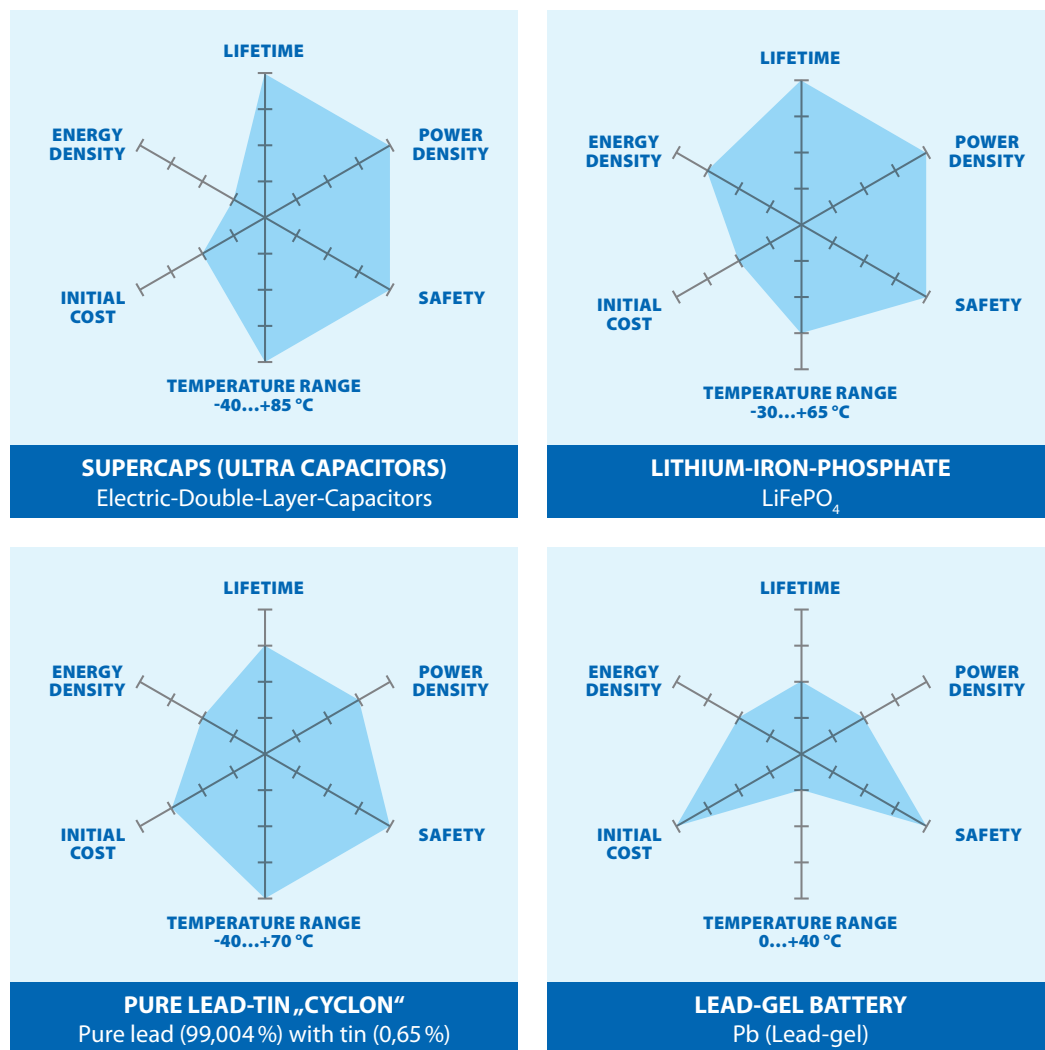

Figure 02

Property comparison based on manufacturer-specific examples. The parameters in the diagrams become better from the inside out.

Decentralized UPS systems with extensive features

Big, centralized UPS systems with a large number of battery cells connected in parallel and in series for supplying entire device groups are very maintenance-intensive and generally less energy-efficient, due to the AC/DC input transformers and DC/AC output converters. In contrast, the decentralized DC UPS systems shown here are compact and achieve a high efficiency of up to 97 percent.

Especially in the area of Industry 4.0 / IIoT with its distributed system architecture, but also for self-sufficient systems, this decentralized approach is unavoidable. Many smaller DC UPS units with correspondingly long-lasting and maintenance-free energy storages close

to the supplied load also increase the overall availability of the system and significantly reduce maintenance costs.

Intelligent DC UPS systems have real-time monitoring and can be remotely monitored and controlled via integrated communication interfaces. With the aid of UPS management software, operating data can be clearly visualized, parameters can be adapted and possible alarm and notification routines can be defined.

The individual integration and monitoring can also be implemented with the help of extensive instruction sets based on the communication protocol. In case of PC-based applications, it is also possible to shut down the system in a controlled manner and save important operating data in case of prolonged absence of the supply voltage.

In addition, the automatic disconnection of the battery pack prevents the energy storage from being discharged by the converter after shutdown and thus entering deep discharge, which would have extremely negative consequences in terms of service life for some battery chemistries.

The integrated reboot function automatically initiates the restart of the PC system after a recurring supply voltage, without requiring a complex on-site intervention by a service employee, e.g. for completely self-sufficient computer systems in inaccessible locations. In addition, a battery start function allows to manually activate the (separated) energy storage and thus initially start the system out of the battery, for example to carry out a diagnosis.

Application-specific dimensioning of a DC UPS

First of all it should be questioned which components of a system must actually be protected in the event of a power failure. For example, in an industrial PC system, the share of energy consumption for an integrated display can be around 40 percent. This means that if the display does not necessarily have to be operated in the event of a power failure, but only the computer unit, you can save up to 40 percent battery capacity and thus space and costs.

To calculate the required battery capacity, the defined power consumption in UPS operation is multiplied by the desired bridging time. Depending on the application, the required bridging time can be in the range of seconds, minutes or hours. For example, if a system with an average power consumption of 100 watts need to be bridged for 80 seconds in the event of a power failure, we need a battery capacity of 8,000 watt seconds (Ws) or joules (J). For longer bridging times, the calculation takes place in watt hours (Wh).

However, the battery capacity actually required is higher than the calculated purely nominal value, since efficiency losses and lower voltages due to temperature changes must be considered, as well as the fact that battery cells are ageing and have different useable capacities depending on discharge current and temperature. In addition, the battery capacity indicated on the cells can not be fully utilized, as compliance with overvoltage (OV) and undervoltage (UV) limits always requires some residual capacity. In general, power reserves should always be included.

Power supply manufacturers such as Bicker Elektronik use special programs and formulas for the correct calculation of capacity and to take account of all shown parameters and corresponding safety buffers.

Influence of operating temperature

The placement and the corresponding operating temperatures play a decisive role in the selection of a suitable battery technology: If DC UPS and energy storage can be separated from the hot machine environment, then classic and relatively cost-effective lithium-ion batteries with high energy density are a good choice.

If the energy storage device needs to be placed close to the machine or in a warmer environment and thus cope with higher operating temperatures, lithium-iron-phosphate batteries (LiFePO₄) or maintenance-free supercapacitors (EDLC), in short Supercaps, are much better suited.

At extremely low or high temperatures and high energy requirements, pure lead-tin cells are recommended as particularly robust and long-lasting energy storage.

In this context, the RGT (Reaction velocity–temperature) rule generally applies, which states that the reaction rate of a chemical reaction approx. doubles at a temperature increase by 10 K (Kelvin). Translated to electronic components and battery cells this means simplified, that the life of components halves by a temperature increase of 10 °C. Therefore, the analysis and optimization of temperature and thermal management of an application should be given special attention.

Energy and power density

Since the mentioned battery technologies sometimes differ significantly in terms of weight, cost, number of cycles, charge/discharge currents, safety as well as power and energy density (see Figure 03), these aspects have to be weighed exactly against each other. This process should be part of a professional design-in consultation with the power supply manufacturer at a very early stage of application development.

Figure 03
Comparison of energy
and power density

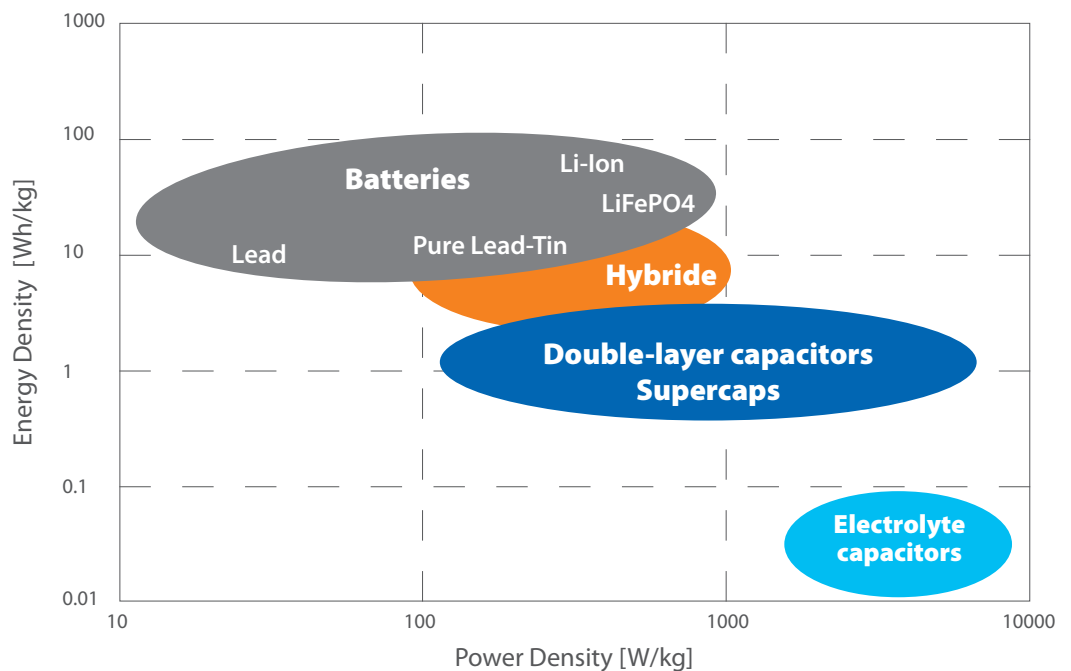

Control and charging technology of DC UPS systems

In addition to pure battery technology, the control and charging unit of the DC UPS system and its functional features are also very important. The UPSI control unit distributes the DC input voltage directly to the output during normal operation and simultaneously charges the energy storage.

At the same time, the DC UPS system measures and monitors all relevant parameters, currents and voltages. If the input voltage falls below the lower threshold due to large voltage fluctuations or a complete power failure, a MOSFET disconnects the input and the connected load is supplied from the energy storage unit. Switching from mains to backup UPS operation takes only a few microseconds.

For the charge and discharge (backup) process, a bidirectional converter (Buck Boost) was implemented as a central element in the UPSI system (see Figure 04). This makes it possible to save components and costs, while ensuring a very efficient and safe operation.

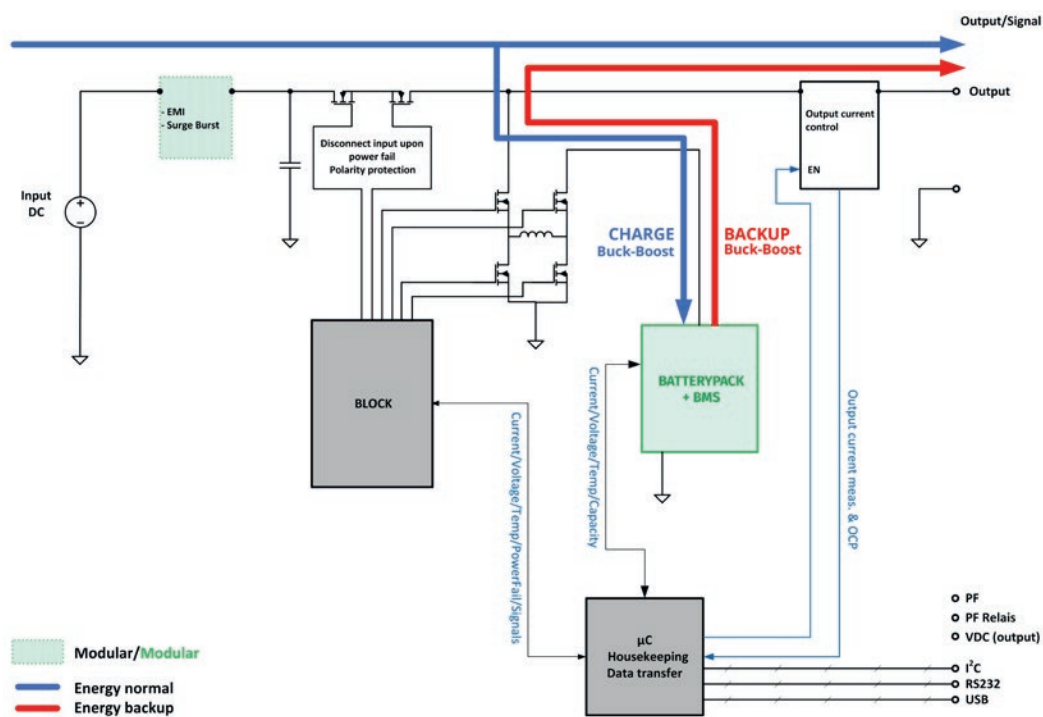

Figure 04
Block diagram DC-UPS
with bidirectional
buck-boost converter.

PowerSharing avoids over-dimensioning of upstream power supply

In normal operation, the DC UPS system divides the incoming power evenly between supplied load and battery charger, so that the input power can be kept constant. For example, the 24V DC UPS UPSI-2406 has a nominal power of approximately 140 watts in backup mode. The very powerful charging circuit can charge the energy storage with up to 4 amps. Assuming that the application would be designed for 120 watts and the charger would simultaneously charge the battery pack with 4 amps, this would result in a total power requirement of about 216 watts (120 watts for continuous operation + 4 A • 24 V for charging the energy storage device).

Taking the efficiency into consideration, an upstream power supply of the 300-watt class would be necessary to power a 120-watt system. Since this would be neither energy nor cost efficient, the DC UPS throttles the battery charge current depending on the connected load and thus limits the required power at the input. An oversizing of the upstream power supply can thus be avoided, which in turn saves money and space.

Flexible use of various battery technologies

In order to use the UPSI system with different battery chemistries, three charging methods with individual end-of-charge voltage adjustments are implemented: Constant Current, Constant Voltage and Constant Power. The temperature curves of the battery packs are monitored by the BMS (Battery Management System). Each energy storage device has a battery management IC that communicates with the UPS control electronics via I²C bus (Figure 05). A microcontroller (μC) detects the type and data of the battery and adjusts the charging and discharging parameters. Thus, a customer can also opt for a different battery technology at a later date. The hot-swap function allows changing the energy storage even during operation.

SUPERCAP ENERGY STORAGE BP-SUC

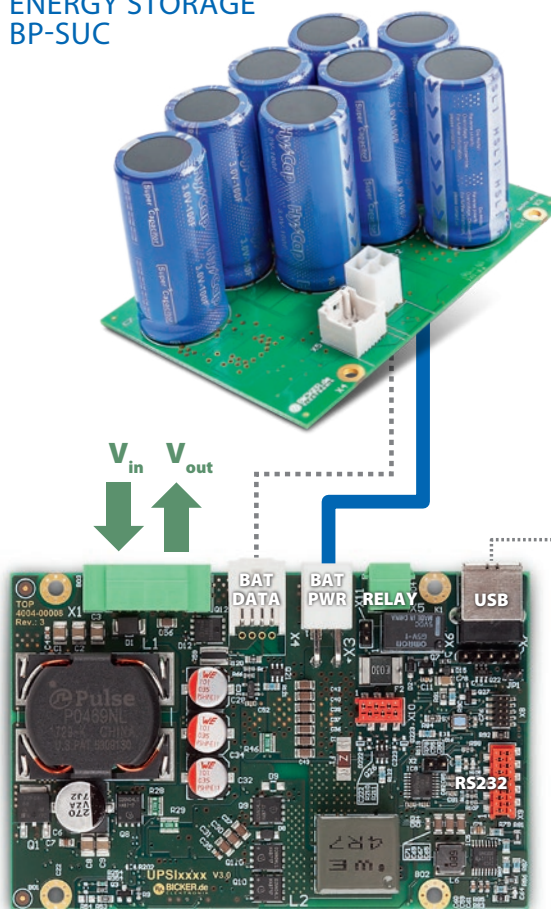

Figure 05

Energy and data connection of energy storage to DC-UPS.

DC-UPS UPS CONTROL UNIT AND CHARGER



SOFTWARE HID-BATTERY-PARAMETER

Supercaps as maintenance-free energy storage for short and medium bridging times

Energy storages with absolutely maintenance-free ultracapacitors, also known as supercapacitors or Supercaps, are available to protect against unstable supply networks or short-term power failures. These work on the principle of double-layer capacitors (EDLC - Electric Double-Layer Capacitor) and have a particularly high power density.

The achievable bridging times are up to the minute range, depending on the load to be supplied. In case of a long-term power failure a PC-based systems can be shut down safely, actuators can be moved to a defined home position or the current process step in automation can be completed by the stored power of Supercaps, just to name a few examples.

Unlike batteries, which store energy by the detour of a chemical reaction, supercaps are based on electrophysical principles and are charged and ready for use within a very short time, operate in a wide operating temperature range (-40 to +85°C) and convince with high current carrying capacity, power density and reliability.

Due to their high cycle stability (>500,000 charge and discharge cycles), energy storage devices with double-layer capacitors have a particularly long service life. For the supplied application, this means an increase in long-term availability while minimizing the maintenance effort. Even after reaching the EOL (End of Life), a double-layer capacitor is not defective, but has only a predefined reduction in capacity and a higher ESR (equivalent series resistance).

Double-layer capacitors - Highly efficient energy storage

In principle, capacitors consist of two electrode surfaces, which are located at a small distance to each other and separated by a non-conductive insulating layer called dielectric. If the electrodes are connected to a voltage source, in plain words they are charged in opposite polarity and generate an electric field due to the electrical potential between the two electrode surfaces. If both electrode surfaces are completely positive or negatively charged, the flow of current grind to a halt. The capacitor is charged and stores the electrical energy so that it can be used by connecting a load circuit.

The storage capacity or capacitance C of a capacitor depends essentially on the surface area of the electrodes and their distance from each other. Also, the nature of the dielectric (dielectric constant) is included in the formula for capacity calculation:

$$C [F] = \epsilon \cdot A / d$$

C Capacitance
 ϵ Dielectric constant
 A Surface area
 d Plate distance



In the development of double-layer capacitors or Supercaps, these parameters have been significantly optimized in some parameters, so that in comparison to ceramic, tantalum or electrolytic capacitors, very high capacities (up to several thousand farads) can be realized in a much smaller space: The electrodes of Supercaps consist of activated carbon, a pure carbon with a particularly large surface area of up to 1000 square meters per gram. On the other hand, the dielectric has been replaced by an electrically conductive electrolyte and an ion-permeable separator.

Figure 06 shows the basic structure of a double-layer capacitor. During the charging process, the negative anions migrate through the separator to the positive electrode, the positive cations move to the negative electrode. At the two boundary layers between carbon electrodes and electrolyte, the Helmholtz double layers are formed, which size only a few molecular layers. As a result of the extremely small spacing, there are electrical charge carrier layers with a particularly high power density, which behave like two capacitors of the same capacitance, which are connected in series via the electrolyte. The combination of large electrode area and minimal spacing at the boundary layers ultimately makes the double-layer capacitor a capacitive giant with compact dimensions.

Figure 06
Schematic structure of
a double-layer capacitor
(EDLC / Supercap).

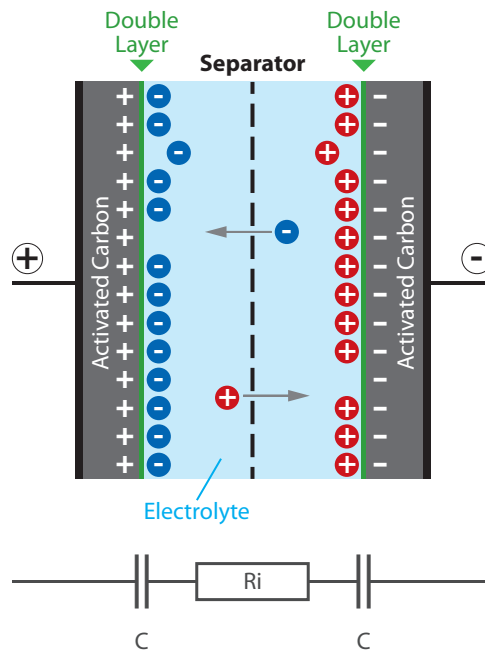

Optimal cell voltage prolongs Supercap life

Although the temperature resistance and lifetime of double-layer capacitors are particularly high compared to other energy storage devices, their capacitance (C) and internal resistance (ESR Equivalent Serial Resistor) change over time. The end of Supercap life is reached when the capacity drops to 70% of the original value or the internal resistance doubles.

The effective life depends crucially on the ambient temperature, the cell voltage and the charge/discharge currents. In contrast to standard lithium-ion batteries, minus temperatures do not pose a big problem for Supercaps, although the internal resistance increases at low temperatures due to the reduced mobility of ions in the electrolyte, but this is quickly compensated by the resulting heat development in the Supercap. High temperatures, however, negatively affect the Supercap lifetime.

Another important factor is the selected cell voltage. Figure 07 on the following page shows the direct relationship between temperature and lifetime at different cell voltages of a Supercap with a nominal cell voltage of 3.0 volts and a capacity of 100 F. For the Supercap energy storage modules BP-SUC (Open-Frame) and BP-SUC-D (DIN-Rail) Bicker Elektronik favoured a balanced solution with a reduced cell voltage of 2.6 volts (nominally 3.0 volts) per Supercap to ensure long-term operation in the defined operating temperature range of -30 °C to +70 °C.

As the amount of stored energy in the capacitor increases or decreases quadratically depending on the cell voltage ($W = 0,5 \cdot C \cdot U^2$), it was necessary to carefully weigh the cell voltage reduction during development. The usable amount of energy is reduced by the fact that Supercaps are discharged only to a minimum voltage U_{\min} of approximately 1.0 V, because 75% of the stored energy is already delivered when nominal capacitor voltage U_{\max} has dropped to half of its value. Thus, the effective amount of energy

$$W_{\text{effective}} = 0,5 \cdot C \cdot (U_{\max}^2 - U_{\min}^2)$$

is available for the application. A depth discharge below U_{\min} is therefore not appropriate, although a complete discharge would not harm the Supercap.

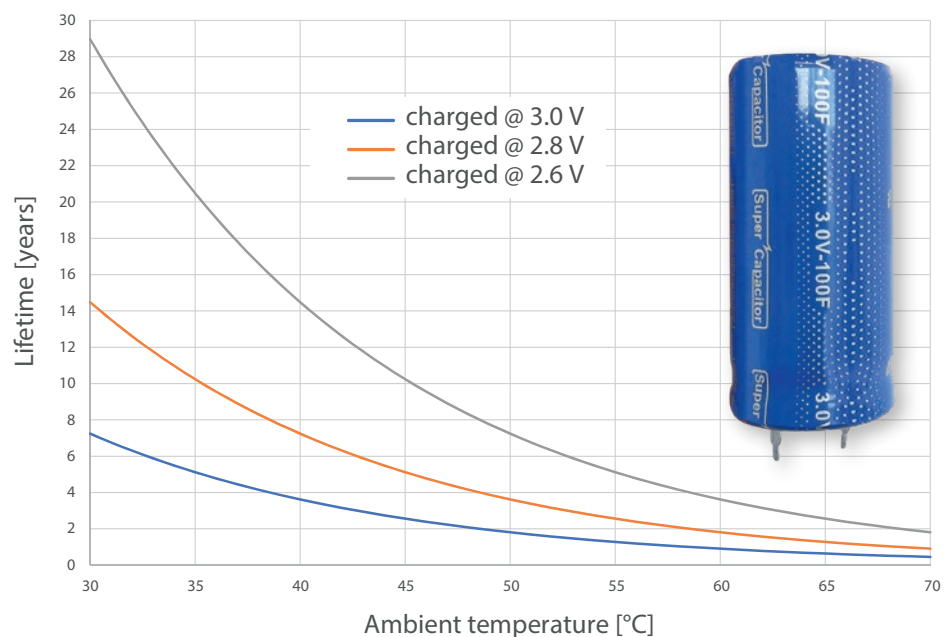

Figure 07
Connection between temperature and lifetime at various cell voltages.

Completely discharged Supercaps are particularly advantageous for storage and safe transport. However, Supercaps are generally tend to high self-discharge, which makes long-term storage of energy, like in conventional batteries, impossible. In addition, the serial connection of individual Supercaps in order to increase rated voltage of an energy storage unit urgently requires the use of a so-called cell balancing for charge equalization. Otherwise production-related differences in capacity and internal resistance of Supercaps would cause imbalance in state of charge, resulting in capacity losses and the possible overload of individual capacitors.

Lithium-ion technology allows longer bridging times

Although the fast and powerful Supercap energy storage offer impressive features and many possible applications for uninterruptible power supply, longer bridging times and the protection of applications with increased energy requirements does not make economic sense with double-layer capacitors, because of resulting large battery pack volumes and high costs.

Here, high-capacity lead or lithium-based energy storage devices are used, allow bridging times of up to several hours (depending on load). As a successor to conventional lead-sulfuric acid battery chemistry, modern lithium-ion batteries have become established not only in portable electrical devices and electromobility. These are more expensive

to purchase than conventional lead-gel batteries, but lithium-ion technology can achieve particularly high energy densities with space and weight savings of up to 75%. Lithium is the lightest metal of the periodic table and at the same time has ideal electrochemical properties for realizing high specific energy densities (Wh/kg). In addition the number of charging cycles, the possible DoD (Depth of Discharge) and the lifetime of Lithium-ion batteries are many times higher compared to conventional lead-gel batteries.

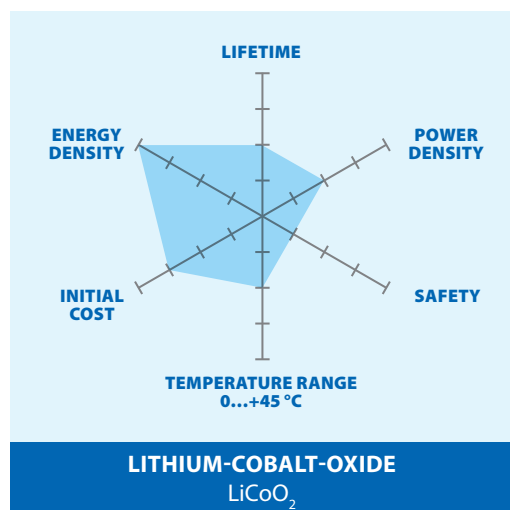
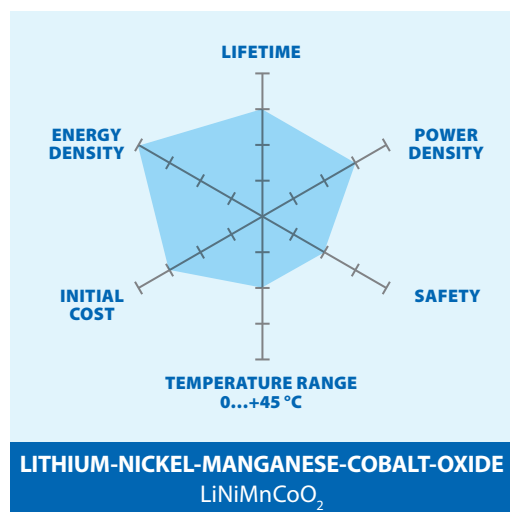
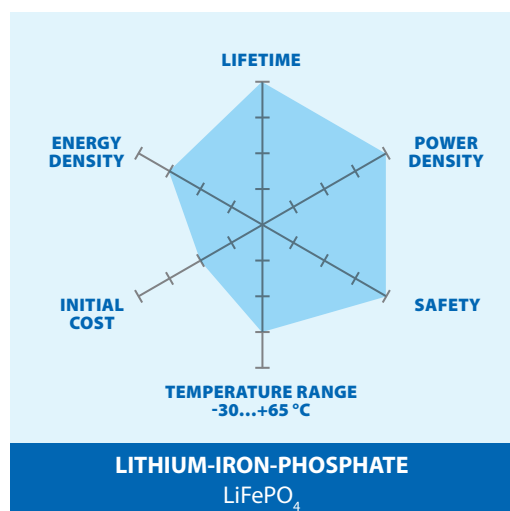

In addition to numerous other material combinations, **three cathode materials** for energy storage have become established for energy storage devices:

► **Iron-phosphate**

LiFePO₄

Lithium-iron-phosphate (LFP)

► **Lithium-metal-oxide compounds**

LiNiMnCoO₂

Lithium-nickel-manganese-cobalt-oxide (NMC)

LiCoO₂

Lithium-cobalt-oxide (LCO)

The different cathode materials of corresponding lithium-ion battery cells result not only in different nominal voltages, but also in a large number of other properties (Figure 08).

Figure 08

Property comparison based on manufacturer-specific examples. The parameters in the diagrams become better from the inside out.

Structure and functionality of lithium-ion cells

A lithium-ion cell (Figure 09) consists – in simple terms – of a cathode and an anode surrounded by an extremely pure and anhydrous electrolyte liquid, which is responsible for the optimal transport of lithium ions (a solid electrolyte is used in lithium polymer batteries).

The anode currently consists mostly of carbon (C) in form of graphite for embedding lithium ions from the active cathode material. The microporous separator, which is permeable only to the lithium ions, electrically separates the cathode (with aluminum electrode) from the anode (with copper electrode).

During charging process, the two electrodes are connected via a voltage source, which creates an external movement of electrons from the cathode to the anode. By removing electrons from the cathode material compound, the lithium atoms in the cathode begin to ionize. The positively charged lithium ions (Li^+) dissolve from the composite of the cathode material and now diffuse through the separator to the negative anode, recombine with the electrons to form neutral lithium atoms and become embedded into molecular graphite layer structure of the anode ($\text{LiC}_6 \leftrightarrow \text{C}_6 + \text{Li}^+ + \text{e}^-$).

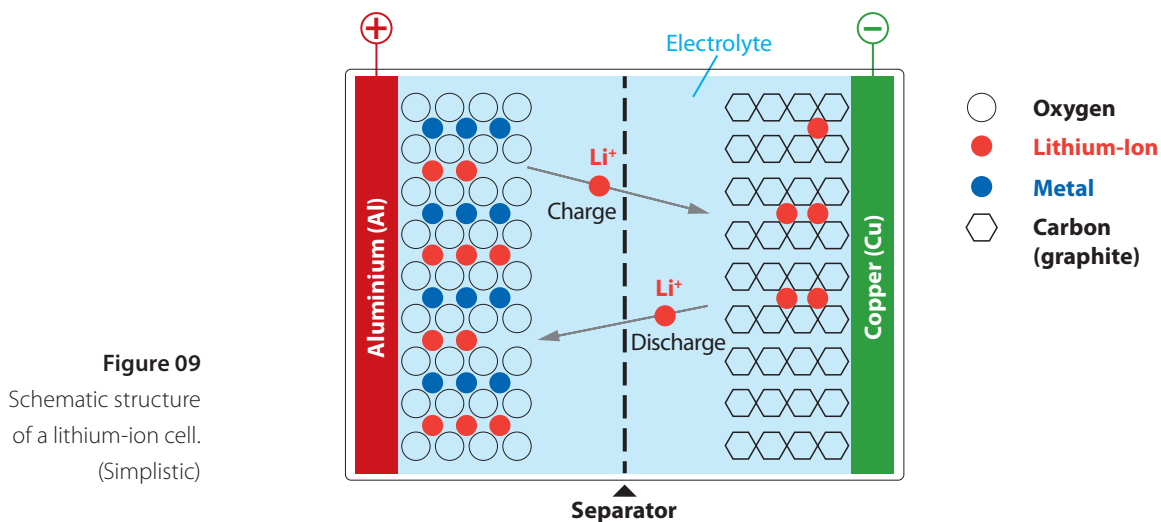

Figure 09
Schematic structure
of a lithium-ion cell.
(Simplistic)

During discharge process via a connected load, the process of electron and lithium-ion movement takes place in the opposite direction and the energy absorbed by the charging process is released via discharge current to the supplied load.

Cycle life of lithium-ion batteries

At each full cycle (charge/discharge), the lithium-ion cell is subject to chemical, thermal and mechanical stresses (expansion) that cause cell aging. In particular, charging with high currents (fast charging) and at low temperatures can lead to lithium plating at the anode. In this case, the lithium ions do not deposit, as intended, in the graphite layer structure of the anode, but are deposited metallically on the surface of the graphite anode and thus lead to significant performance losses or even short circuits within the cell.

High end-of-charge voltages or even overcharging also leads to a strong heat development and expansion of the lithium-ion cell. Charging and discharging profiles optimized for the energy storage with adapted end-of-charge voltages, optimized DoD values (Depth of Discharge) and the use of a battery management system (BMS) protect the materials of

the lithium-ion cell and ensure a long service life. Despite very low self-discharge, stored lithium-ion batteries should be recharged regularly in order to avoid a deep discharge and the associated destabilization of cell chemistry.

Thermal runaway of lithium-ion cells

When selecting a lithium-ion energy storage for DC UPS systems, it is advisable to take a closer look at the cathode material used, because lithium-ion technology repeatedly leads to negative headlines in terms of safety with images of burning electric cars or melting cell phones (Figure 10). The high achievable energy density due to the electrochemical benefits of lithium includes also an increased fire risk. Therefore, lithium-ion batteries are subject to special transport and airfreight regulations.

Especially in cells with chemically and thermally unstable cathode material such as lithium-cobalt-oxide (LCO) or lithium-nickel-manganese-cobalt-oxide (NMC) overcharging, an internal or external short circuit, mechanical damage, production-related impurities or strong external heat can cause an intracellular exothermic chemical reaction. The released heat energy increases the reaction rate of the cell chemistry and allows cell internal temperature to increase further.

This self-accelerating process can no longer be stopped if a specific temperature limit is exceeded. This temperature limit depends on the cell chemistry used. For example the critical temperature for lithium cobalt oxide (LCO) is at 150 °C. It comes to a thermal runaway, which can ultimately lead to fire or explosion of the cell. Since the bound oxygen is released from the cathode material in such a case, a fire is very difficult to extinguish.

Therefore, lithium-ion energy storage devices must be equipped with over-temperature (OTP), over-current (OCP), over-voltage (OVP) and short-circuit (SCP) protection circuits, as well as preventing direct exposure to heat and mechanical damage to the cells.



Figure 10

Serious consequences of a thermal runaway: mobile phone and battery are completely destroyed.
© Fotolia / weerapat1003

Lithium-iron-phosphate (LiFePO₄) - the safe and durable lithium-ion technology

With lithium-iron-phosphate (LiFePO₄), a cathode material with a much more stable chemical compound and increased safety is available. In case of an overload, the resulting heat energy is much lower and even in the "nail test" (internal short circuit of the cell by penetration of a metallic body) a thermal runaway of the cells is almost impossible, since lithium-iron-phosphate releases little to no oxygen in case of a failure and the specific thermal runaway temperature of 270°C is much higher than those of other cathode materials.

LiFePO₄ cells are generally much less sensitive to heat and even use at minus temperatures is possible. The temperature range of commercial LiFePO₄ cells is defined from -30 to +65°C. However, the operating temperature range for the LiFePO₄ battery packs BP-LFP / BP-LFP-D from Bicker Elektronik has been deliberately specified from -20 to +55°C: No practical charge of cells is possible at extreme minus temperatures and due to self-heating the cells within a battery pack already reach in normal operation at +55°C ambient temperature an internal cell temperature of +65°C (and would thus be overloaded at higher ambient temperatures). An important detail that should be considered when comparing different cell and battery packs in terms of temperature specifications.

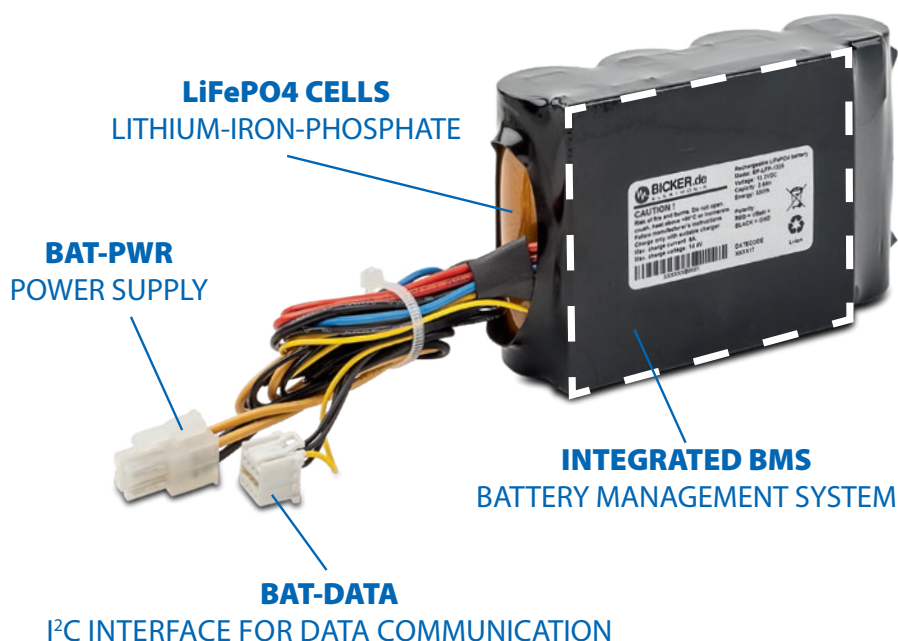

Figure 11
LiFePO₄ battery pack
BP-LFP from Bicker Elektronik
with integrated BMS.

Equipped with a high performance battery management system (BMS), LiFePO₄ energy storage devices are available both as shrunken battery packs BP-LFP (Figure 11) and in a rugged DIN Rail package BP-LFP-D at Bicker Elektronik.

Due to a slightly lower cell voltage of 3.2V, the energy density of LiFePO₄ cells is not quite as high as NMC/LCO cells. But this supposed disadvantage is already over-compensated after a short period of use by a ten times higher cycle stability (>3000 charging and discharging cycles at 80% of initial capacity). The cyclical aging of NMC/LCO cells is much faster and the cells show only 80% of the initial capacity after approx. 300 cycles. In this regard, the higher initial costs for lithium-iron-phosphate cells are put into perspective.

In addition, lithium-iron-phosphate energy storage devices have a higher power density compared to other lithium-ion batteries, which enables high charge and discharge currents and increased pulse capabilities.

Last but not least, LiFePO4 battery technology makes an active contribution to protecting humans and environment by not using toxic heavy metals such as nickel or the rare raw material cobalt. All these advantages predestine lithium-iron-phosphate battery cells as safe and particularly durable energy storage for DC UPS systems.

Battery Management System (BMS)

As already mentioned, especially lithium-ion energy storages need a battery management system (BMS) with regard to the optimization of service life and safety, which can be implemented either externally or as an integral part of the energy storage. The BMS monitors and controls the complete charging and discharging process of each energy storage cell (Figure 12).

- Battery type authentication for automatically setting the appropriate end-of-charge voltage (BMS transmits battery ID to UPS control unit)
- Charge level indicator and SOC monitoring (State of charge)
- Monitoring the cell voltages
- Current flow monitoring
- Battery health and cycle monitoring
- Temperature monitoring of the battery pack with shutdown at over- / under temperature
- Protection against cell over/under voltage, overcurrent and deep discharge
- Separation of main current path in case of a short circuit

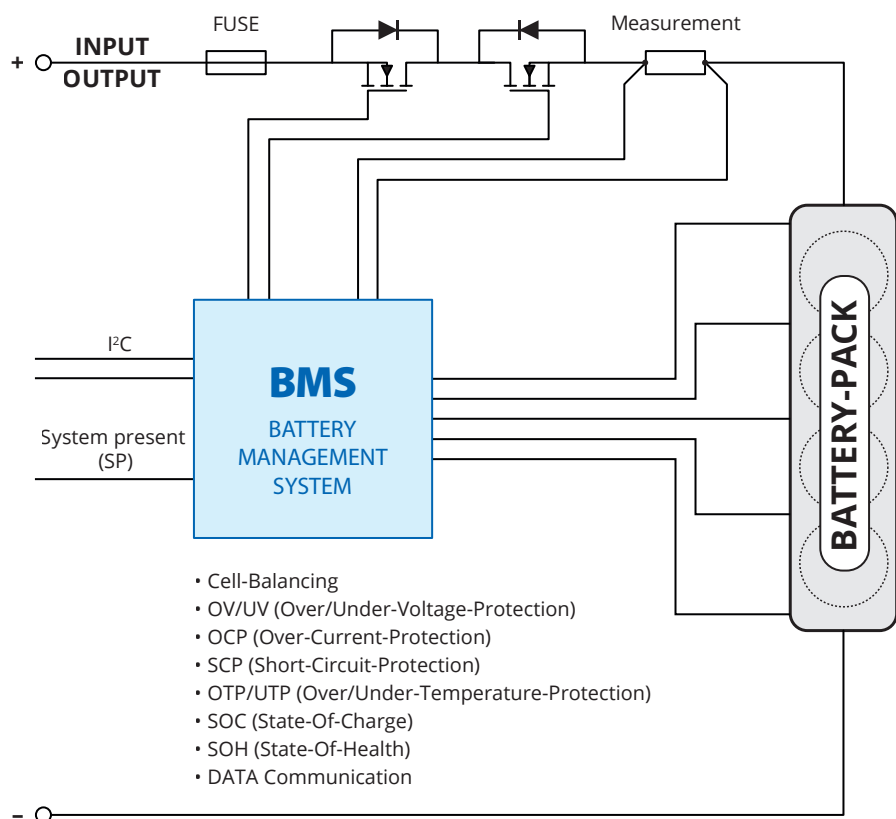

Figure 12
Block diagram BMS
Battery Management System
with battery pack.

Cell Balancing function

Another core task of the BMS (Battery Management System) is cell balancing. Within an energy storage, several single cells are connected in series to increase the nominal voltage. Due to manufacturing tolerances and different cell aging, these differ in capacity and internal resistance.

The performance and overall capacity of the lithium-ion battery pack aligns itself with the "weakest" cell in the composite, as it first reaches the voltage limit for charging, thus preventing full charge of the remaining cells (Figure 13). This negatively affects lifetime, number of cycles and capacity of energy storage devices and can ultimately even damage the battery pack.

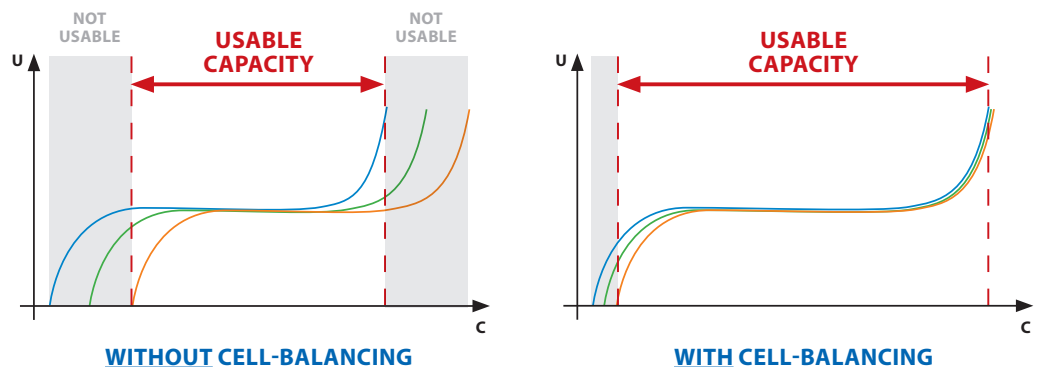

Figure 13

The cell balancing equalizes the charging curves of individual cells, so that the maximum capacity of the battery pack is achieved.

Cell balancing (active or passive) compensates these differences between the individual battery cells by a corresponding circuitry and ensures a balanced and uniform charge of all cells, so that the full capacity of the lithium-ion battery pack remains usable and avoid critical extreme situations for individual cells. Cell balancing can significantly extend the life of a battery pack.

Additional functions of BMS and energy storage

Bicker Elektronik integrates two special features into the modular DC UPS system UPSI and the associated energy storage units for additional safety and lifespan of battery packs. The Battery Relax mode and the System Present function:

Battery Relax mode extends the life of lithium-ion batteries

With the Battery Relax mode, Bicker Elektronik addresses the problem that in many DC UPS systems the battery pack is often operated for a very long time (possibly for months) to end-of-charge voltage on the charger, in order to guarantee full UPS readiness at any time. However, when lithium-ion cells remain in the end-of-charge state for such a long period of time, the lifetime of cells decreases sharply after a few months.

To protect the cells, it is therefore necessary that after a defined time the charging MOSFET is deactivated at end-of-charge. The discharge MOSFET remains active, so that a discharge is possible at any time. When discharge is detected (UPS operation after power failure), the previously deactivated charge MOSFET is immediately reconnected, so that the current flow through the body diode lasts only a few microseconds and the charger returns to the regular operating mode. Protecting the battery pack by the Relax Mode results in a significantly longer lifetime and thus an increased system availability.

System Present feature increases safety and storability of battery packs

The System Present function ensures, that the battery pack output remains deactivated (output voltage = 0 V) until it is connected to the DC UPS unit and released. As the components on the BMS board run in standby mode, this power saving feature increases the storability of (charged) battery packs.

Pure lead-tin batteries for extreme environmental conditions

For the use of DC UPS systems in environments with permanently very high or low temperatures in the range of -40°C to $+70^{\circ}\text{C}$ and high discharge currents, pure lead-tin battery cells, such as "Hawker Cyclon", are a good choice for energy storage (Figure 14).

In contrast to conventional lead acid batteries, the extremely robust cells use wounded pure lead grids (99.004%) with a tin alloy (0.65%). The optimized electrochemical processes in the valve-controlled Cyclon cells (VRLA) enable high temperature resistance and a particularly long service life.



Figure 14
Battery pack with extremely robust pure lead-tin cells.

The expected service life at trickle charge condition is specified for up to 15 years at $+20^{\circ}\text{C}$. Classic lead-gel batteries have a significantly shorter service life of max. 3-5 years at $+20^{\circ}\text{C}$. Applying the already described RGT rule, it becomes clear that, for example, at an operating temperature of $+60^{\circ}\text{C}$, a standard lead-gel battery would have reached end-of-life (EOL) after only 3 months!

The pure lead-tin batteries are particularly shock and vibration resistant and can be installed, charged and discharged in any position. A complex BMS system like for lithium-ion batteries is not necessary. However, the correct and temperature-controlled charge of such cells is demanding and requires an optimally tuned UI characteristic. Also, weight and volume are much larger compared to lithium-ion batteries.

Integrated DC UPS compact solutions

In addition to chemistry and design of individual supercaps and battery cells (cylindrical, prismatic or pouch cell), the choice of the complete DC UPS system design, consisting of energy storage, control and charging unit, also plays an important role for concrete implementation in an application. Load current, bridging time, available space and temperature range result in the capacity and technology of the energy storage device.

For system implementation particularly compact designs, which combine all components on one module or modular DC UPS systems are available. For example, the UPSIC series supercap DC UPS module (Figure 15), with a footprint of just 135 x 79.5 mm, can be integrated directly into compact robotics and automation systems to protect individual actuators/sensors or low power embedded computer systems. In addition, there is an extended version UPSIC-D in a DIN rail housing available.

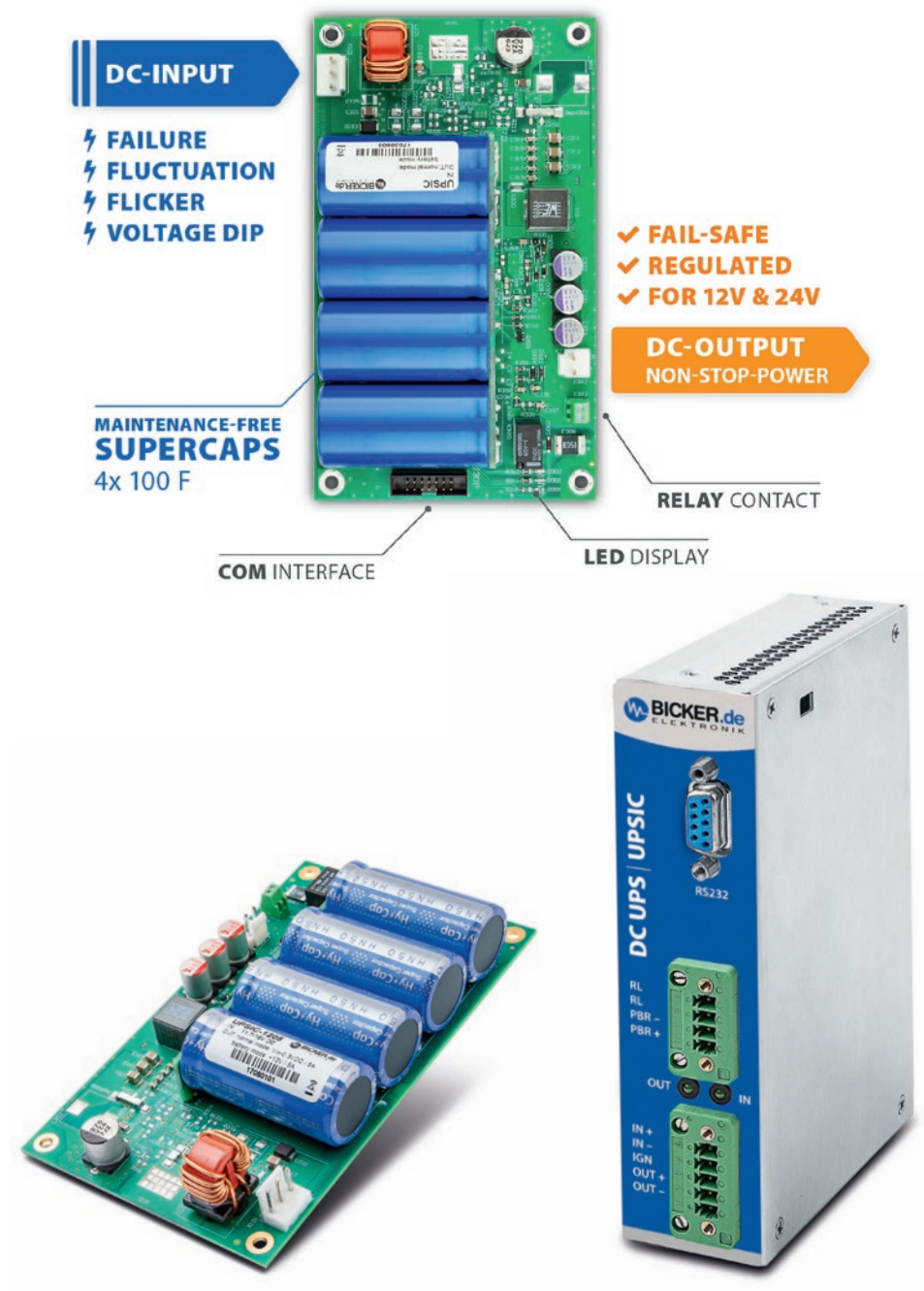

Figure 15

Compact DC UPS module as open frame version UPSIC and DIN rail version UPSIC-D.

Modular DC UPS systems for maximum flexibility

For higher energy requirements, e.g. in control and safety technology, modular and flexible DC UPS systems with separate energy storage units are available. These can be replaced at a later stage with higher capacity or alternative battery technology. In addition to fully integrated open-frame versions, manufacturers such as Bicker Elektronik also offer particularly robust and closed DIN rail versions with aluminum housing and quick-mounting brackets for applications within control cabinets (Figure 16).



Figure 16

DC UPS series UPSI-D in a robust DIN rail chassis with energy storage BP-SUC-D (Supercaps) and BP-LFP-D (LiFePO₄).

Conclusion

Keeping in mind that the requirements for an uninterruptible DC power supply are very different, an individual design-in consultation and application-specific conception together with the power supply manufacturer should always take place first. Assuming a flexibly applicable control and charging unit, it is necessary to define a suitable energy storage with regard to reliability, safety, service life, performance and costs. Here, the factors shown should be taken into account.

When assessing investment costs, consideration should be given to the total cost of ownership (TCO) over the entire useful life of an industrial or medical system. Under certain conditions allegedly cheap battery technologies can turn out after a short period of use to be a factor of uncertainty and high maintenance costs. By contrast, a well thought-out and needs-based solution can significantly reduce the overall costs for the DC UPS system without increasing the risk.

In addition, investing in effective thermal management not only extends the life of energy storage devices, but of all electronic components of an application. Combined with exceptionally deep-cycle energy storage based on maintenance-free supercaps or

safe lithium-iron-phosphate battery cells with a high-performance BMS, system designers are assured of safe, durable and cost-effective protection against power failures and power fluctuations.

Regarding available battery technologies, we will see promising new developments in the next few years, not least because of rapid developments in electromobility, which can be highly interesting for energy storage in DC UPS systems. Especially in lithium-ion technology, new anode materials such as silicon and advanced cell designs promise enormous progress in terms of performance and safety.

Manufacturers of DC UPS systems such as Bicker Elektronik will closely monitor these developments and qualify relevant components for use in new energy storage systems to provide the right solution for every requirement profile.

Authors

Apostolos Baltos & Jochen Kessens
Designing Engineers at Bicker Elektronik GmbH

Additional information

Datasheets, manuals and software for DC UPS products can be found on:
<https://www.bicker.de/index.php/eng/Products/UPS-systems/DC-UPS>

We are always available for any further questions.

We are here for you!

 **+49 (0) 906 - 705 95 - 0**

 **info@bicker.de**

 **www.bicker.de**

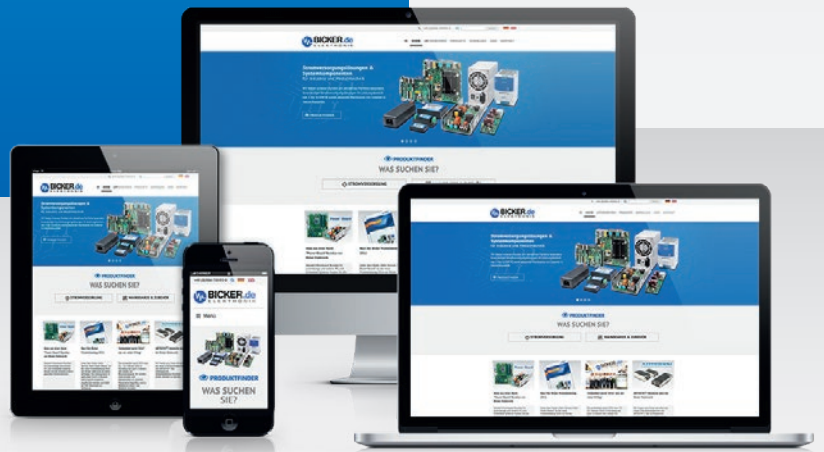

www.bicker.de

Note: Subject to errors and technical modifications! The contents of this white paper have been assembled with greatest care. All rights reserved. Copyright by Bicker Elektronik GmbH. REV001 EN | October 2018.

Bicker Elektronik GmbH

Ludwig-Auer-Straße 23
86609 Donauwörth · Germany
Tel. +49 (0) 906 - 705 95-0
Fax +49 (0) 906 - 705 95-55
E-Mail info@bicker.de