

NOTE: THE ORIGINAL DESIGN OF THIS MODEL ENGINE WAS MADE BY Mr. H.E.SCHEELE, AND PUBLISHED IN THE DUTCH MAGAZINE "ONDER STOOM", MAGAZINE NUMBERS 244 TO 255

TITLE
**DARJEELING HIMALAYAN RAILWAY "B-CLASS"
 STEAM LOCOMOTIVE**

DRAWING CONTENTS
GENERAL ARRANGEMENT

PROJECT No
JDW DRAUGHTING SERVICES
 J.A.M. DE WAAL, 12 BRIGHTWELL STREET PAPAURA 2110,
 NEW ZEALAND. PHONE: 0064 09 2988815. MOB: 0211791000
 E-MAIL: dewaal@xtra.co.nz.

PROJECTION
JDWDS
 DATE **DECEMBER 2014**
 SHEET:01 OF 09

MODEL SCALE: 1:13.3 GAUGE 45mm
 DWG SCALE: NTS @A3 OR AS SHOWN
 Copyright © J.A.M. DE WAAL PAPAURA NZ
A3 No: DHR-B-45-01

QTY.	PART NUMBER
1	DHR-B-45-1-01-RH-SIDE FRAME
1	DHR-B-45-1-02-LH-SIDE FRAME
2	DHR-B-45-1-03-BUFFER BEAM
1	DHR-B-45-1-04-REAR BOILER SUPPORT
1	DHR-B-45-1-05-FRONT BOILER SUPPORT
1	DHR-B-45-1-06-FRONT FOOT PLATE
4	DHR-B-45-1-07-BRONZE AXLE BEARING
1	DHR-B-45-1-08-LH-CYLINDER
1	DHR-B-45-1-09-RH-CYLINDER
2	DHR-B-45-1-10-STEAM VALVE PORT BLOCK
1	DHR-B-45-1-11-LH-VALVE BOX
1	DHR-B-45-1-12-RH-VALVE BOX
2	DHR-B-45-1-13-VALVE BOX COVER
2	DHR-B-45-1-14-CYLINDER FRONT COVER
2	DHR-B-45-1-15-CYLINDER REAR COVER
2	DHR-B-45-1-16-VALVE BOX REAR COVER
2	DHR-B-45-1-17-CROSS HEAD GUIDE
4	DHR-B-45-1-18-STEAM IP-OP CONNECTOR
1	DHR-B-45-1-19-FOOT PLATE
1	DHR-B-45-1-20-FOOT PLATE -RIGHT RIM
1	DHR-B-45-1-21-FOOT PLATE LEFT RIM
1	DHR-B-45-1-22-FOOT PLATE REAR RIM
4	DHR-B-45-1-23-FOOT PLATE MOUNTING BRACKET
2	DHR-B-45-1-24-VALVE REVERSING SHAFT BRACKET
2	DHR-B-45-1-25-VALVE REVERSING SHAFT HOLDING BRACKET
2	DHR-B-45-1-26-ROCKER PLATE BRACKET
2	DHR-B-45-1-27-BUFFER
1	DHR-B-45-1-28-SAND BOX
1	DHR-B-45-1-29-SAND BOXHINGE PLATE
1	DHR-B-45-1-30-SAND BOX LID
1	DHR-B-45-1-31A-CYLINDER EXHAUST CROSS PIPE CENTER CON
4	DHR-B-45-1-31B-CYLINDER EXHAUST CROSS PIPE
4	DHR-B-45-1-31C-CYLINDER EXHAUST CROSS PIPE NUT
1	DHR-B-45-1-32A-CYLINDER INLET CROSS PIPE CENTER CONNECTOR
1	DHR-B-45-1-32B-CYLINDER INLET DELIVERY PIPE
1	DHR-B-45-1-33-CYLINDER INLET DELIVERY PIPE - GREASER CON
1	DHR-B-45-1-34-CYLINDER INLET PIPE NUT
1	DHR-B-45-1-35-RH-WIND SHIELD
1	DHR-B-45-1-36-LH-WIND SHIELD
1	DHR-B-45-1-37-PIPE FLANGE
1	DHR-B-45-1-37-PIPE FLANGE
2	DHR-B-45-1-38-REAR AND FRONT STEP MOUNTING PLATE
1	DHR-B-45-1-39-LEFT REAR STEP ANGLE
1	DHR-B-45-1-40-RIGHT REAR STEP ANGLE
1	DHR-B-45-1-41-LEFT FRONT STEP ANGLE
1	DHR-B-45-1-42-RIGHT FRONT STEP ANGLE
2	DHR-B-45-1-43-STEP PLATE ANGLE BRACKET
2	DHR-B-45-1-44-STEP PLATE
1	DHR-B-45-1-45-LH FRONT HAND RAIL
1	DHR-B-45-1-46-RH FRONT HAND RAIL
1	DHR-B-45-1-47-LUBRICATOR
1	DHR-B-45-1-48-SCREW CONNECTOR
1	DHR-B-45-1-49-BURNER WICK HOLDER
1	DHR-B-45-1-50-BURNER FUEL TANK REAR
6	DHR-B-45-1-51-BURNER WICK TUBE
1	DHR-B-45-1-52-BURNER FILL PIPE
1	DHR-B-45-1-53-MOUNTING RING
1	DHR-B-45-1-54-CONNECTING TUBE
1	DHR-B-45-1-55-BURNER FUEL TANK FRONT
1	DHR-B-45-1-56-BURNER FUEL TANK BRACKET
1	DHR-B-45-1-57-OVERFLOW TUBE
QTY.	PART NUMBER
2	DHR-B-45-2-01-PISTON ROD
2	DHR-B-45-2-02-PISTON
2	DHR-B-45-2-03-VALVE ROD
2	DHR-B-45-2-04-VALVE NUT
2	DHR-B-45-2-05-VALVE
1	DHR-B-45-2-06-RH-ROCKER PLATE
1	DHR-B-45-2-06-RH-ROCKER PLATE
1	DHR-B-45-2-07-LH-ROCKER PLATE
1	DHR-B-45-2-07-LH-ROCKER PLATE
4	DHR-B-45-2-08-ROCKER PLATE SPACER
4	DHR-B-45-2-09-ROCKER PLATE THREADED SPACER
1	DHR-B-45-2-14-LH-CROSSHEAD
1	DHR-B-45-2-15-RH-CROSSHEAD
2	DHR-B-45-2-17-CONNECTION ROD
2	DHR-B-45-2-18-PISTON CONNECTION ROD
2	DHR-B-45-2-19-EXCENTRIC CONNECTION ROD
2	DHR-B-45-2-20-EXCENTRIC CONNECTION CRANK
2	DHR-B-45-2-21-CONTRA CRANK
2	DHR-B-45-2-22-CRANK PIN
2	DHR-B-45-2-23-SPACER
4	DHR-B-45-2-24-CRANK
4	DHR-B-45-2-25-WHEEL
2	DHR-B-45-2-26-WHEEL AXLE
1	DHR-B-45-2-28-LONG VALVE REVERSING SHAFT
2	DHR-B-45-2-29-VALVE REVERSING SHAFT LINK PLATE
2	DHR-B-45-2-30-SHORT VALVE REVERSING SHAFT

QTY.	PART NUMBER
1	DHR-B-45-2-31-VALVE REVERSING SHAFT BUSH-1
1	DHR-B-45-2-32-VALVE REVERSING SHAFT BUSH-2
3	DHR-B-45-2-33-VALVE REVERSING SHAFT CRANK PLATE
2	DHR-B-45-2-34-VALVE REVERSING LINK
2	DHR-B-45-2-35-VALVE CON ROD
2	DHR-B-45-2-36-VALVE AHEAD LINK
2	DHR-B-45-2-37-VALVE LINK-1
2	DHR-B-45-2-38-VALVE ROD YOKE
1	DHR-B-45-2-40-DIRECTION CONTROL HANDLE
2	DHR-B-45-2-41-M3x8-CROSS HEAD CON ROD SHAFT
4	DHR-B-45-2-42-M3x5-CROSS HEAD LOWER LINK SHAFT
7	DHR-B-45-2-43-M3x4-LOWER LINK-DROP LINK SHAFT
2	DHR-B-45-2-44-M3x8-VALVE CROSSHEAD-DROP LINK SHAFT
4	DHR-B-45-2-45-M3x5.5-ROCKER ARM SHAFT
2	DHR-B-45-2-46-M3x6-ROCKER ARM TOP BOLT
2	DHR-B-45-2-47-M3x8-ROCKER ARM BOTTOM BOLT
2	DHR-B-45-2-48-M3x4-LOWER LINK-ECCENTRIC ROD SHAFT
2	DHR-B-45-2-49-M3x6-ECCENTRIC CRSANK-ECC.ROD SHAFT
QTY.	PART NUMBER
1	DHR-B-45-3-01-EXTERNAL BOILER SHELL
1	DHR-B-45-3-02-INTERNAL BOILER SHELL
1	DHR-B-45-3-03-SMOKE BOX FRONT
1	DHR-B-45-3-04-INTERNAL BOILER FRONT
2	DHR-B-45-3-05-FLAME PIPE
1	DHR-B-45-3-06-DOME RING
1	DHR-B-45-3-07-SUPPORT RING
1	DHR-B-45-3-08-STEAM DELIVERY PIPE
1	DHR-B-45-3-09A-STEAM DIVIDER BUSH
1	DHR-B-45-3-09B-STEAM DIVIDER
1	DHR-B-45-3-10-WATER LEVEL METER BUSH
1	DHR-B-45-3-11-BOILER BACK HEAD TOP
1	DHR-B-45-3-12-BOILER BACK HEAD BOTTOM
1	DHR-B-45-3-13-FIRE BOX TOP PLATE
1	DHR-B-45-3-18-SCREW END
1	DHR-B-45-3-19-SMOKE BOX WATER TUBE-A
1	DHR-B-45-3-20-SMOKE BOX WATER TUBE-B
1	DHR-B-45-3-21-SMOKE BOX WATER TUBE-C
1	DHR-B-45-3-22-FIRE BOX WALL
1	DHR-B-45-3-23-FIRE BOX FRONT WALL
1	DHR-B-45-3-24-FIRE BOX REAR WAL
1	DHR-B-45-3-25-FIRE BOX COAL FEED LID
1	DHR-B-45-3-26-SADDLE TANK
1	DHR-B-45-3-27-WATER FILLER
1	DHR-B-45-3-28-WATER FILLER LID
2	DHR-B-45-3-29-PIPE FLANGE
1	DHR-B-45-3-30-EXHAUST RING
1	DHR-B-45-3-31-EXHAUST NIPPLE
1	DHR-B-45-3-32-EXHAUST TUBE
1	DHR-B-45-3-33-EXHAUST TUBE NOZZLE
1	DHR-B-45-3-34-BLOWER NIPPLE
1	DHR-B-45-3-35-BLOWER RING
1	DHR-B-45-3-36-BLOWER TUBE
1	DHR-B-45-3-37-BLOWER TUBE NOZZLE
1	DHR-B-45-3-38-SUPPORT BRACKET
1	DHR-B-45-3-39-DOME
1	DHR-B-45-3-40-CHIMNEY
1	DHR-B-45-3-41-RH-WATER PIPE
1	DHR-B-45-3-42-LH-WATER PIPE
1	DHR-B-45-3-43A-SMOKE BOX DOOR
4	DHR-B-45-3-43B-SMOKE BOX DOORSTAND OFF
1	DHR-B-45-3-43C-SMOKE BOX HINGE
1	DHR-B-45-3-43D-SMOKE DOOR SCREW LOCK
1	DHR-B-45-3-44-BLOWER PIPE NUT
1	DHR-B-45-3-45-BLOWER PIPE
1	DHR-B-45-3-46-BLOWER PIPE EXTENTION
1	DHR-B-45-3-47-REGULATOR PIPE NUT
1	DHR-B-45-3-48-SAFETY VALVE BODY
1	DHR-B-45-3-49-PRESSURE GAUGE CONNECTOR
1	DHR-B-45-3-50-PRESSUE GAUGE CONNECTOR SCREW
1	DHR-B-45-3-51-SAFETY VALVE STEM
1	DHR-B-45-3-52-SAFETY VALVE SPRING
1	DHR-B-45-3-53-LAMP HOLDER
1	DHR-B-45-3-55-LAMPHOLDER FRONT SEAT
1	DHR-B-45-3-56-LAMP HOLDER FRONT BRACKET
2	DHR-B-45-3-57-LAMP HOLDER FRONT BRACKET STAY
2	DHR-B-45-3-58-LAMPHOLDER HAND GRIP
2	DHR-B-45-3-59-REGULATOR VALVE BODY
2	DHR-B-45-3-60-REGULATOR VALVE STEM
2	DHR-B-45-3-61-REGULATOR VALVE STEM GUIDE
2	DHR-B-45-3-62-REGULATOR VALVE STEM SEAL
2	DHR-B-45-3-63-REGULATOR VALVE HAND WHEEL
1	DHR-B-45-3-64-PRESSURE GAUGE
1	DHR-B-45-3-65-PRESSURE GAUGE SCREW CONNECTOR
1	DHR-B-45-3-66-WATER FILLER RING
1	DHR-B-45-3-67-WATER FILLER SCREW TOP

QTY.	PART NUMBER
1	DHR-B-45-4-01-CABIN OUTER SIDE PLATE
1	DHR-B-45-4-01-CABIN OUTER SIDE PLATE
1	DHR-B-45-4-02-CABIN OUTER FRONT PLATE
2	DHR-B-45-4-03-CABIN CORNER STIFFENER
2	DHR-B-45-4-04-CABIN COAL BUNKER SIDE PLATE
1	DHR-B-45-4-05-CABIN COAL BUNKER FRONT PLATE
1	DHR-B-45-4-06-CABIN COAL BUNKER BOTTOM PLATE
1	DHR-B-45-4-07-CABIN FRONT PLATE
1	DHR-B-45-4-08-CABIN REAR PLATE
1	DHR-B-45-4-09A-CABIN FRONT PLATE CORNER STIFFENER
2	DHR-B-45-4-09B-CABIN FRONT PLATE CORNER STIFFENER
1	DHR-B-45-4-09C-CABIN FRONT PLATE CORNER STIFFENER
3	DHR-B-45-4-10-CABIN ROOF STIFFENER
1	DHR-B-45-4-11-CABIN ROOF
1	DHR-B-45-4-12-CABIN RH-COAL BUNKER BOTTOM PLATE
1	DHR-B-45-4-13-CABIN LH-COAL BUNKER BOTTOM PLATE
2	DHR-B-45-4-14-CABIN HAND RAIL
4	DHR-B-45-4-15-CABIN MOUNTING ANGLE BRACKET
2	DHR-B-45-4-16-FRONT WINDOWS +SURROUND
1	DHR-B-45-4-17-REAR LAMP HOLDER
1	DHR-B-45-4-18-LAMPHOLDER REAR SEAT
QTY.	PART NUMBER
18	DHR-B-45-M15-NUT
16	DHR-B-45-M15x2 RIVET
34	DHR-B-45-M15x5 P-HEAD SCREW
2	DHR-B-45-M15x7 GRUB SCREW
5	DHR-B-45-M2-NUT
4	DHR-B-45-M2x2.5 GRUB SCREW
2	DHR-B-45-M2x4 C-SINK SCREW
9	DHR-B-45-M2x4 P-HEAD SCREW
14	DHR-B-45-M2x6 P-HEAD SCREW
8	DHR-B-45-M2x8 P-HEAD SCREW
8	DHR-B-45-M2x10 P-HEAD SCREW
8	DHR-B-45-M2x21 P-HEAD SCREW
6	DHR-B-45-M3-NUT
4	DHR-B-45-M3x2.5 GRUB SCREW
4	DHR-B-45-M3x4 GRUB SCREW
16	DHR-B-45-M3x5 P-HEAD SCREW
4	DHR-B-45-M3x6 P-HEAD SCREW
6	DHR-B-45-M3x10 C-SINK SCREW
22	DHR-B-45-M3x10 P-HEAD SCREW
1	DHR-B-45-RAIL TRACK 045mm (1.77in)

MATERIAL ABBREVIATIONS:
CU = COPPER
BRS = BRASS.
BRZ = BONZE OR GUN METAL
MS = MILD STEEL/BRIGHT MILD STEEL.
S/S = STAINLESS OF SILVER STEEL.
SPS = SPRING STEEL.
SYN = SYNTHETIC MATERIAL SUCH AS: NYLON, VETON, TEFLON, RUBBER

NOTES:
0. ALL DRAWINGS ARE IN METRIC MEASUREMENTS.
1. ALL ENGINEERING PRACTICES SHALL BE APPLIED WITH REGARDS TO HOLE AND SHAFT TOLERANCES.
2. WHERE SCREWS OR BOLTS ARE USED THE CLEARANCE HOLES SHALL BE APPROXIMATELY 5% TO 8% LARGER THAN THE MATCHING TAPPED HOLE.
3. PREFERABLY ALL TAPPED HOLES, SCREWS, BOLTS AND NUTS TO BE METRIC FINE (MF).
4. THE MATERIALS SPECIFIED ON THE DRAWINGS ARE INDICATIVE ONLY, THE BUILDER CAN CHOOSE MATERIALS WHICH COULD BE BETTER SUITED FOR THE PART(S)/COMPONENT.
5. BRASS BUSHES CAN BE REPLACED WITH BRONZE BUSHES IF SO PREFERRED OR WITH BALL BEARINGS IF SO DESIRED.
6. PISTON RING(S), IF APPLICABLE, TO BE MADE OUT OF EITHER TEFLON OR VETON OR NYLON (PISTON RING NOT SHOWN ON DRAWINGS).
7. WHERE PARTS ARE SOLDERED TOGETHER AND ALSO RIVETS OR SCREWS ARE SHOWN THEN THE RIVETS/SCREWS CAN BE OMITTED.
8. ALL BOILER PARTS WHICH ARE UNDER STEAM PRESSURE SHALL BE HARD/SILVER SOLDERED.
9. ALL PARTS WHICH FORMS PART OF A WATER CONTAINER CAN BE SOLDERED USING SOFT SOLDER.
10. ALL PARTS WHICH DO NOT HAVE SIGNIFICANT FORCES APPLIED CAN BE SOLDERED TOGETHER USING SOFT SOLDER.
11. THE BUILDER SHOULD INQUIRE, AT THE APPROPRIATE AUTHORITIES, WHETHER OR NOT THE BOILER SHOULD BE TESTED AND ISSUED WITH A CERTIFICATE OF COMPLIANCE BEFORE THE BOILER IS BEING USED.
12 THE BOILER SHOULD BE TESTED TO TWICE THE MAXIMUM WORKING PRESSURE USING WATER PRESSURE.

OTHER ABBREVIATIONS:
SA-xx-xx = SUB-ASSEMBLY-xx-xx

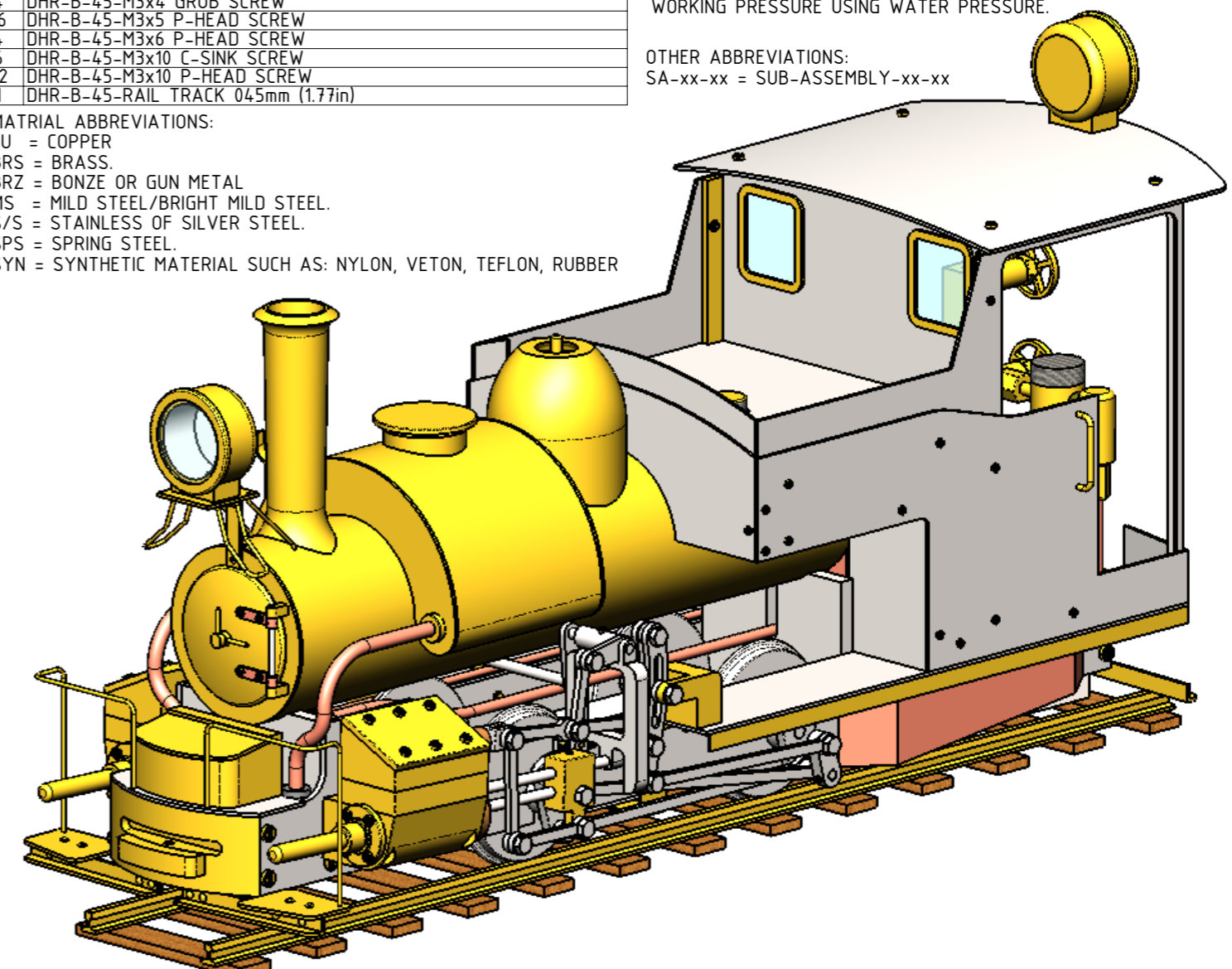

TITLE
DARJEELING HIMALAYAN RAILWAY "B-CLASS" STEAM LOCOMOTIVE

DRAWING CONTENTS
ISOMETRIC VIEW, NOTES AND BILL OF MATERIALS

PROJECT No
JDW DRAUGHTING SERVICES
J.A.M. DE WAAL, 12 BRIGHTWELL STREET PAKAPURA 2110.
NEW ZEALAND. PHONE: 0064 09 2988815. MOB: 0211791000
E-MAIL: dewaal@xtra.co.nz.

PROJECTION
JDWDS
DATE **DECEMBER 2014**
MODEL SCALE: 1:13.3 GAUGE 45mm
DWG SCALE: NTS @A3 OR AS SHOWN
Copyright © J.A.M. DE WAAL PAKAPURA NZ
SHEET:02 OF 09 **A3** No: **DHR-B-45-02**

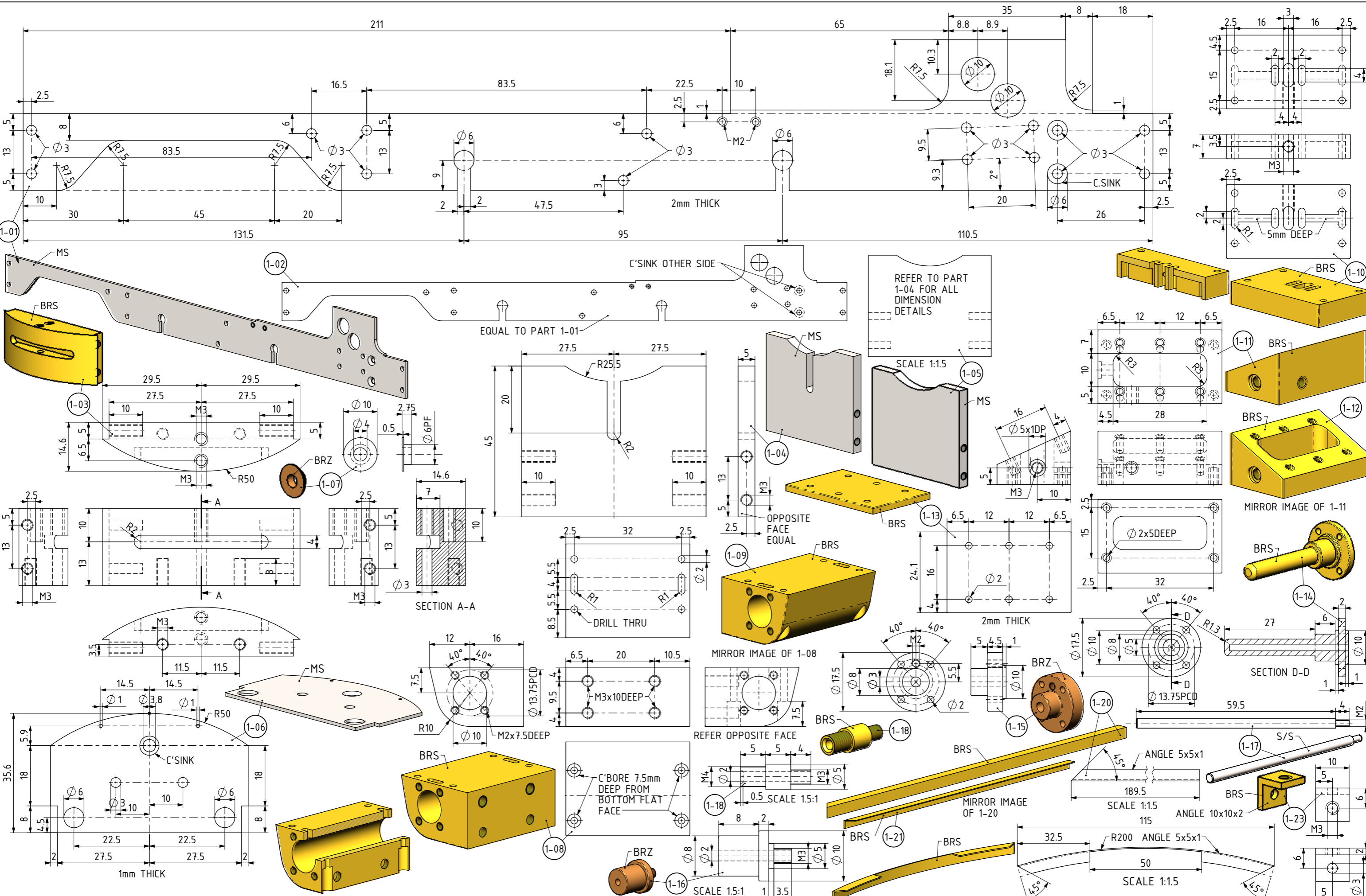

TITLE
**DARJEELING HIMALAYAN RAILWAY "B-CLASS"
 STEAM LOCOMOTIVE**

DRAWING CONTENTS
PARTS AND ASSEMBLIES

PROJECT No
 JDW DRAUGHTING SERVICES
 J.A.M. DE WAAL, 12 BRIGHTWELL STREET PAPA KURA 2110.
 NEW ZEALAND. PHONE: 0064 09 2988815. MOB: 0217119000
 E-MAIL: dewaal@xtra.co.nz.

PROJECTION
 JDWDS
 DATE: DECEMBER 2014
 SHEET: 03 OF 09

MODEL SCALE: 1:13.3 GAUGE 45mm
 DWG SCALE: 1:1 @ A3 OR AS SHOWN
 Copyright © J.A.M. DE WAAL PAPA KURA NZ
 No: DHR-B-45-03

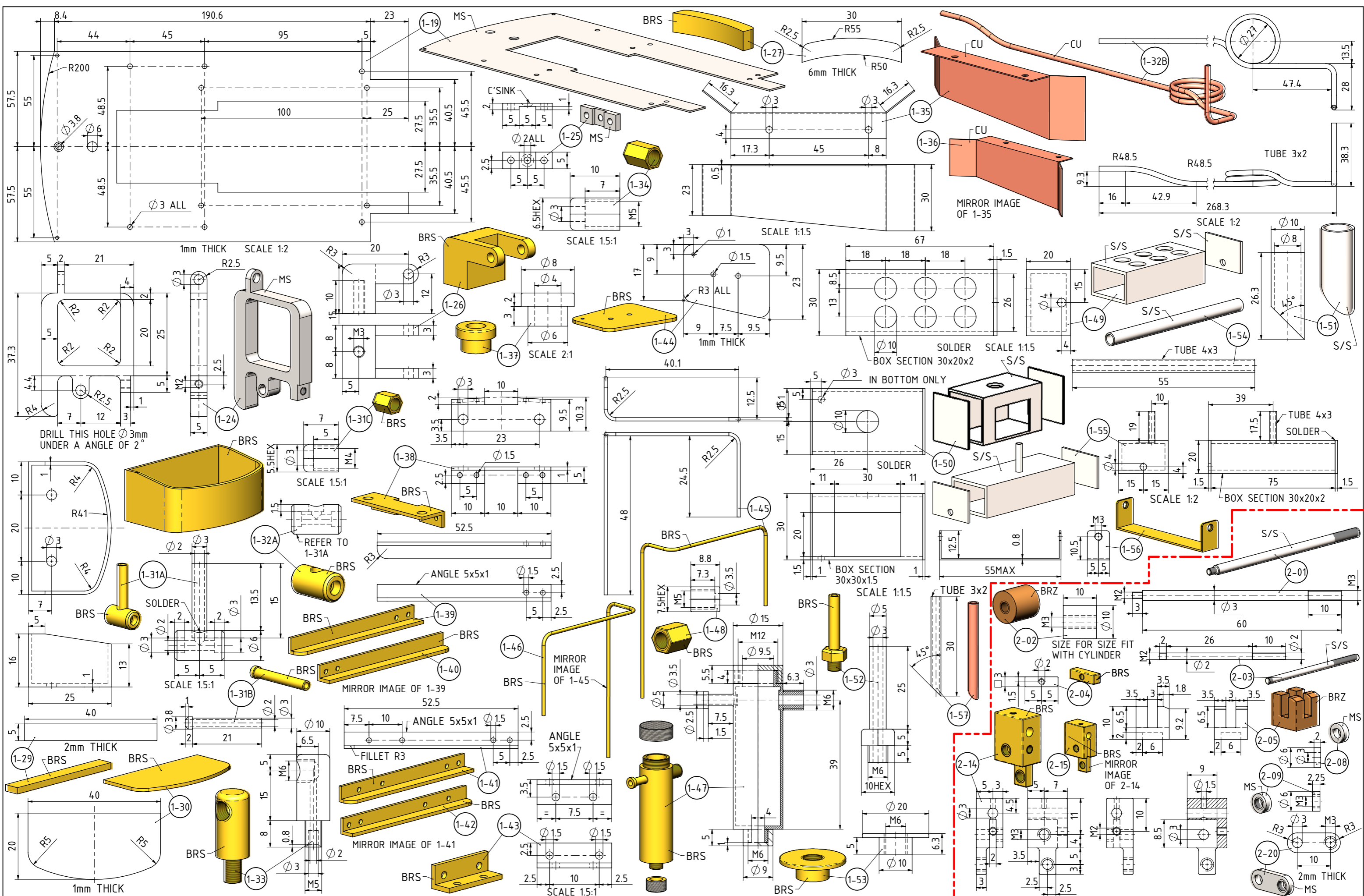

TITLE
**DARJEELING HIMALAYAN RAILWAY "B-CLASS"
 STEAM LOCOMOTIVE**

DRAWING CONTENTS
PARTS AND ASSEMBLIES

PROJECT No
JDW DRAUGHTING SERVICES
 J.A.M. DE WAAL, 12 BRIGHTWELL STREET PAPAURA 2110,
 NEW ZEALAND. PHONE: 0064 09 2988815. MOB: 0211791000
 E-MAIL: dewaal@xtra.co.nz.

PROJECTION
JDWDS
 DATE **DECEMBER 2014**

MODEL SCALE: 1:13.3 GAUGE 45mm
 DWG SCALE: 1:1 @A3 OR AS SHOWN
 Copyright © J.A.M. DE WAAL PAPAURA NZ
SHEET:04 OF 09 A3 No: DHR-B-45-04

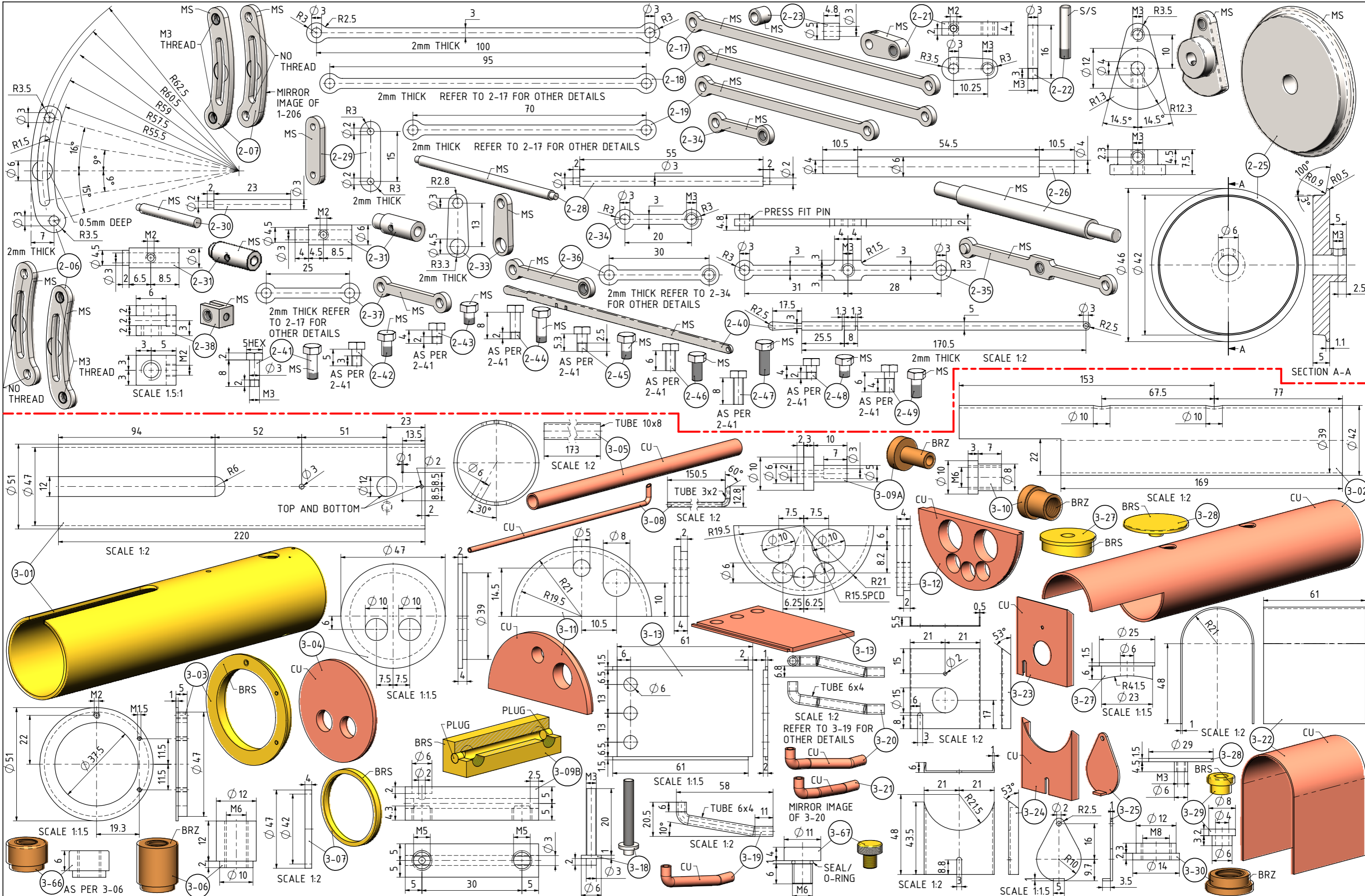

TITLE
DARJEELING HIMALAYAN RAILWAY "B-CLASS" STEAM LOCOMOTIVE

DRAWING CONTENTS
PARTS AND ASSEMBLIES

PROJECT No
JDW DRAUGHTING SERVICES
 J.A.M. DE WAAL, 12 BRIGHTWELL STREET PAKAPURA 2110.
 NEW ZEALAND. PHONE: 0064 09 2988815. MOB: 0211791000
 E-MAIL: dewaal@xtra.co.nz.

PROJECTION
JDWDS
 DATE **DECEMBER 2014**

MODEL SCALE: 1:13.3 GAUGE 45mm
 DWG SCALE: 1:1 @A3 OR AS SHOWN
 Copyright © J.A.M. DE WAAL PAKAPURA NZ
 SHEET:05 OF 09 **A3** No: **DHR-B-45-05**

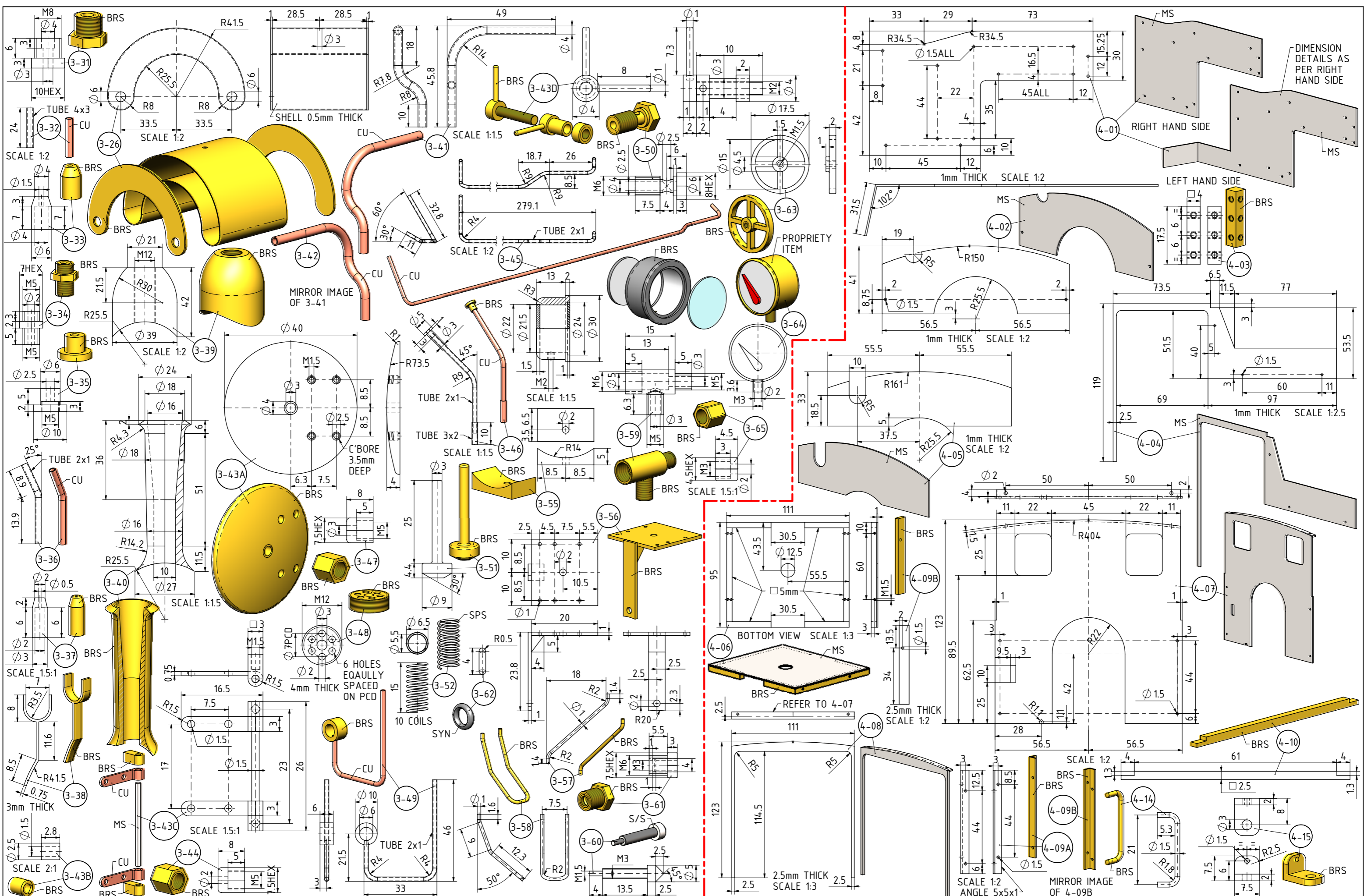

TITLE
DARJEELING HIMALAYAN RAILWAY "B-CLASS" STEAM LOCOMOTIVE

DRAWING CONTENTS
PARTS AND ASSEMBLIES

PROJECT No
JDW DRAUGHTING SERVICES
 J.A.M. DE WAAL, 12 BRIGHTWELL STREET PAPAOKURA 2110.
 NEW ZEALAND. PHONE: 0664 09 2988815. MOB: 0211791000
 E-MAIL: dewaal@xtra.co.nz.

PROJECTION
JDWDS
 DATE **DECEMBER 2014**

MODEL SCALE: 1:13.3 GAUGE 45mm
 DWG SCALE: 1:1 @A3 OR AS SHOWN
 Copyright © J.A.M. DE WAAL PAPAOKURA NZ
SHEET:06 OF 09 A3 No: DHR-B-45-06

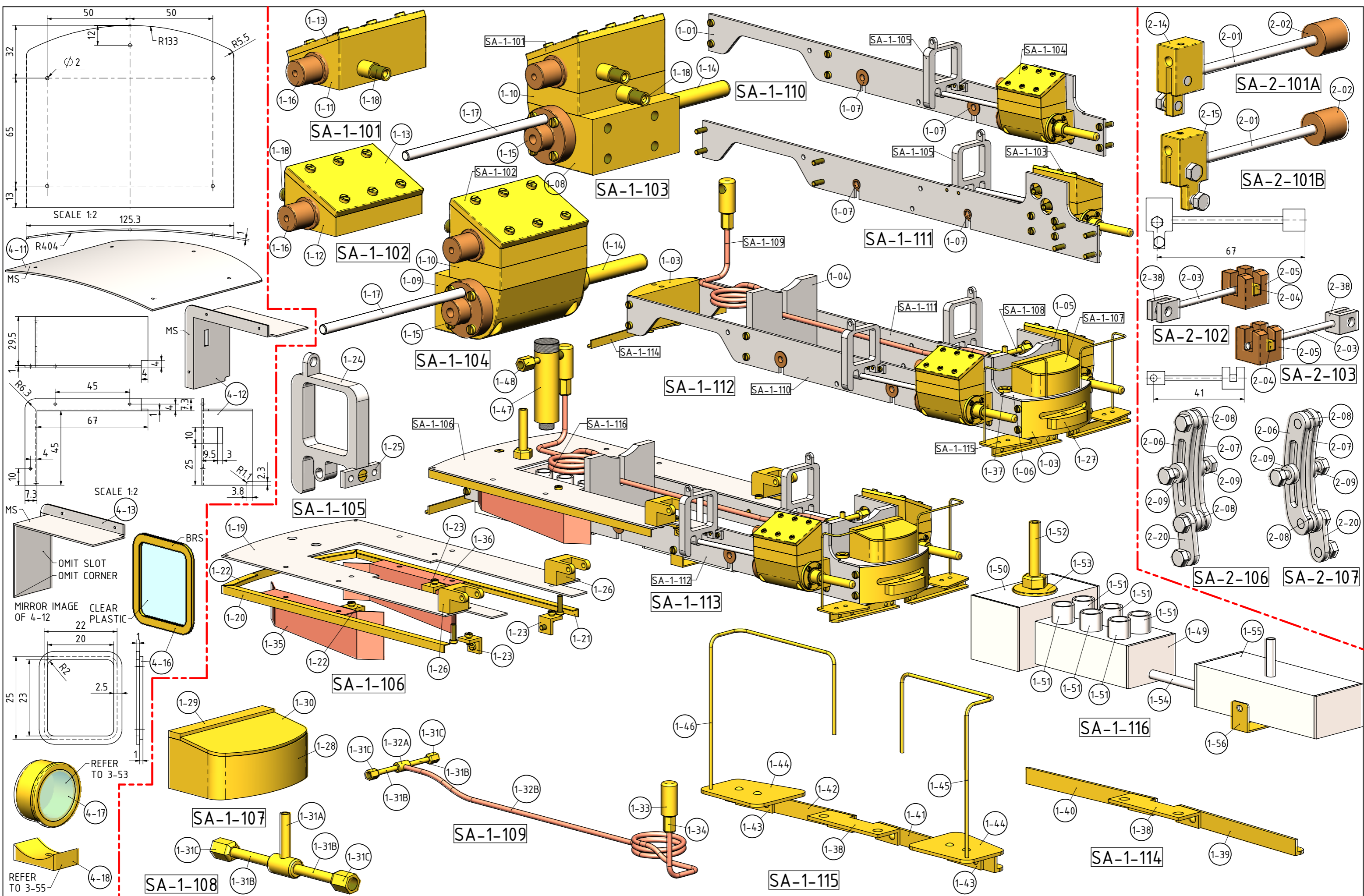

TITLE
DARJEELING HIMALAYAN RAILWAY "B-CLASS" STEAM LOCOMOTIVE

DRAWING CONTENTS
PARTS AND ASSEMBLIES

PROJECT No
JDW DRAUGHTING SERVICES
 J.A.M. DE WAAL, 12 BRIGHTWELL STREET PAPA KURA 2110.
 NEW ZEALAND. PHONE: 0064 09 2988815. MOB: 0211791000
 E-MAIL: dewaal@xtra.co.nz.

PROJECTION
JDWDS
 DATE **DECEMBER 2014**

MODEL SCALE: 1:13.3 GAUGE 45mm
 DWG SCALE: 1:1 @A3 OR AS SHOWN
 Copyright © J.A.M. DE WAAL PAPA KURA NZ
SHEET:07 OF 09 A3 No: DHR-B-45-07

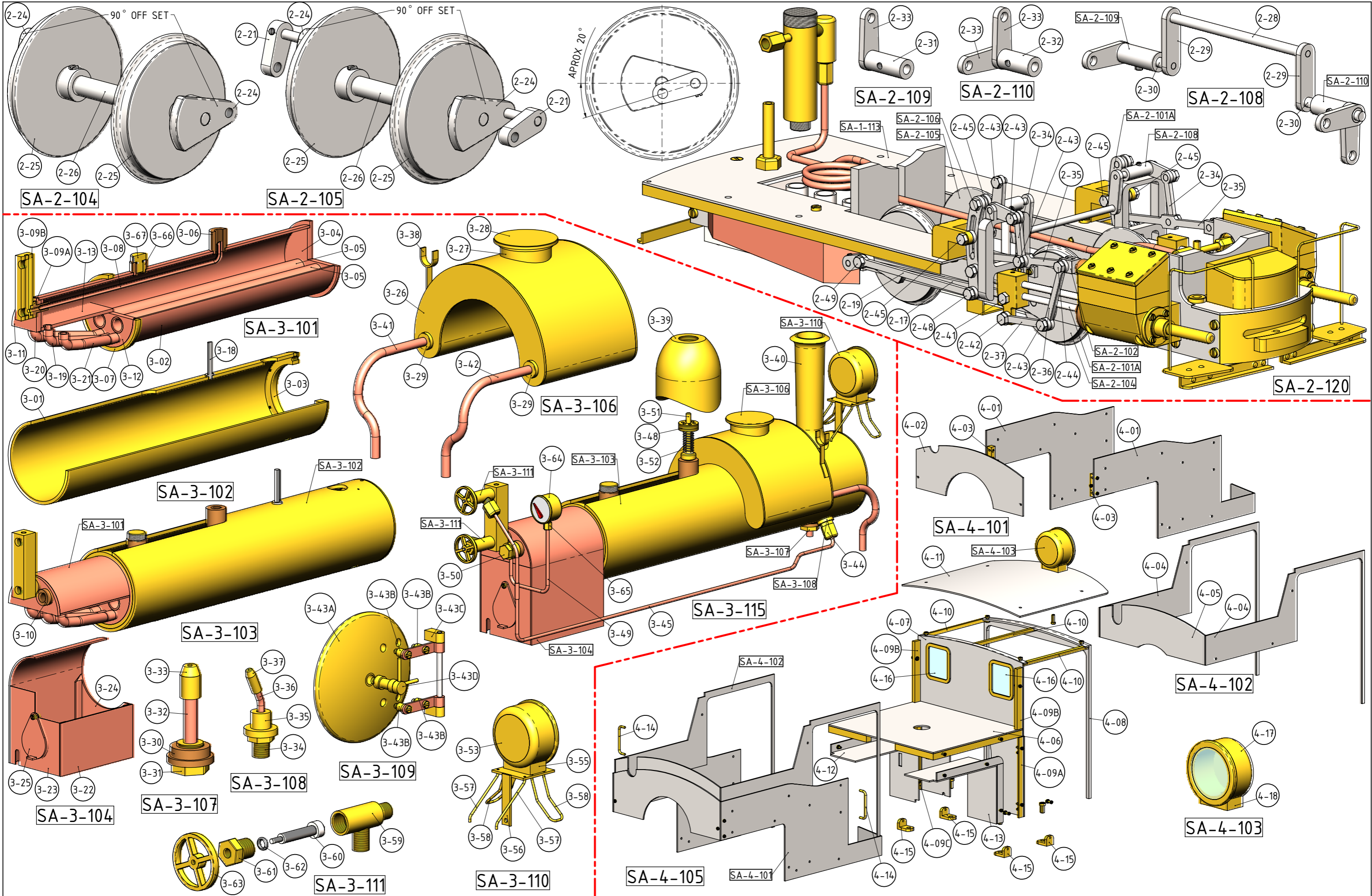

TITLE
**DARJEELING HIMALAYAN RAILWAY "B-CLASS"
 STEAM LOCOMOTIVE**

DRAWING CONTENTS
ASSEMBLIES

PROJECT No
JDW DRAUGHTING SERVICES
 J.A.M. DE WAAL, 12 BRIGHTWELL STREET PAPAOKURA 2110,
 NEW ZEALAND. PHONE: 0064 09 2988815. MOB: 0211791000
 E-MAIL: dewaal@xtra.co.nz.

PROJECTION
JDWDS
 DATE **DECEMBER 2014**

MODEL SCALE: 1:13.3 GAUGE 45mm
 DWG SCALE: 1:1 @A3 OR AS SHOWN
 Copyright © J.A.M. DE WAAL PAPAOKURA NZ
 SHEET:08 OF 09 **A3** No: **DHR-B-45-08**

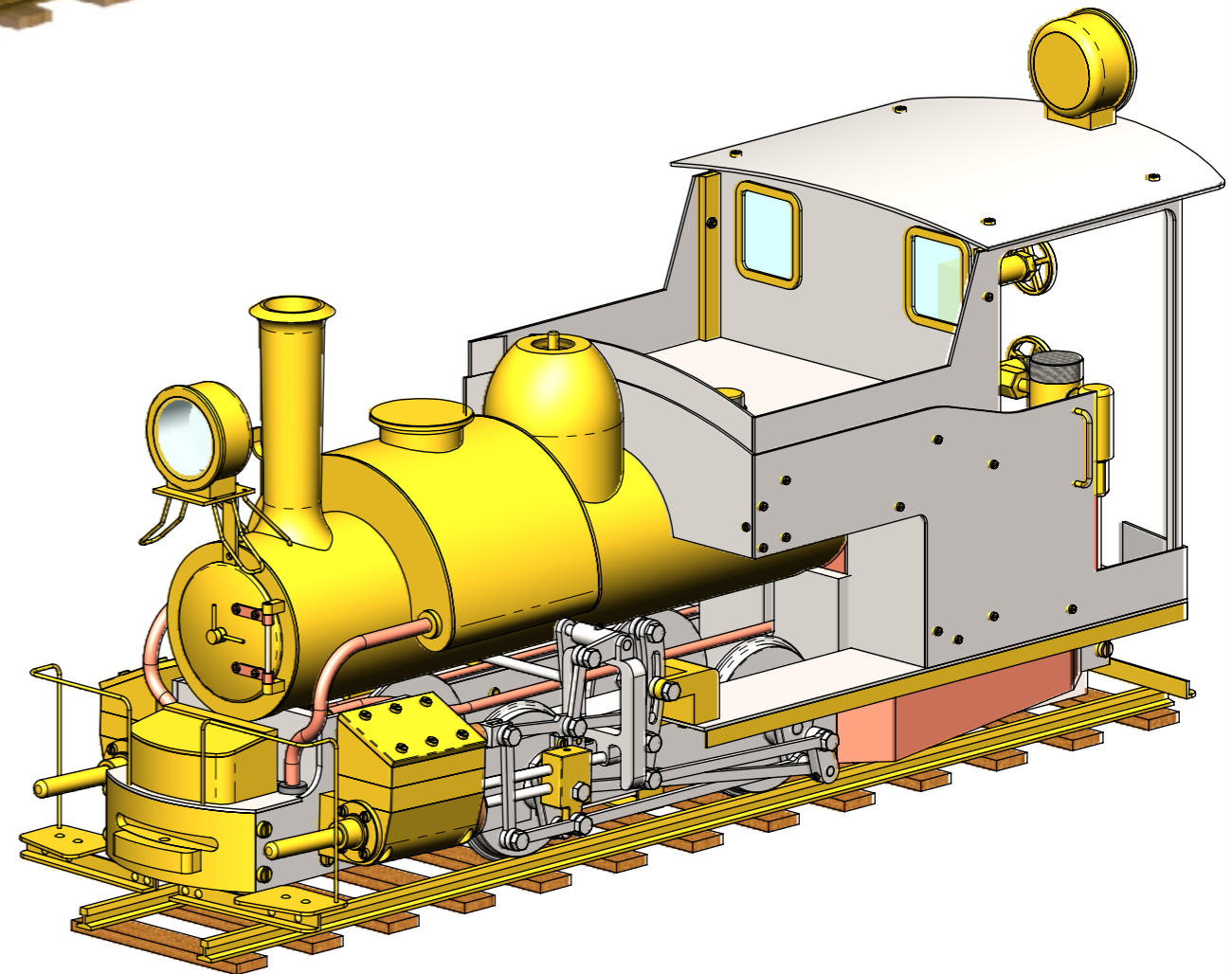
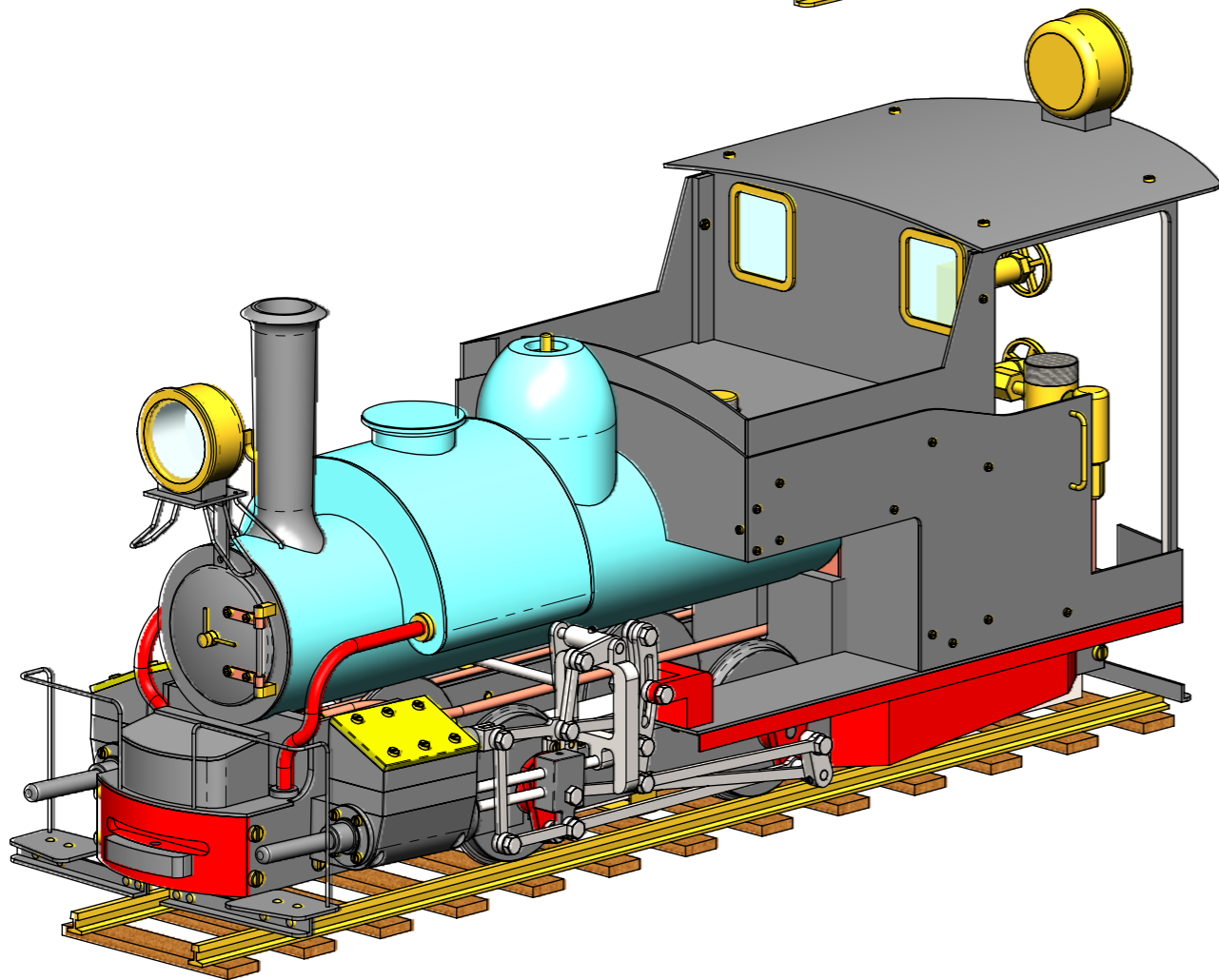
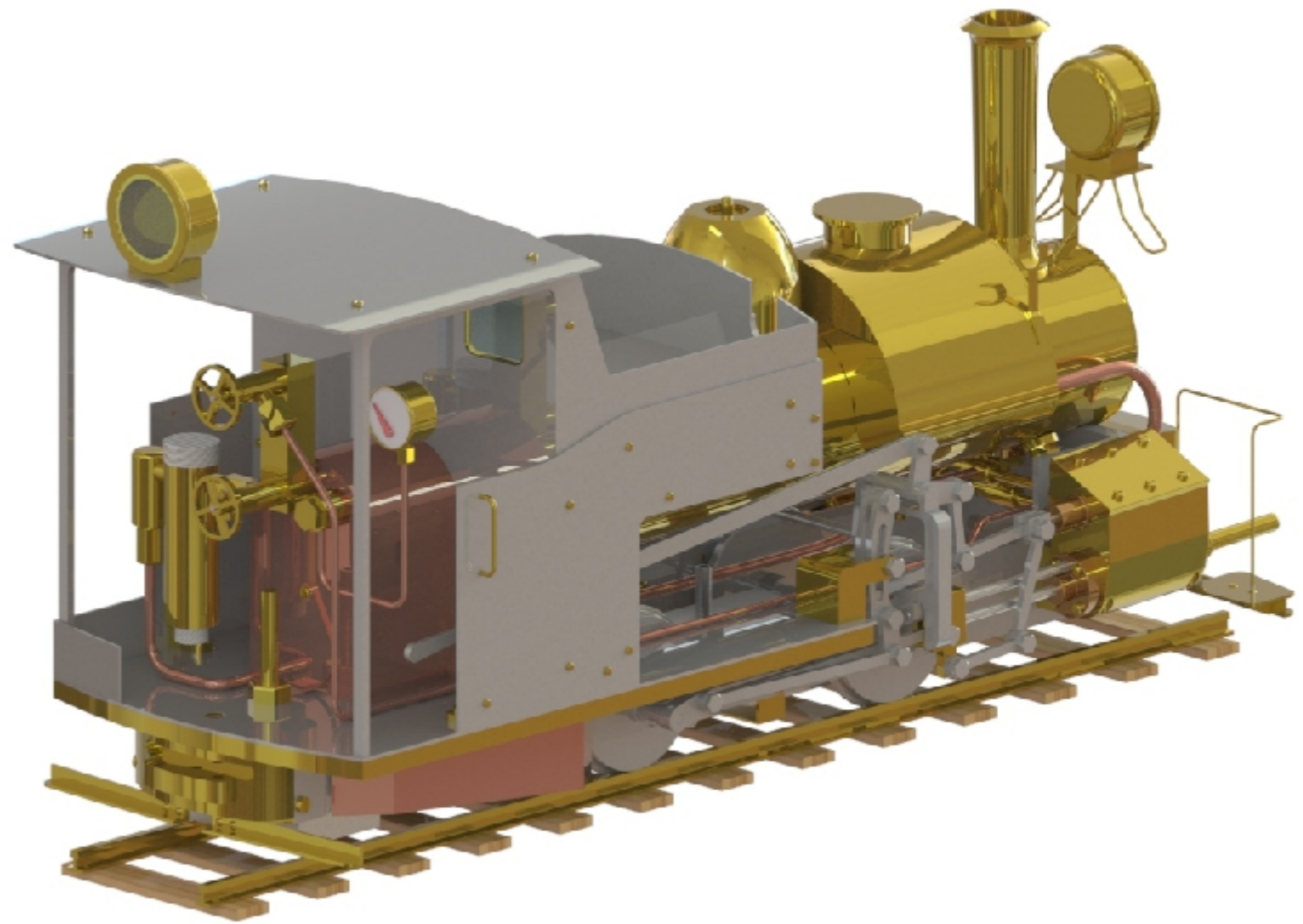
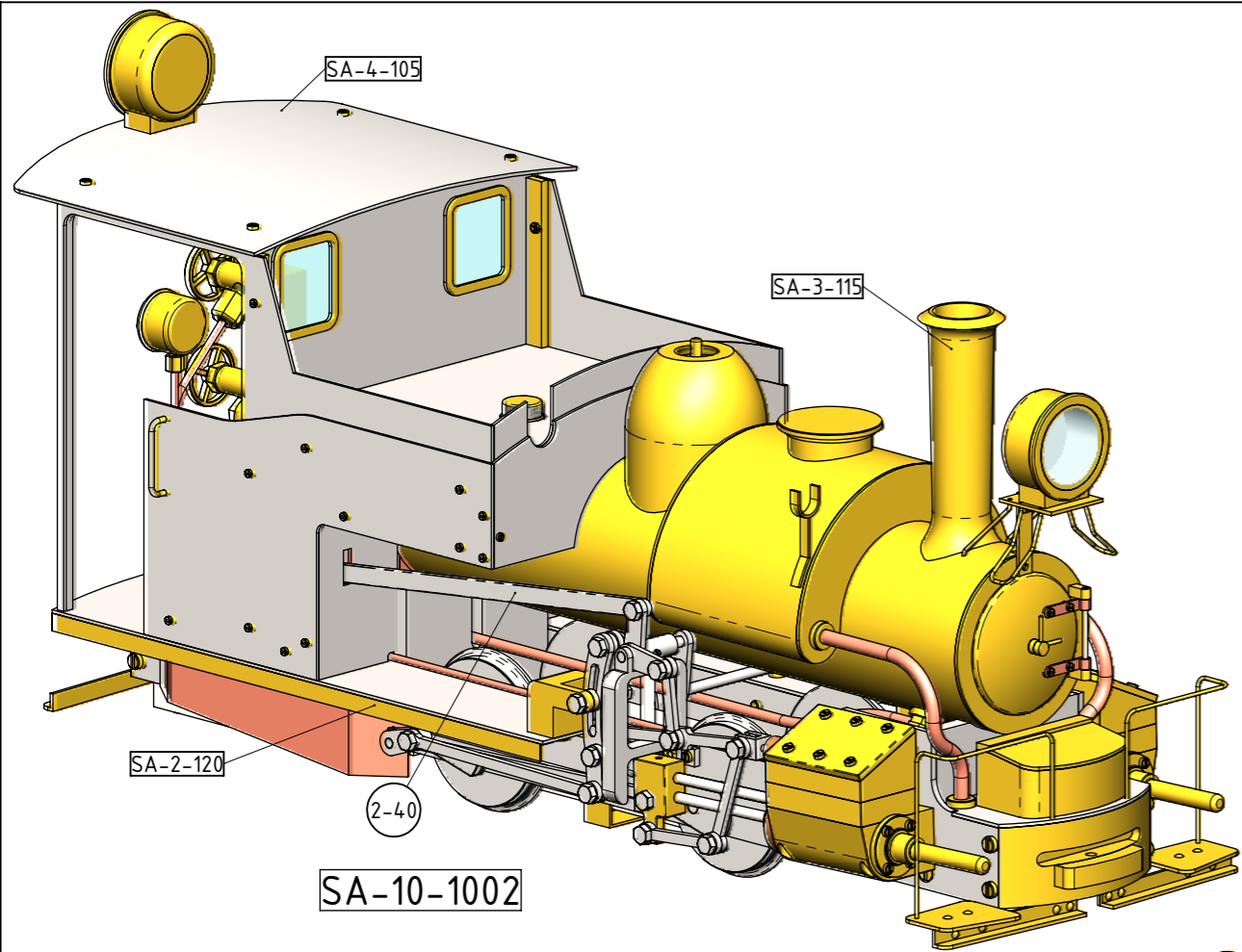

TITLE
 DARJEELING HIMALAYAN RAILWAY "B-CLASS"
 STEAM LOCOMOTIVE

DRAWING CONTENTS
 ASSEMBLIES

PROJECT No
 JDW DRAUGHTING SERVICES
 J.A.M. DE WAAL, 12 BRIGHTWELL STREET PAPAURA 2110,
 NEW ZEALAND. PHONE: 0064 09 2988815. MOB: 0211791000
 E-MAIL: dewaal@xtra.co.nz.

PROJECTION 	JDWDS	MODEL SCALE: 1:13.3 GAUGE 45mm
DATE DECEMBER 2014	Copyright © J.A.M. DE WAAL PAPAURA NZ	DWG SCALE: 1:1 @A3 OR AS SHOWN
SHEET: 09 OF 09	A3	No: DHR-B-45-09