

Motorcycle/ATV Division

GS/GSX/GSX-R No. 233

October 10, 2014

REVISED JUNE 5, 2015

SAFETY RECALL 2011-2014 GSX-R750 and 2009-2014 GSX-R1000 DRIVE CHAIN ADJUSTER

Affected Models: 2011-2014 GSX-R750/Z, 2009-2014 GSX-R1000/Z

Reference: 2011-2014 GSX-R750 Service Manual, P/N 99500-37150-03E
2009-2014 GSX-R1000 Service Manual, P/N 99500-39380-03E

Affected Departments: Management, Service, Warranty, Sales, Parts, Accessories

This notice is sent to you in accordance with the requirements of the National Traffic and Motor Vehicle Safety Act. Suzuki Motor Corporation has decided that a defect which relates to motor vehicle safety exists in 2011-2014 GSX-R750/Z, 2009-2014 GSX-R1000, and 2013-2014 GSX-R1000Z Suzuki motorcycles listed above.

STOP DELIVERY OF AFFECTED MOTORCYCLES IMMEDIATELY

DO NOT SELL OR DELIVER an affected motorcycle to a customer until you have completed, or verified completion of, the repair procedures outlined in this bulletin.

It is a violation of Federal law to sell or deliver any new vehicle subject to a safety recall campaign under a sale or lease until the defect or noncompliance has been corrected. You must verify this on the Suzuki "Certificate of Vehicle Pre-Delivery" form, which is to be completed for all new and used vehicle sales.

In addition to being a violation of Federal law, selling a non-repaired unit is a direct violation of your Suzuki dealer agreement and may lead to additional sanctions.

What is the problem?

If the motorcycle rider does not upshift the transmission correctly, a missed shift can occur, resulting in a neutral condition and high engine speed. If the rider tries to recover from the missed shift by upshifting without disengaging the clutch, a very large torque is applied to the drive sprocket. This will cause the upper part of the drive chain to immediately experience very high tension, which can result in the left-side of the rear axle shaft moving forward and damaging the left-side drive chain adjuster, which may result in the chain derailing from the sprocket. If the drive chain comes off the sprocket while the motorcycle is being operated, engine power will not be transmitted to the rear wheel. This may result in loss of control of the motorcycle, and can increase the risk of a crash.

<u>Affected Units:</u>	<u>Model</u>	<u>Model Year</u>	<u>VIN Range</u>
	GSX-R750	2011-2014	ALL
	GSX-R750Z	2014	ALL
	GSX-R1000	2009-2014	ALL
	GSX-R1000Z	2013-2014	ALL

Verify the chain adjusters require replacement:

Before performing the recall repair to a unit, first verify the repair needs to be performed by accessing the Vehicle Master Inquiry on Suzuki Connect and checking the repair status. If the repair needs to be performed, you will see the message “CAMPAIGN NOT YET PERFORMED.”

Also visually inspect the chain adjuster(s) to confirm replacement is required: The current chain adjuster has smooth, rounded edges; the replacement chain adjuster has edges that are more sharply angled.

What your dealership will do:

Install the replacement chain adjuster(s) and the replacement axle nut. Then submit a Warranty Claim for reimbursement.

What Suzuki Motor of America, Inc. will do:

During the week of October 13, 2014, Suzuki Motor of America, Inc. will mail notification letters to owners of affected motorcycles for whom we have information. The letter instructs the customer to contact a Suzuki dealer to schedule an appointment. All units invoiced to your dealership after October 6, 2014, will already have the recall service performed.

If you have sold an affected unit and have not registered the sale of that unit, do so immediately so a Safety Recall Notice can be mailed to the customer.

Ordering parts for the Recall Campaign:

- Parts for this campaign will be available the week of October 6, 2014.
- Use the normal parts ordering procedure to order the parts kit(s) needed for units in your inventory or for customer units in your shop for service.
- **If you order Limited Edition P/N 61400-44830-RX0 or P/N 61400-44840-RX0 listed below, you MUST also call Suzuki Parts Coordination at (714) 854-2165 to confirm the VIN and to release the part.**
See Parts & Accessories Bulletin No. 14-04 for more information.
- If you have questions any other questions regarding your parts order, please contact National Parts Coordination at (714) 854-2165.



PARTS ORDERING INFORMATION					
Model	Model Year	Kit Type	Kit Part Number	Qty. Required	Dealer net
GSX-R750	2011-2014	Chain Adjuster Set	61400-44810-RX0	1	\$28.36
GSX-R750Z	2014	*Chain Adjuster Set	61400-44830-RX0	1	\$28.36
GSX-R1000	2009-2014	Chain Adjuster Set	61400-44820-RX0	1	\$38.03
GSX-R1000Z	2013				
GSX-R1000Z	2014	*Chain Adjuster Set	61400-44840-RX0	1	\$60.03

* You MUST call Suzuki Parts Coordination at (714) 854-2165 to confirm the VIN and to release the part.



Warranty Claim Processing:

Submit a warranty claim for each recall campaign service immediately upon completion of the repair. This campaign requires you to file a warranty claim using ONE of the methods described below:

Suzuki Connect Short Campaign Claim:

A Short Campaign Claim will reimburse you for replacement of the chain adjuster(s), the axle nut, and the applicable labor.

RECALL CAMPAIGN — GSX-R DRIVE CHAIN ADJUSTER REPLACEMENT SUZUKI CONNECT SHORT FORM INSTRUCTIONS	
CLAIM NUMBER:	XXXXX.X (Dealer enters number)
ENTRY TYPE (Dealer chooses):	VIN, Model/Frame, or Control
REPAIR DATE:	Enter date of repair
MILEAGE:	Enter mileage at repair date
CAMPAIGN NUMBER:	See Fig. 1 on next page

Suzuki Connect Long Campaign Claim:

The Long Campaign Claim entry should be used when additional parts or labor are required to complete the Recall Campaign service. A Long Form Claim will require TSM authorization.

RECALL CAMPAIGN — GSX-R DRIVE CHAIN ADJUSTER REPLACEMENT SUZUKI CONNECT LONG FORM INSTRUCTIONS	
CLAIM INFORMATION	
CLAIM NUMBER:	XXXXX.X (Dealer enters number)
ENTRY TYPE (Dealer chooses):	VIN, Model/Frame, or Control
REPAIR DATE:	Enter date of repair
MILEAGE:	Enter mileage at repair date
CAMPAIGN NUMBER:	See Fig. 1 on next page
LABOR HOURS:	AS AUTHORIZED
LABOR OPERATION:	HM9999
PARTS INFORMATION	
REPLACEMENT PARTS:	AS AUTHORIZED
FAILURE DESCRIPTION	
DESCRIPTION OF DEFECT:	GSX-R Drive Chain Adjuster
DESCRIPTION OF REPAIR:	Performed recall repair as required per Service Bulletin
SUBLET INFORMATION	
SUBLET AMOUNT:	AS AUTHORIZED
INVOICE NUMBER:	Use campaign number
SUBLET REPAIR DESCRIPTION:	AS AUTHORIZED

WARRANTY INFORMATION

Model	Model Year	Kit Type	Kit Part Number	Flat Rate (HR)	Campaign Number
GSX-R750	2011-2014	Chain Adjuster Set	61400-44810-RX0	0.3 HR	2A40
GSX-R750Z	2014	Chain Adjuster Set	61400-44830-RX0	0.3 HR	2A41
GSX-R1000	2009-2014	Chain Adjuster Set	61400-44820-RX0	0.3 HR	2A42
GSX-R1000Z	2013				
GSX-R1000Z	2014	Chain Adjuster Set	61400-44840-RX0	0.4 HR	2A43

Installation Procedure: 2011-2014 GSX-R750/Z, 2011-2014 GSX-R1000, 2013 GSX-R1000Z

- 1) Place the motorcycle on the side-stand.
- 2) Remove the axle nut (1), washer (2) and left-hand chain adjuster (3).

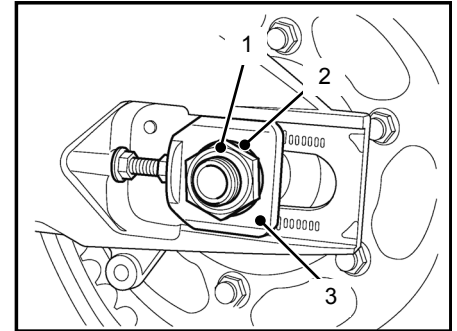

- 3) Install the new left-hand chain adjuster (4) and the original washer (2).
- 4) Temporarily tighten the new axle nut (6).

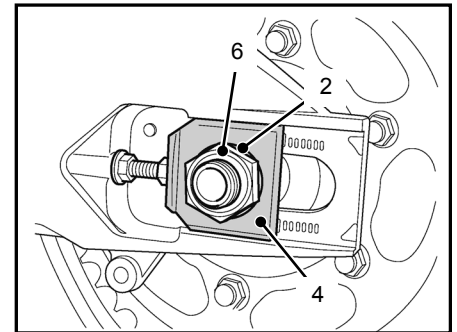

- 5) Check the drive chain slack at the middle of the chain between the engine and rear sprockets. If the measurement is out of specification, adjust the drive chain slack.

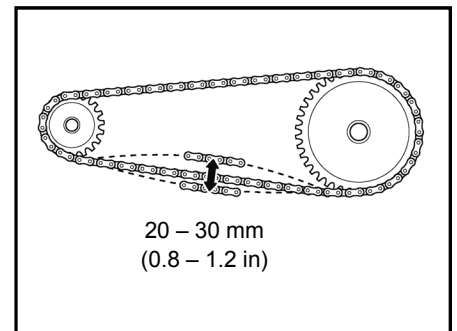

Drive chain slack

Standard: 20 – 30 mm (0.8 – 1.2 in)

NOTE:

The reference marks (A) on both sides of the swingarm and the edge of the chain adjusters must be aligned to ensure that the front and rear wheels are correctly aligned.

- 6) Tighten the axle nut (6) to the specified torque.

Tightening torque

Rear axle nut: 100 N•m (10.0 kgf-m, 72.5 lbf-ft)

- 7) Recheck the drive chain slack after tightening the axle nut (6).

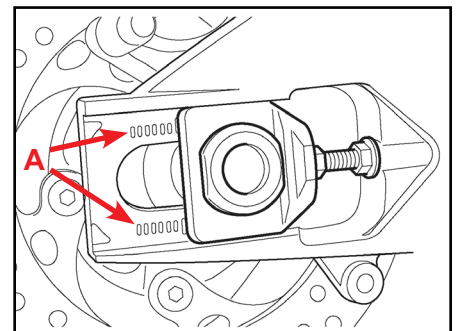

Installation Procedure: 2014 GSX-R1000Z

- 1) Place the motorcycle on the side-stand.
- 2) Loosen the axle nut (1).
- 3) Raise the rear wheel off the ground and support the motorcycle with a jack.
- 4) Remove the axle nut (1), washer (2) and left-hand chain adjuster (3).
- 5) Remove the axle (4).
- 6) Remove the right-hand chain adjuster (5).

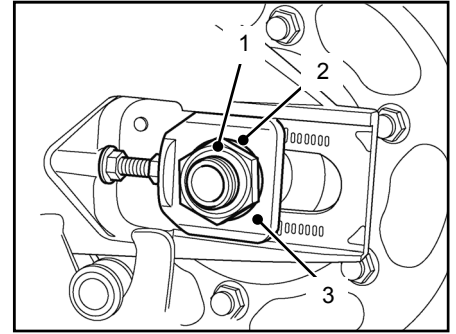

- 7) Install the new right-hand chain adjuster (6), axle (4), the new left-hand chain adjuster (7) and the original washer (2).
- 8) Temporarily tighten the new axle nut (8).
- 9) Remove the jack.

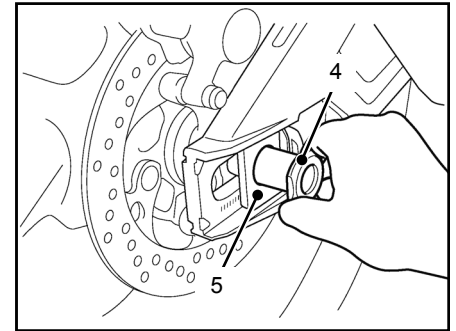

- 10) Check the drive chain slack at the middle of the chain between the engine and rear sprockets. If the measurement is out of the standard, adjust the drive chain slack.

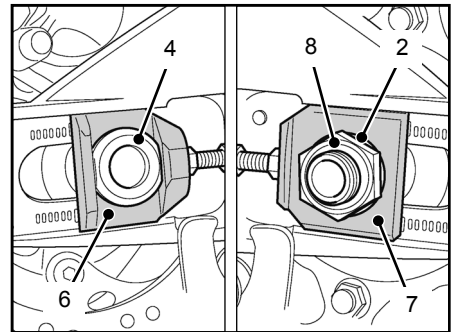

Drive chain slack

Standard: 20 – 30 mm (0.8 – 1.2 in)

NOTE:

The reference marks (A) on both sides of the swingarm and the edge of the chain adjusters must be aligned to ensure that the front and rear wheels are correctly aligned.

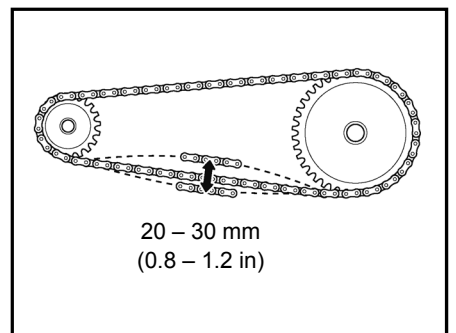

- 11) Tighten the axle nut (8) to the specified torque.

Tightening torque

Rear axle nut: 100 N•m (10.0 kgf-m, 72.5 lbf-ft)

- 12) Recheck the drive chain slack after tightening the axle nut (8).

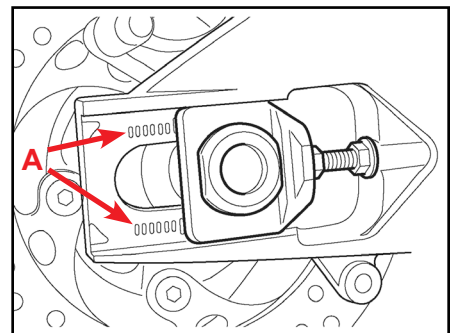



SUZUKI MOTOR OF AMERICA, INC.

IMPORTANT SAFETY RECALL

This Notice Applies to Your Motorcycle VIN: xxxxxxxxxxxxxxxxx

October 17, 2014

Dear Suzuki Owner:

This notice is sent to you in accordance with the National Traffic and Motor Vehicle Safety Act. Suzuki Motor Corporation has decided that a defect which relates to motor vehicle safety exists in 2011-2014 GSX-R750/Z, 2009-2014 GSX-R1000, and 2013-2014 GSX-R1000Z Suzuki motorcycles.

What is the problem?

If the motorcycle rider does not upshift the transmission correctly, a missed shift can occur, resulting in a neutral condition and associated high engine speed. If the rider tries to recover from the missed shift by upshifting without disengaging the clutch, a very large torque is applied to the drive sprocket. This will cause the upper part of the drive chain to immediately experience very high tension, which can result in the left-side of the rear axle shaft moving forward and damaging the left-side drive chain adjuster, which may result in the chain derailing from the sprocket. If the drive chain comes off the sprocket while the motorcycle is being operated, engine power will not be transmitted to the rear wheel. This may result in loss of control of the motorcycle, and can increase the risk of a crash.

For your safety and customer satisfaction, we are initiating a safety recall campaign to replace the drive chain adjuster(s).

WARNING

Operating your motorcycle without having the recall service performed may increase the risk of a crash.

To minimize the risk of a crash, do not ride or allow anyone else to ride your motorcycle until this recall service has been completed.

What is Suzuki Motor of America, Inc. doing to solve the problem?

Your dealer will replace the drive chain adjuster(s) and the axle nut. This procedure will take approximately 30 minutes to complete. Parts are available now, and there will be no charge to you for any recall service-related parts or labor.

What you should do:

Make sure you are prepared for the recall service by taking the following steps:

- **Before** taking your motorcycle to your dealer, contact them as soon as possible to set up an appointment for the recall service.
- We suggest that you bring this letter and the enclosed card to your dealer to help your dealer process your claim.
- If you have additional questions, please visit <http://www.suzukicycles.com/recalls.aspx> to read the *2011-2014 GSX-R750 and 2009-2014 GSX-R1000 Drive Chain Adjuster Frequently Asked Questions*.

What to do if you receive this letter in error:

This notice was mailed to you according to the most current information we have available. If you no longer own the Suzuki motorcycle described in this letter, please complete and return the enclosed postage-paid card to Suzuki Motor of America, Inc., and forward this recall information to the current owner (if known).

Federal regulations require that any vehicle lessor receiving this recall notice must forward a copy of this notice to the lessee within ten days.

Customer reimbursement for prior drive chain adjuster replacement:

If your motorcycle is included in the recall and you have paid for replacement of the drive chain adjuster(s) or other repairs to address the defect that led to this recall, you may be eligible for full or partial reimbursement. **To request reimbursement for a previous repair, contact your Suzuki dealer.**

Please note the following conditions for reimbursement:

- Only repairs made to address the defect that led to this recall are reimbursable. Additional expenses such as towing, car rental, accommodations, damage repairs, etc., will not be reimbursed. Reimbursement will not be provided for routine scheduled maintenance.
- Reimbursement may be limited to the suggested list price for parts, the Suzuki published flat rate time allowance for the repair, and the labor rate that an authorized Suzuki dealer in the same area would charge for the same repair.
- An owner will not be eligible for reimbursement if the expenses for repairs are incurred more than 10 days after the date of the last owner notification letter sent by Suzuki Motor of America, Inc.
- Reimbursement claims may also be excluded when adequate documentation is not submitted by the claimant. This includes a proof of ownership, a repair order, and proof of payment for the repair.

Who to contact if you experience problems:

Your Suzuki dealer can provide you the fastest response to your questions or concerns about the drive chain adjuster replacement campaign. If you have any difficulty with this recall campaign, you may contact the Suzuki Motor of America Customer Service Department for assistance using the direct Customer Service telephone line at (714) 572-1490 during the hours of 8:30 AM to 4:30 PM Pacific Time. Please have your Vehicle Identification Number (VIN) ready when calling. You may also leave a brief message at (800) 444-5077 and a representative from the Suzuki Motor of America Customer Service Department will contact you.

If you believe that Suzuki Motor of America has failed to provide the Recall service without charge or is unable to do so within a reasonable time, you may submit a complaint to the Administrator of the National Highway Traffic Safety Administration, 1200 New Jersey Ave., S.E., Washington D.C., 20590 or call the toll-free Vehicle Safety Hotline at 1-888-327-4236 (TTY: 1-888-424-9153) or go to: www.safercar.gov

We apologize for any inconvenience this recall campaign causes you. We hope you understand that your safety, satisfaction and riding pleasure are important priorities for Suzuki.

Sincerely,

Suzuki Motor of America, Inc.