

Un des problèmes des trains de jardin en voie de 45mm demeure la qualité et la continuité de l'alimentation électrique. L'utilisation de machines propulsées à la vapeur ou par batterie met un terme au problème. Les autorails avec ou sans remorque pourraient être de bons candidats grâce la place qu'ils laissent pour les batteries.

Julius de Waal nous propose deux railcars d'origine irlandaise tout à fait mignons. Mais auparavant un peu de documentation

Les Railcar

Si en Angleterre le terme railcar recouvre la même notion que chez nous les autorails, aux USA l'acceptation est bien plus large. Le railcar va de la draisine bricolée pour l'inspection des voies et leur petit entretien jusqu'à de vrais autorails.

Je n'ai pu résister au plaisir de mettre quelques photos d'origine US glanées sur Internet car dans ce domaine l'imagination est au pouvoir, ce qui fait bien l'affaire des modélistes.





<http://www.backwoodsminiatures.com/0n3kits.htm>





Mc Keen Railcar

The Galloping goose

« L'oie coureuse » tient une place à part dans les railcars aux USA. Ce nom fait référence à 7 railcars construits entre 1931 et 1936 par la Rio Grande Southern Railroad (RGS) à partir d'éléments disponibles de l'industrie automobile et ferroviaire. RGS exploitait environ 200 km de voie en 3' (914mm) allant de Durango à Ridgway dans l'état du Colorado. Le faible trafic de cette région désertique et la concurrence naissante du fret routier avaient amené RGS, vers la fin des années 1920, au bord de la faillite compte tenu du coût d'exploitation des machines à vapeur. Le remplacement des machines à vapeur par des Galloping goose a permis à RGS de se maintenir jusqu'au début des années 1950 où RGS a cessé d'exploiter le réseau. Aujourd'hui une partie du réseau est exploité comme chemin de fer touristique.

Les galloping goose étaient bien entendu beaucoup moins chères à l'usage que les machines à vapeur, mais surtout bien plus légères et n'abîmaient pratiquement les voies.

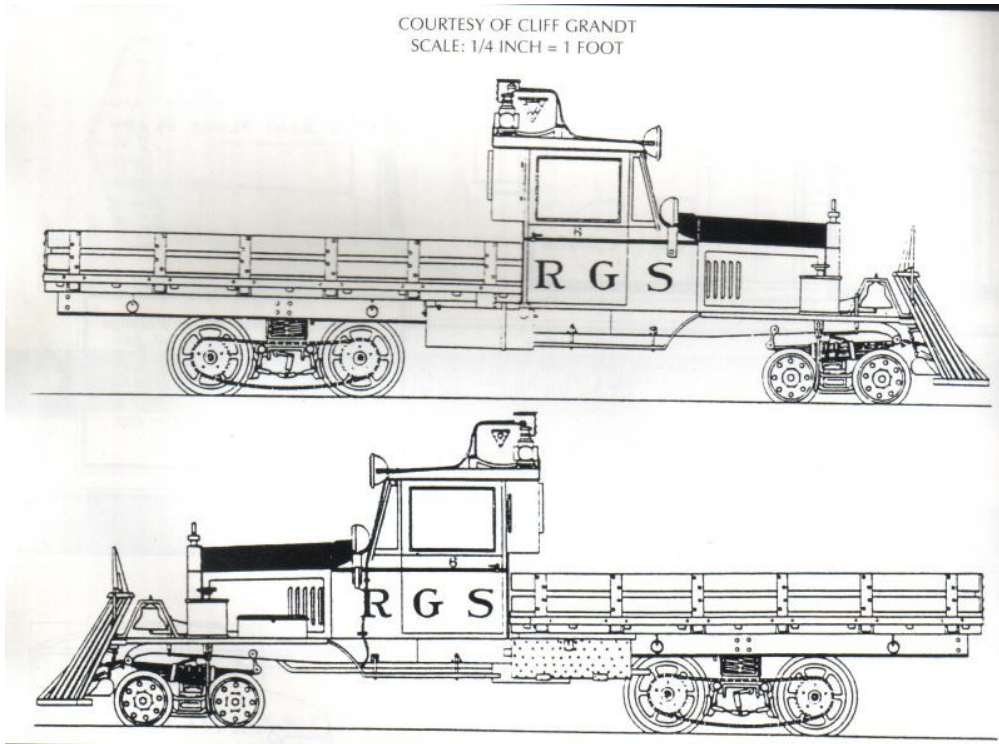
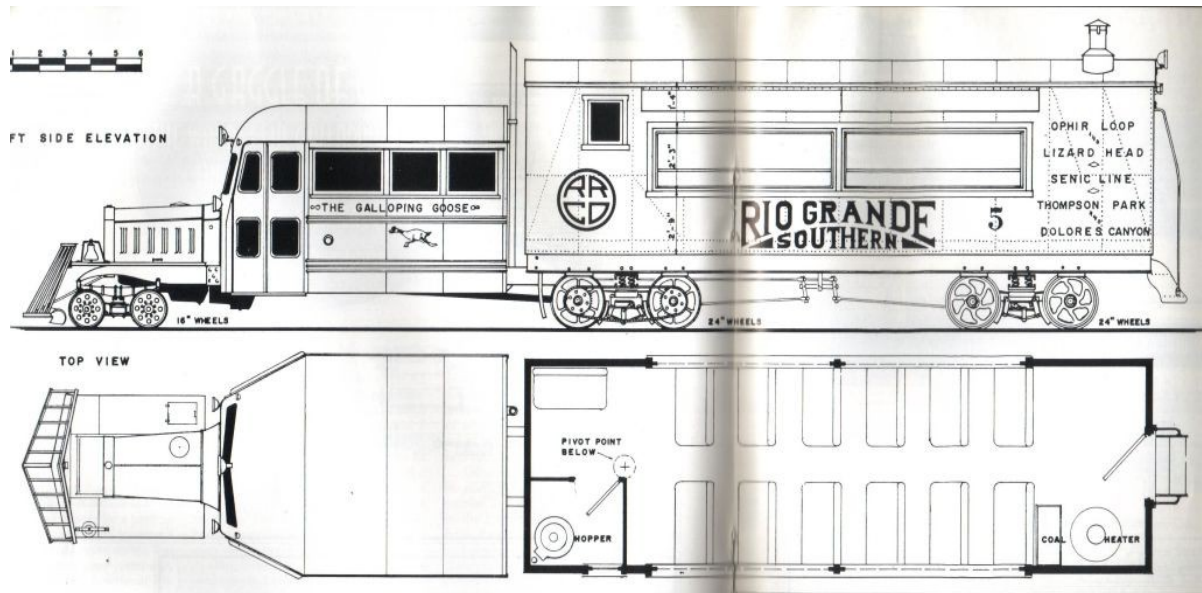



Les autorails De Dion

Sources : Internet

Plus familiers et plus proches de nous, j'avoue avoir un faible pour l'eshétique de l'autorail ancien De Dion Bouton

En voici un bel exemple restauré par le MTVS



<http://www.musee-mtvs.com/autorail-de-dion-bouton-ex-cotes-du-nord/>

Il a été acquis par l'AMTUIR et stocké au MTVS pour sa remise en état.

Autorail de Dion Bouton JM4 n°. 11

Constructeur : De Dion-Bouton

Année de construction : 1932

Poids : 6,5 tonnes Puissance : 60 chevaux à essence

Il a été construit par Carel et Fouché pour la caisse de l'autorail et par de Dion-Bouton pour le châssis motorisé.

Il a fonctionné jusqu'en 1956, date de la fermeture du réseau des Côtes du Nord, et a servi au démontage de la voie en compagnie de la n°. 36, dite Lulu.

Il a une vitesse en marche arrière et trois en marche avant. Au bout de la ligne il peut être retourné grâce à un vérin mécanique, et être orienté dans le sens de marche.

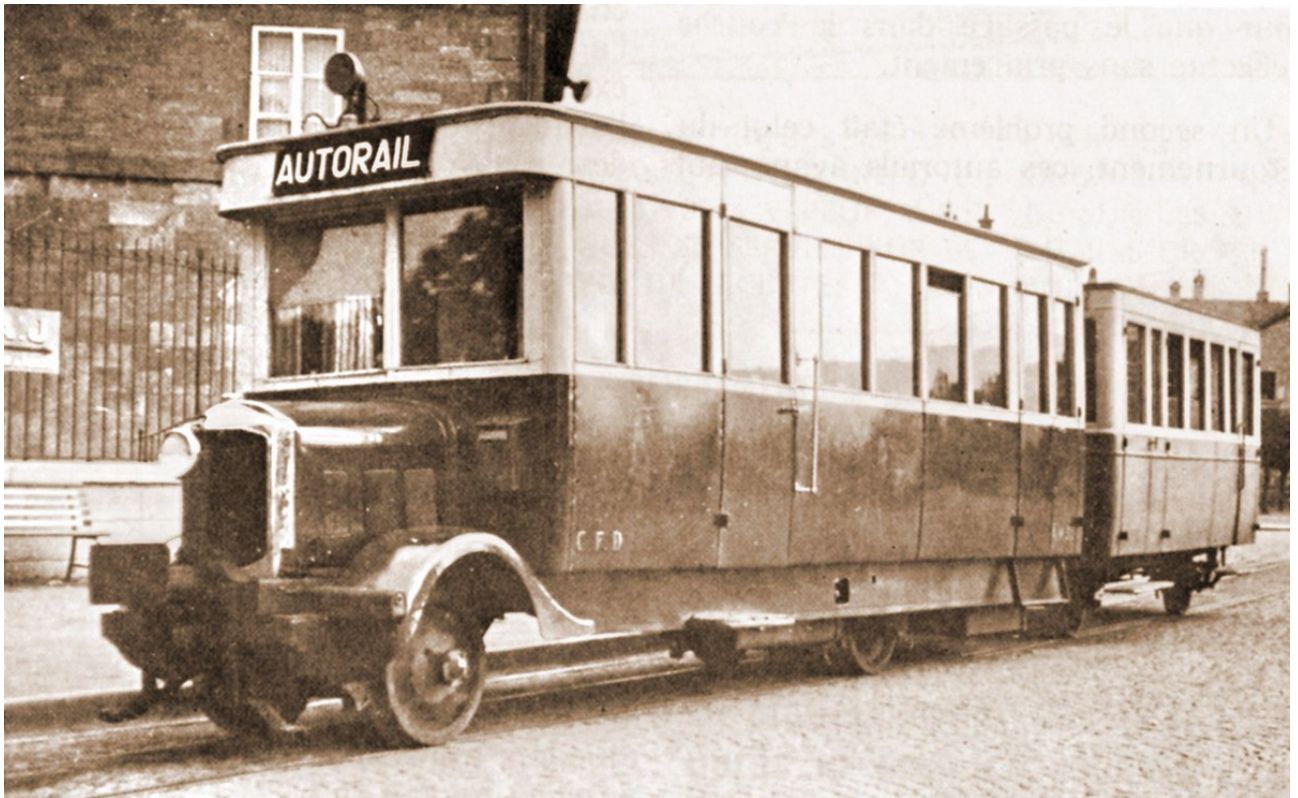
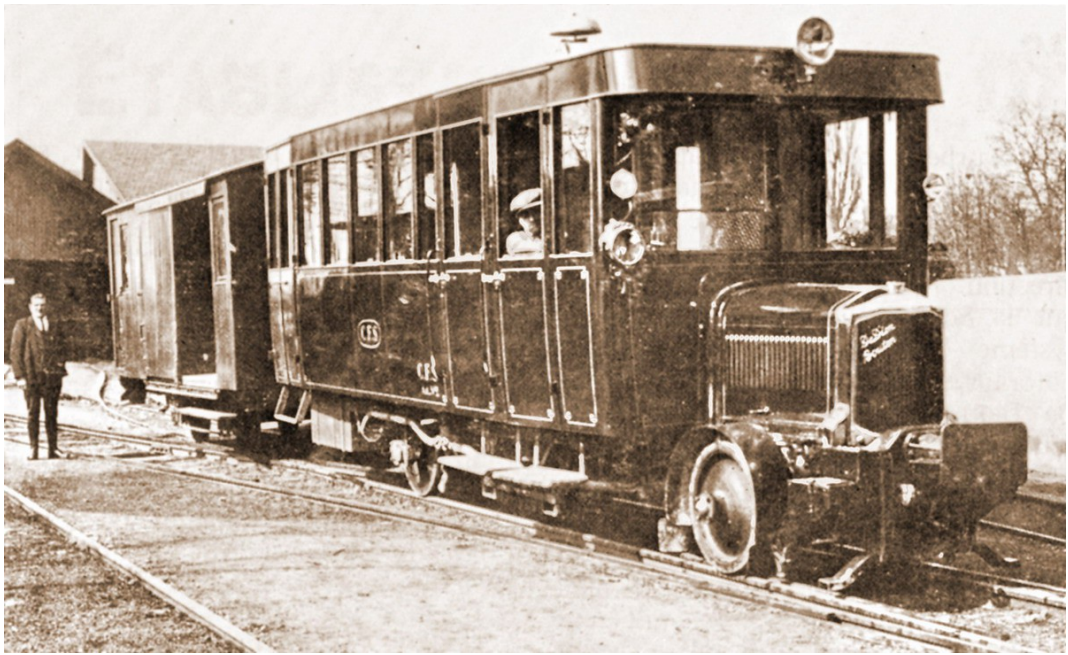

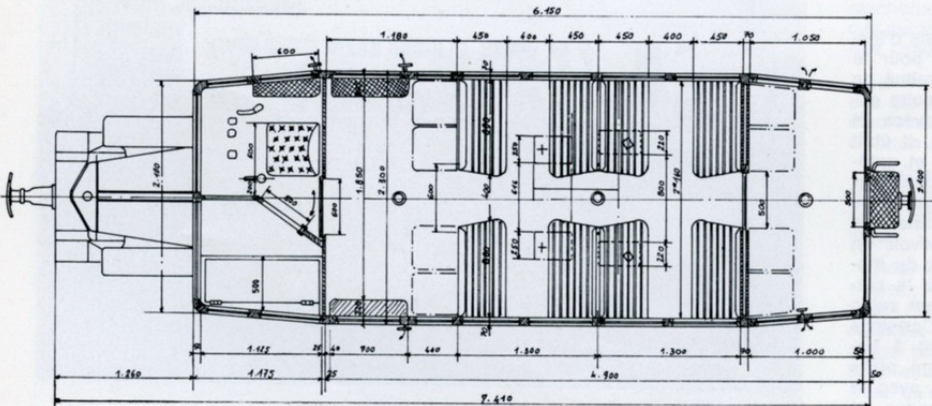
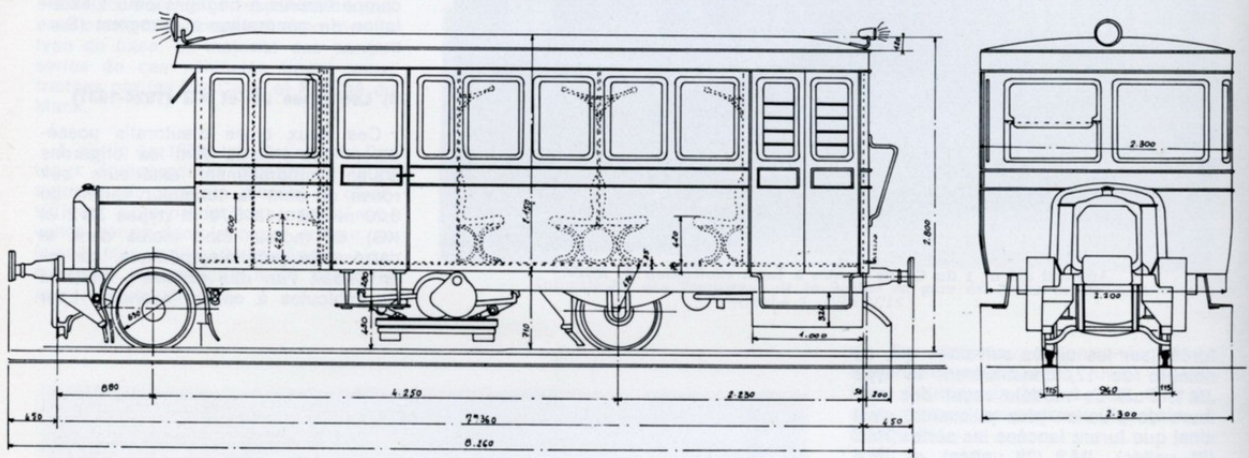
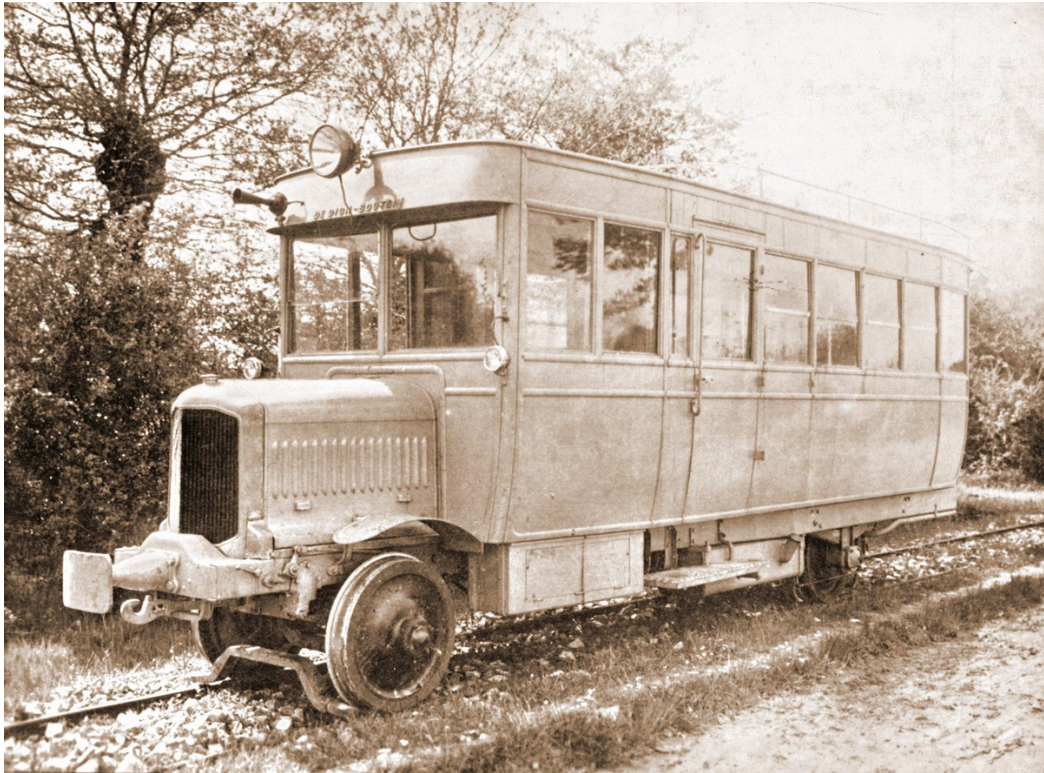

Plan de l'autorail type JM au 1/60^e. (Dessin J.-P. SOUDET.)

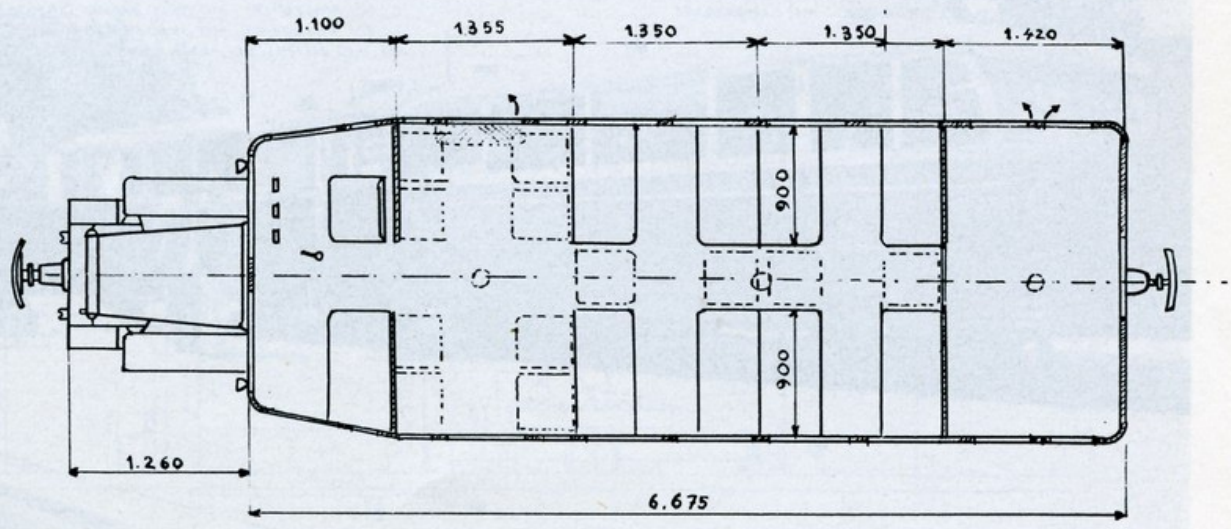
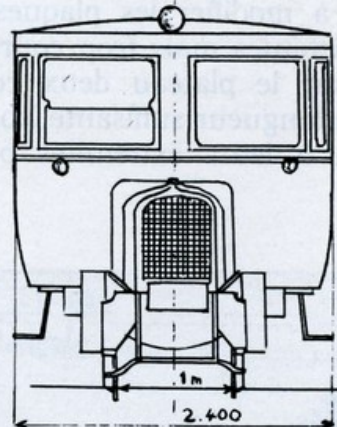
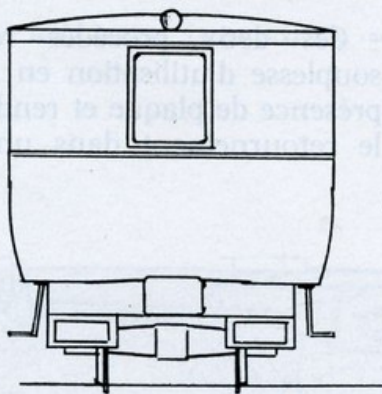
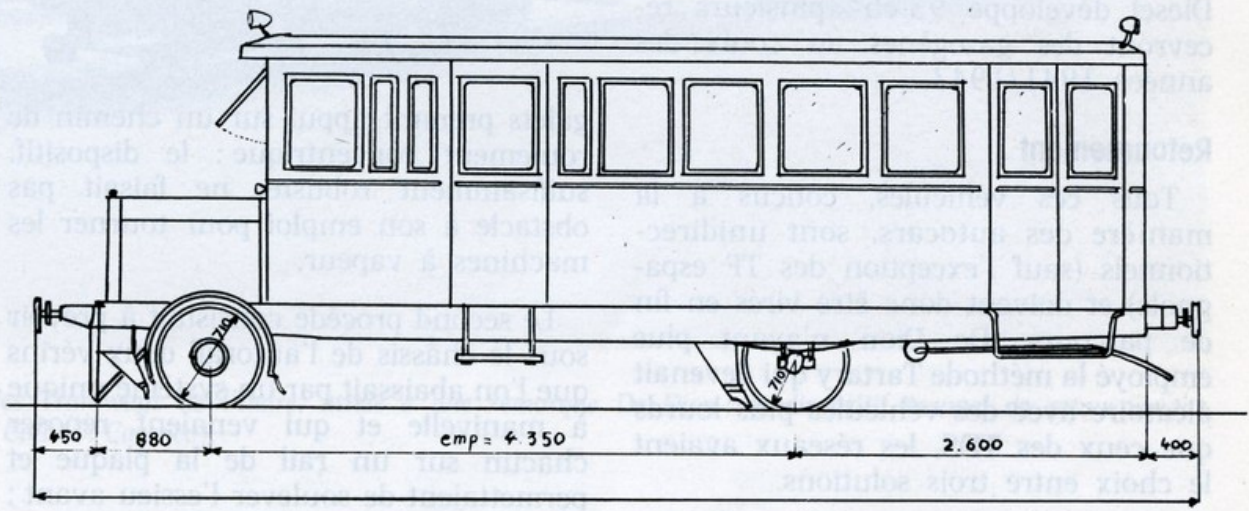

D.D.B. type JM4

Diagramme des autorails du type JM 4 (Doc. P. Carencio).

Une des meilleures sources d'information.



County Donegal Railways (CDR)

<http://www.donegalrailway.com/>

<http://www.donegalrailway.com/resources-models/>

<http://spellerweb.net/rhindex/Ireland/Donegal.html>



Le réseau du comté de Donegal a fonctionné de 1906 à 1960 en voie étroite de 3' (914mm).

L'origine du réseau vient de la fusion en 1892 :

- du réseau de 23 km Finn Valley Railway en 5'3" (1600mm) allant de Strabane à Stranorlar, ouvert en 1863.
- du réseau de 29km West Donegal Railway 3' (914mm) allant Stranorlar à Donegal, ouvert 1889.

Les deux réseaux ont été unifiés en voies de 3'. En 1906 l'ensemble avec les embranchements totalisait 170 km de voies.

En 1906 cette ligne privée fut conjointement acquise par Northern Counties Committee of the Midland Railway (England) et Great Northern Railway (Ireland).

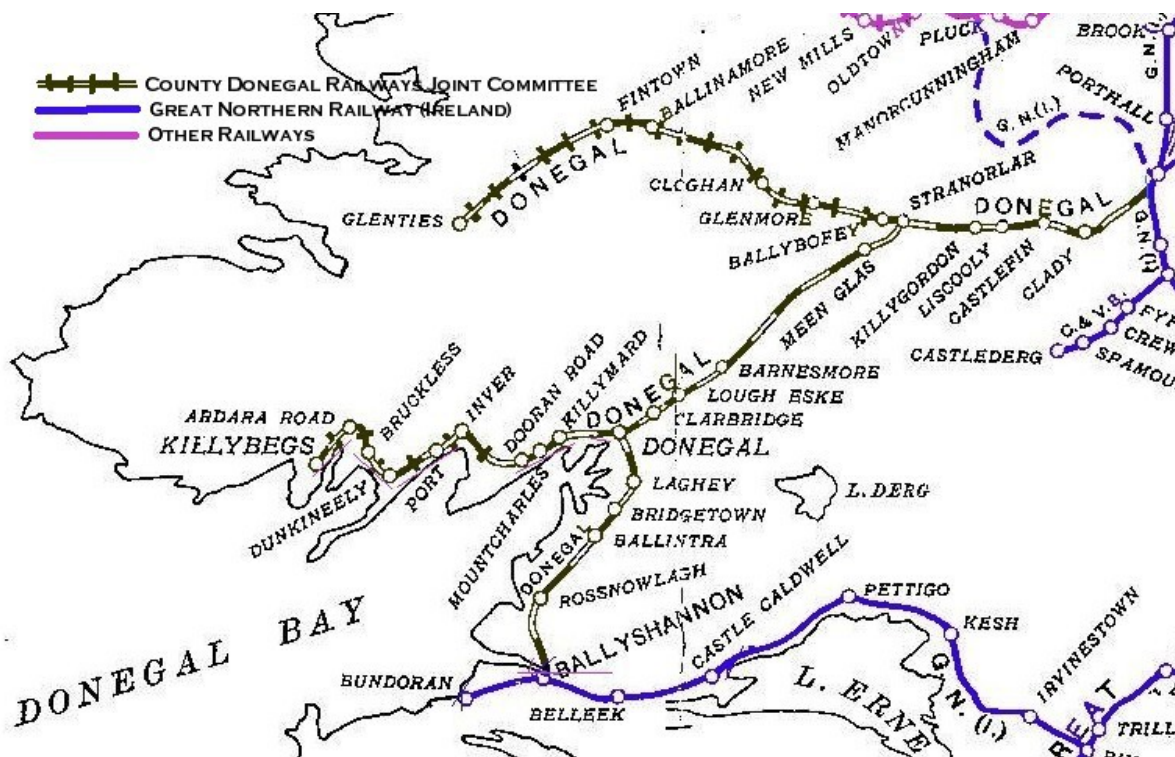

Ce petit réseau a été un des pionniers des railcars à traction diesel. Ils ont été les premiers, dans les îles britanniques, à mettre en exploitation un railcar diesel en 1930. La standardisation est intervenue vers 1934. Huit machines furent construites entre 1934 et 1951 par Walker Brothers of Wigan assurant pratiquement la totalité du service passager. Ces railcars étaient capable de tracter de petits convois de remorques de fret. Le réseau arrêta l'exploitation en 1959.

En plus de cette flotte Diesel, CDR avait racheté en 1924 à Derwent Valley Light Railway deux railcars à essence basé sur un châssis « Ford 1 Ton truck » motorisé à 22CV. Ils disposaient de 17 places et furent retirés en 1934 après avoir donné toute satisfaction.



Railbus Ford Iton

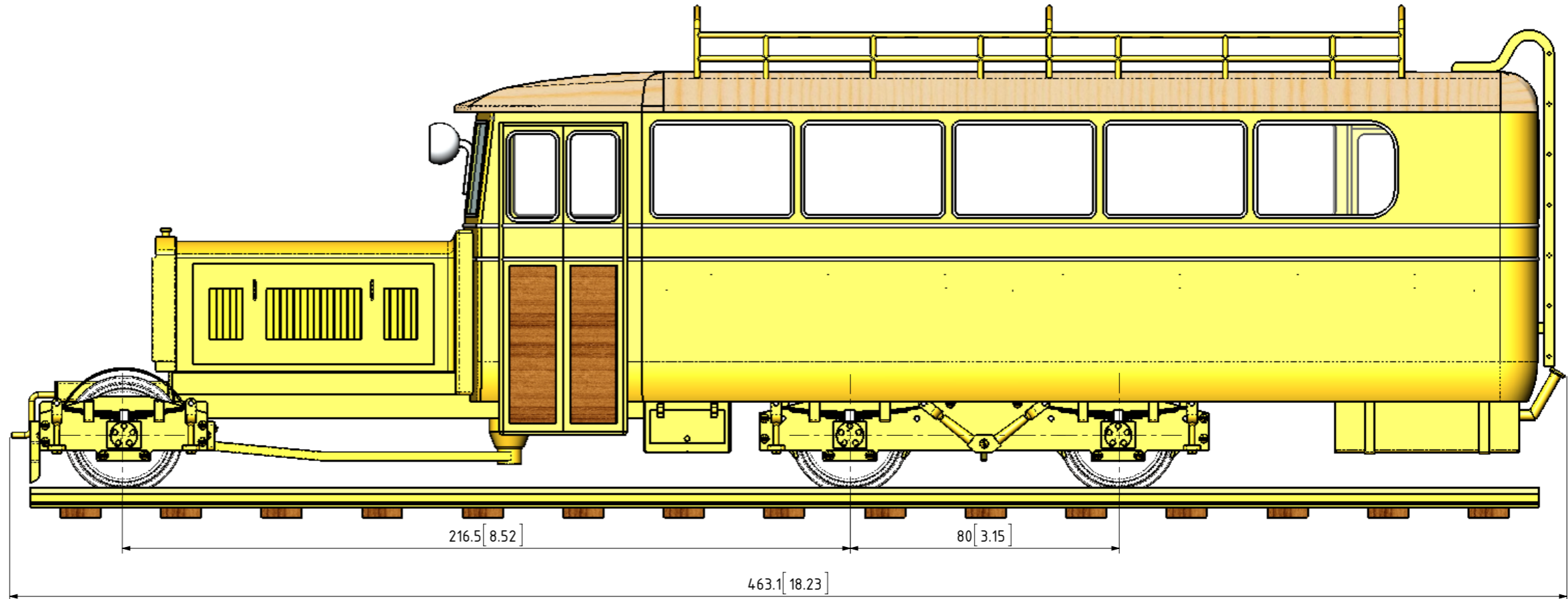
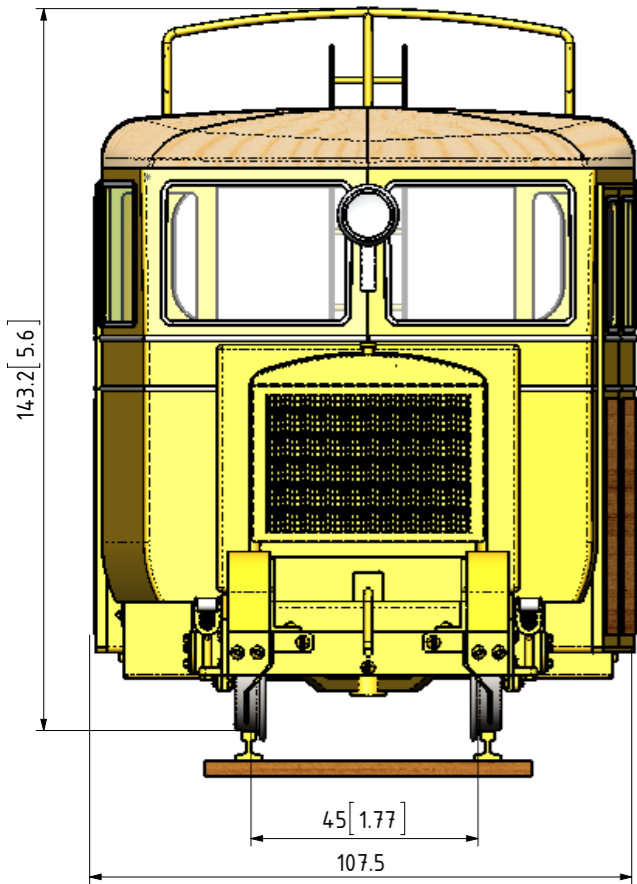
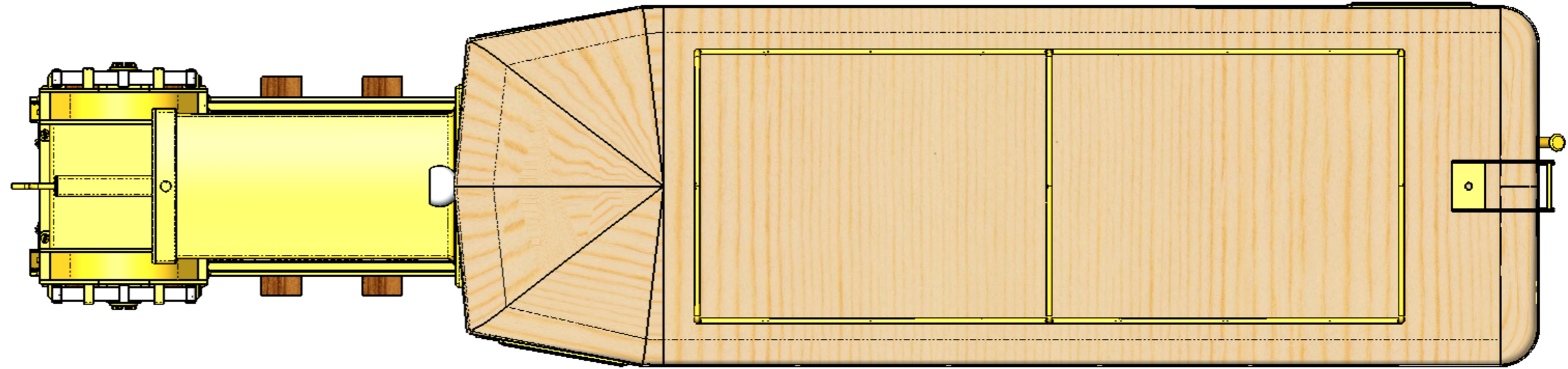
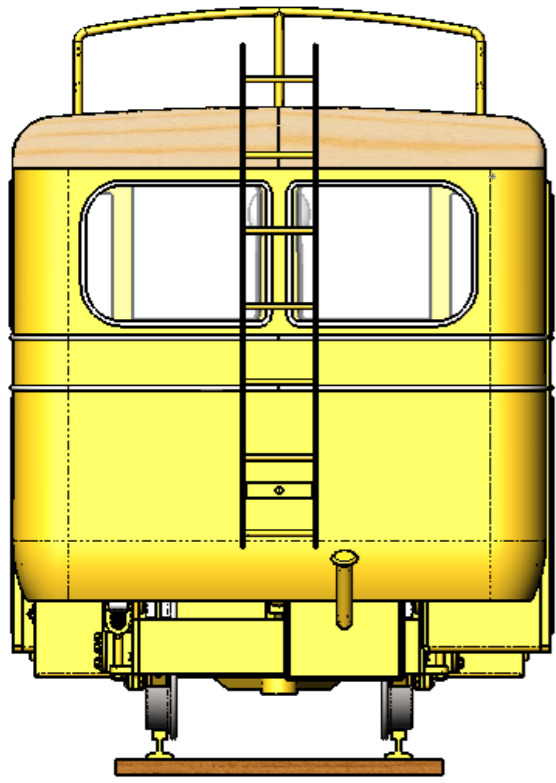

NOTES:

TITLE
 IRISH RAILCAR No7 OF THE COUNTY DONEGAL
 RAILWAY JOINT COMMITTEE

DRAWING CONTENTS
 GENERAL ARRANGEMENT

PROJECT No
 JDW DRAUGHTING SERVICES
 J.A.M. DE WAAL, 12 BRIGHTWELL STREET PAPAURA 2110,
 NEW ZEALAND. PHONE: 0064 09 2988815. MOB: 0211791000
 E-MAIL: dewaal@xtra.co.nz.

PROJECTION

 DATE DECEMBER-2010
 SHEET:01 OF 08

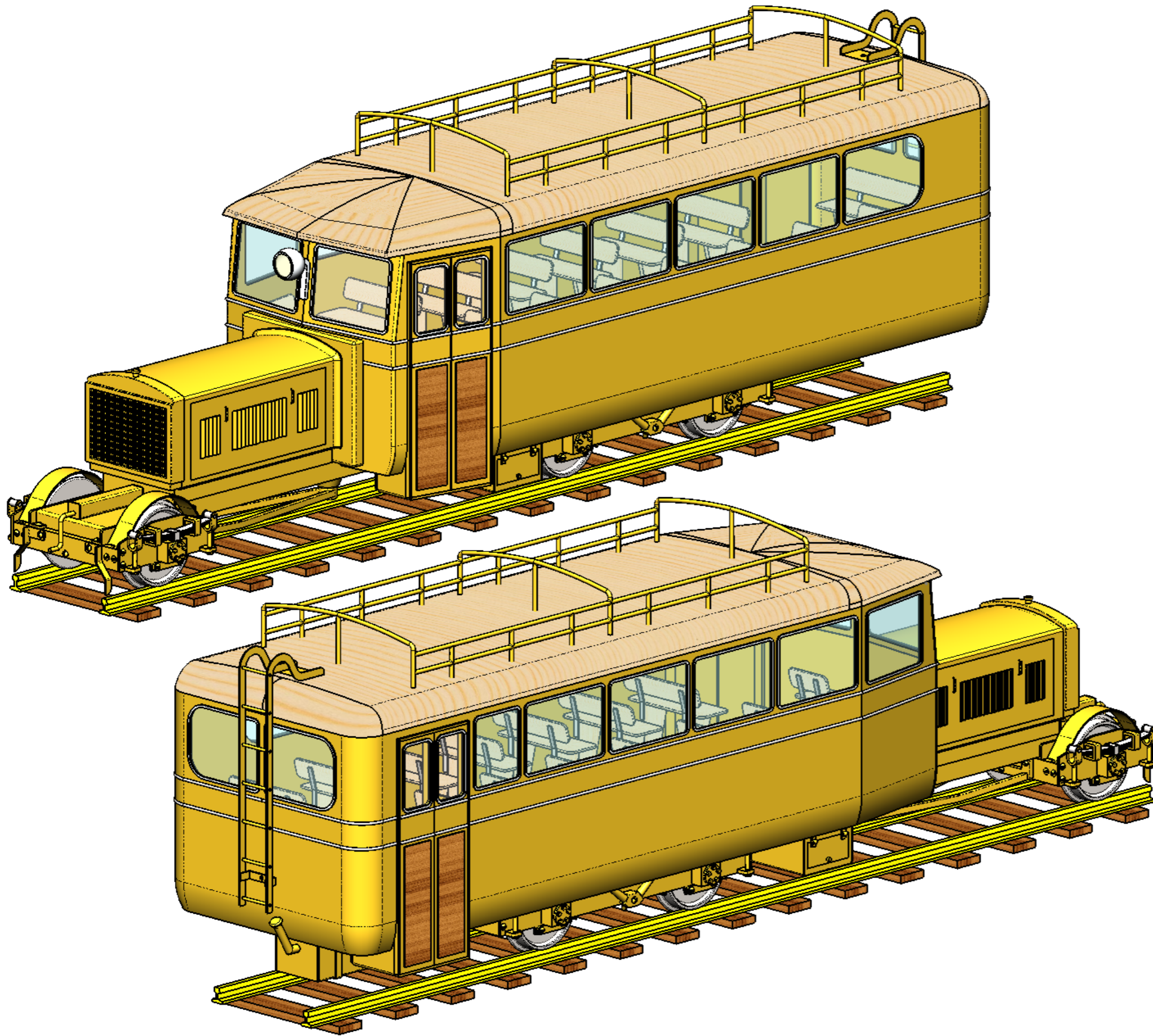
MODEL SCALE: 1:20.3 (GAUGE 1:4.5mm)
 DWG SCALE: 2:1 @A3 OR AS SHOWN
 Copyright © J. DE WAAL PAPAURA NZ
 A3 CDRJC7-45-01



QTY.	PART NUMBER
5	CDRJ7-45-1-01-UF-FLOOR BEAM 5x5x0.5x92
1	CDRJ7-45-1-01-UF-FLOOR BEAM 5x5x0.5x92
1	CDRJ7-45-1-02-UF-FLOOR BEAM 5x5x0.5x265
9	CDRJ7-45-1-03-UF-FLOOR BEAM 5x5x0.5x47
2	CDRJ7-45-1-04-UF-FLOOR BEAM 5x5x0.5x43
1	CDRJ7-45-1-05-UF-FLOOR BEAM 5x5x0.5x215
1	CDRJ7-45-1-06-UF-FLOOR BEAM 5x5x0.5x12
1	CDRJ7-45-1-07-UF-FLOOR BEAM 5x5x0.5x38
2	CDRJ7-45-1-10-UF-FLOOR BEAM 7x5x0.5x22
2	CDRJ7-45-1-11-UF-FLOOR BEAM 7x5x0.5x140
1	CDRJ7-45-1-13-UF-FLOOR BEAM 12x5x0.5x22
1	CDRJ7-45-1-14-UF-BOGIE MOUNTING PLATE
1	CDRJ7-45-1-15-UF-REAR EXIT STEPS
1	CDRJ7-45-1-16-UF-FRONT ENTRY STEPS
1	CDRJ7-45-1-17-UF-LUGGAGE COMPARTMENT
2	CDRJ7-45-1-18-UF-LUGGAGE COMPARTMENT DOOR
1	CDRJ7-45-1-19-UF-FUEL TANK
1	CDRJ7-45-1-20-UF-FUEL TANK FILLER
2	CDRJ7-45-1-21-UF-FUEL TANK STRAP
1	CDRJ7-45-1-22-UF-FRONT BOGIE PIVOT BEARING
2	CDRJ7-45-2-01-BG-FRONT BOGIE SIDE FRAME
2	CDRJ7-45-2-02-BG-FRONT BOGIE FRONT AND REAR PLATE
2	CDRJ7-45-2-03-BG-FRONT BOGIE ANGLE BRACKET
1	CDRJ7-45-2-04-BG-FRONT BOGIE LH-RAIL SCOOP
1	CDRJ7-45-2-05-BG-FRONT BOGIE RH-RAIL SCOOP
2	CDRJ7-45-2-06-BG-FRONT BOGIE LEAF SPRING
1	CDRJ7-45-2-07-BG-FRONT BOGIE SWING ARM
2	CDRJ7-45-2-08-BG-FRONT BOGIE WHEEL SPLASHER
6	CDRJ7-45-2-10-BG-BOGIES AXLE BOX KEEPER
6	CDRJ7-45-2-11-BG-BOGIES AXLE BOX
12	CDRJ7-45-2-12-BG-BOGIES LEAF SPRING BRACKET
3	CDRJ7-45-2-13-BG-BOGIES WHEEL AXLE
6	CDRJ7-45-2-14-BG-BOGIES WHEEL
2	CDRJ7-45-2-20-BG-REAR BOGIE SIDE FRAME
2	CDRJ7-45-2-21-BG-REAR BOGIE FRONT AND REAR PLATE
4	CDRJ7-45-2-22-BG-REAR BOGIE LEAF SPRING
2	CDRJ7-45-2-23-BG-REAR BOGIE LEAF SPRING PIVOT BEARING
1	CDRJ7-45-2-24-BG-REAR BOGIE CENTER BRIDGE
8	CDRJ7-45-2-25-BG-REAR BOGIE BRAKE SHOE
8	CDRJ7-45-2-26-BG-REAR BOGIE BRAKE SHOE LEVER
4	CDRJ7-45-2-27-BG-REAR BOGIE BRAKE LEVER CROSS ROD
4	CDRJ7-45-2-28-BG-REAR BOGIE BRAKE LEVER AIR CULINDER CROSS ROD
2	CDRJ7-45-2-29-REAR BOGIE BRAKE AIR CYLINDER
1	CDRJ7-45-2-30-BG-REAR BOGIE AIR CYLINDER MOUNTING BRACKET
1	CDRJ7-45-3-01-EC-BASE PLATE
1	CDRJ7-45-3-02-EC-HOOD
2	CDRJ7-45-3-03-EC-SIDE VENTILATION LOUVRES
4	CDRJ7-45-3-04-EC-5 VENTS
2	CDRJ7-45-3-05-EC-14 VENTS
1	CDRJ7-45-3-06-EC-RADIATOR
1	CDRJ7-45-3-07-EC-RADIATOR COOLING FINS
1	CDRJ7-45-3-08-EC-FRONT COVER PLATE
1	CDRJ7-45-3-09-EC-STARTING CRANK HANDLE TUBE
1	CDRJ7-45-3-10-EC-STARTIG CRANK HANDLE
1	CDRJ7-45-3-11-EC-HOOD TO COMPARTMENT MOUNTING PLATE
1	CDRJ7-45-4-01-PC-FLOOR
1	CDRJ7-45-4-02-PC-COMPARTMENT
1	CDRJ7-45-4-03-PCFRONT WINDOW PANEL
1	CDRJ7-45-4-03-PCFRONT WINDOW PANEL
1	CDRJ7-45-4-04-PC-FRONT AND REAR DOOR SIDE FRAME
3	CDRJ7-45-4-04-PC-FRONT AND REAR DOOR SIDE FRAME
1	CDRJ7-45-4-05-PC-FRONT DOOR LINTEL
1	CDRJ7-45-4-06-PC-REAR DOOR LINTEL
2	CDRJ7-45-4-07-PC-REAR DOOR
2	CDRJ7-45-4-08-PC-FRONT DOOR
2	CDRJ7-45-4-09-PC-FRONT WINDOW AND TRIM
2	CDRJ7-45-4-10-PC-REAR WINDOW AND TRIM
8	CDRJ7-45-4-11-PC-LARGE SIDE WINDOW AND TRIM
1	CDRJ7-45-4-12-PC-REAR SIDE WINDOW AND TRIM
1	CDRJ7-45-4-13-PC-FRONT SIDE WINDOW AND TRIM
1	CDRJ7-45-4-14-PC-SMALL SIDE WINDOW AND TRIM
1	CDRJ7-45-4-15-PC-DRIVERS SEAT
14	CDRJ7-45-4-16-PC-PASSENGERS SEAT
1	CDRJ7-45-4-17-PC-REAR PASSENGERS SEAT
1	CDRJ7-45-4-18-PC-ROOF
1	CDRJ7-45-4-19-PC-ROOF RACK
1	CDRJ7-45-4-20-PC-REAR LADDER
1	CDRJ7-45-4-21-PC-HEAD LIGHT
2	CDRJ7-45-4-22-PC-BODY TRIM
34	CDRJ7-45-M1.5 NUT
23	CDRJ7-45-M1.5x3 R-HEAD SCREW
33	CDRJ7-45-M1.5x5 R-HEAD SCREW
2	CDRJ7-45-M1.5x6.5 R-HEAD SCREW
1	CDRJ7-45-RAIL TRACK 045mm (1.77in)

NOTES:
 TITLE
 IRISH RAILCAR No7 OF THE COUNTY DONEGAL
 RAILWAY JOINT COMMITTEE

DRAWING CONTENTS
 ISOMETRIC VIEWS AND BILL OF
 MATERIALS

PROJECT No
 JDW DRAUGHTING SERVICES
 J.A.M. DE WAAL, 12 BRIGHTWELL STREET PAPAURA 2110.
 NEW ZEALAND. PHONE: 0064 09 2988815. MOB: 0211791000
 E-MAIL: dewaal@xtra.co.nz.

PROJECTION
 DATE
 DECEMBER 2010
 SHEET:02 OF 08

MODEL SCALE: 1:20.3 (GAUGE 1:45mm)
 DWG SCALE: NTS @A3 OR AS SHOWN
 Copyright © J. DE WAAL PAPAURA NZ
 A3 CDRJ7-45-02

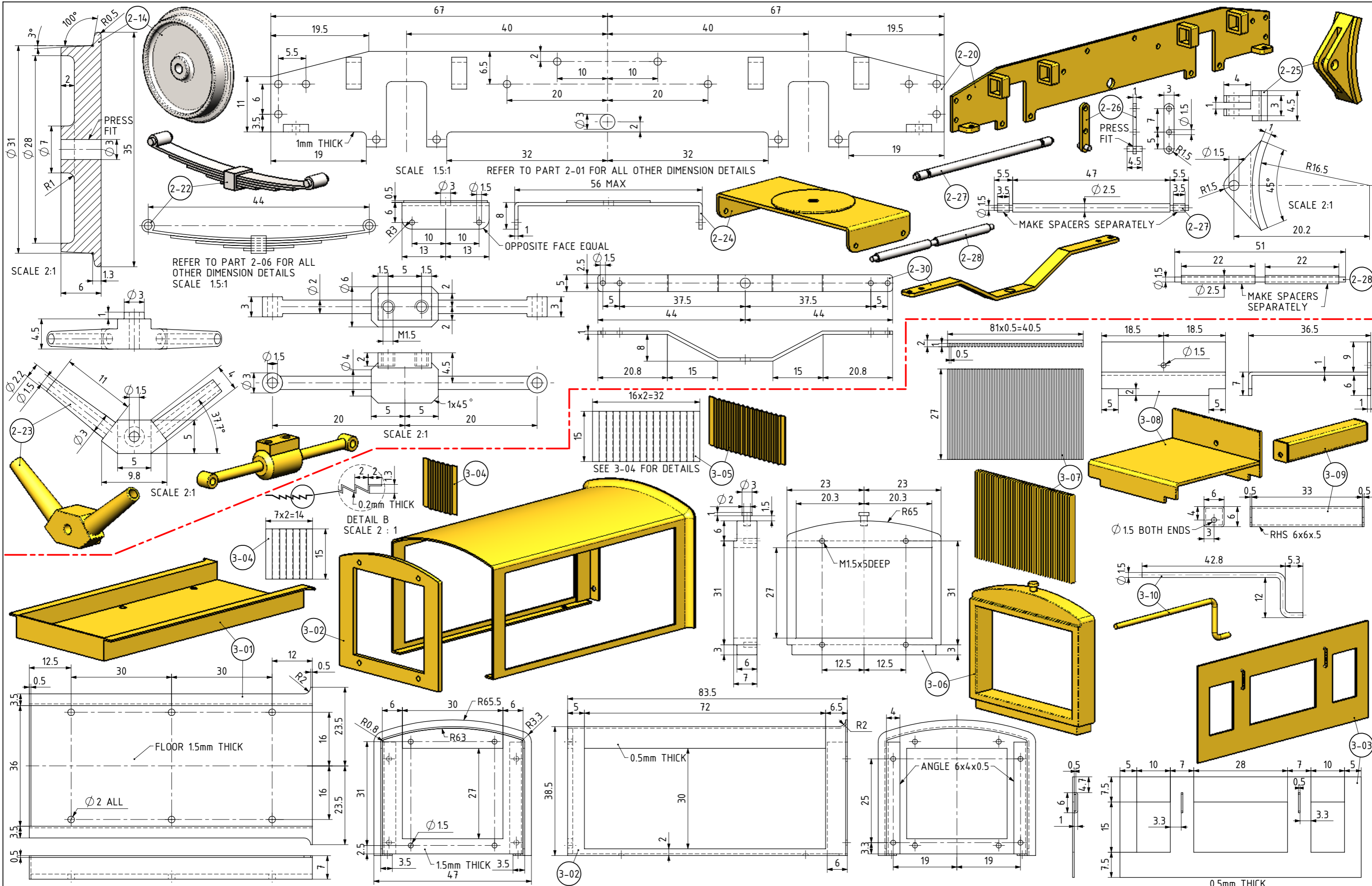

NOTES:
 TITLE
IRISH RAILCAR No7 OF THE COUNTY DONEGAL RAILWAY JOINT COMMITTEE

DRAWING CONTENTS
PARTS AND ASSEMBLIES

PROJECT No
JDW DRAUGHTING SERVICES
 J.A.M. DE WAAL, 12 BRIGHTWELL STREET PAPAURA 2110.
 NEW ZEALAND. PHONE: 0064 09 2988815. MOB: 0211791000
 E-MAIL: dewaal@xtra.co.nz.

PROJECTION
 DATE
DECEMBER-2010
 SHEET:04 OF 08

MODEL SCALE: 1:20.3 (GAUGE 1:45mm)
 DWG SCALE: 1:1 @A3 OR AS SHOWN
 Copyright © J. DE WAAL PAPAURA NZ
A3 CDRJC7-45-04

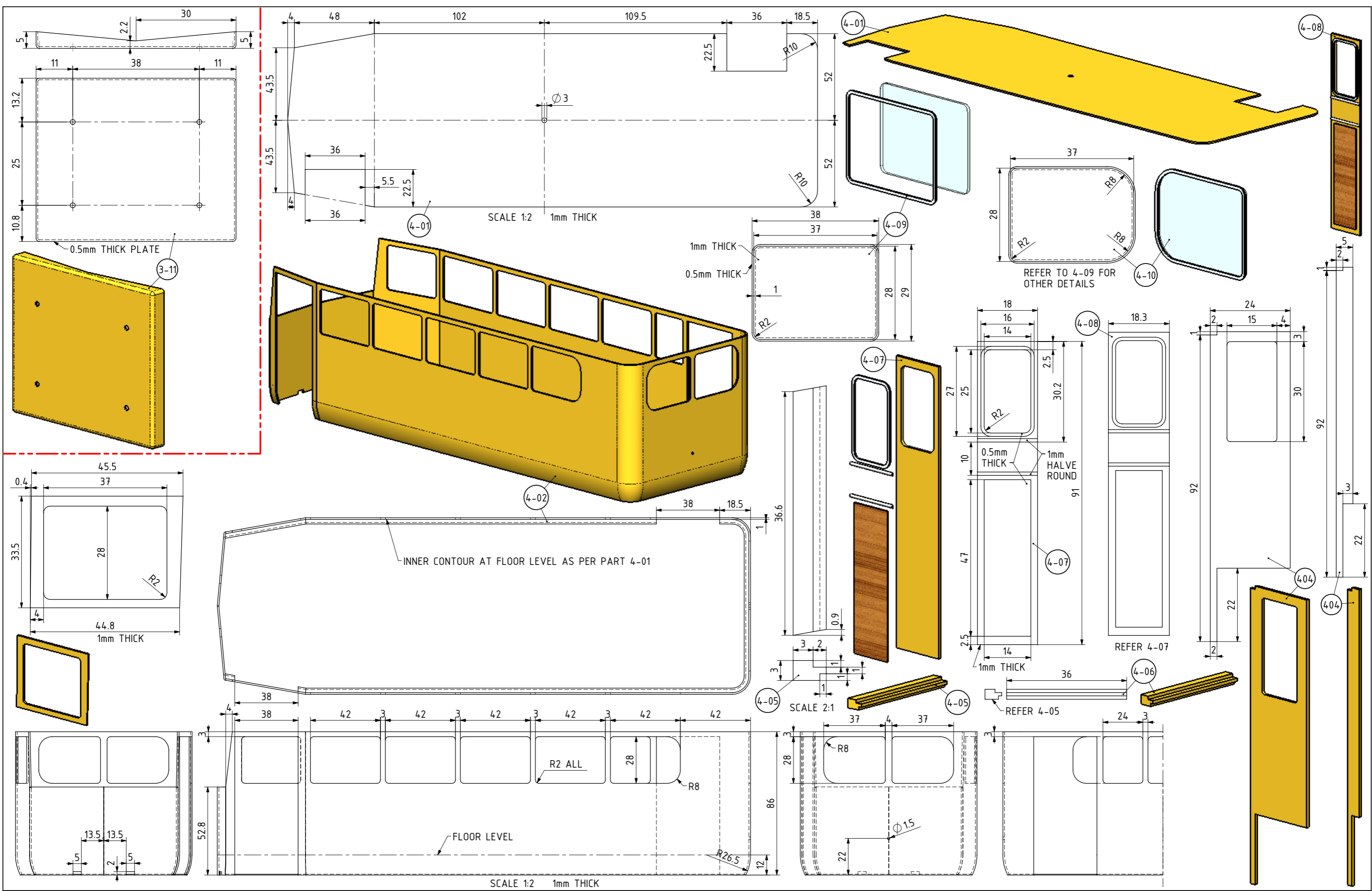

NOTES:
 TITLE
 IRISH RAILCAR No7 OF THE COUNTY DONEGAL
 RAILWAY JOINT COMMITTEE

DRAWING CONTENTS
 PARTS AND ASSEMBLIES

PROJECT No
 JDW DRAUGHTING SERVICES
 J.A.M. DE WAAL, 12 BRIGHTWELL STREET PAPAOKURA 2110.
 NEW ZEALAND. PHONE: 0064 09 2988815. MOB: 0211791000
 E-MAIL: dewaal@xtra.co.nz.

PROJECTION
 DATE
 DECEMBER-2010
 SHEET:05 OF 08

MODEL SCALE: 1:20.3 (GAUGE 1:45mm)
 DWG SCALE: 1:1 @A3 OR AS SHOWN
 Copyright © J. DE WAAL PAPAOKURA NZ
 A3 CDRJC7-45-05

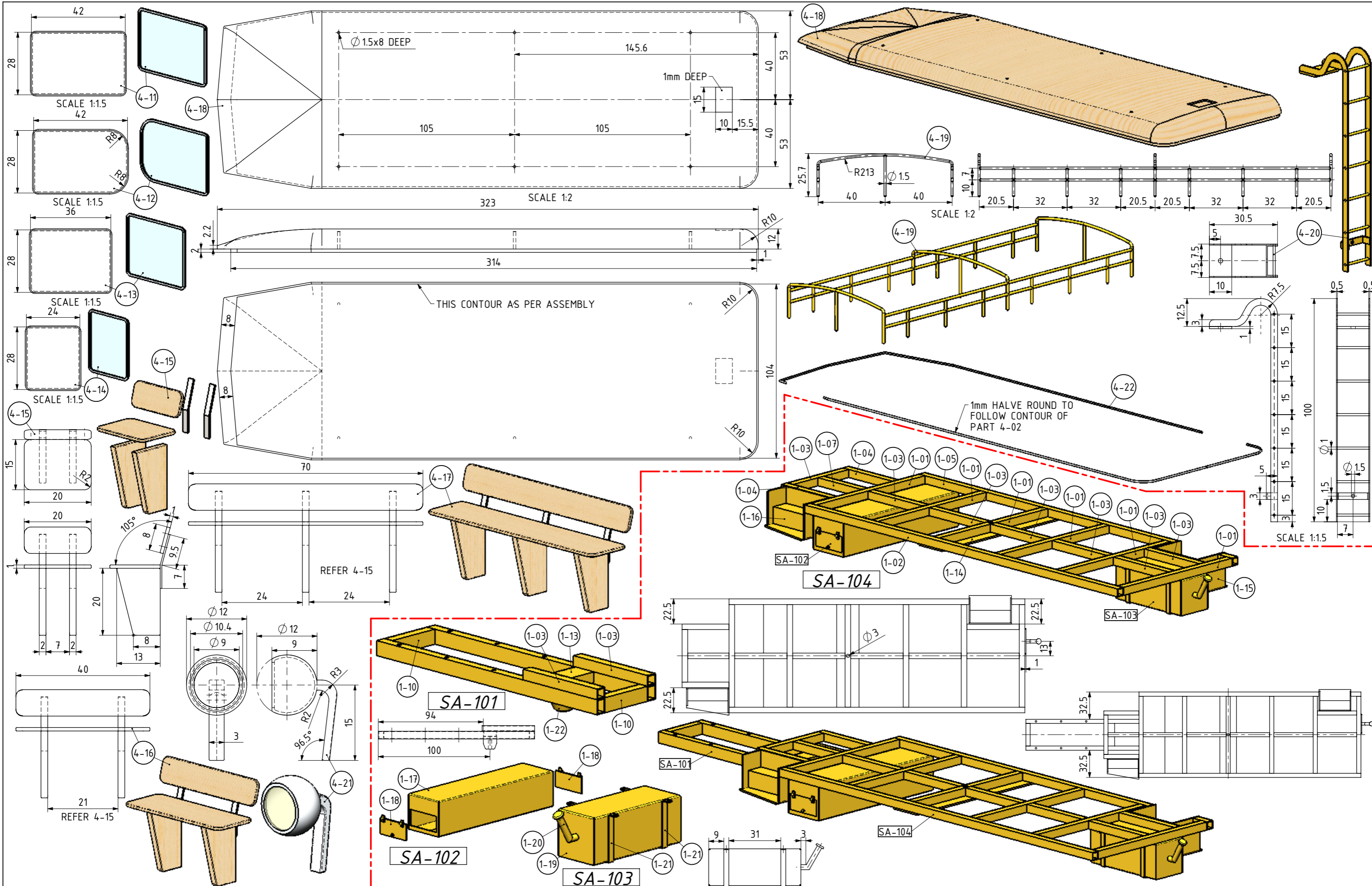

NOTES:
 TITLE
IRISH RAILCAR No7 OF THE COUNTY DONEGAL
RAILWAY JOINT COMMITTEE

DRAWING CONTENTS
PARTS AND ASSEMBLIES

PROJECT No
JDW DRAUGHTING SERVICES
 J.A.M. DE WAAL, 12 BRIGHTWELL STREET PAPAOKURA 2110.
 NEW ZEALAND. PHONE: 0064 09 2988815. MOB: 0211791000
 E-MAIL: dewaal@xtra.co.nz.

PROJECTION
 DATE
DECEMBER-2010
 SHEET:06 OF 08

MODEL SCALE: 1:20.3 (GAUGE 1:45mm)
 DWG SCALE: 1:1 @A3 OR AS SHOWN
 Copyright © J. DE WAAL PAPAOKURA NZ
A3 CDRJC7-45-06

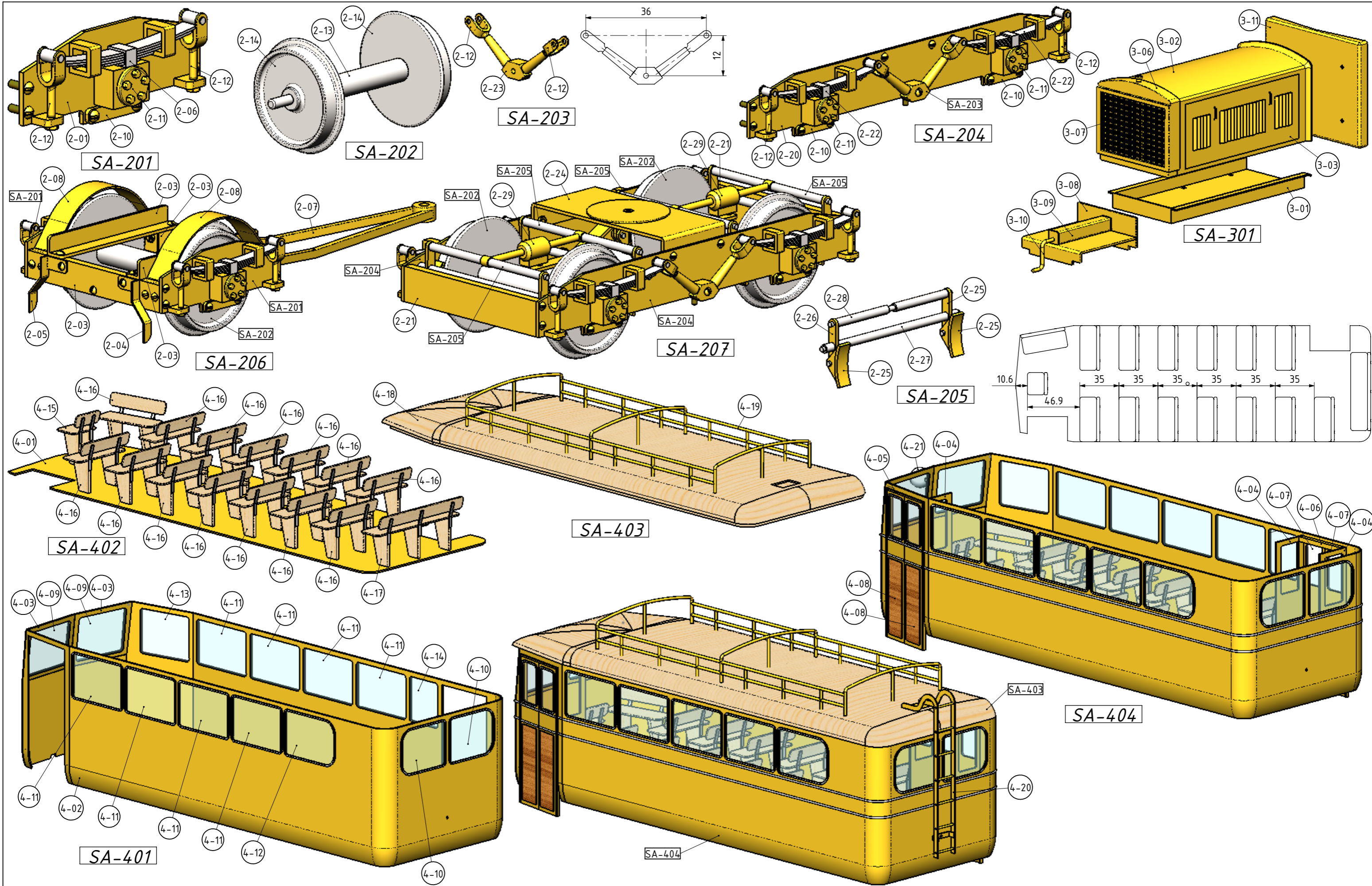

NOTES:
 TITLE
 IRISH RAILCAR No7 OF THE COUNTY DONEGAL
 RAILWAY JOINT COMMITTEE

DRAWING CONTENTS
 PARTS AND ASSEMBLIES

PROJECT No
 JDW DRAUGHTING SERVICES
 J.A.M. DE WAAL, 12 BRIGHTWELL STREET PAPAURA 2110.
 NEW ZEALAND. PHONE: 0064 09 2988815. MOB: 0211791000
 E-MAIL: dewaal@xtra.co.nz.

PROJECTION
 DATE
 DECEMBER-2010
 SHEET:07 OF 08

MODEL SCALE: 1:20.3 (GAUGE 1:45mm)
 DWG SCALE: 1:1 @A3 OR AS SHOWN
 Copyright © J. DE WAAL PAPAURA NZ
 A3
 CDRJC7-45-07

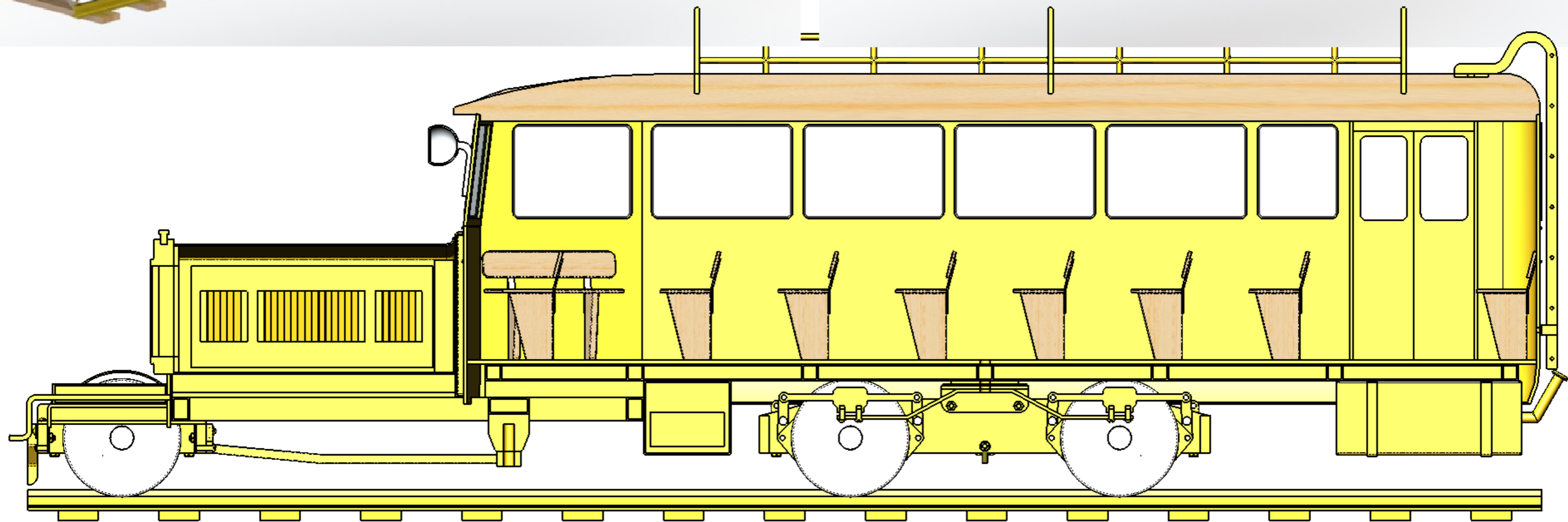
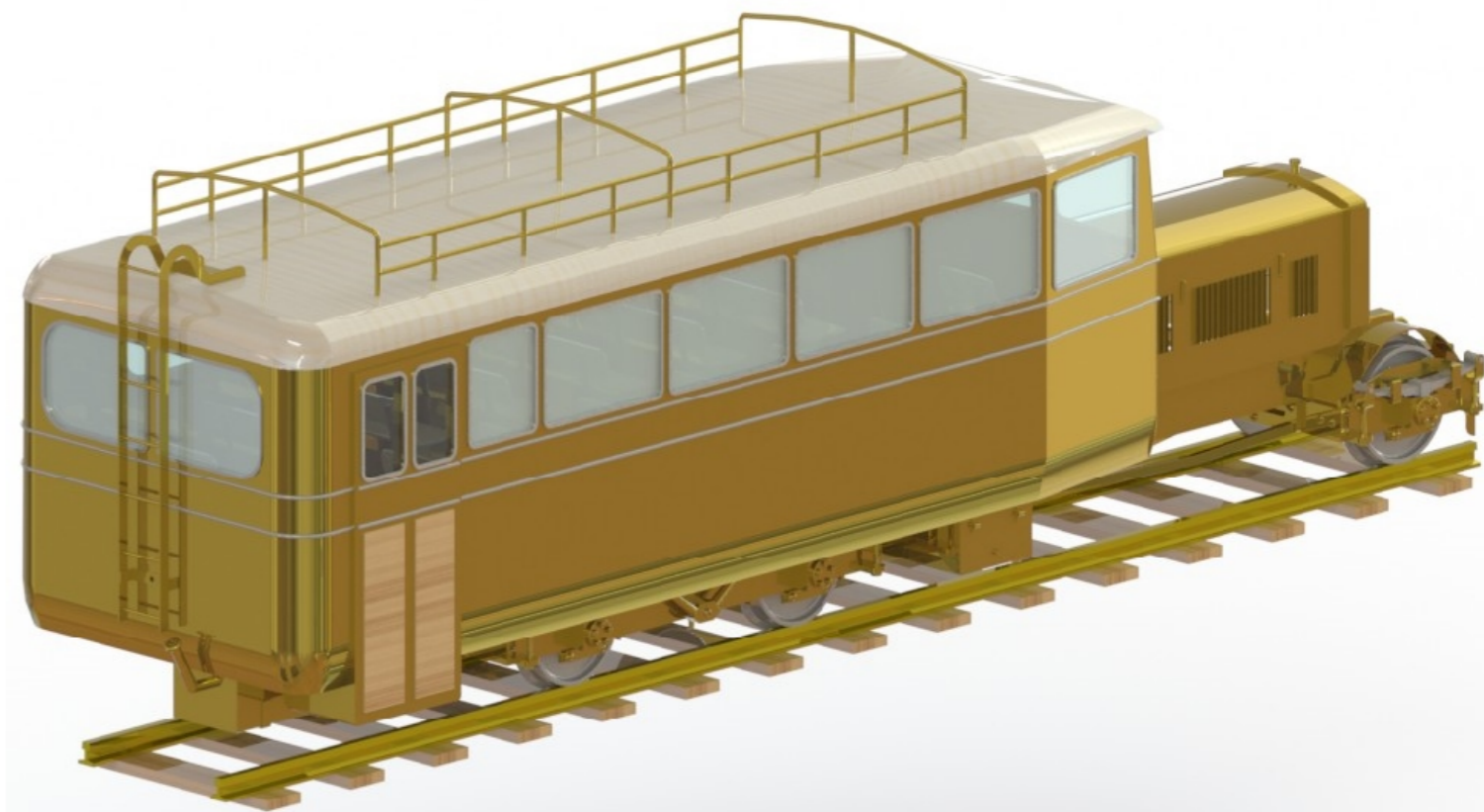
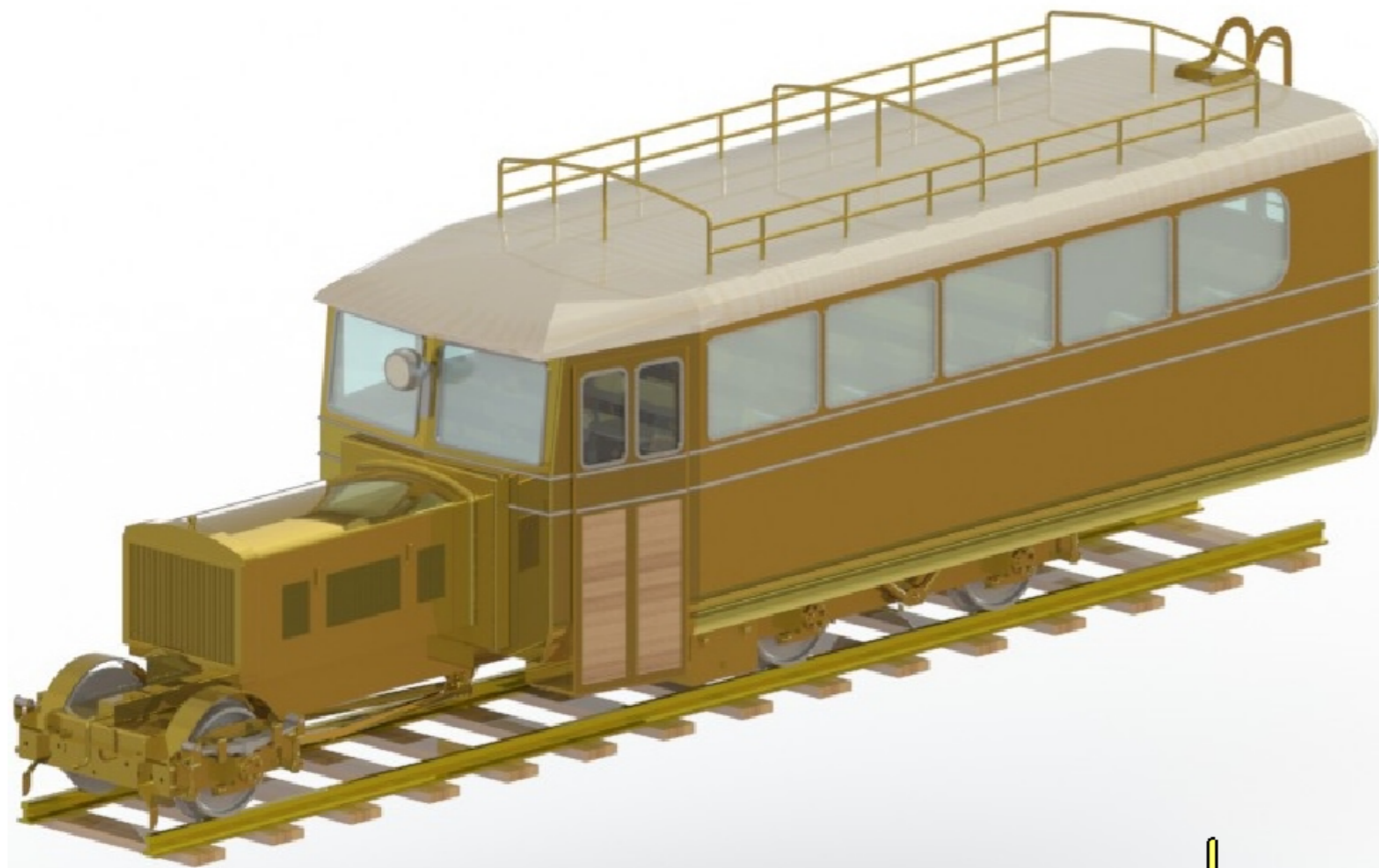

NOTES:

TITLE
IRISH RAILCAR No7 OF THE C.D.R.J.C.

DRAWING CONTENTS
RENDERED ISOMETRIC VIEW AND SECTION

PROJECT No
JDW DRAUGHTING SERVICES
J.A.M. DE WAAL, 12 BRIGHTWELL STREET PAKAPURA 2110.
NEW ZEALAND. PHONE: 0064 09 2988815. MOB: 0211791000
E-MAIL: dewaal@xtra.co.nz.

PROJECTION
DATE NOVEMBER-2013
SHEET:08 OF 08

MODEL SCALE: 1:20.3 (GAUGE 1:45mm)
DWG SCALE: NTS @A3 OR AS SHOWN
Copyright © J. DE WAAL PAKAPURA NZ
A3 CDRJC7-45-08

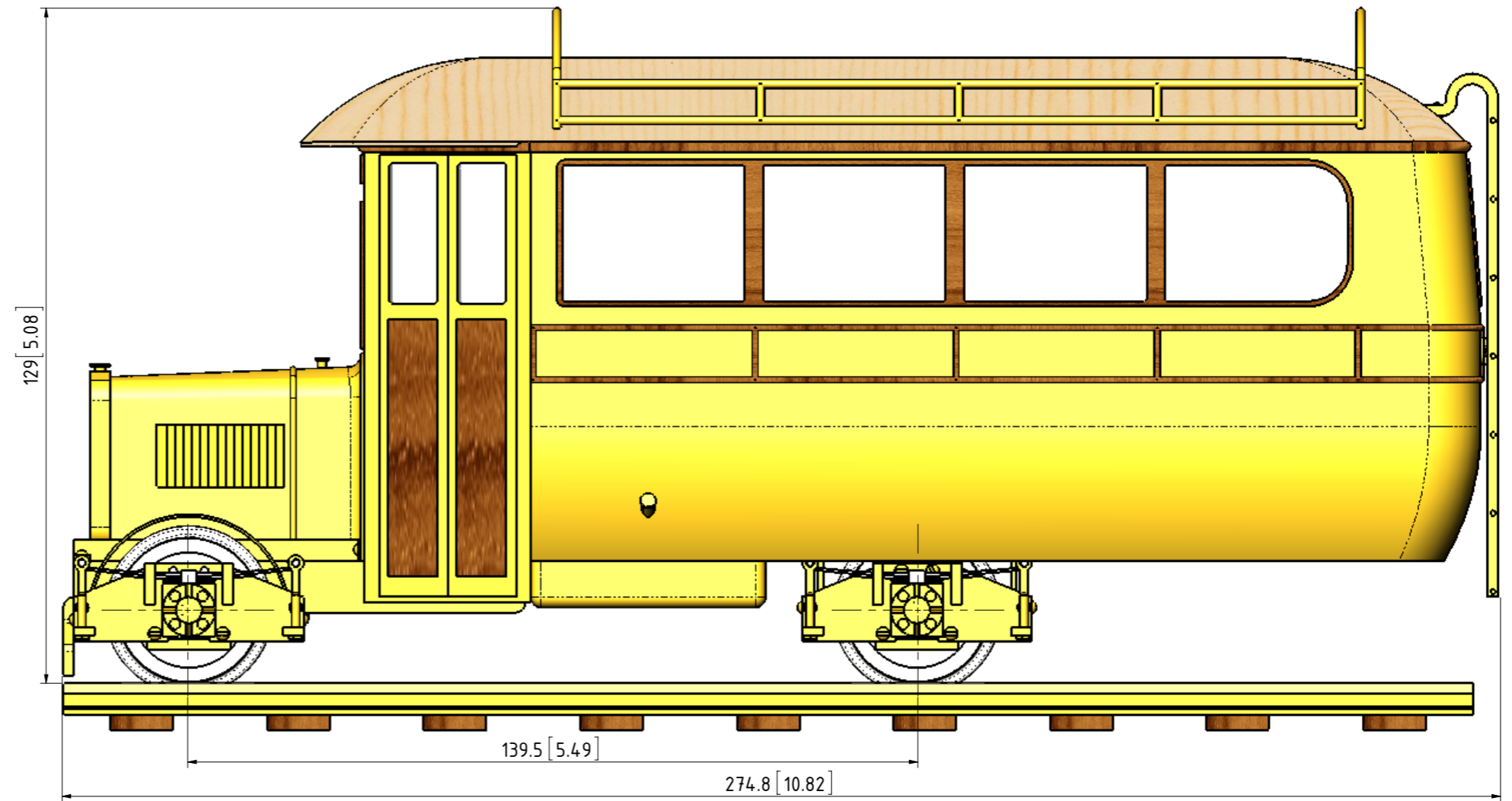
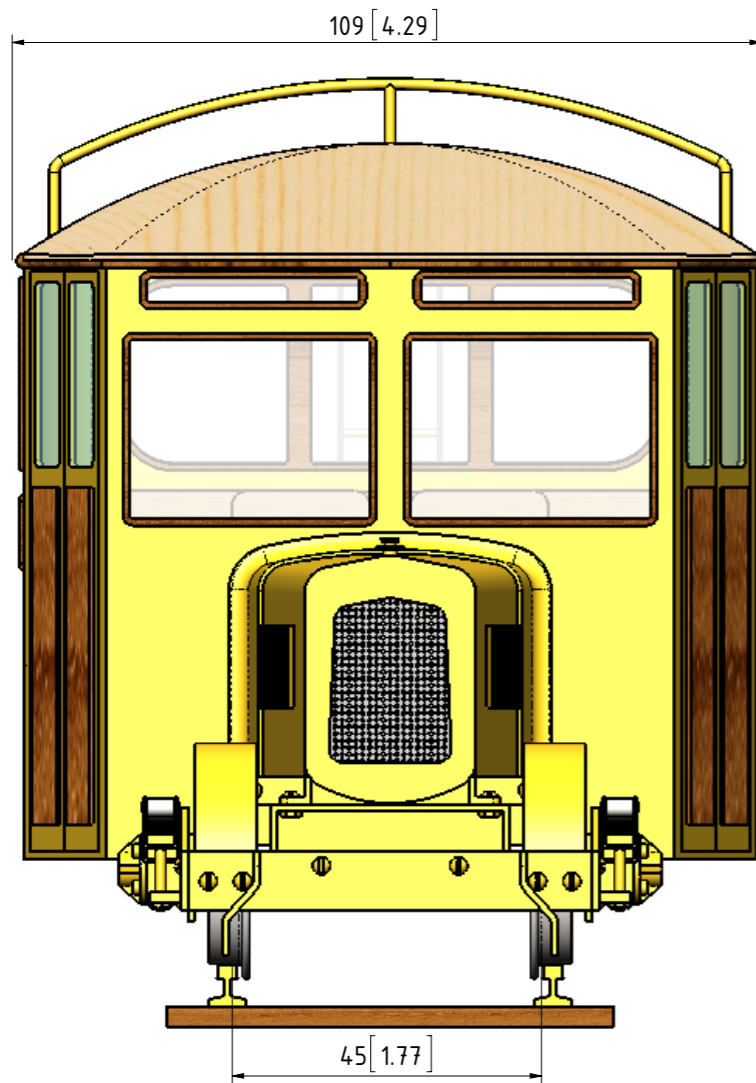
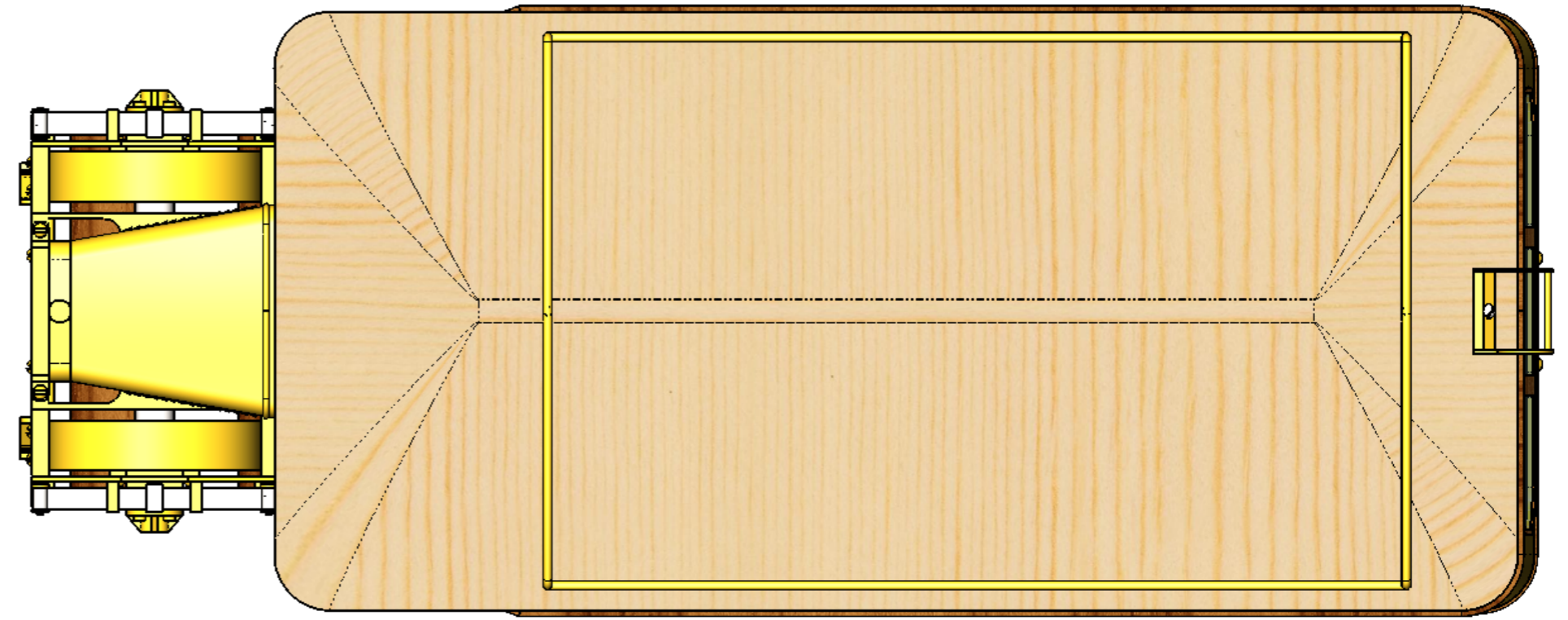

NOTES: C.D.R.J.C.=COUNTY DONEGAL RAILWAY JOINT COMMITTEE

TITLE
IRISH RAILCAR C.D.R.J.C. No4 (1928) MODEL SCALE 1:20.3 TRACK GAUGE 45mm GENERAL ARRANGEMENT

			JDW DRAUGHTING SERVICES 12 BRIGHTWELL STREET PAPAKURA NEW ZEALAND TEL/FAX 0064-09-2988815 E-MAIL:dewaal@xtra.co.nz
A	ISSUED FOR CONSTRUCTION		
REV	DESCRIPTION	DATE	

DRAWN BY J.A.M. DE WAAL	PROJECT No: 01-04-04-06-00	DRAWING NUMBER DRJC.4-45	SHEET 1
DATE DECEMBER 2010	SCALE NTS@A3 or AS SHOWN	SHT OF SHT 1 of 6	REV A

IF NOT STATED ALL CHAMFERS AND FILLETS 0.1mm

DO NOT SCALE OF DRAWING

REMOVE ALL BURS AND SHARP EDGES

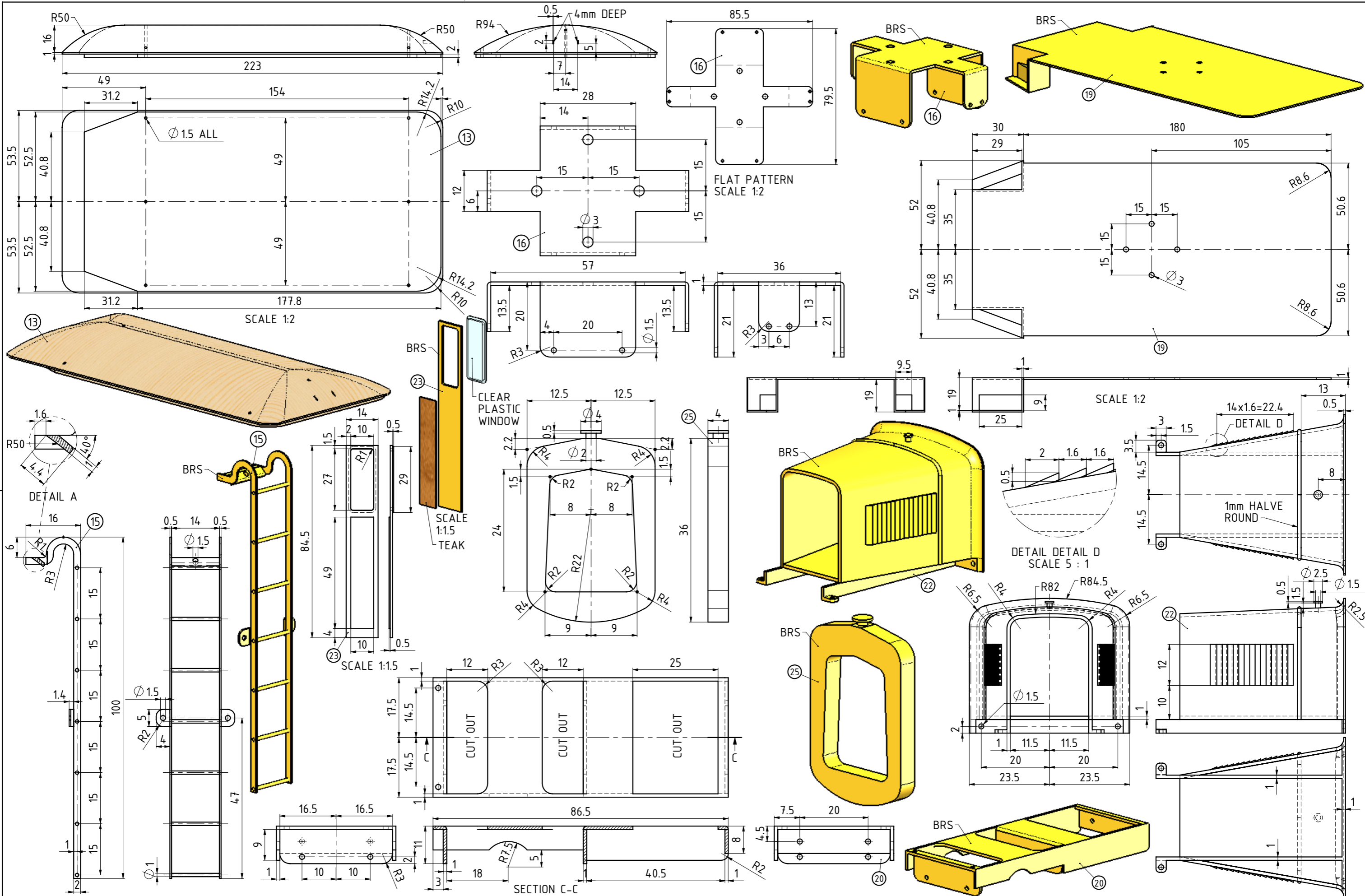

NOTES: M/S=MILD STEEL S/S=STAINLESS STEEL OR SILVERSTEEL BRS=BRASS BRZ=BRONZE SP/S SPRING STEEL

TITLE
IRISH RAILCAR C.D.R.J.C. No4 (1928) MODEL SCALE 1:20.3 TRACK
A3 GAUGE 45mm PARTS

JDW DRAUGHTING SERVICES
 12 BRIGHTWELL STREET
 PAKAPURA NEW ZEALAND
 TEL/FAX 0064-09-2988815
 E-MAIL:dewaal@xtra.co.nz

PROJECT No:	01-04-04-06-00
DRAWN BY	J.A.M. DE WAAL
PROJECTION	DRJC.4-45
DATE	DECEMBER 2010
SCALE	2:1@A3 or AS SHOWN
SHT OF SHT	3 of 6
REV	A

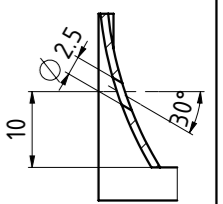
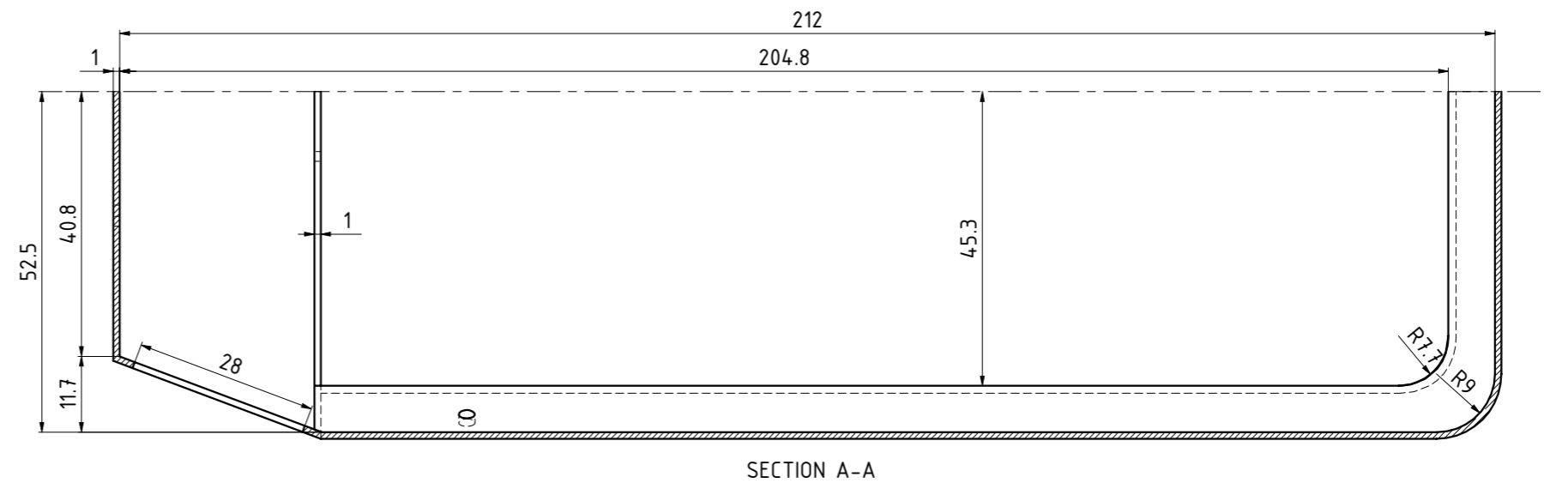
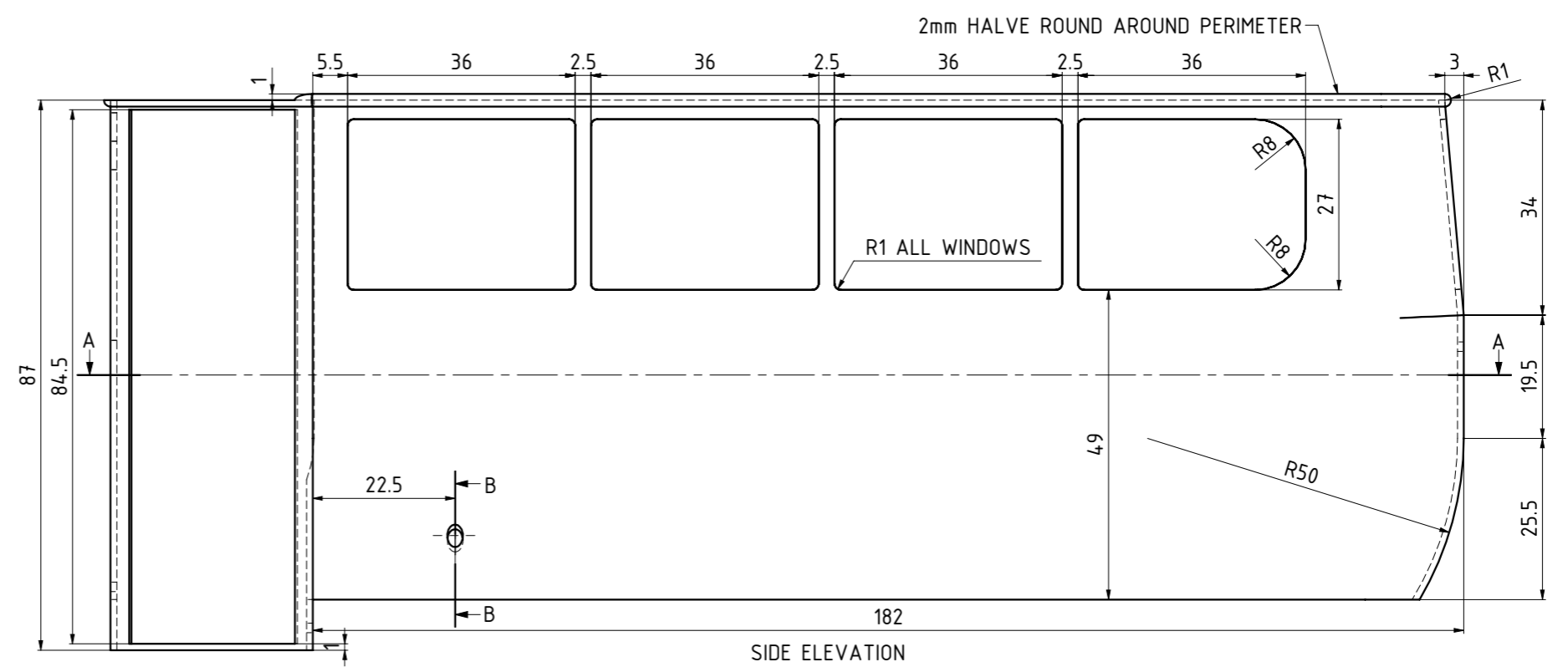
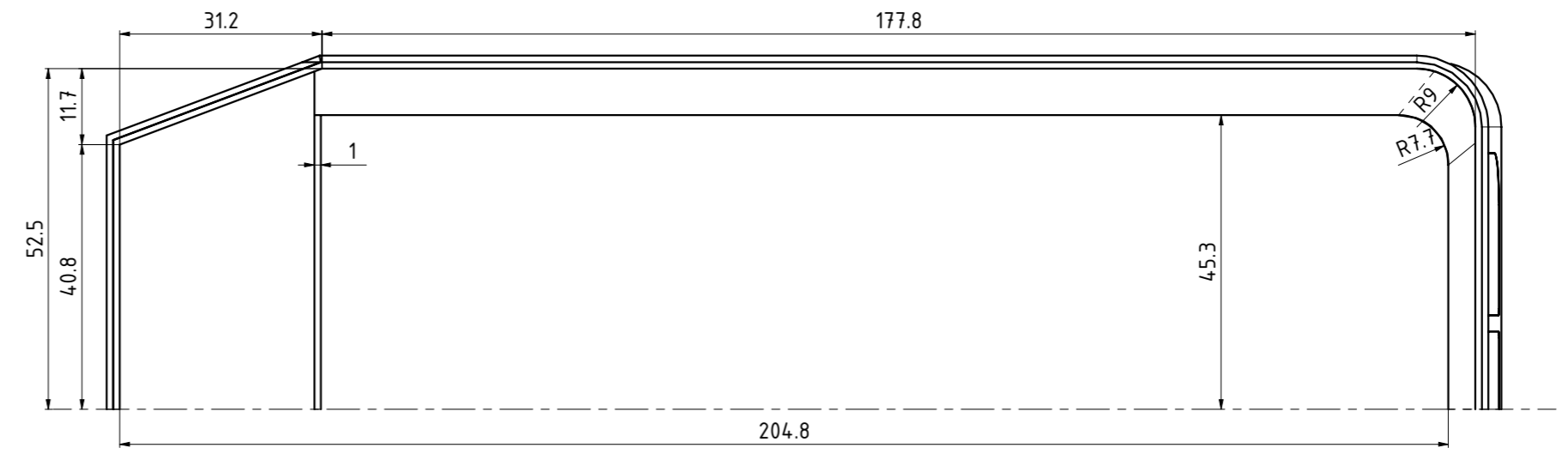
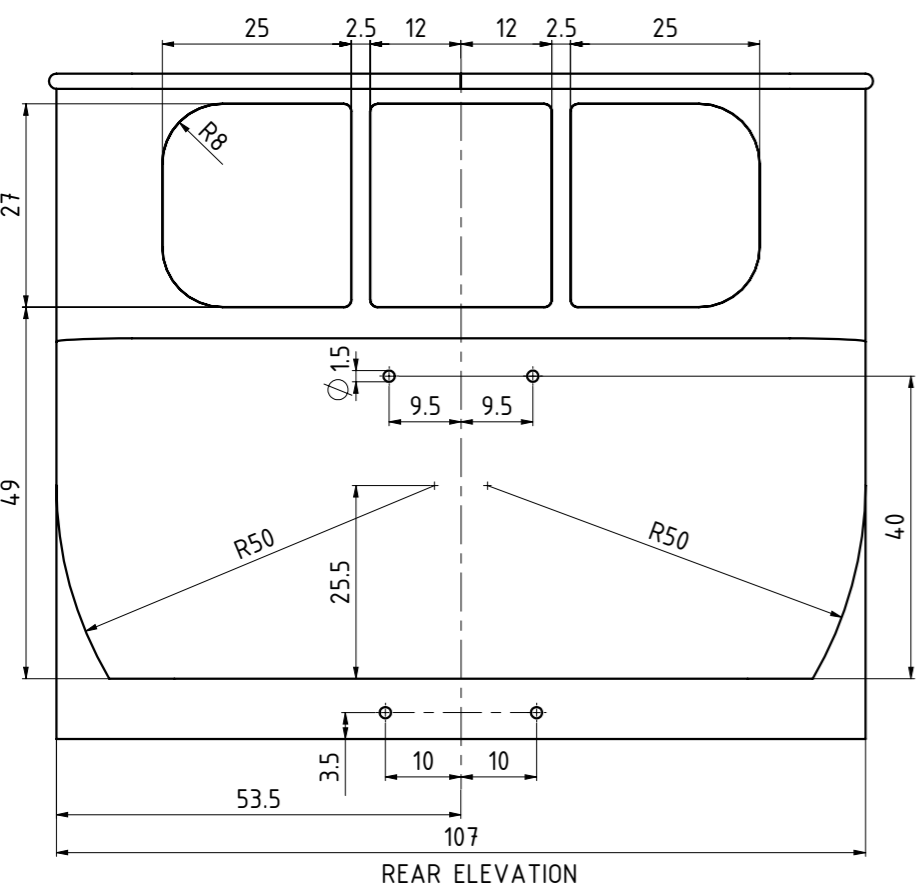
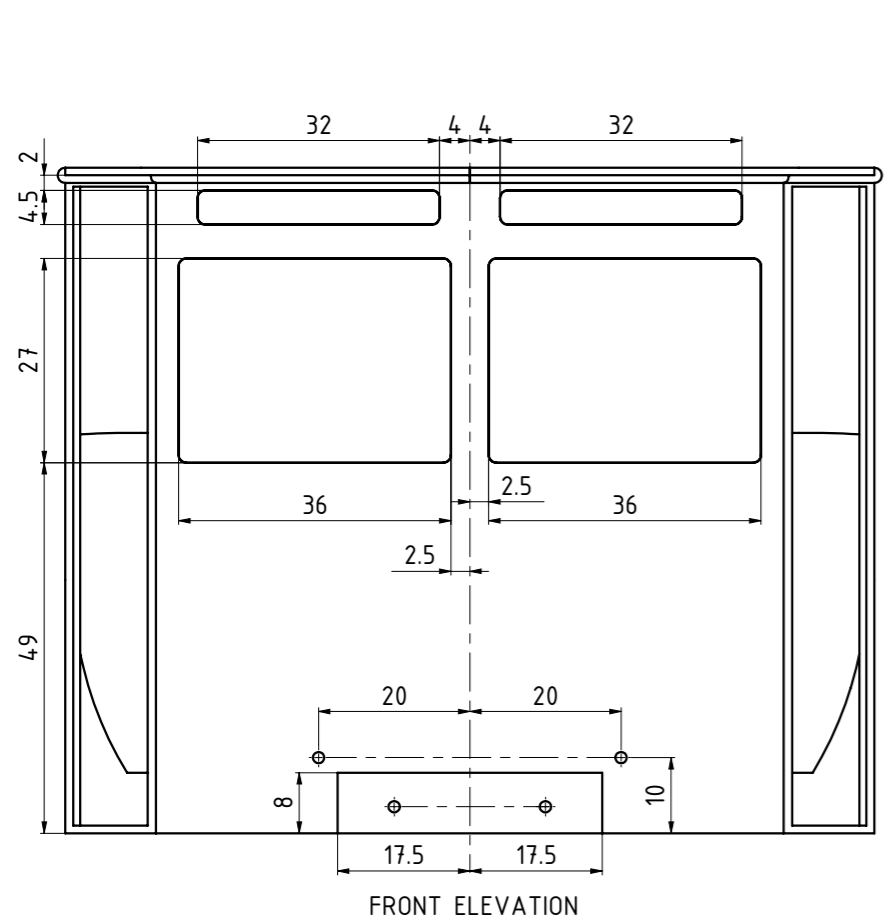

NOTE: ALL WINDOW FRAMES ARE FITTED WITH CLEAR PLASTIS WINDOWS

NOTES: M/S=MILD STEEL S/S=STAINLESS STEEL OR SILVERSTEEL BRS=BRASS BRZ=BRONZE SP/S SPRING STEEL

A3 IRISH RAILCAR C.D.R.J.C. No4 (1928) MODEL SCALE 1:20.3 TRACK GAUGE 45mm PARTS

JDW DRAUGHTING SERVICES 12 BRIGHTWELL STREET PAKAKURA NEW ZEALAND TEL/FAX 0064-09-2988815 E-MAIL:dewaal@xtra.co.nz	DRAWN BY J.A.M. DE WAAL	DATE DECEMBER 2010
ISSUED FOR CONSTRUCTION		
DESCRIPTION		

PROJECT No: 01-04-04-06-00	DRAWING NUMBER DRJC.4-45	SHEET 4
SCALE 2:1@A3 or AS SHOWN	ISHT OF SHIT 4 of 6	REV A

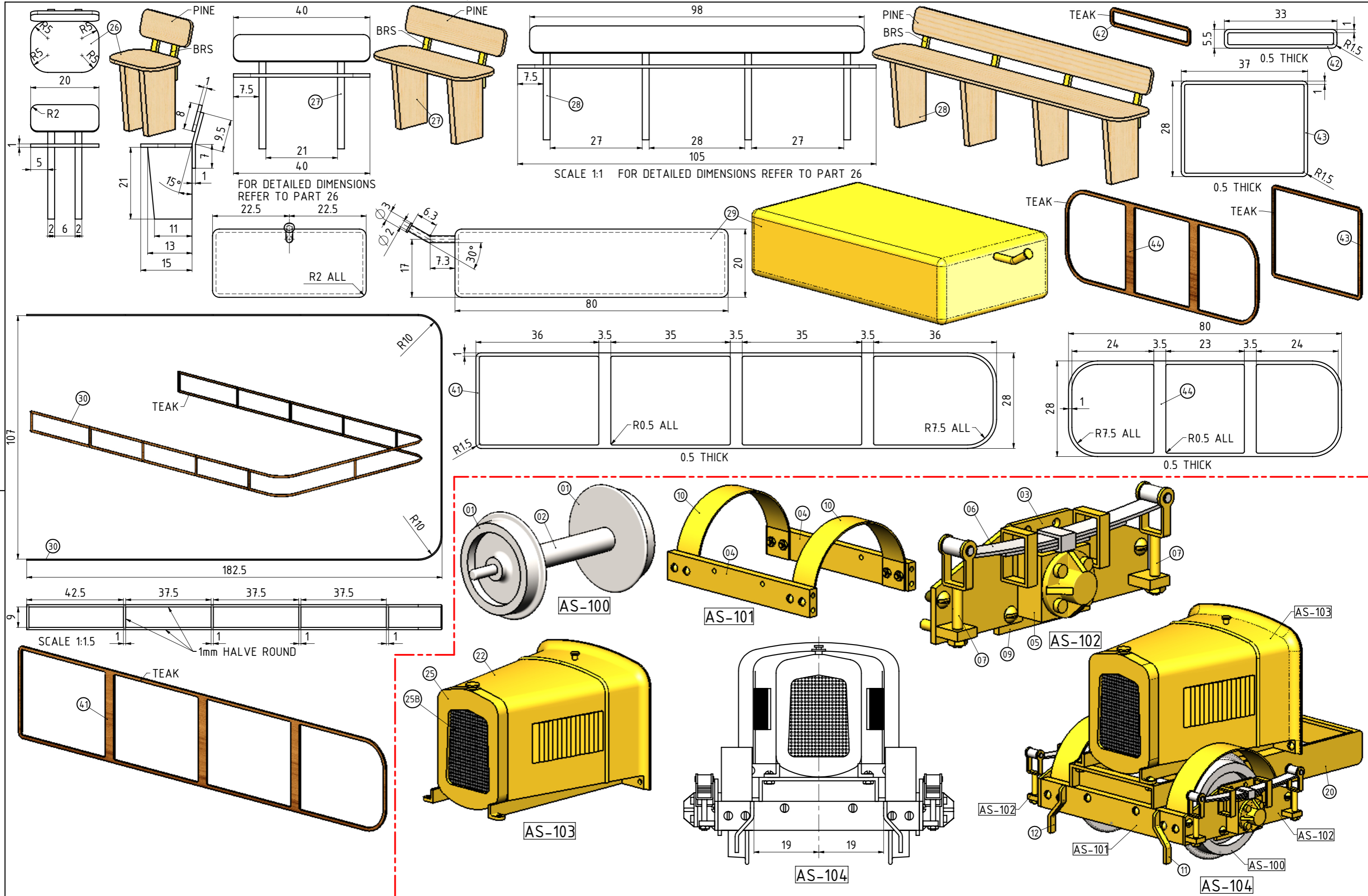

NOTES:

TITLE
IRISH RAILCAR C.D.R.J.C. No4 (1928) MODEL SCALE 1:20.3 TRACK GAUGE 45mm PARTS AND ASSEMBLIES

JDW DRAUGHTING SERVICES
 12 BRIGHTWELL STREET
 PAKAPURA NEW ZEALAND
 TEL/FAX 0064-09-2988815
 E-MAIL:dewaal@xtra.co.nz

DRAWN BY
J.A.M. DE WAAL
 DATE
 DECEMBER 2010

PROJECT No: 01-04-04-06-00
 DRAWING NUMBER
DRJC.4-45
 SHEET
5
 SCALE 2:1@A3 or AS SHOWN
 5 of 6
 REV
A

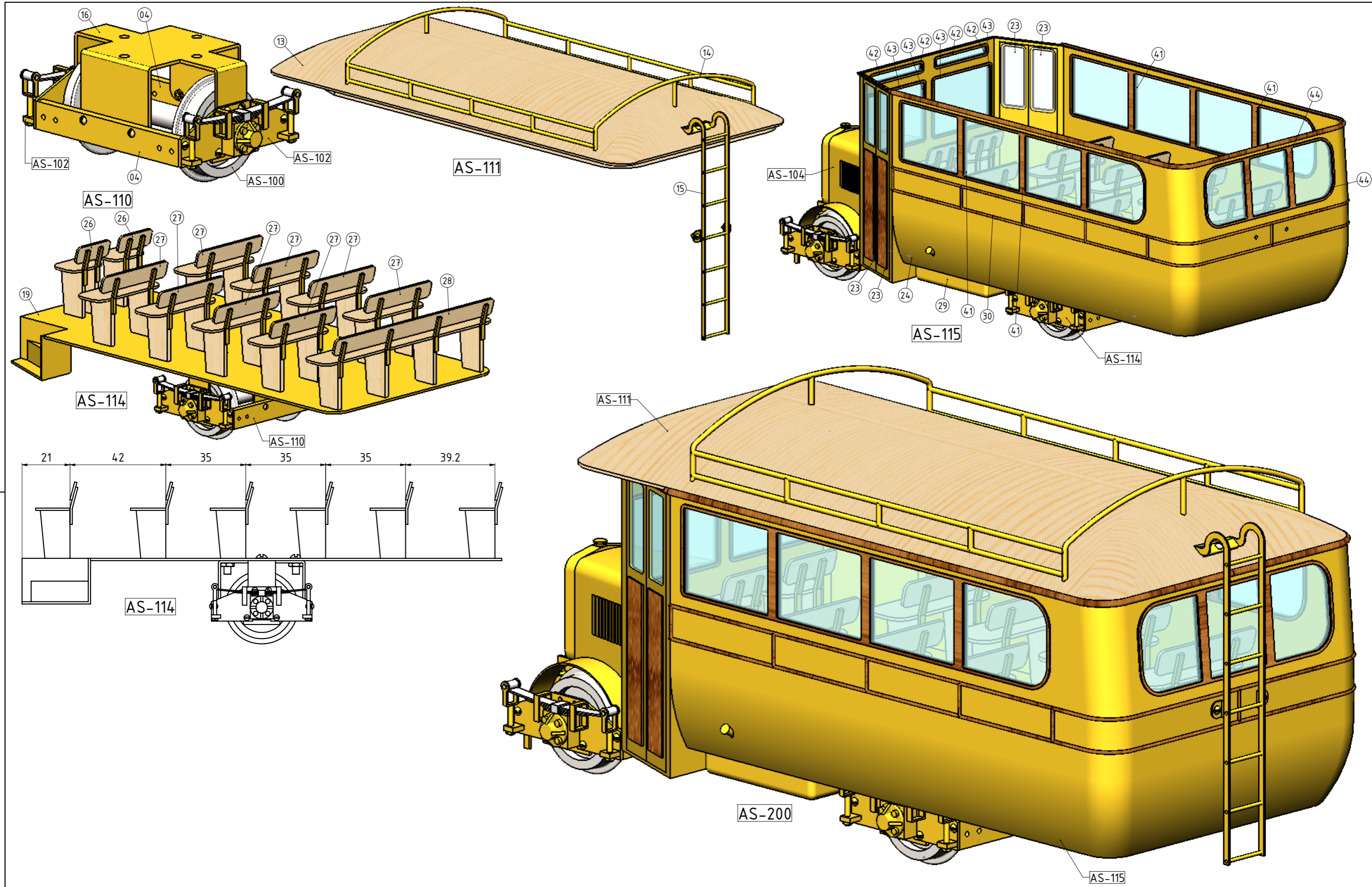

NOTES:

A3 TITLE IRISH RAILCAR C.D.R.J.C. No4 (1928) MODEL SCALE 1:20.3 TRACK GAUGE 45mm PARTS

			JDW DRAUGHTING SERVICES 12 BRIGHTWELL STREET PAPAURA NEW ZEALAND TEL/FAX 0064-09-2988815 E-MAIL:dewaal@xtra.co.nz
A	ISSUED FOR CONSTRUCTION		
REV	DESCRIPTION	DATE	

DRAWN BY J.A.M. DE WAAL	PROJECT No: 01-04-04-06-00	DRAWING NUMBER DRJC.4-45	SHEET 6
DATE DECEMBER 2010	SCALE N.T.S. or AS SHOWN	SHT OF SHT 6 of 6	REV A

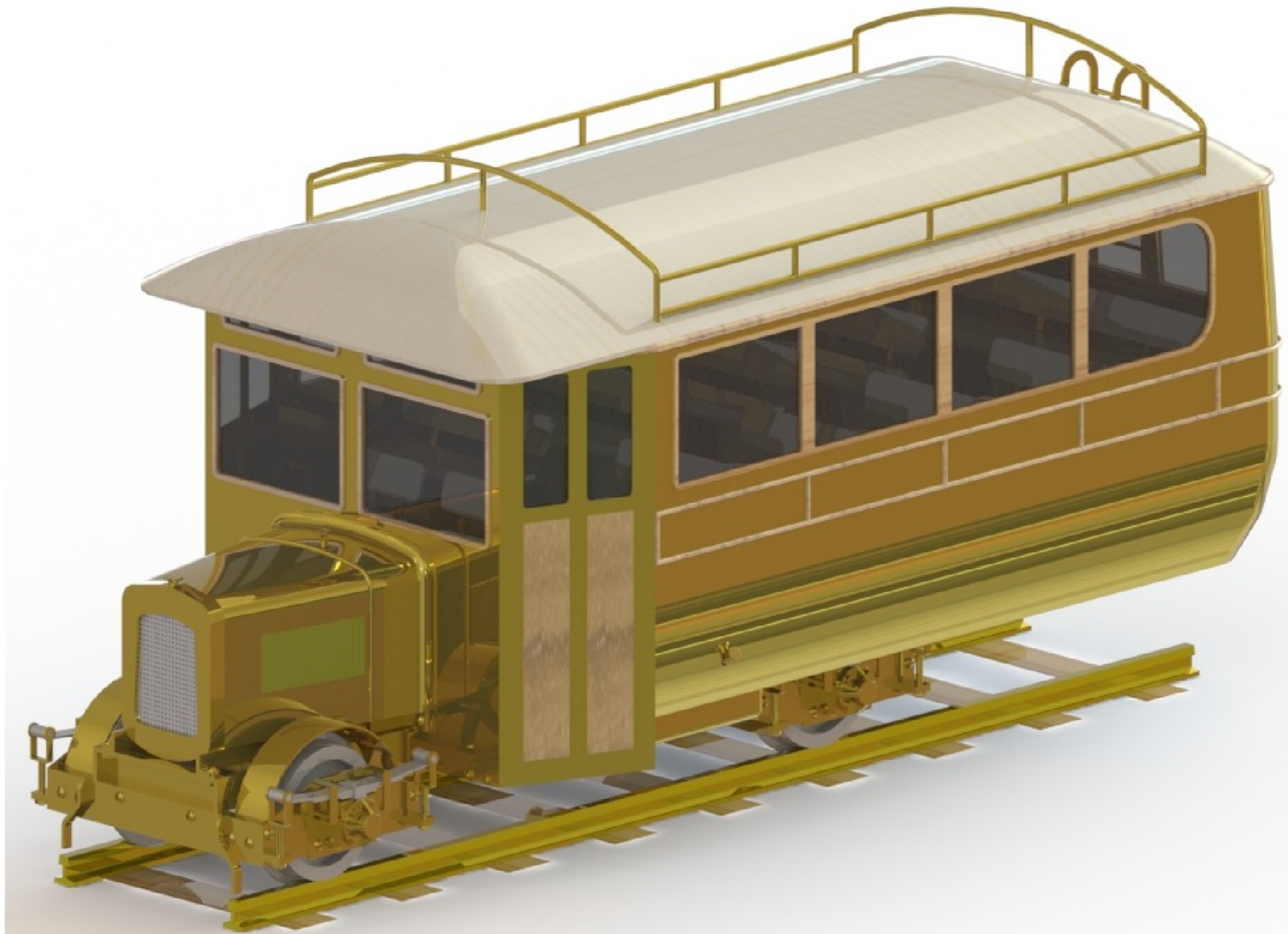

NOTES: C.D.R.J.C.=COUNTY DONEGAL RAILWAY JOINT COMMITTEE

A3 TITLE IRISH RAILCAR C.D.R.J.C. No4 (1928) MODEL SCALE 1:20.3 TRACK GAUGE 45mm RENDERED PICTURE

REV	DESCRIPTION	DATE
A	ISSUED FOR CONSTRUCTION	

JDW DRAUGHTING SERVICES
 12 BRIGHTWELL STREET
 PAKAKURA NEW ZEALAND
 TEL/FAX 0064-09-2988815
 E-MAIL:dewaal@xtra.co.nz

DRAWN BY J.A.M. DE WAAL
 DATE DECEMBER 2010

PROJECT No:	01-04-04-06-00
DRAWING NUMBER	DRJC.4-45
SCALE	NTS@A3 or AS SHOWN
SHEET OF SHEET	A