

Leaders In Efficient Concrete Construction

Hollow Core Concrete Pty. Ltd.

Since its establishment in 1988, Hollow Core Concrete Pty. Ltd. has developed a reputation for excellence in the provision of cost efficient precast structural systems. As industry leaders, Hollow Core has served an array of prestigious clients and has assisted them in achieving quality outcomes which are both economic and reliable.

The aim of our company is to provide cost effective structural design and products which are of the highest standard.

With the assistance of our own specialist in-house design team, we are able to provide clients and their project consultants with design and feasibility solutions which utilise Hollow Core's products. From the initial concept to the final design, this co-operative approach to construction reduces costs, improves quality, and results in an efficient use of resources. By combining our renowned expertise with the use of precast products, Hollow Core is able to deliver a total precast structural solution that meets specific construction needs.

Hollow Core's range of products include:

- Floor planks: Hollow Core and Minislabs (thin flat slabs)
- Precast/prestressed beams and columns
- Precast reinforced stairs and landings
- Precast wall panels
- Precast/prestressed piles
- Prestressed stadium seating units
- Acoustic Panels: both Absorptive Soundtrap® and reflective noise panels
- Termodeck® Hollow Core floor planks



The precast skeletal frame of this four level office development was constructed in just 26 days.



The re-development of Melbourne's GPO. Precast balcony units cantilever in two directions.



State of the art European technology used to produce Hollow Core units.

Diversity, expertise and reliability.

Hollow Core products have many benefits, these include:

- Factory casting
- Reduced on-site labour
- Rapid construction
- Design flexibility
- Durability
- Long span, up to 17m
- Fire resistance
- Manufactured to Australian Standard AS 3600

A complete service

Hollow Core products can be designed, manufactured and installed by us, as a part of our commitment to providing an economical and total structural solution.

From the initial concept through to its design and installation, Hollow Core offers a complete service which can be tailored to meet specific structural requirements.



Above: The skeletal frame of this five level office development was constructed in just 55 days.



Left: The use of precast stair flights enable quick and safe access to buildings during construction.



Precast components installed in an office project at the Tally Ho Business Park.



Unusual or complicated details are achievable with precast components.



Hollow Core planks, along with precast columns, beams and panels provide open unpropped floors resulting in significant construction time savings.



Hollow Core planks are used for the economic construction of bridges.

An industry leader.

Hollow Core has proven to be a leader in its use of state-of-the-art technology in the manufacture of precast and prestressed concrete products.

We have demonstrated, in hundreds of projects, versatility, quality and confidence in using the most effective, safe and efficient method of construction.

This experience in delivering a total structural solution has distinct advantages in the construction of a wide variety of projects. A range of these include:

- Office Developments
- Apartments and Residences
- Major Shopping Centres
- Bridges
- Sporting Facilities
- Schools and Universities
- Churches
- Factories and Industrial Developments



Top: This multi storey car park development constructed using Hollow Core planks supported on a steel frame structure.

Left: The striking Heritage Country Club set in the Yarra Valley incorporates precast columns, beams, panels and Hollow Core floor planks.

Bottom Left: The full structural frame of this office development in Tally Ho Business Park has been constructed using precast components.

Bottom Right: The success of the Great Southern Stand saw Hollow Core contracted to supply the precast components for the Northern Stand re-development at the Melbourne Cricket Ground.

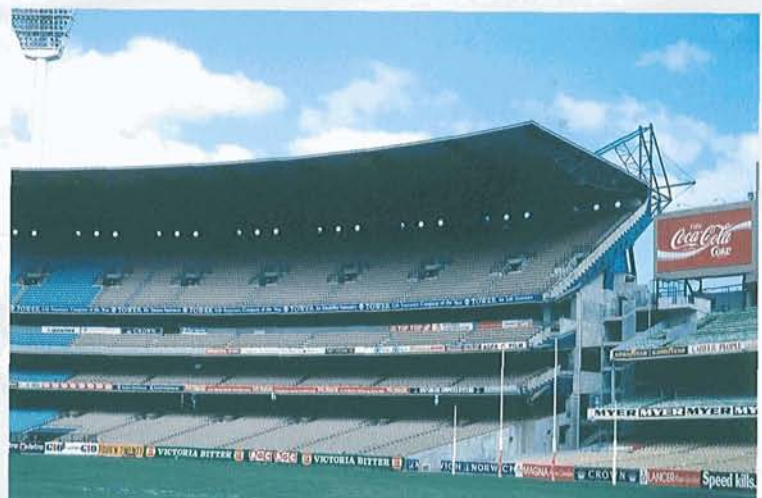

Hollow Core Concrete Detailing Manual

Contact Details

P.O. Box 241, Altona North, VIC 3025, Australia

12-14 Maria Street, Laverton North, VIC 3026, Australia

Tel: +61 3 9369 4944 Fax: +61 3 9369 2025

Email: info@hollowcore.com.au Web: www.hollowcore.com.au

Published Date: June 2004

Detailing Manual: Index

1.00

INDEX:

General Details

- 1.01 Hollow Core Plank Capacity
- 1.02 Guide Specification
- 1.03 Guide Specification (Cont.)
- 1.04 Screed Geometry
- 1.05 Screed Joint Details

Flooring Components

- 2.01 Hollow Core Floor Slab:
205 Thick 6 Core HC Slab
- 2.02 Hollow Core Floor Slab:
220 Thick 5 Core HC Slab
- 2.03 Hollow Core Floor Slab:
300 Thick 4 Core HC Slab
- 2.04 Hollow Core Floor Slab:
400 Thick 4 Core HC Slab
- 2.05 Hollow Core Floor Slab:
Typical Penetration Details
- 3.01 MiniSlab: 95 Thick MiniSlab
- 3.02 MiniSlab: 115 Thick MiniSlab
- 3.03 MiniSlab: 135 Thick MiniSlab

Precast Beams

- 4.01 Beam: 600 Wide PC Edge Beam
- 4.02 Beam: 600 Wide PC Edge Beam

Precast Beams (Cont.)

- 4.03 Beam: 700 Wide PC Internal Beam
- 4.04 Beam: 700 Wide PC Internal Beam
- 4.05 Beam: 900 Wide PC Internal Beam
- 4.06 Beam: 900 Wide PC Internal Beam
- 4.07 Beam: 1200 Wide PC Internal Beam
- 4.08 Beam: 1200 Wide PC Internal Beam

Precast Stairs

- 5.01 Precast Stair Details
- 5.02 Precast Stair Details: Typical Footing Detail
- 5.03 Precast Stair Details: Hollow Core Connection
- 5.04 Precast Stair Details: Wall Panel Connection

Connection Details

- 6.01 Beam to Hollow Core Connection
- 6.02 Beam to Column Connection
(incl. Hollow Core)
- 6.03 Edge Beam to Hollow Core Connection
- 6.04 Precast Wall to Hollow Core Connection
- 6.05 Precast Wall to Hollow Core Connection
- 6.06 Steel Trimmer Beam Detail
- 6.07 Hollow Core to Steel Beam Connection: Internal
- 6.08 Hollow Core to Steel Beam Connection: Edge Beam
- 6.09 Column Base Detail

Hollow Core Plank Capacity

1.01

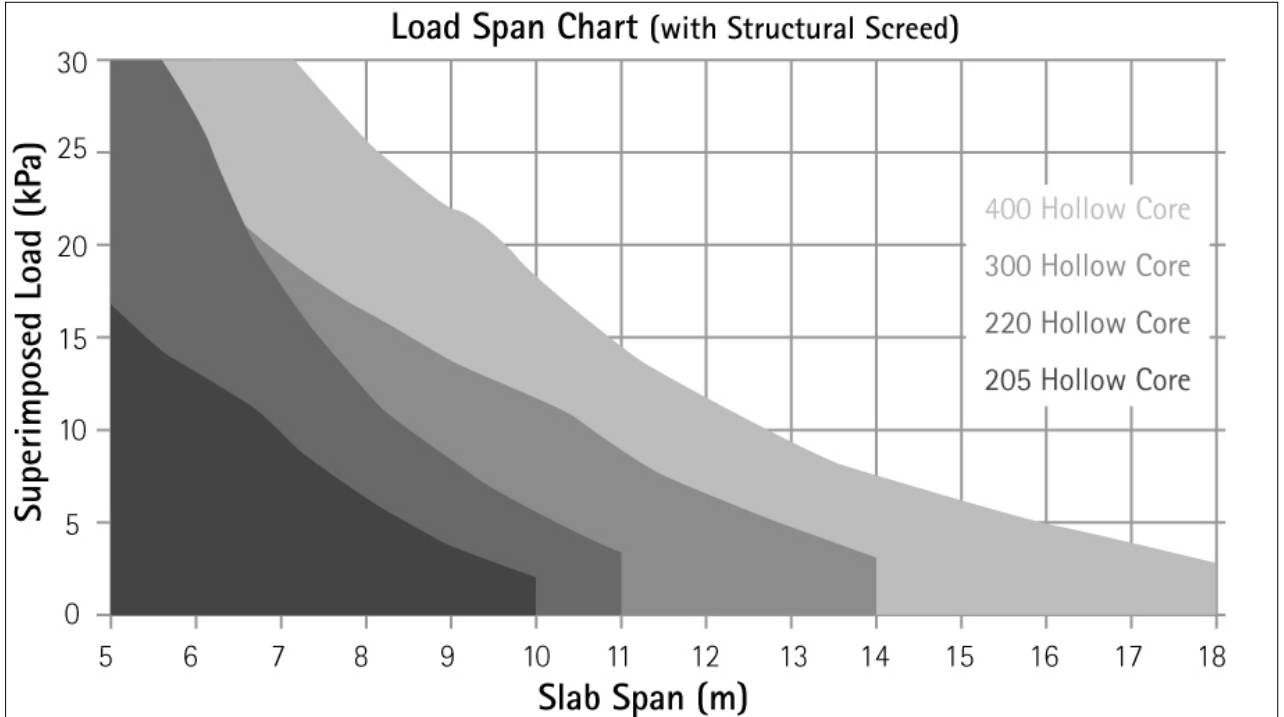

205 Thick Hollow Core

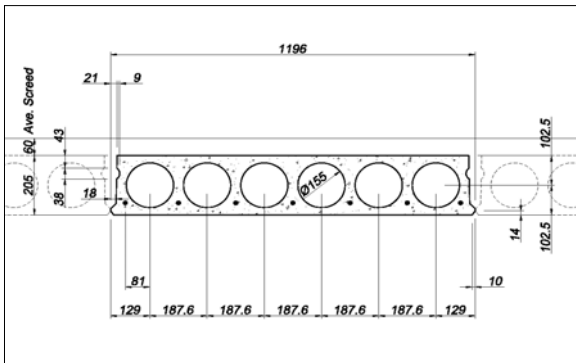

220 Thick Hollow Core

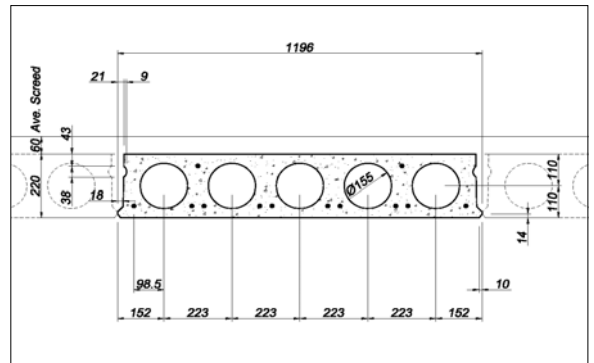

300 Thick Hollow Core

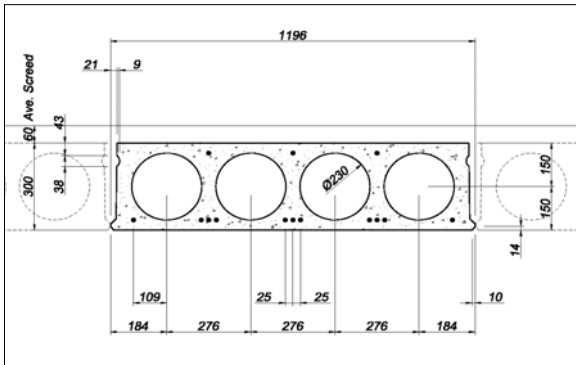

400 Thick Hollow Core

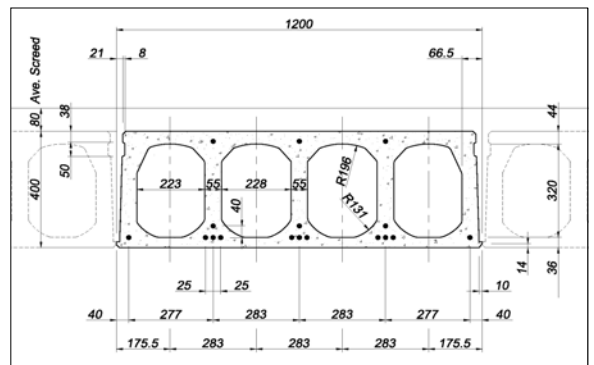

These tables are for guidance purposes only. Where deflections, point and/or line loading, vibration etc. require consideration please contact our technical department. These charts allow for self weight and screed, but do not allow for any finishes, partitions or the effect of any penetrations to the planks.

Hollow Core Guide Specification

1.02

This guide is intended to be used in the preparation of the project specification. It should be checked for compatibility with the particular project requirements by deleting any provisions that do not apply and adding special provisions as required.

DESIGN

Planks shall be designed in accordance with AS 3600 and appropriate international standards, except where industry practice provides a proven alternative method.

The manufacturer shall prepare and submit shop drawings for approval of the general arrangement of the planks, adequacy and dimensions prior to manufacture. Shop drawings detailing each unit, cast-in inserts and its strand configuration shall be submitted to the building contractor for approval.

The design of the structure to support the Hollow Core planks shall be the responsibility of the Structural Engineer for the project unless designed by Hollow Core Concrete Pty. Ltd. The Hollow Core planks shall be designed and certified by the product manufacturer.

MATERIALS

Cement shall comply with AS 3972 and supplementary cementitious materials with AS 3582 parts 1 and 2. Aggregates shall comply with AS 2758.1. Chemical admixtures shall comply with AS 1478.1.

Prestressing steel shall be stress-relieved low-relaxation strand complying with AS 1311. Strand shall be clean and free of deleterious substances at the time of casting.

Concrete shall have a minimum characteristic 28-day strength of 50MPa and shall conform to the requirements of AS 3600. Concrete strength at release of prestress shall be a minimum of 25MPa or as required by the structural design.

Topping concrete shall have a minimum characteristic 28-day strength of 32MPa and be reinforced with a minimum SL72 mesh or as shown on the drawings. If topping concrete is used to grout the keyways, the maximum aggregate size shall be 10mm.

MANUFACTURE

Hollow Core floor planks shall be cast on a long-line bed by an approved machine and mechanically compacted. The top surface shall be finished as cast by the machine or intentionally-roughened to achieve the specified bond characteristics of the topping or other finish applied after erection.

TOLERANCES

Floor planks shall be supplied in accordance with the following tolerances.

Length	+10mm	-10mm
Width	+3mm	-6mm
Thickness	+3mm	-3mm
Squareness of end	+6mm	-6mm
Bow / Wind	10mm per 3000mm	
Location of inserts	+20mm	-20mm
Cover to strand	+3mm	-3mm
Differential Camber adjacent units	2mm/m span but not greater than 15mm	

Hollow Core Guide Specification

1.03

DELIVERY AND HANDLING

Hollow Core floor planks shall be lifted and supported during manufacture, storage, transport and erection operations at the lifting positions nominated by the product manufacturer only.

The on site lifting and erection operations shall be in accordance with a site specific 'Work Method Statement' produced by the erection contractor in association with product manufacturer. The 'Work Method Statement' shall be in accordance with the appropriate Industry Standard.

ERECTION

The building contractor shall be responsible for providing true and level bearing surfaces for the support of the Hollow Core planks. Temporary shoring and bracing shall also be provided as necessary to ensure the stability of the structure during erection. The Hollow Core planks shall be installed by a competent erection contractor. Where the manufacturer also erects the planks, the building Contractor shall be responsible for providing suitable access at the site to enable trucks and cranes to operate under their own power.

Bearing strips shall be accurately set where required. Any reinforcement required shall be placed as detailed on the drawings. Keyways shall be filled and compacted with a 3:1 sand-cement grout mix or by the topping concrete using a maximum aggregate size of 10mm. Voids at plank ends shall be sealed to prevent penetration of topping into the cores by more than 50mm. End filling should not be more than the support length unless detailed by the product manufacturer.

ATTACHMENTS AND PENETRATIONS

Attachments and fixings to the Hollow Core planks shall be in accordance with the approved details only and shall not impair or reduce the strength of the floor planks.

Penetrations and chases to the Hollow Core planks shall be in accordance with details agreed by the Structural Engineer and the product manufacturer.

IN-SITU TOPPING

The Building Contractor shall provide a well-compacted in-situ structural concrete topping to the floor planks as detailed on the drawings. Reinforcement is to be placed in accordance with structural details. The plank surface shall be clean and free of loose material and surface-moist (saturated surface-dry) immediately prior to placing the topping. Finishing and curing of the topping should ensure that plastic shrinkage cracks are controlled to acceptable levels. Construction joints in the topping shall be located as shown on the drawings.

INSPECTION AND ACCEPTANCE

The manufacturer shall provide access to its production facilities for inspection of work in progress by the Structural Engineer and/or the building contractor to verify conformity of the product to the project specifications.

Screed Geometry

1.04

Allowance for Camber

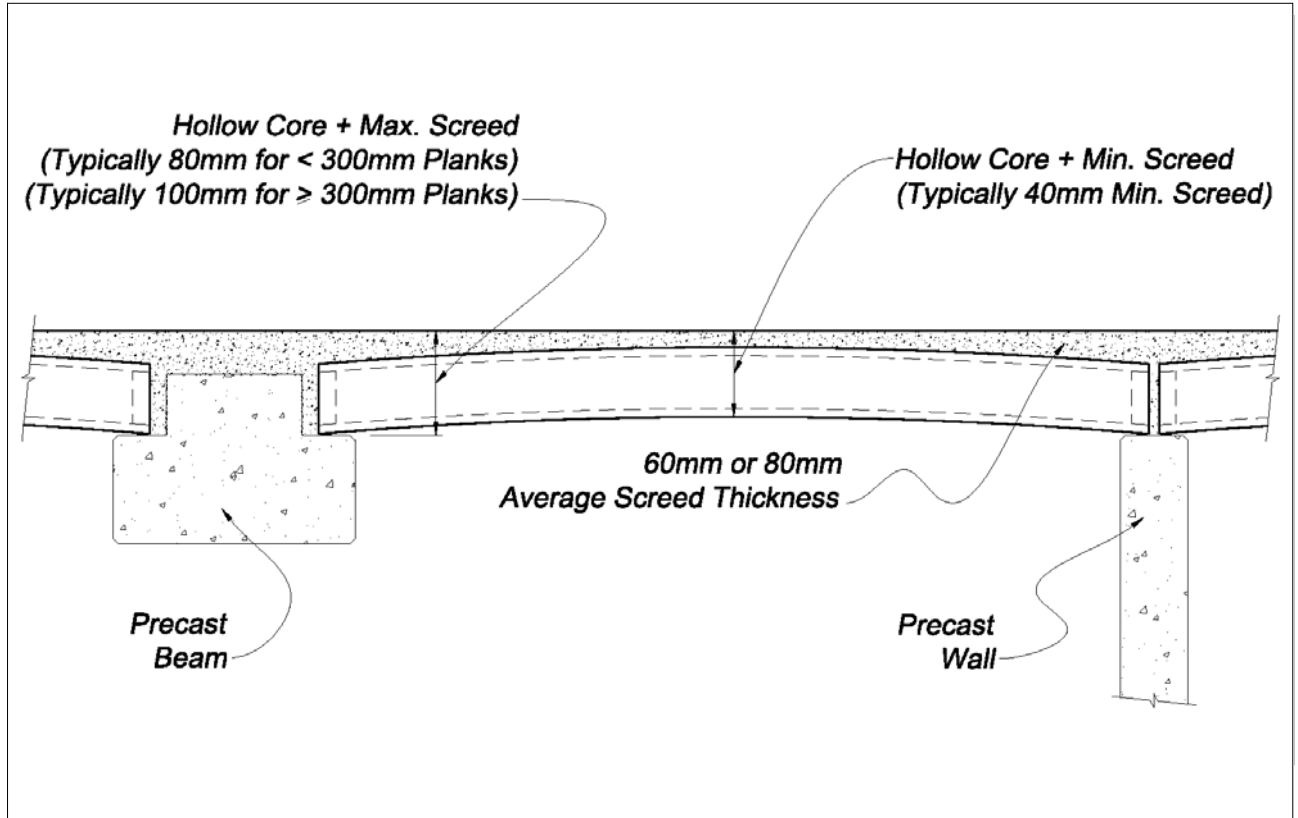

Hollow Core floor planks are cambered because of the upward bending induced by prestressing. This camber should be allowed for in detailing the planks and the joints at abutting walls, door openings and the like. A site-cast topping screed unifies the planks into a monolithic floor, takes out differential levels between units and provides a level working surface. The minimum thickness of topping occurs at the highest point of the plank. For practical purposes, 60mm average topping is used for 200 - 220 deep units and 80mm for 300mm deep units and above. Typically a minimum SL72 mesh is nominated as the screed reinforcement. Screed concrete should be a low shrinkage mix and if necessary superplasticised to facilitate placing, if the topping concrete is to be used to grout the keyways, the maximum aggregate size be 10mm.

Screed Joint Details

1.05

Construction Joint

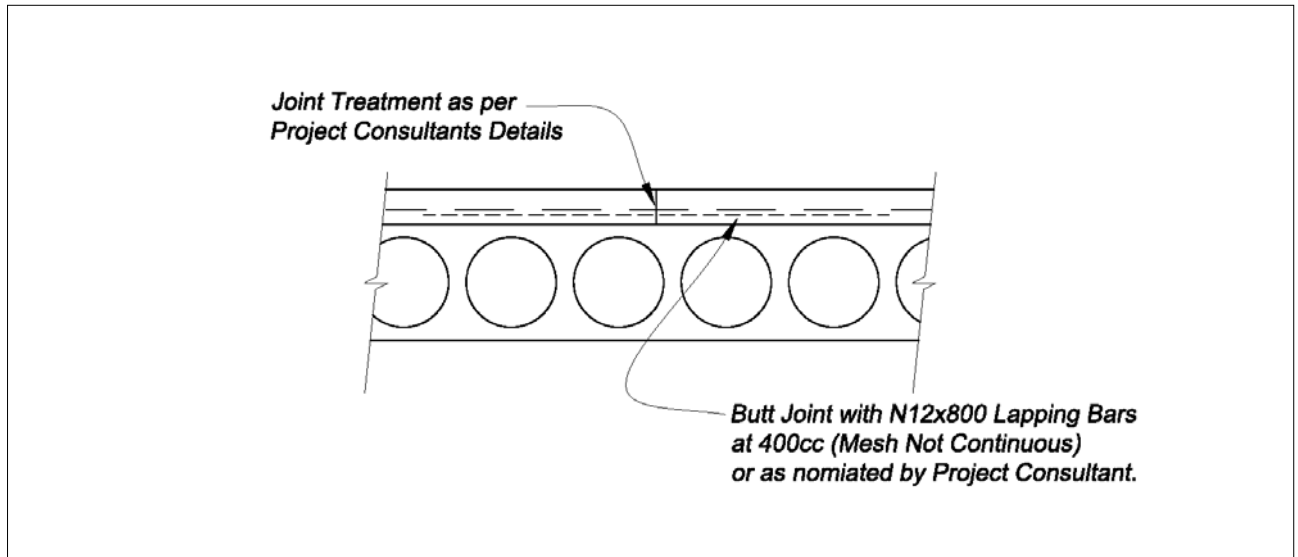

Control Joint

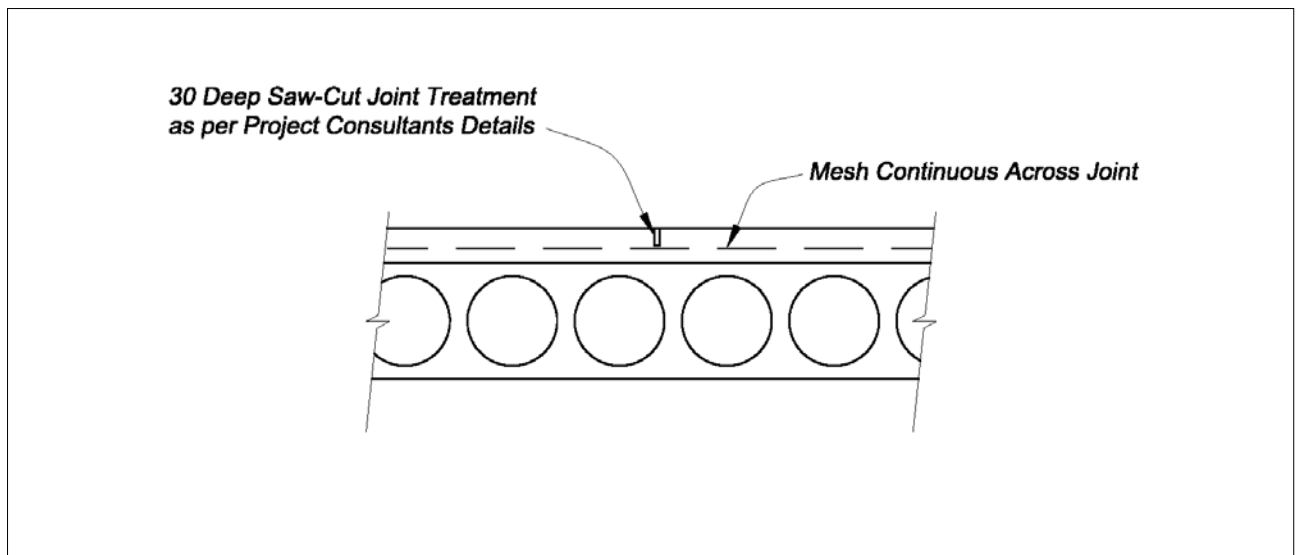

The project documentation should indicate the location of both the construction and control joints, however, joints should typically be at 8.4m maximum centers in both directions. Where joints are saw-cut the cut should be made within 18 hours of casting the topping screed.

These diagrams are for guidance purposes only. Please contact our Technical department for specific project and/or component requirements

205 Thick 6 Core HC Slab 2.01

Load Span Chart (with Structural Screed)

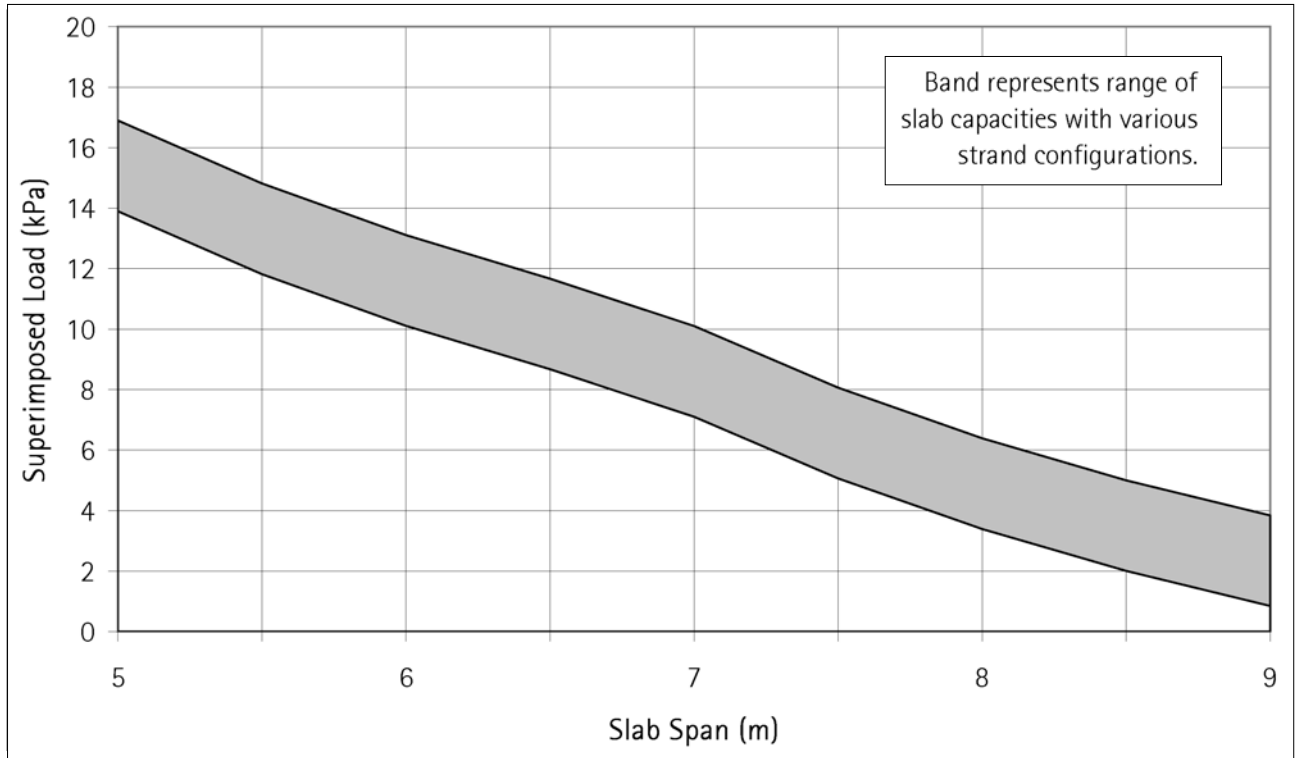

Slab Code	F205.6
Design Width	1200mm
Number of Top Strands	0 - 5
Number of Bottom Strands	4 - 7
Prestress (12.7 ϕ)	500 - 1000MPa
Concrete Grade	50MPa
Cover to Strand	35mm
Fire Rating	1½-3 hrs
Cross Sectional Area	124.5x10 ³ mm ²
Self Weight	260 kg/m ²
Self Weight (incl. Screed)	426 kg/m ²

Cross Section

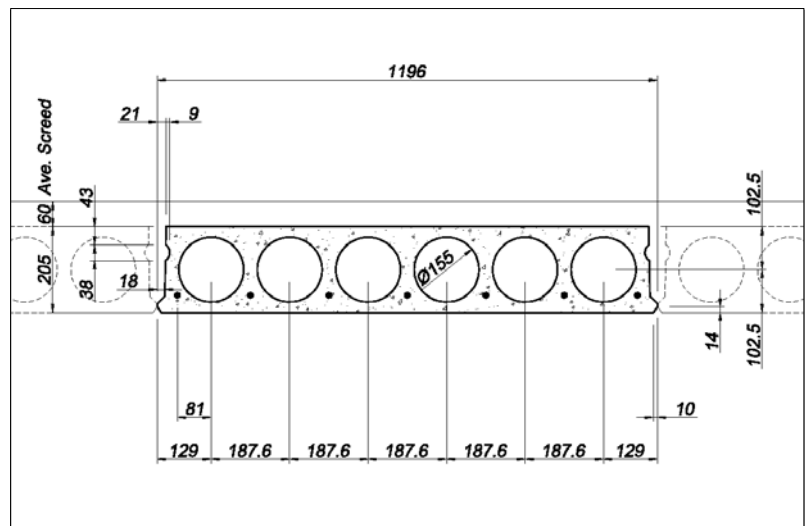

These tables are for guidance purposes only. Where deflections, point and/or line loading, vibration etc. require consideration please contact our technical department. These charts allow for self weight and screed, but do not allow for any finishes, partitions or the effect of any penetrations to the planks.

220 Thick 5 Core HC Slab 2.02

Load Span Chart (with Structural Screed)

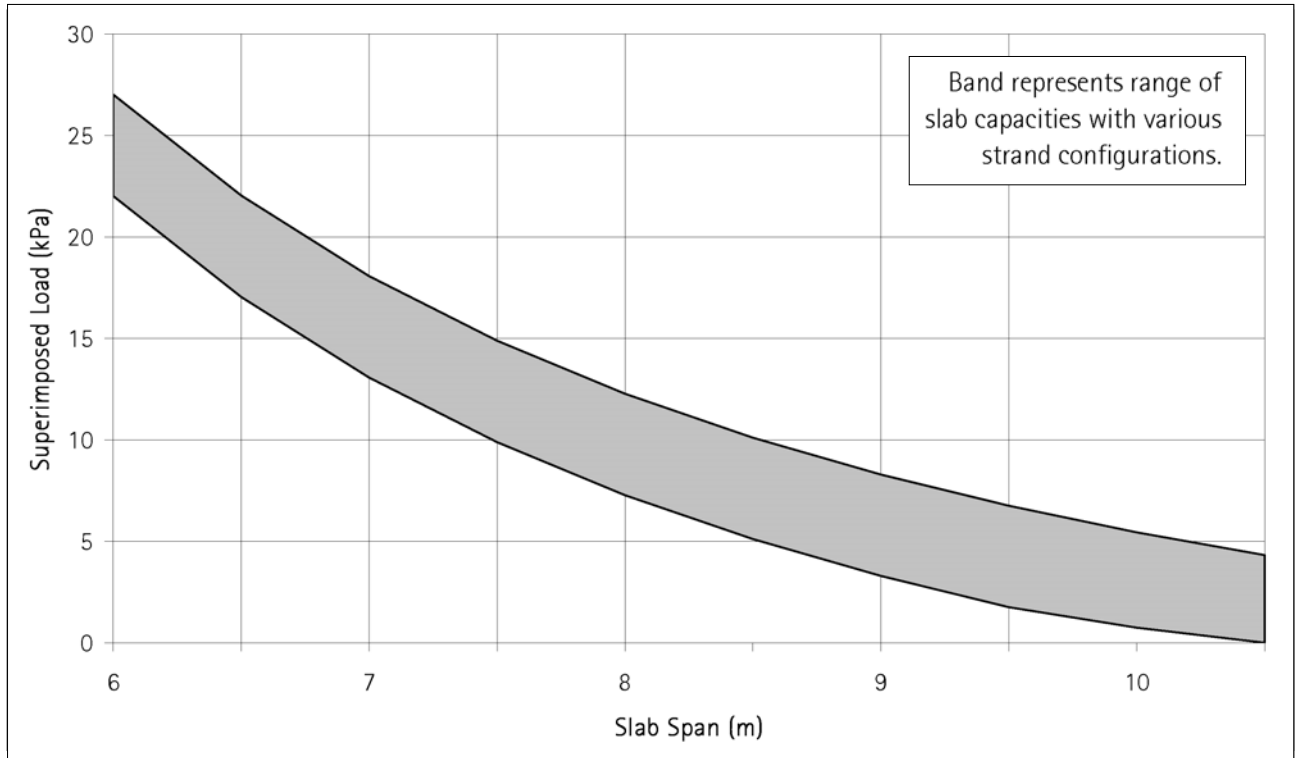

Cross Section

Slab Code	F220.5
Design Width	1200mm
Number of Top Strands	0 - 4
Number of Bottom Strands	6 - 10
Prestress (12.7 ϕ)	500 - 1200MPa
Concrete Grade	50MPa
Cover to Strand	35-45mm
Fire Rating	1½-4 hrs
Cross Sectional Area	160.7x10 ³ mm ²
Self Weight	336 kg/m ²
Self Weight (incl. Screed)	503 kg/m ²

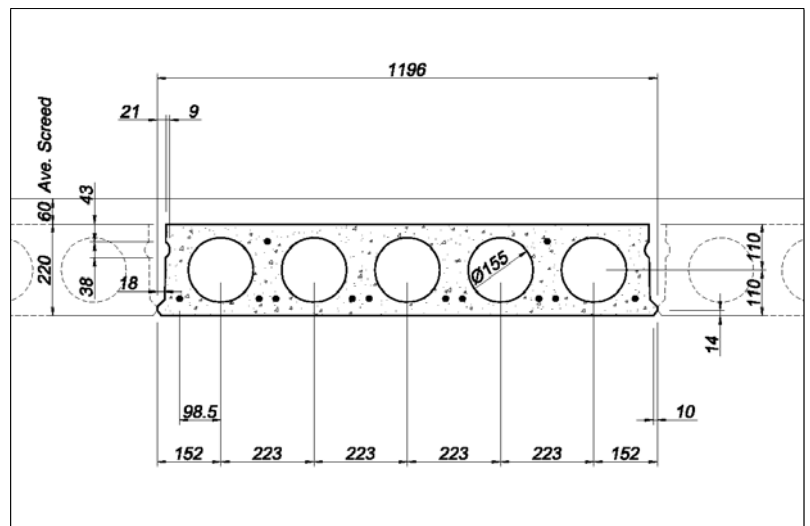

These tables are for guidance purposes only. Where deflections, point and/or line loading, vibration etc. require consideration please contact our technical department. These charts allow for self weight and screed, but do not allow for any finishes, partitions or the effect of any penetrations to the planks.

300 Thick 4 Core HC Slab 2.03

Load Span Chart (with Structural Screed)

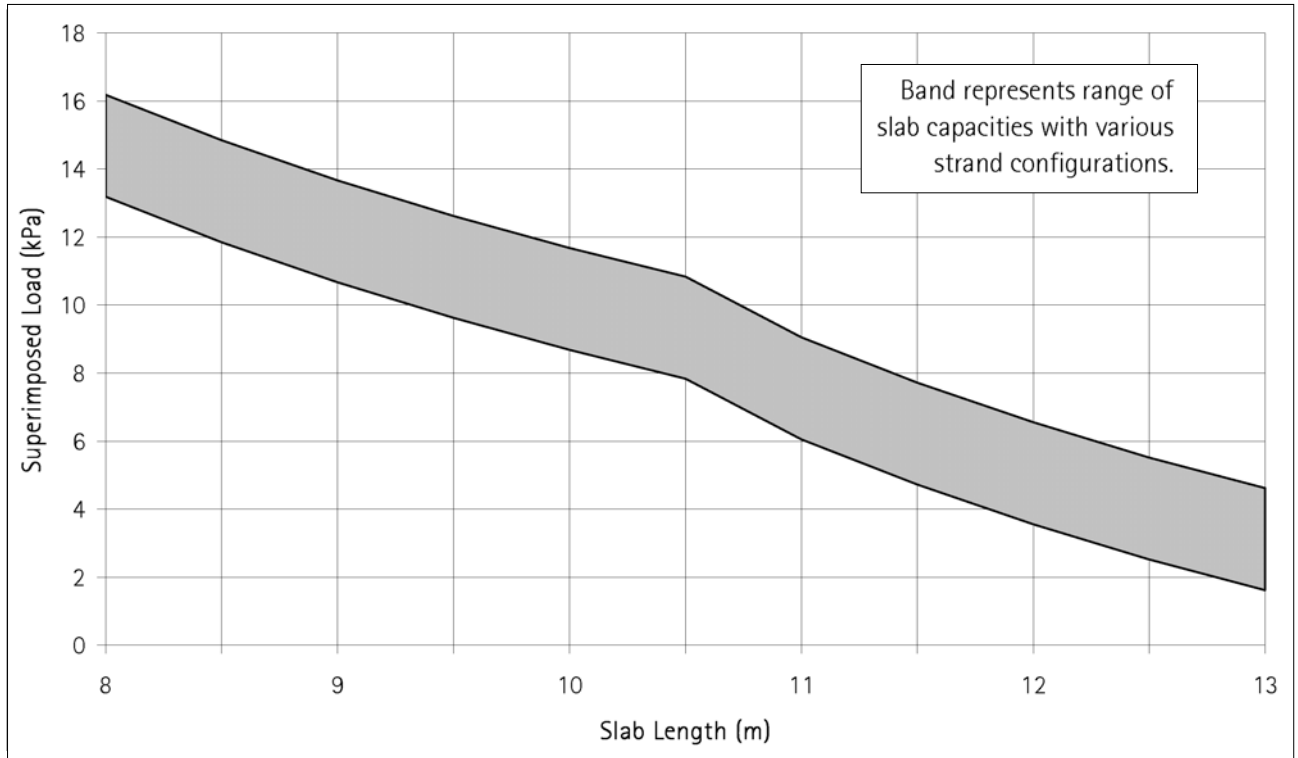

Cross Section

Slab Code	F300.4
Design Width	1200mm
Number of Top Strands	0 - 3
Number of Bottom Strands	5 - 11
Prestress (12.7Ø)	500 - 1200MPa
Concrete Grade	50MPa
Cover to Strand	35-45mm
Fire Rating	1½-4 hrs
Cross Sectional Area	181.5x10 ³ mm ²
Self Weight	380 kg/m ²
Self Weight (incl. Screed)	554 kg/m ²

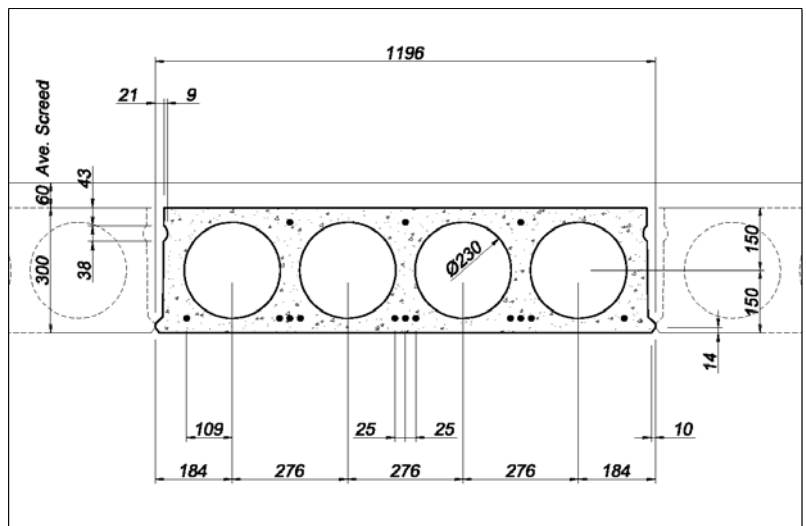

These tables are for guidance purposes only. Where deflections, point and/or line loading, vibration etc. require consideration please contact our technical department. These charts allow for self weight and screed, but do not allow for any finishes, partitions or the effect of any penetrations to the planks.

400 Thick 4 Core HC Slab 2.04

Load Span Chart (with Structural Screed)

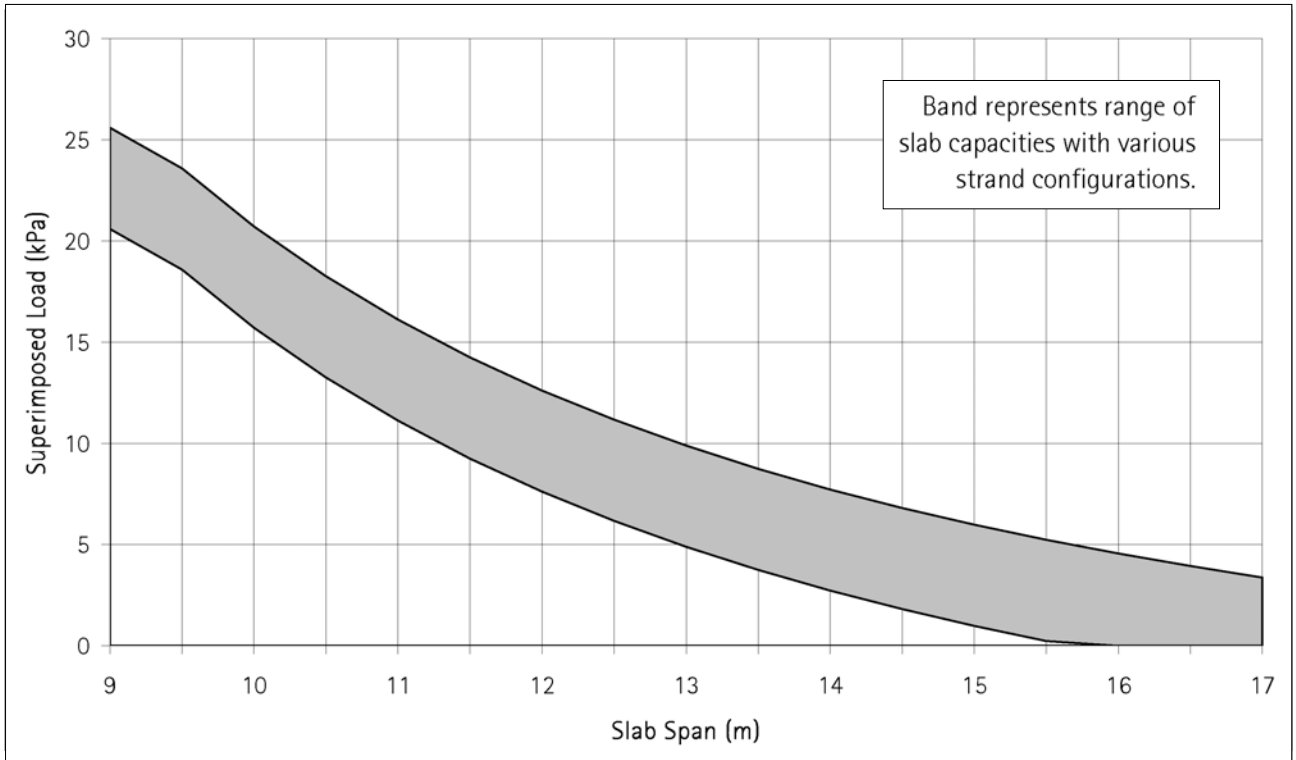

Cross Section

Slab Code	F400.4
Design Width	1200mm
Number of Top Strands	0 - 3
Number of Bottom Strands	5 - 14
Prestress (12.7Ø)	500 - 1200MPa
Concrete Grade	50MPa
Cover to Strand	35-40mm
Fire Rating	1½-3 hrs
Cross Sectional Area	207.3x10 ³ mm ²
Self Weight	433 kg/m ²
Self Weight (incl. Screed)	633 kg/m ²

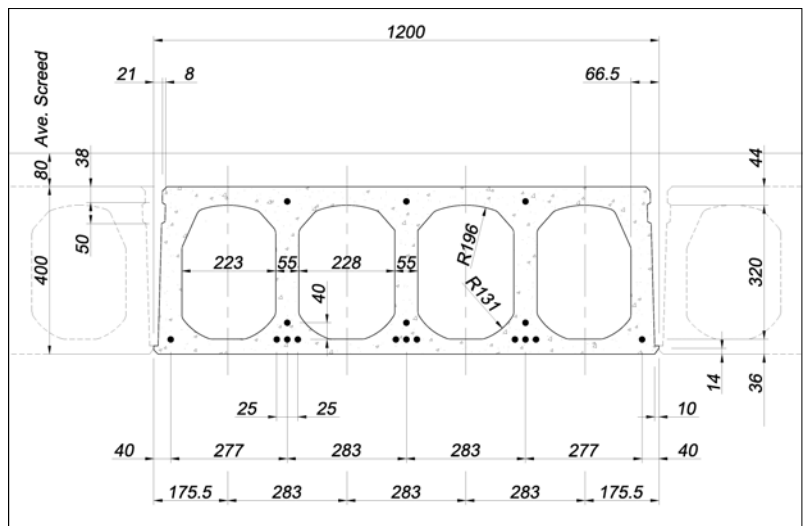

These tables are for guidance purposes only. Where deflections, point and/or line loading, vibration etc. require consideration please contact our technical department. These charts allow for self weight and screed, but do not allow for any finishes, partitions or the effect of any penetrations to the planks.

Hollow Core Typical Penetration Details

2.05

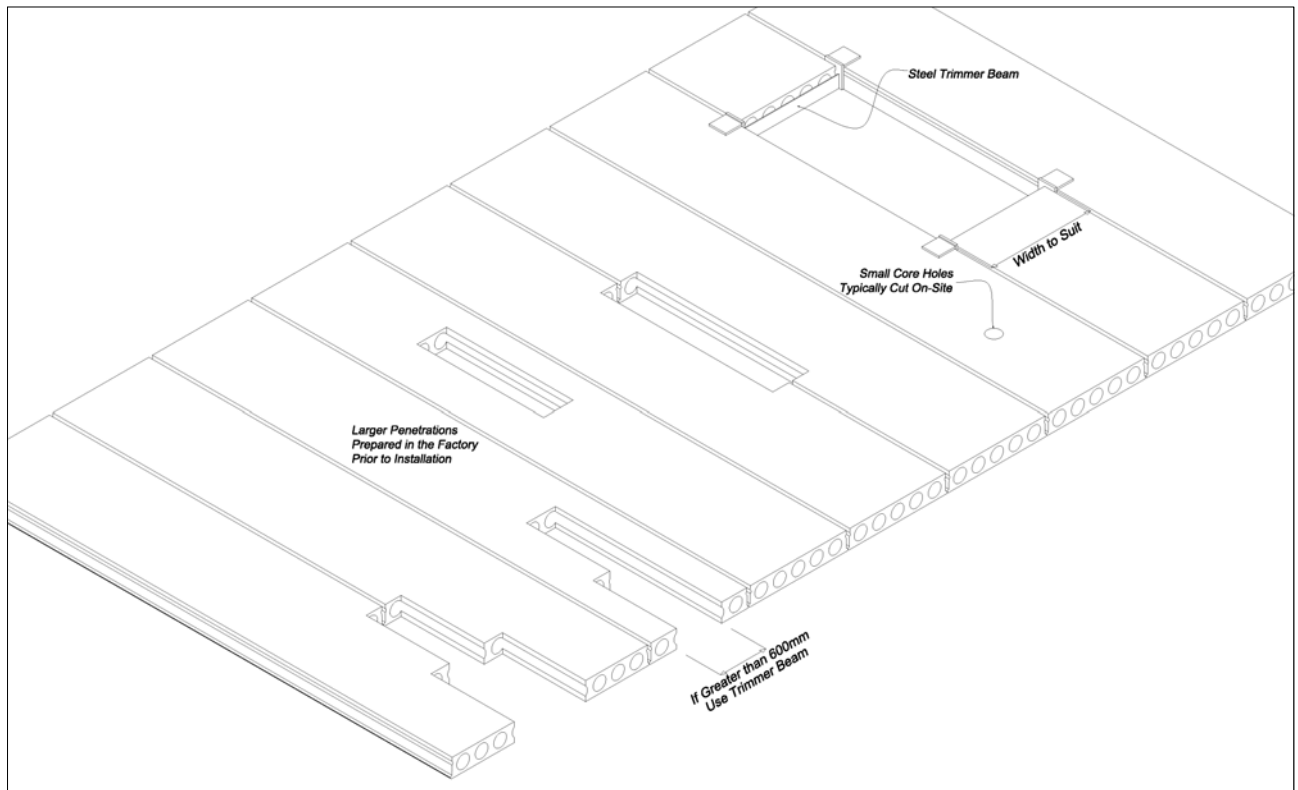

The Hollow Core flooring system allows for significant flexibility in terms of penetrations and block-outs. Penetrations for plumbing, electrical and mechanical services can be catered for along with larger voids such as stair openings and light wells. There are a number of different ways that these can be achieved. Examples of these are shown on the above drawing and can be described as follows:

1. Core Holes:

Core holes are the most common type of penetration and are easily achieved by simply drilling the required hole on site to suit the building requirements. Provided the core holes are not greater than 120mm \varnothing (for 205 and 220mm thick slabs) and 165mm \varnothing (for 300 and 400mm thick slabs) they can be easily catered for by simply drilling through core. In broad terms up to 65% of the slab section has the allowance to be cored through without any significant structural effects. Where the penetration is greater than that nominated above or if the hole cuts through the web and strand the slab manufacturer should be contacted to review the slab.

2. Cut-Outs:

Larger penetrations, such as those required for mechanical services can be easily catered for as shown on the above drawing. These larger cut-outs are nominated during the design process to allow the design to take into account the local strand and web reduction. These cut-outs are generally pre-cut in the factory prior to installation. If future demands or site modifications require these larger penetrations to be introduced, they can be catered for in most cases with minor on-site slab modification.

3. Trimmer Beams:

Large openings to allow for stair voids, light wells or larger mechanical services can be catered for by the use of trimmer beams. Where these large penetrations are required full width headers or trimmer beams are used to transfer the load to the adjacent planks. These planks are designed to support the additional load without the need for supporting columns.

The slab manufacturer should be consulted during the preliminary stages of the project so that advice can be provided on the most cost effective and practical design to accommodate the required penetrations.

95 Thick MiniSlab 3.01

Load Span Chart (with Structural Screed)

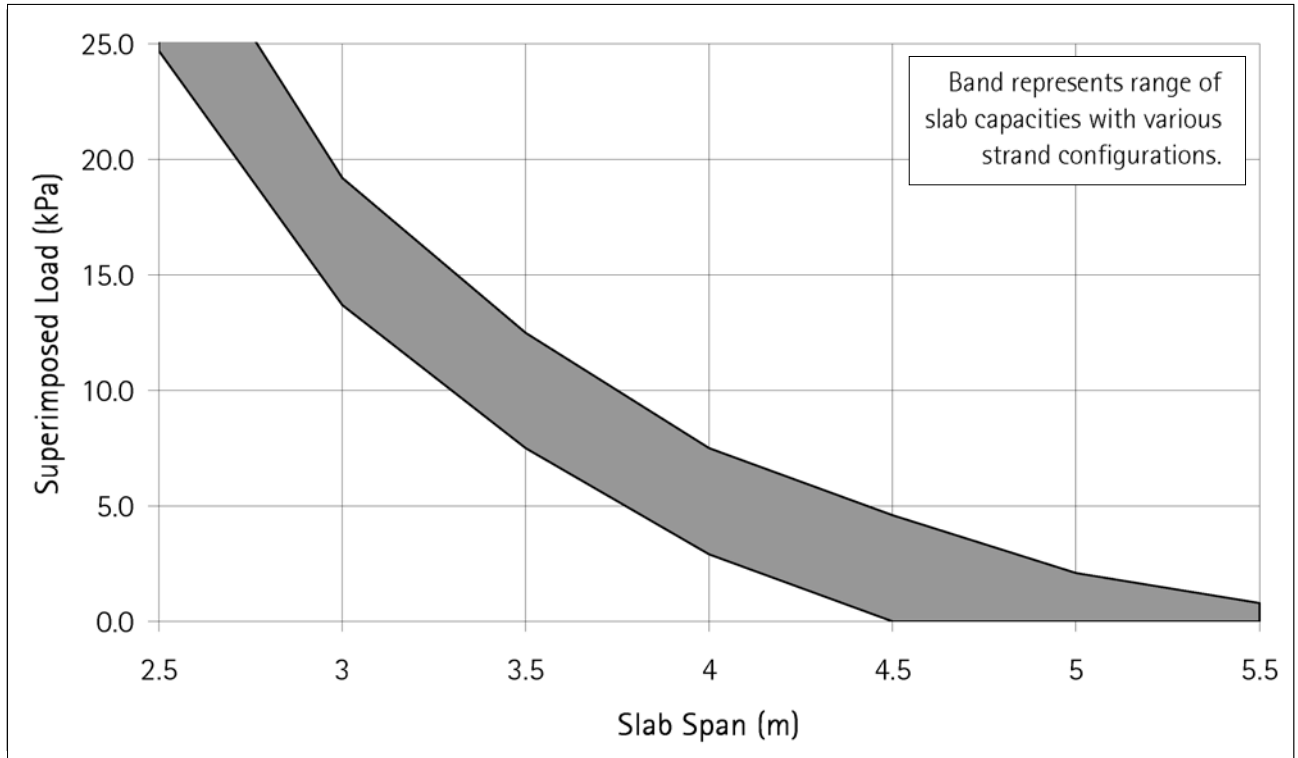

Cross Section

Slab Code	MS95
Design Width	1200mm
Number of Bottom Strands	4 - 6
Prestress (12.7Ø)	500 - 1000MPa
Concrete Grade	50MPa
Cover to Strand	25-40mm
Fire Rating	1-3 hrs
Cross Sectional Area	111.1x10 ³ mm ²
Self Weight	232 kg/m ²
Self Weight (incl. Screed)	370 kg/m ²

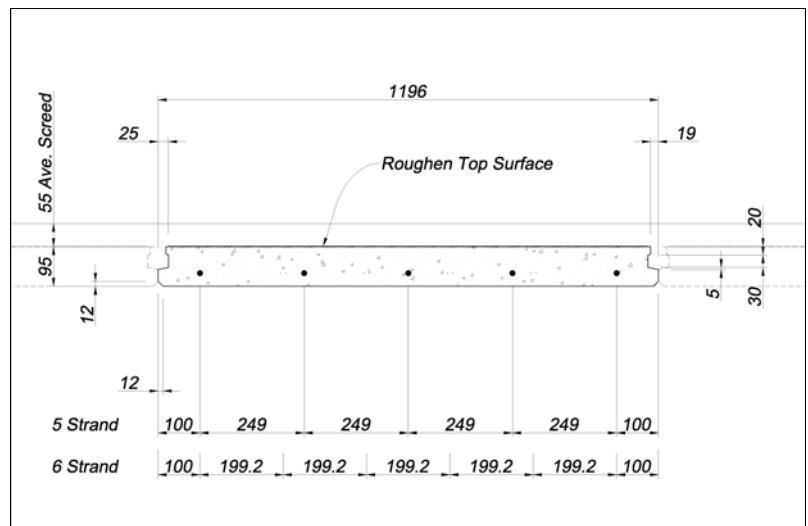

These tables are for guidance purposes only. Where deflections, point and/or line loading, vibration etc. require consideration please contact our technical department. These charts allow for self weight and screed, but do not allow for any finishes, partitions or the effect of any penetrations to the planks.

115 Thick MiniSlab 3.02

Load Span Chart (with Structural Screed)

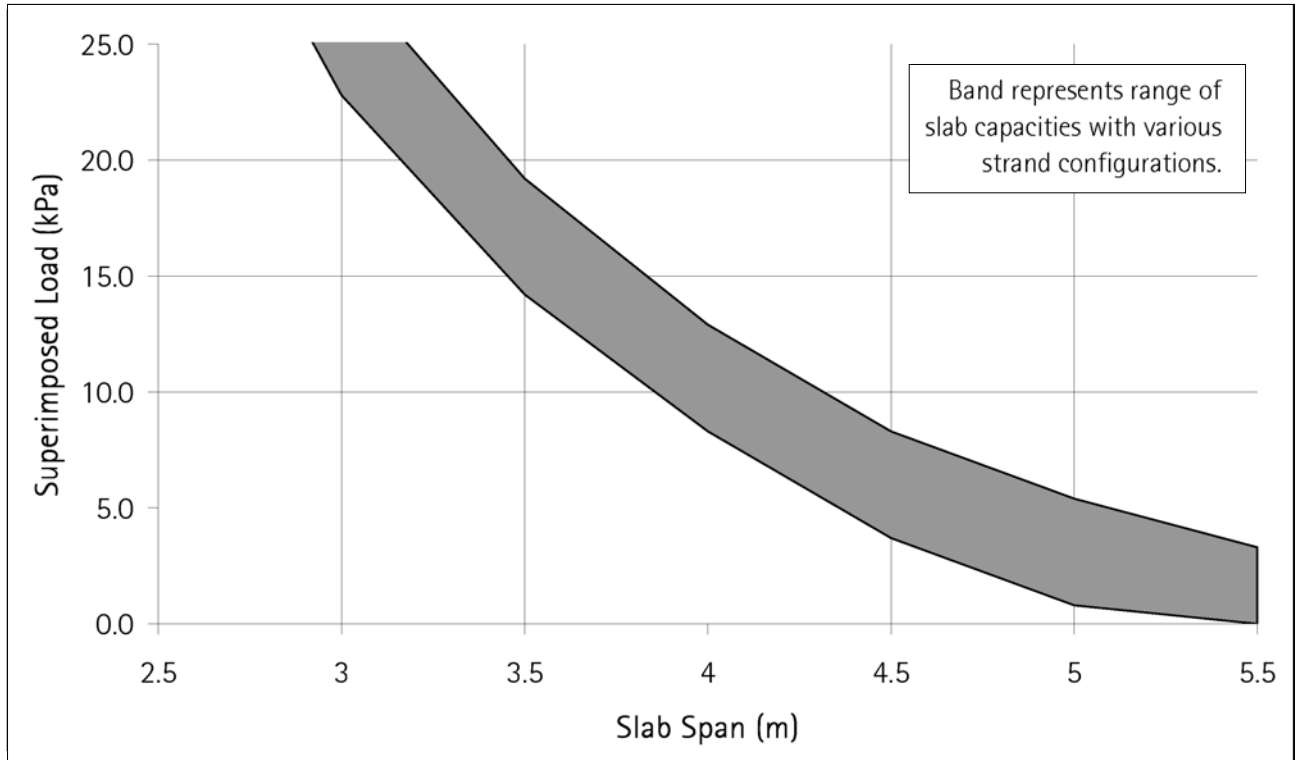

Cross Section

Slab Code	MS115
Design Width	1200mm
Number of Bottom Strands	4 - 6
Prestress (12.7Ø)	500 - 1100MPa
Concrete Grade	50MPa
Cover to Strand	25-45mm
Fire Rating	1-4 hrs
Cross Sectional Area	134.2x10 ³ mm ²
Self Weight	281 kg/m ²
Self Weight (incl. Screed)	419 kg/m ²

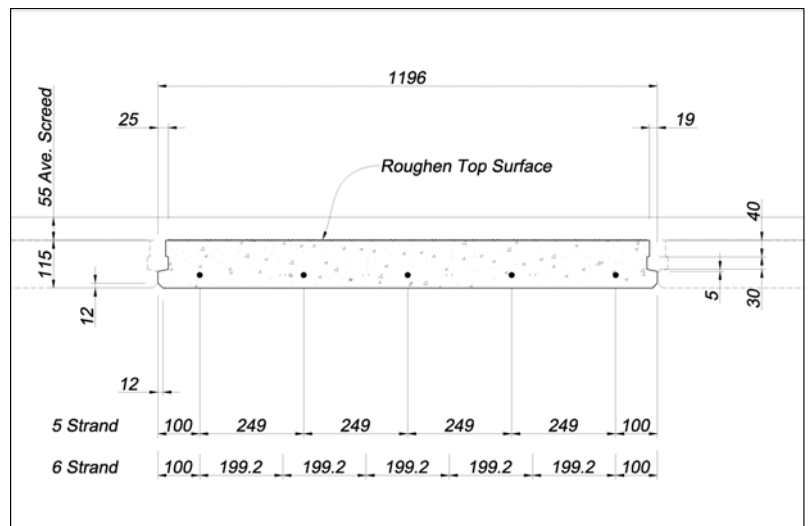

These tables are for guidance purposes only. Where deflections, point and/or line loading, vibration etc. require consideration please contact our technical department. These charts allow for self weight and screed, but do not allow for any finishes, partitions or the effect of any penetrations to the planks.

135 Thick MiniSlab 3.03

Load Span Chart (with Structural Screed)

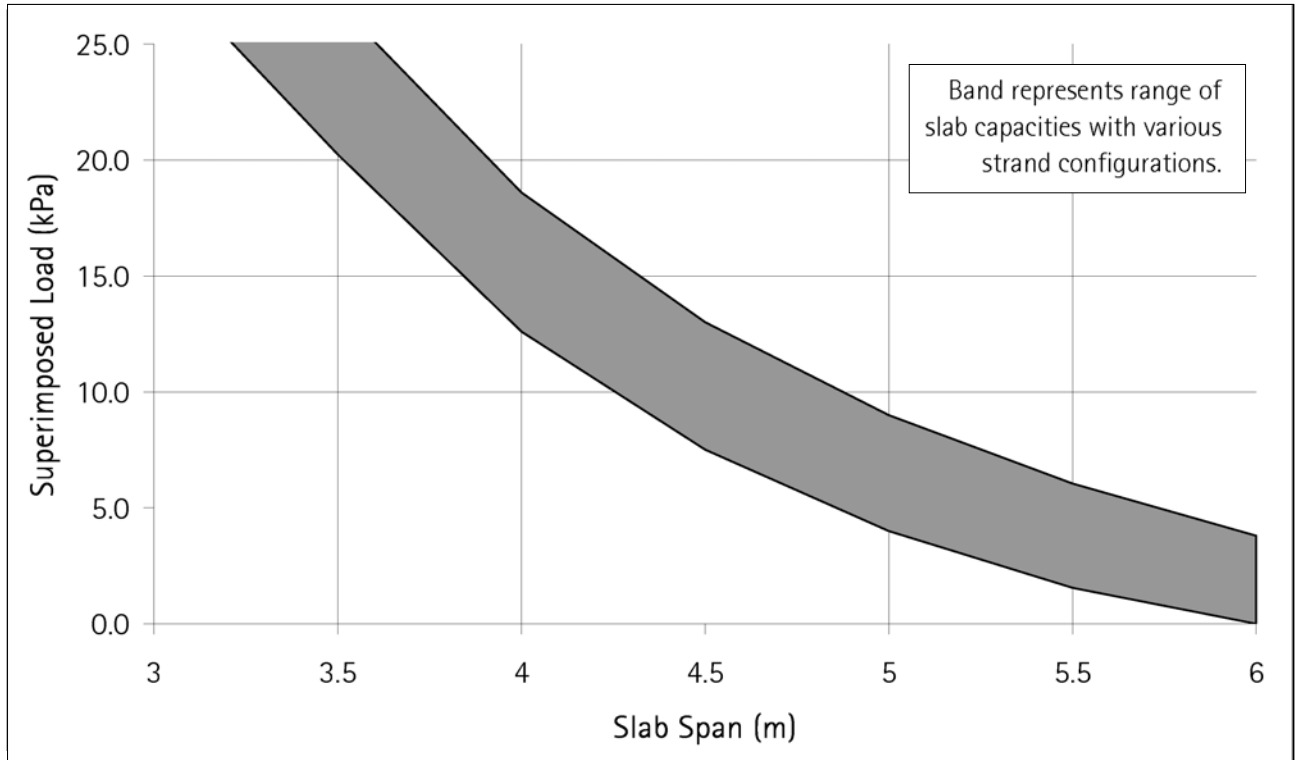

Cross Section

Slab Code	MS135
Design Width	1200mm
Number of Bottom Strands	4 - 7
Prestress (12.7Ø)	500 - 1100MPa
Concrete Grade	50MPa
Cover to Strand	25-45mm
Fire Rating	1-4 hrs
Cross Sectional Area	158.1x10 ³ mm ²
Self Weight	331 kg/m ²
Self Weight (incl. Screed)	469 kg/m ²

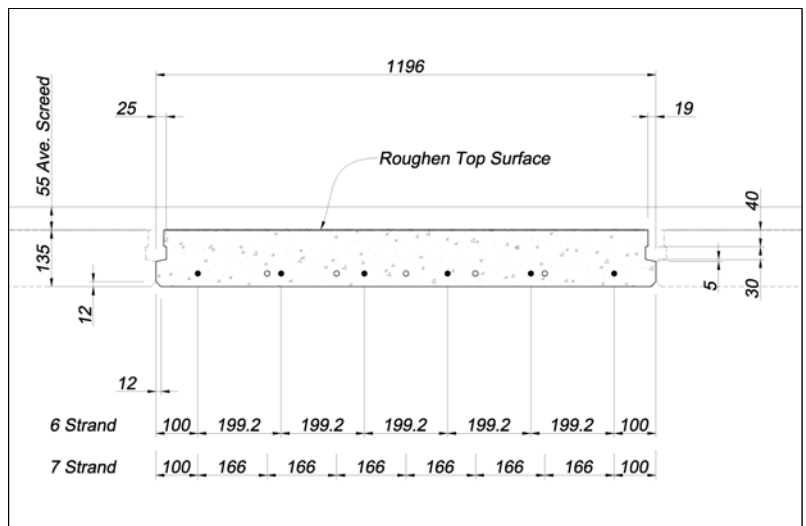

These tables are for guidance purposes only. Where deflections, point and/or line loading, vibration etc. require consideration please contact our technical department. These charts allow for self weight and screed, but do not allow for any finishes, partitions or the effect of any penetrations to the planks.

600 Wide PC Edge Beam

4.01

Load Span Chart

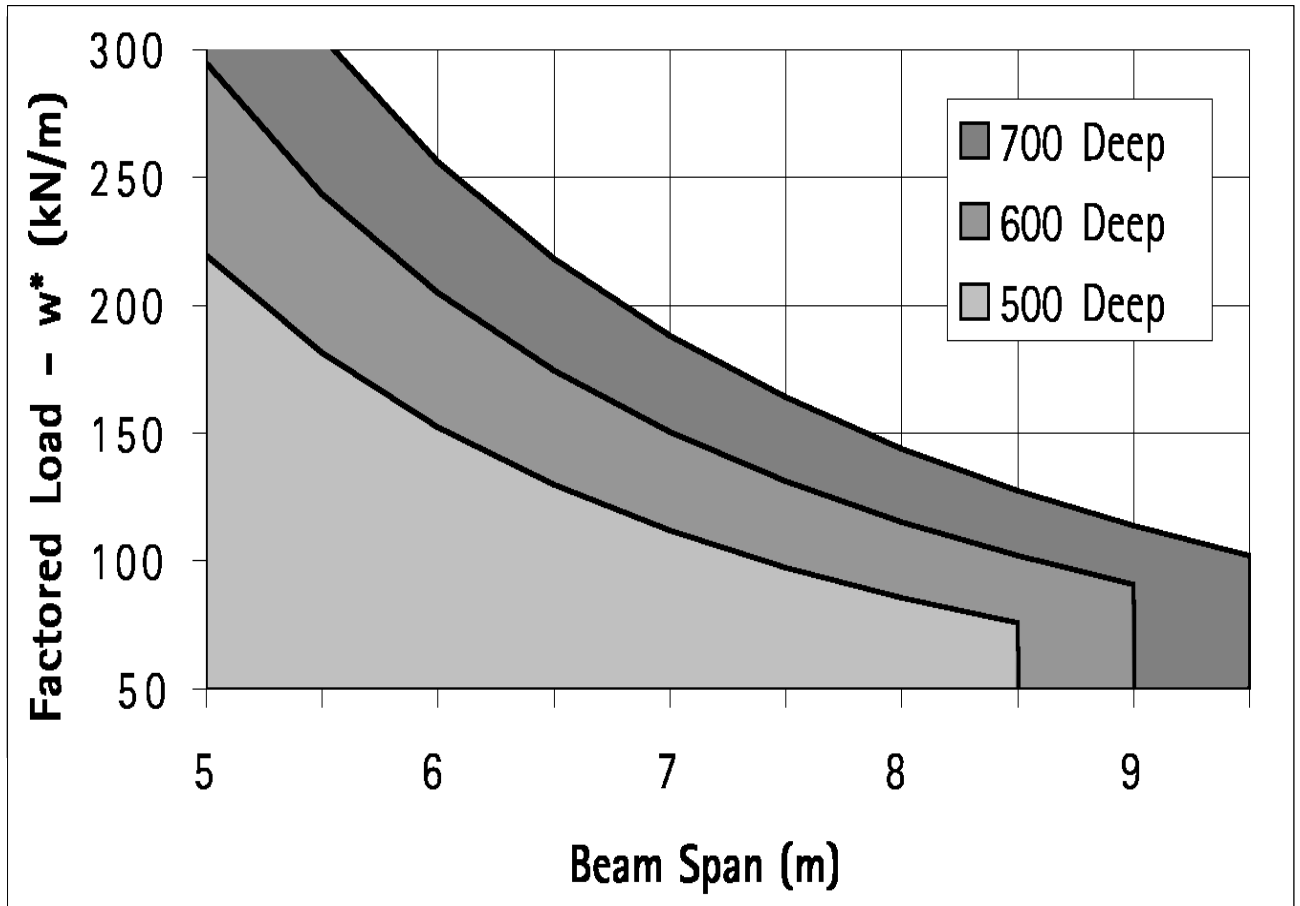

Band represents the range of beam capacities available with various strand and reinforcement configurations.

These tables are for guidance purposes only. Where deflections, point and/or line loading, vibration etc. require consideration please contact our technical department.

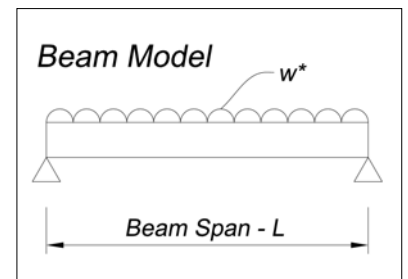

600 Wide PC Edge Beam

4.02

Beam Code	PCB6.500
Design Width	600mm
Number of Bottom Strands	6 - 12
Prestressing Strand	12.7 \varnothing
Concrete Grade	50MPa
Fire Rating	1½-4 hrs
Cross Sectional Area	256.8x10 ³ mm ²
Self Weight	642 kg/m

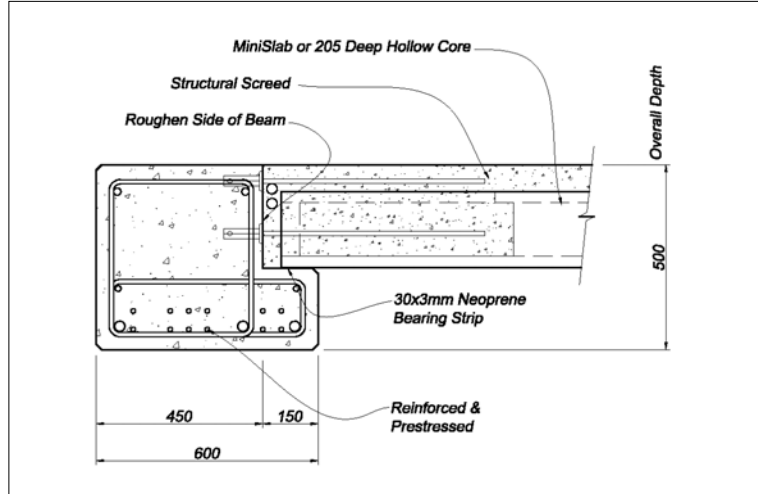

Beam Code	PCB6.600
Design Width	600mm
Number of Bottom Strands	6 - 12
Prestressing Strand	12.7 \varnothing
Concrete Grade	50MPa
Fire Rating	1½-4 hrs
Cross Sectional Area	302.6x10 ³ mm ²
Self Weight	756 kg/m

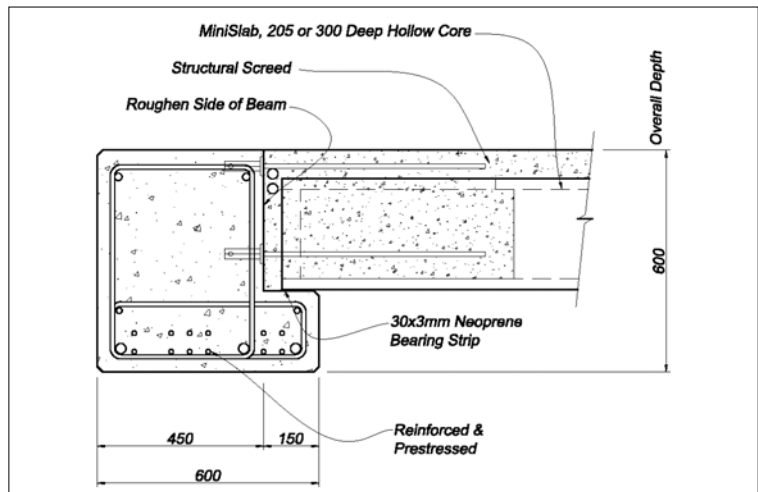

Beam Code	PCB6.700
Design Width	600mm
Number of Bottom Strands	6 - 12
Prestressing Strand	12.7 \varnothing
Concrete Grade	50MPa
Fire Rating	1½-4 hrs
Cross Sectional Area	344.6x10 ³ mm ²
Self Weight	861 kg/m

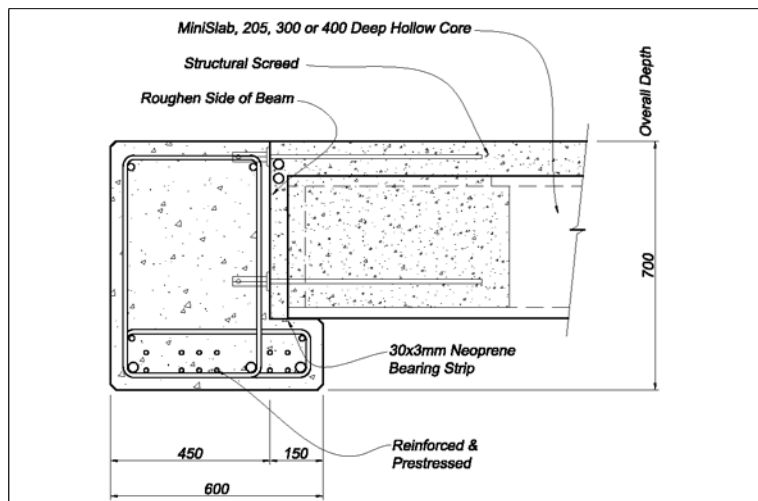

700 Wide PC Internal Beam

4.03

Load Span Chart

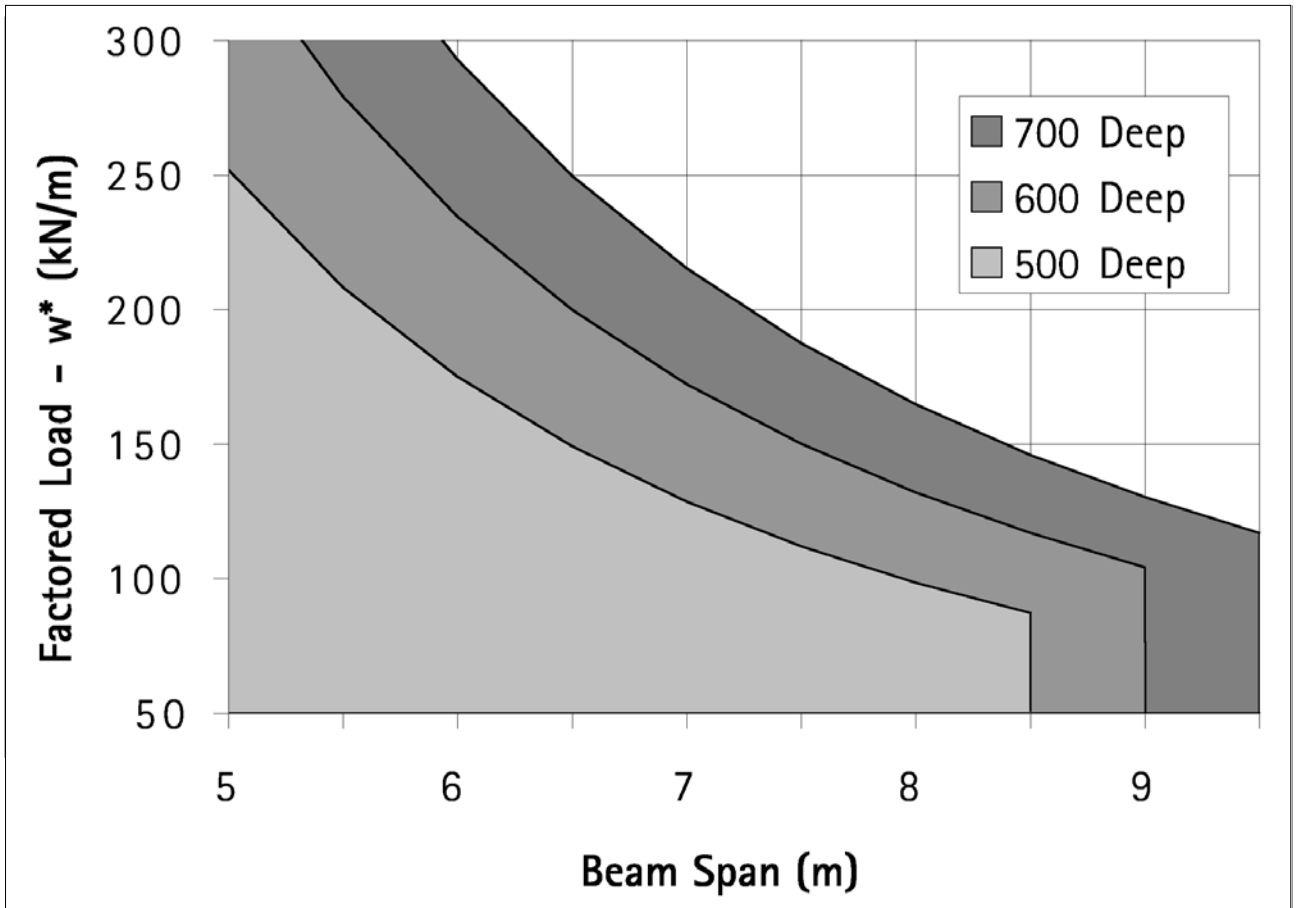

Band represents the range of beam capacities available with various strand and reinforcement configurations.

These tables are for guidance purposes only. Where deflections, point and/or line loading, vibration etc. require consideration please contact our technical department.

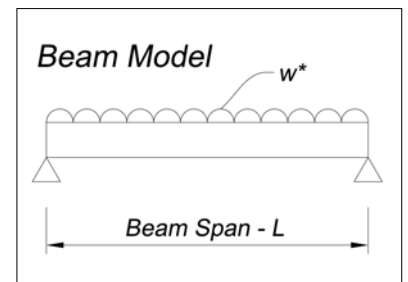

700 Wide PC Internal Beam

4.04

Beam Code	PCB7.500
Design Width	714mm
Number of Bottom Strands	7 - 14
Prestressing Strand	12.7 \varnothing
Concrete Grade	50MPa
Fire Rating	1½-4 hrs
Cross Sectional Area	228.6x10 ³ mm ²
Self Weight	572 kg/m

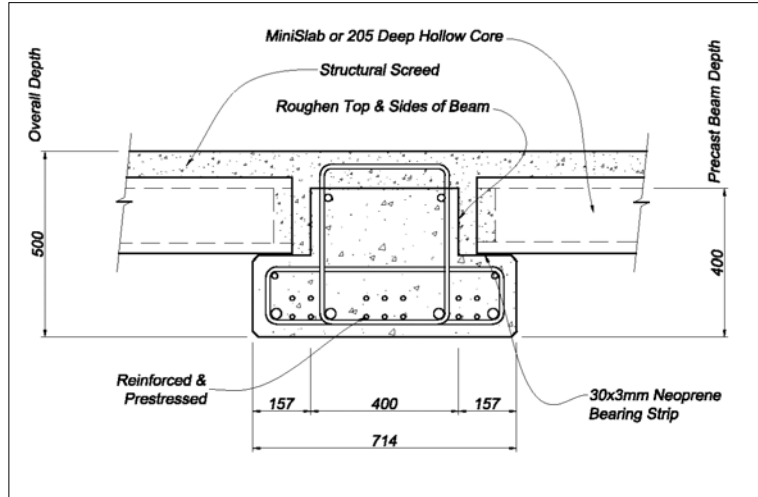

Beam Code	PCB7.600
Design Width	714mm
Number of Bottom Strands	7 - 14
Prestressing Strand	12.7 \varnothing
Concrete Grade	50MPa
Fire Rating	1½-4 hrs
Cross Sectional Area	284.3x10 ³ mm ²
Self Weight	711 kg/m

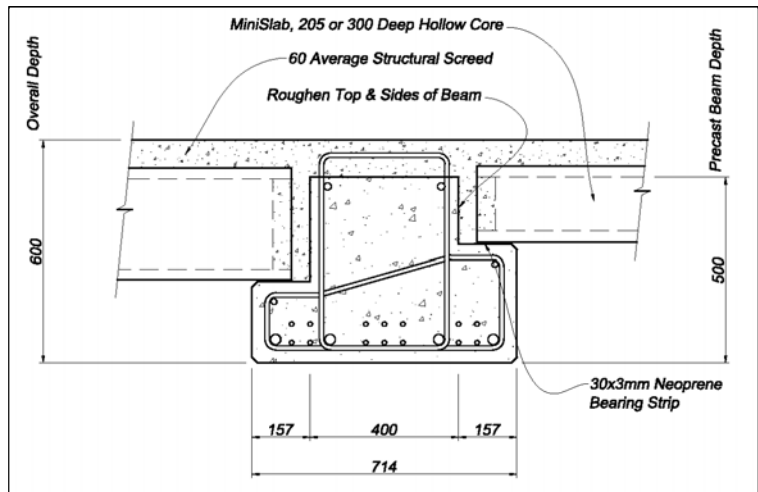

Beam Code	PCB6.700
Design Width	714mm
Number of Bottom Strands	7 - 14
Prestressing Strand	12.7 \varnothing
Concrete Grade	50MPa
Fire Rating	1½-4 hrs
Cross Sectional Area	302.4x10 ³ mm ²
Self Weight	756 kg/m

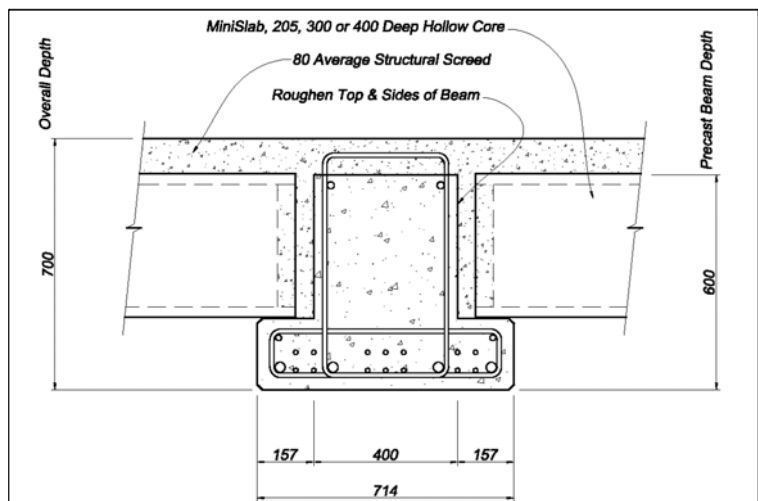

900 Wide PC Internal Beam

4.05

Load Span Chart

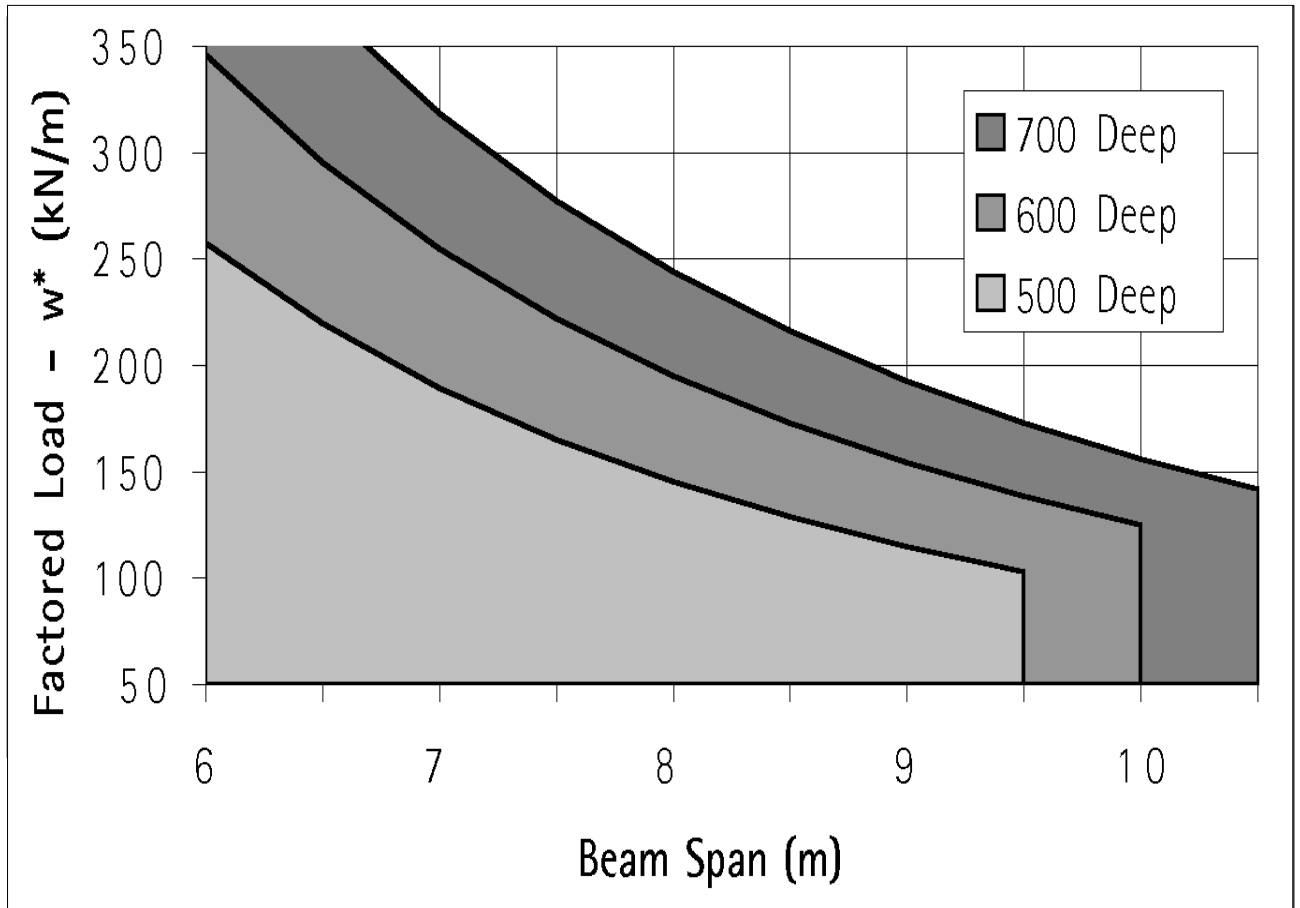

Band represents the range of beam capacities available with various strand and reinforcement configurations.

These tables are for guidance purposes only. Where deflections, point and/or line loading, vibration etc. require consideration please contact our technical department.

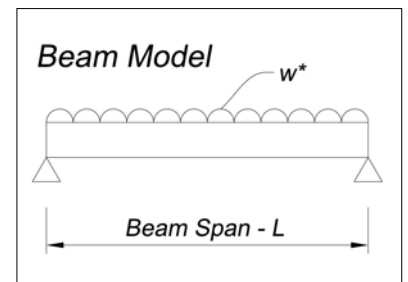

900 Wide PC Internal Beam

4.06

Beam Code	PCB9.500
Design Width	900mm
Number of Bottom Strands	11 - 22
Prestressing Strand	12.7 \emptyset
Concrete Grade	50MPa
Fire Rating	1½-4 hrs
Cross Sectional Area	306x10 ³ mm ²
Self Weight	765 kg/m

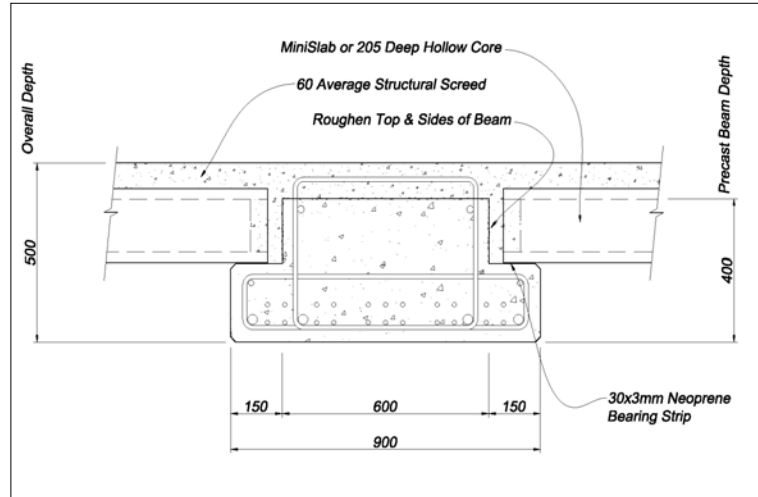

Beam Code	PCB9.600
Design Width	900mm
Number of Bottom Strands	11 - 22
Prestressing Strand	12.7 \emptyset
Concrete Grade	50MPa
Fire Rating	1½-4 hrs
Cross Sectional Area	381x10 ³ mm ²
Self Weight	953 kg/m

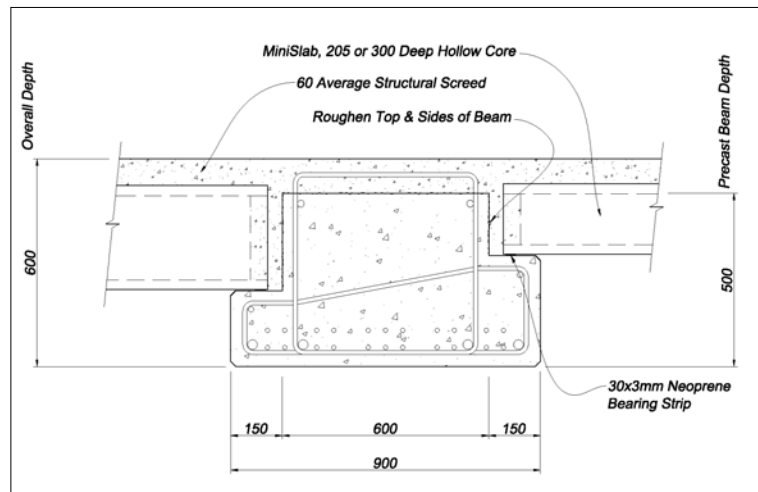

Beam Code	PCB9.700
Design Width	900mm
Number of Bottom Strands	11 - 22
Prestressing Strand	12.7 \emptyset
Concrete Grade	50MPa
Fire Rating	1½-4 hrs
Cross Sectional Area	420x10 ³ mm ²
Self Weight	1050 kg/m

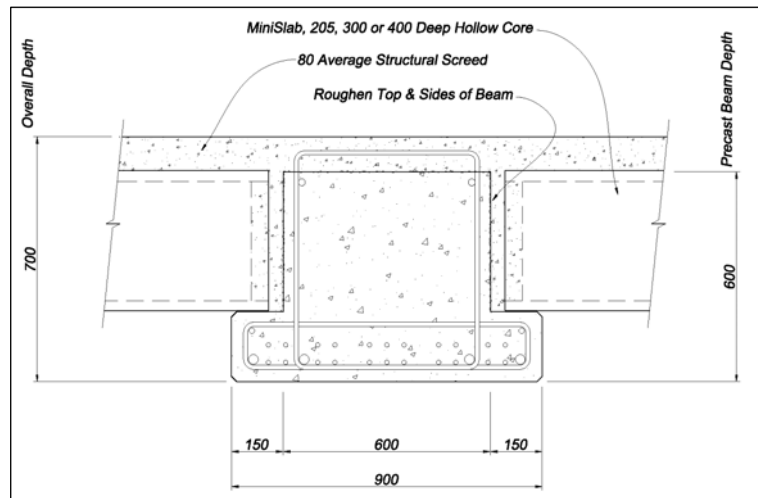

1200 Wide PC Internal Beam

4.07

Load Span Chart

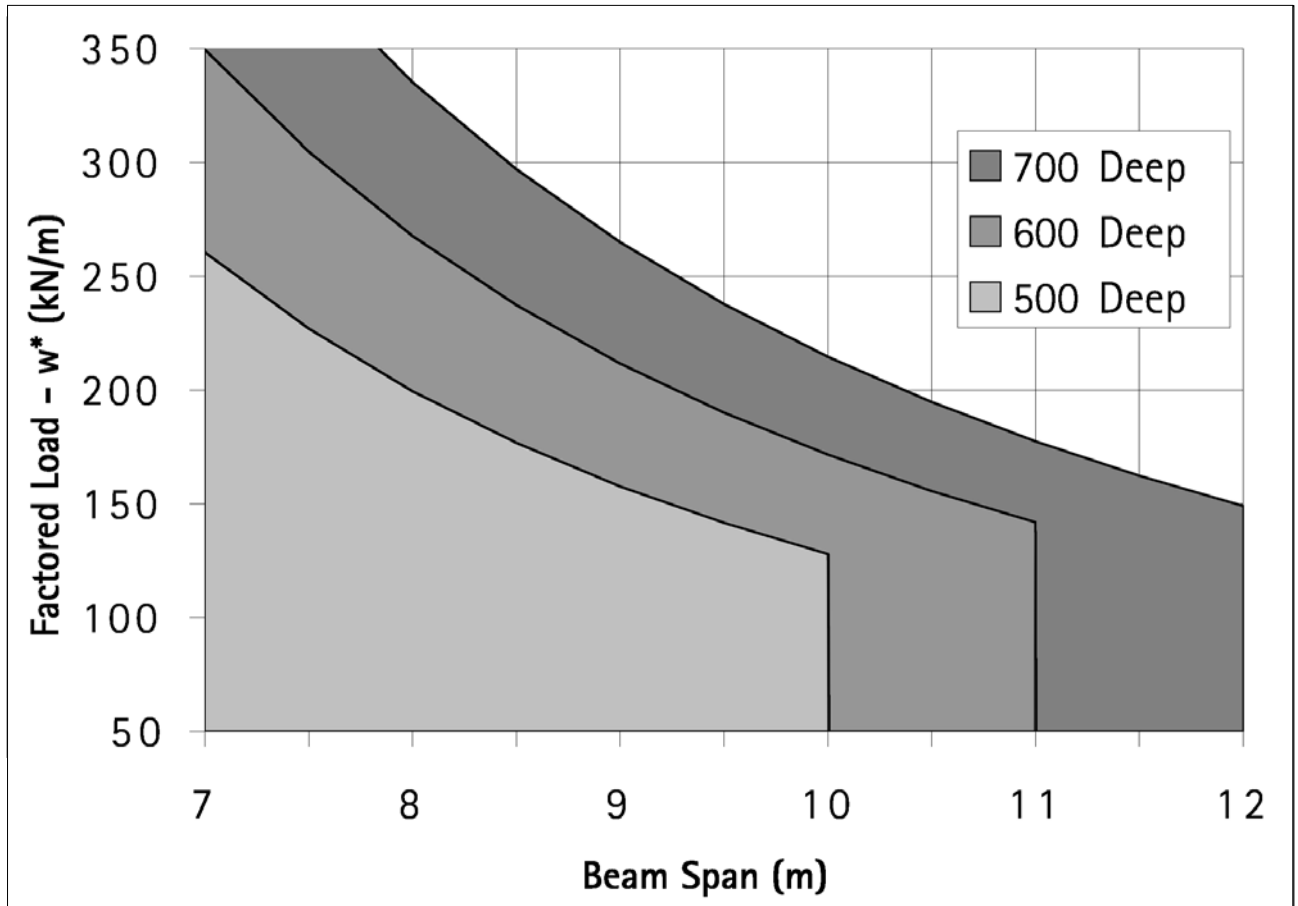

Band represents the range of beam capacities available with various strand and reinforcement configurations.

These tables are for guidance purposes only. Where deflections, point and/or line loading, vibration etc. require consideration please contact our technical department.

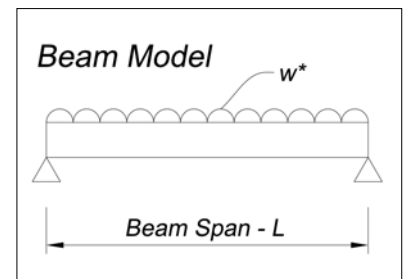

1200 Wide PC Internal Beam

4.08

Beam Code	PCB12.500
Design Width	1200mm
Number of Bottom Strands	15 - 30
Prestressing Strand	12.7 \emptyset
Concrete Grade	50MPa
Fire Rating	1½-4 hrs
Cross Sectional Area	426x10 ³ mm ²
Self Weight	1065 kg/m

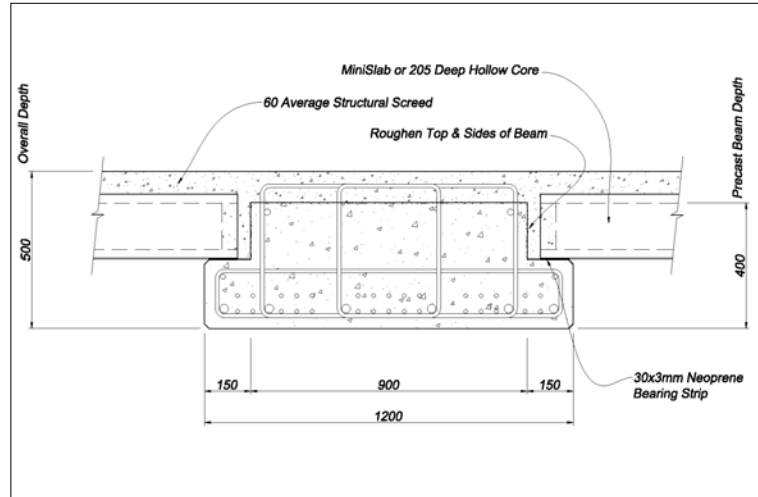

Beam Code	PCB12.600
Design Width	1200mm
Number of Bottom Strands	15 - 30
Prestressing Strand	12.7 \emptyset
Concrete Grade	50MPa
Fire Rating	1½-4 hrs
Cross Sectional Area	531x10 ³ mm ²
Self Weight	1328 kg/m

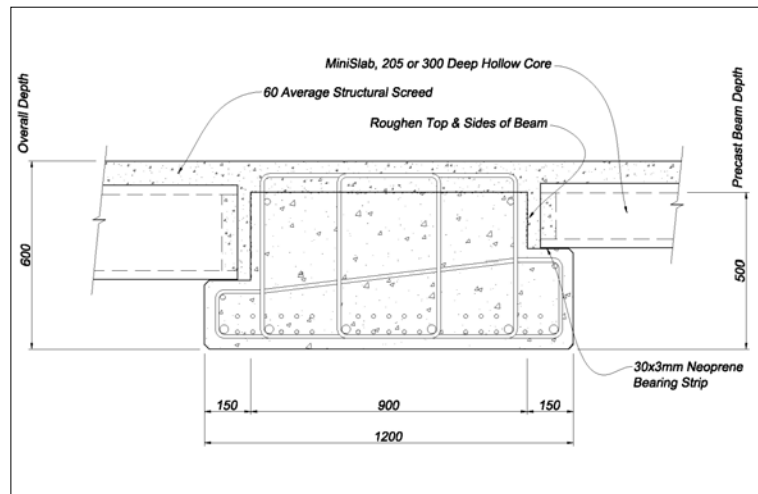

Beam Code	PCB12.700
Design Width	1200mm
Number of Bottom Strands	15 - 30
Prestressing Strand	12.7 \emptyset
Concrete Grade	50MPa
Fire Rating	1½-4 hrs
Cross Sectional Area	600x10 ³ mm ²
Self Weight	1500 kg/m

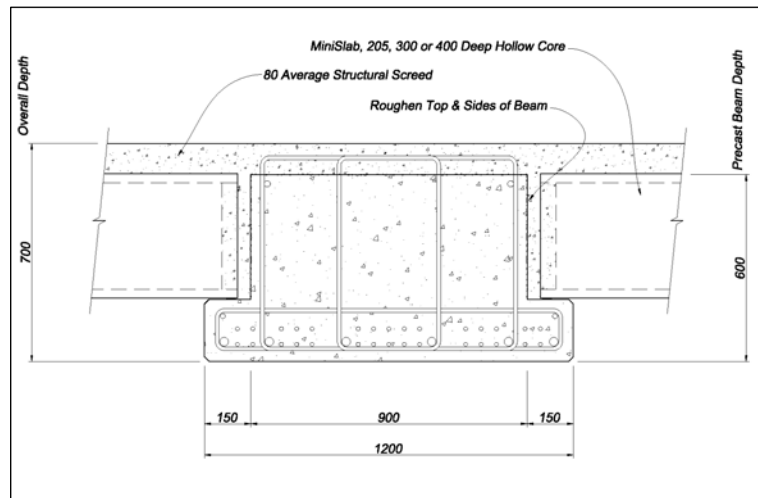

Precast Stair Details

5.01

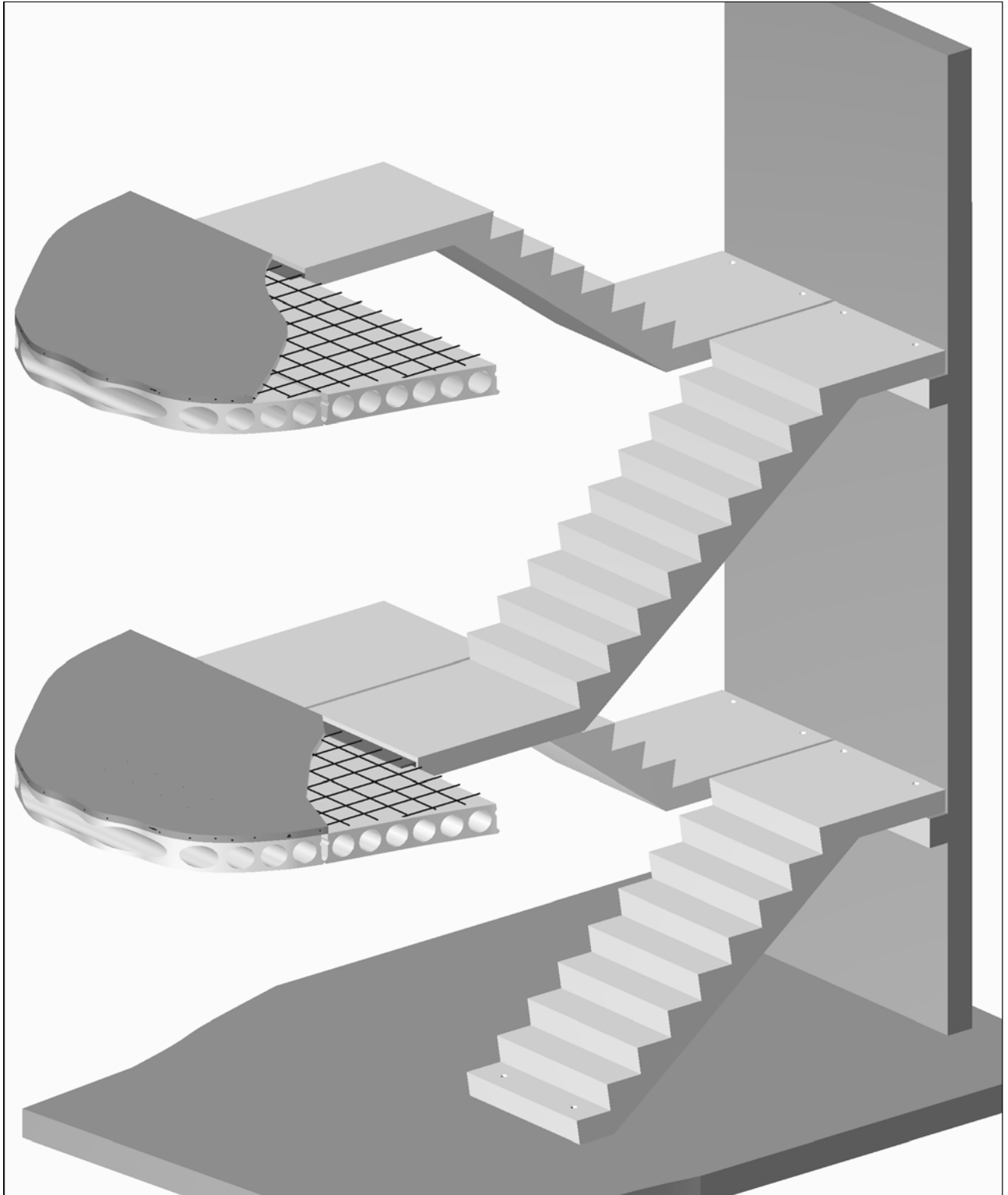

These diagrams are for guidance purposes only. Specific reinforcement and prestressing details have been omitted for clarity. Please contact our Technical department for specific project and/or component requirements.

Precast Stair to Footing Connection

5.02

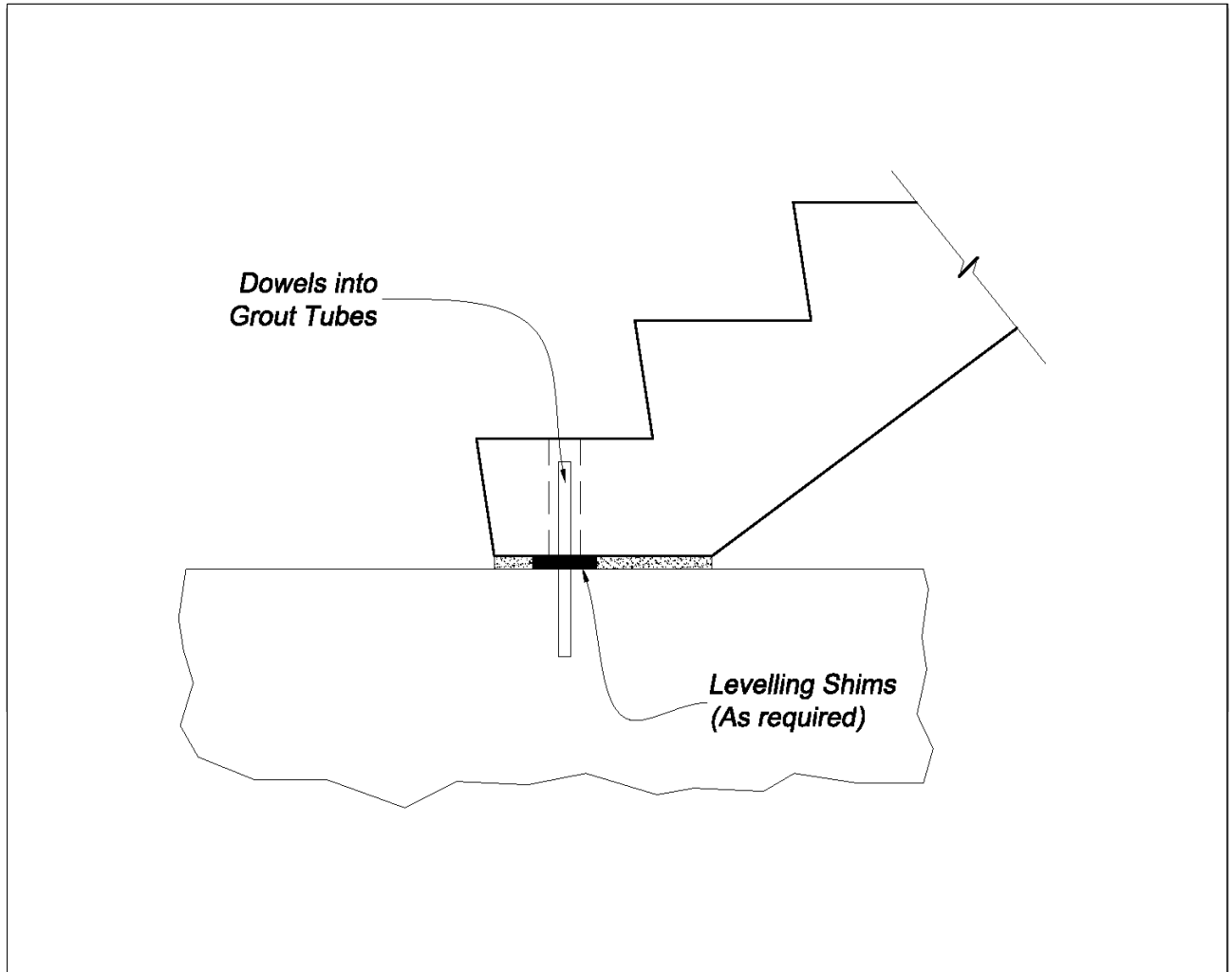

3-D Model

These diagrams are for guidance purposes only. Specific reinforcement and prestressing details have been omitted for clarity. Please contact our Technical department for specific project and/or component requirements.

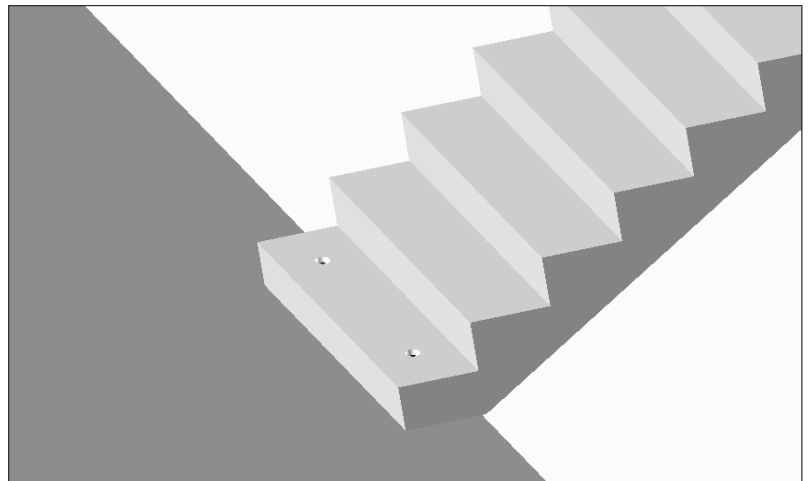

Precast Stair to Hollow Core Connection

5.03

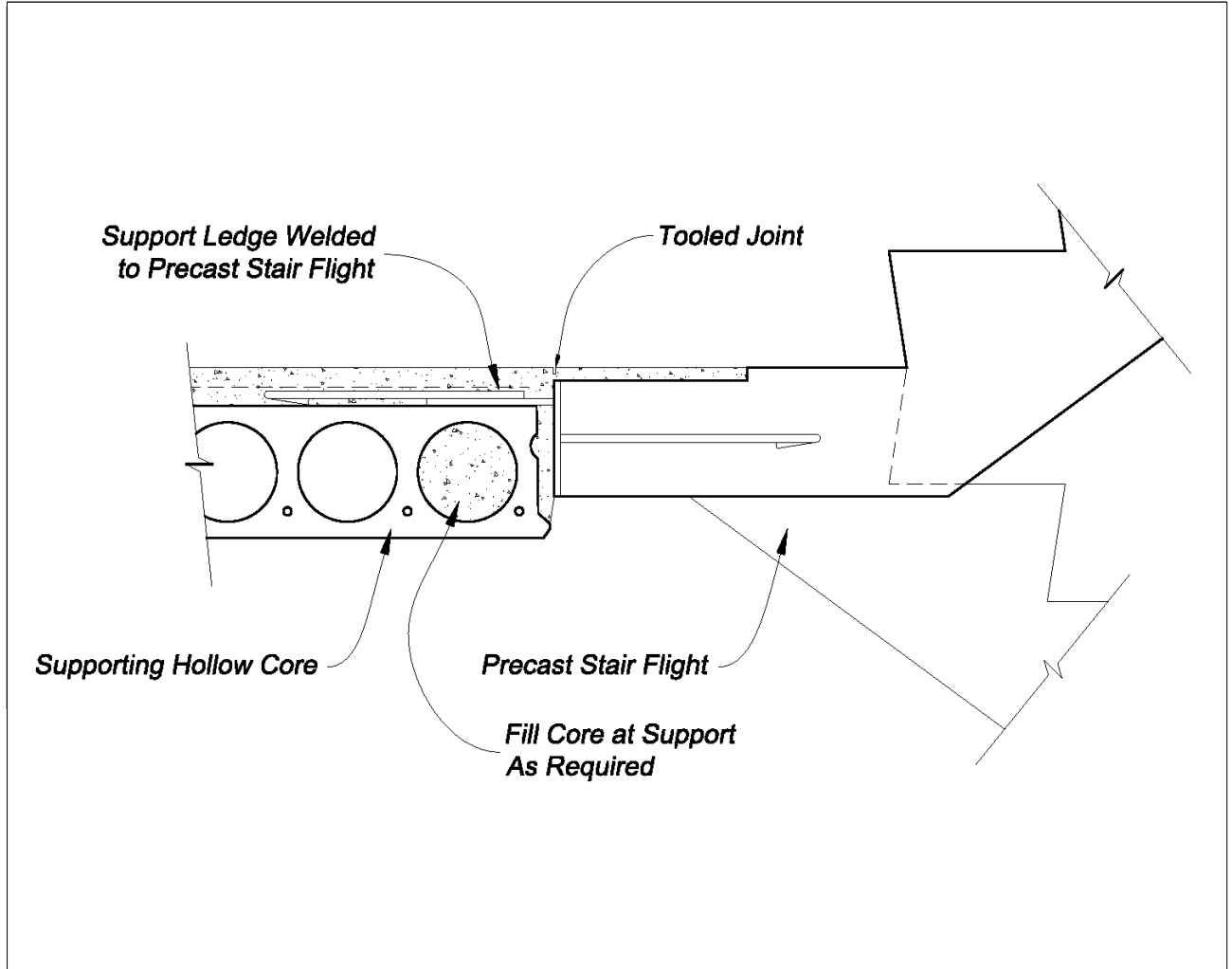

These diagrams are for guidance purposes only. Specific reinforcement and prestressing details have been omitted for clarity. Please contact our Technical department for specific project and/or component requirements.

3-D Model

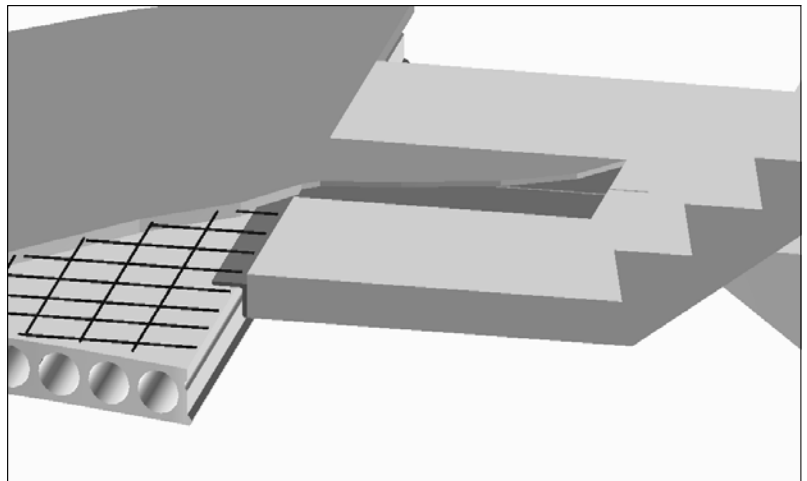

Precast Stair to Wall Connection

5.04

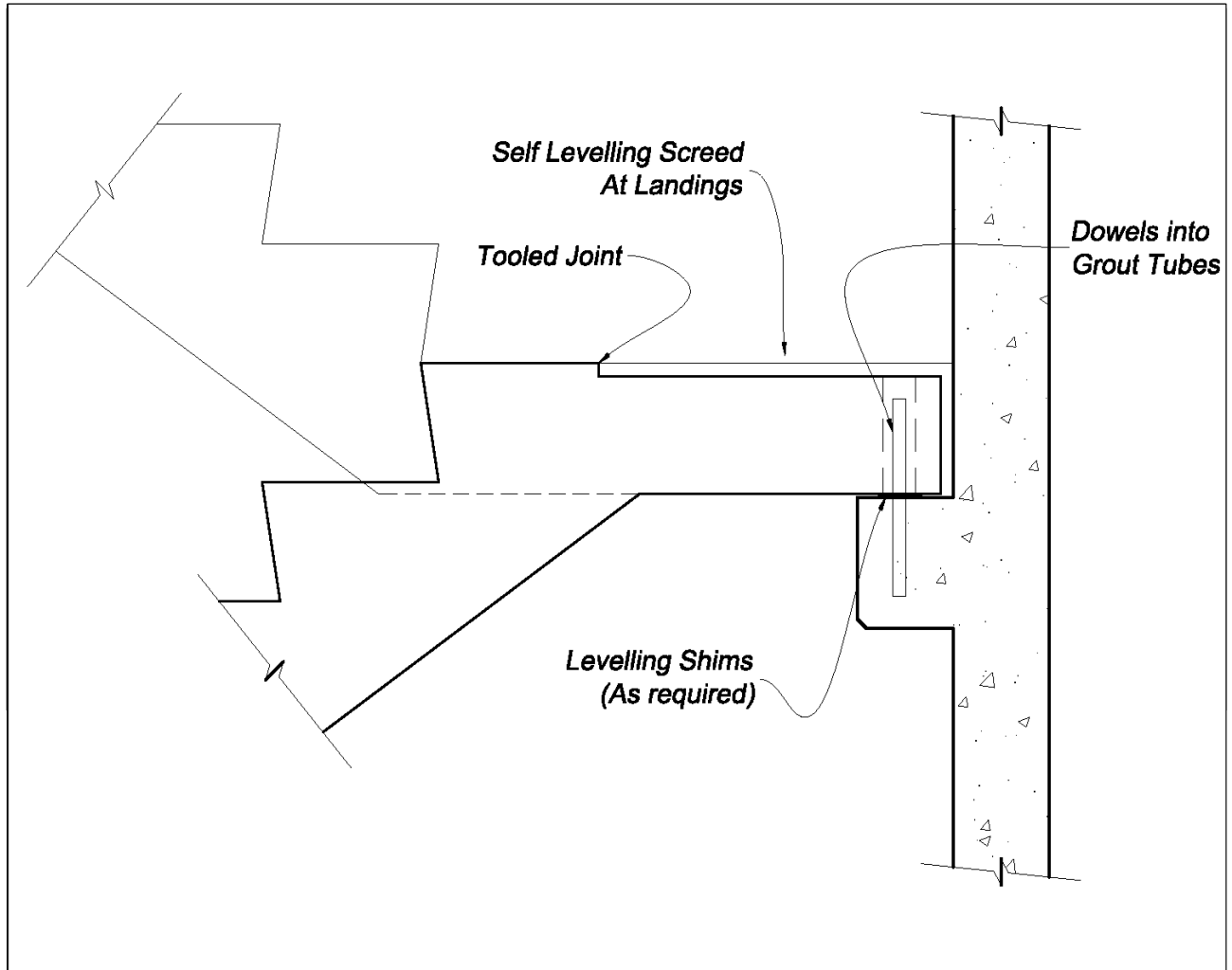

These diagrams are for guidance purposes only. Specific reinforcement and prestressing details have been omitted for clarity. Please contact our Technical department for specific project and/or component requirements.

3-D Model

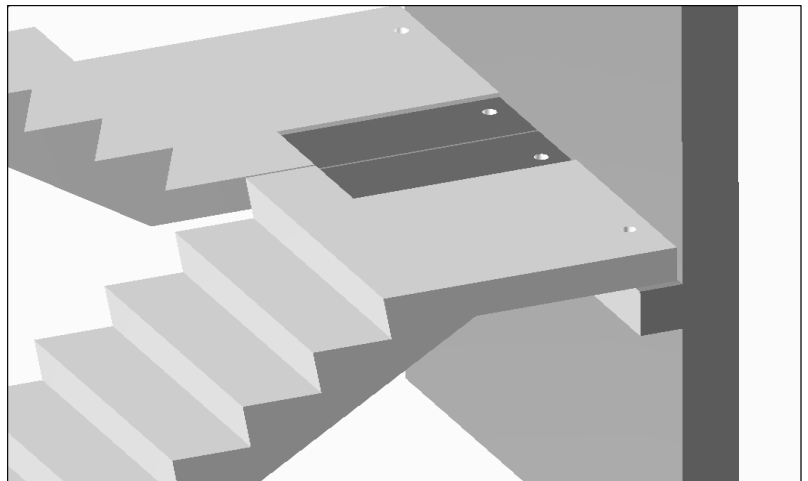

Beam to Hollow Core Connection

6.01

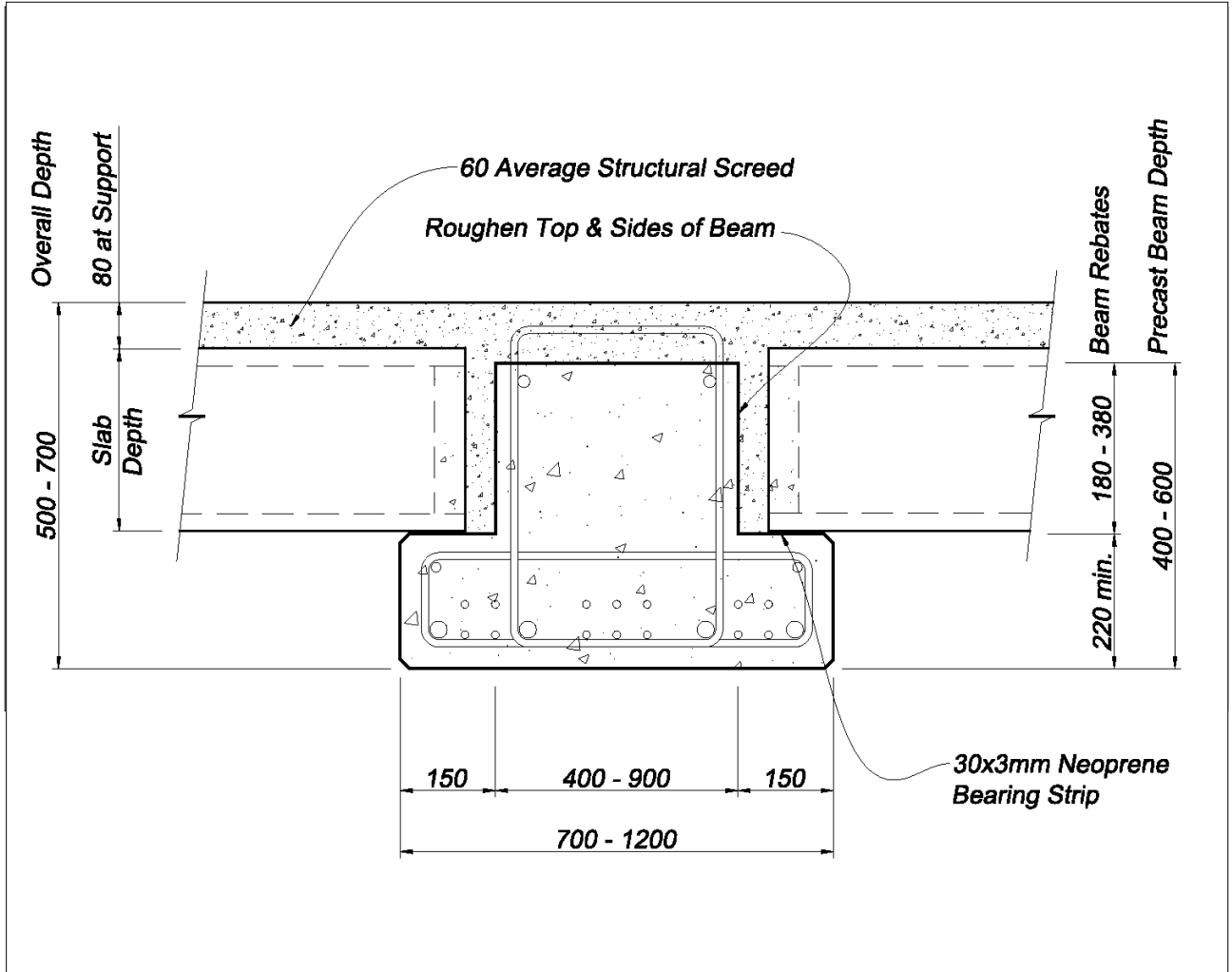

3-D Model

These diagrams are for guidance purposes only. Specific reinforcement and prestressing details have been omitted for clarity. Please contact our Technical department for specific project and/or component requirements.

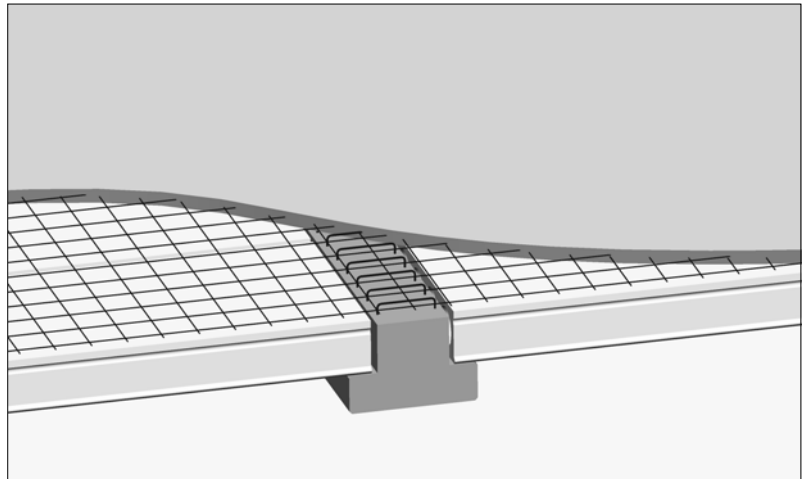

Beam, Column, Hollow Core Connection

6.02

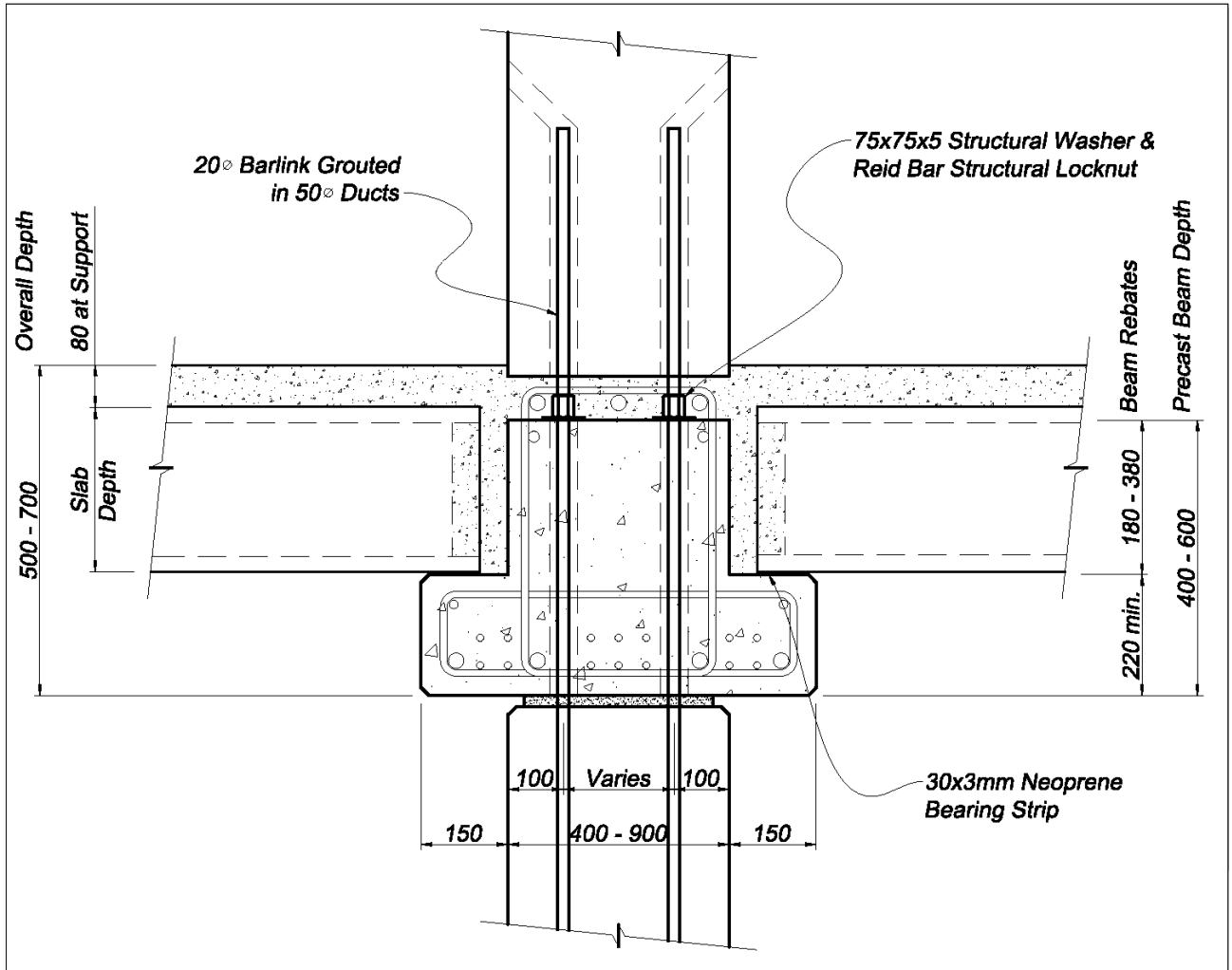

Example of Connection

These diagrams are for guidance purposes only. Specific reinforcement and prestressing details have been omitted for clarity. Please contact our Technical department for specific project and/or component requirements.



Beam to Hollow Core Connection

6.03

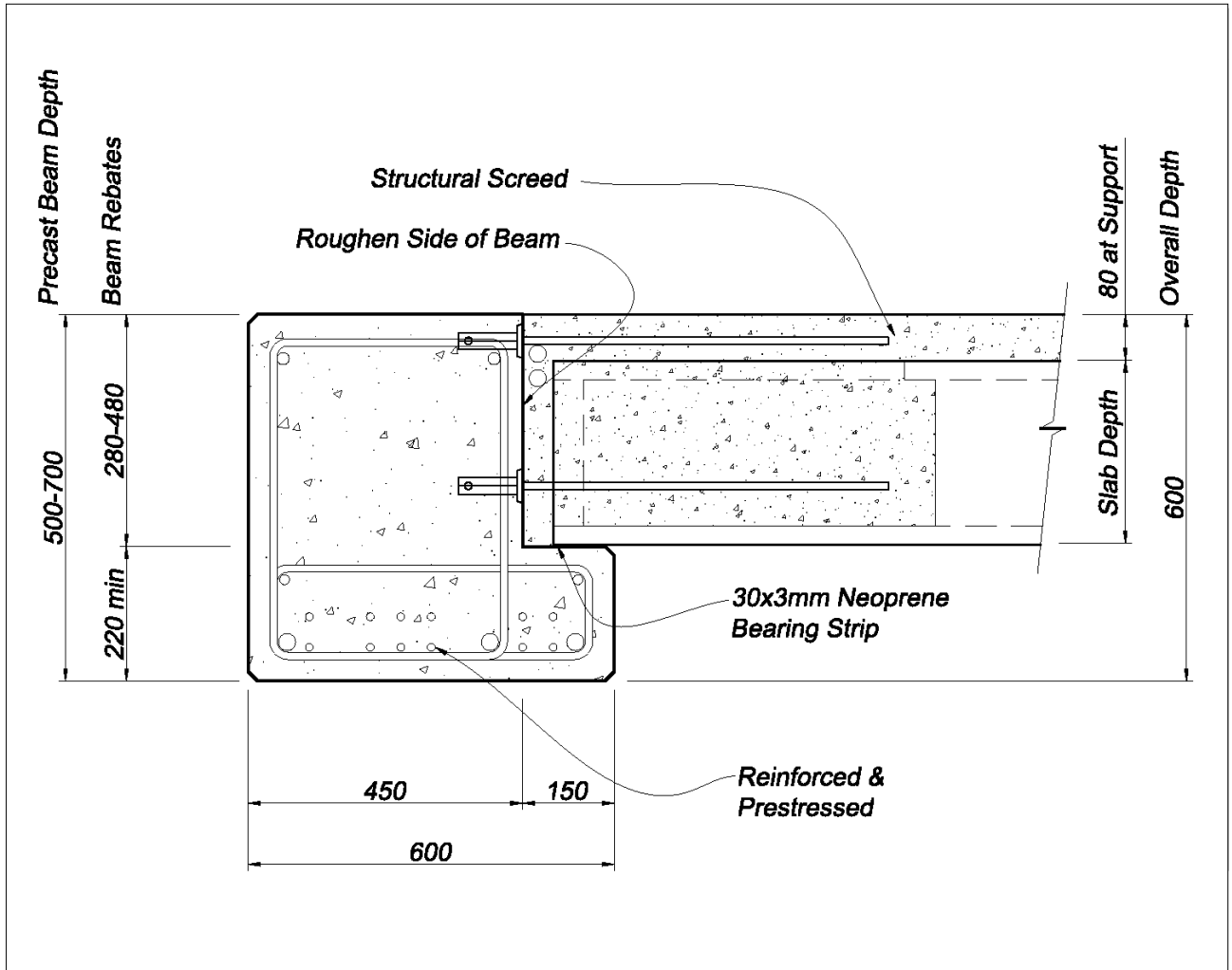

3-D Model

These diagrams are for guidance purposes only. Specific reinforcement and prestressing details have been omitted for clarity. Please contact our Technical department for specific project and/or component requirements.

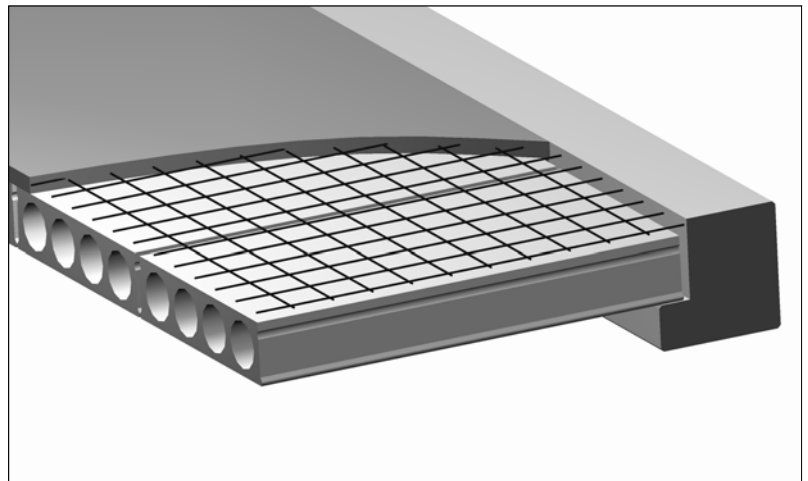

Wall to Hollow Core Connection

6.04

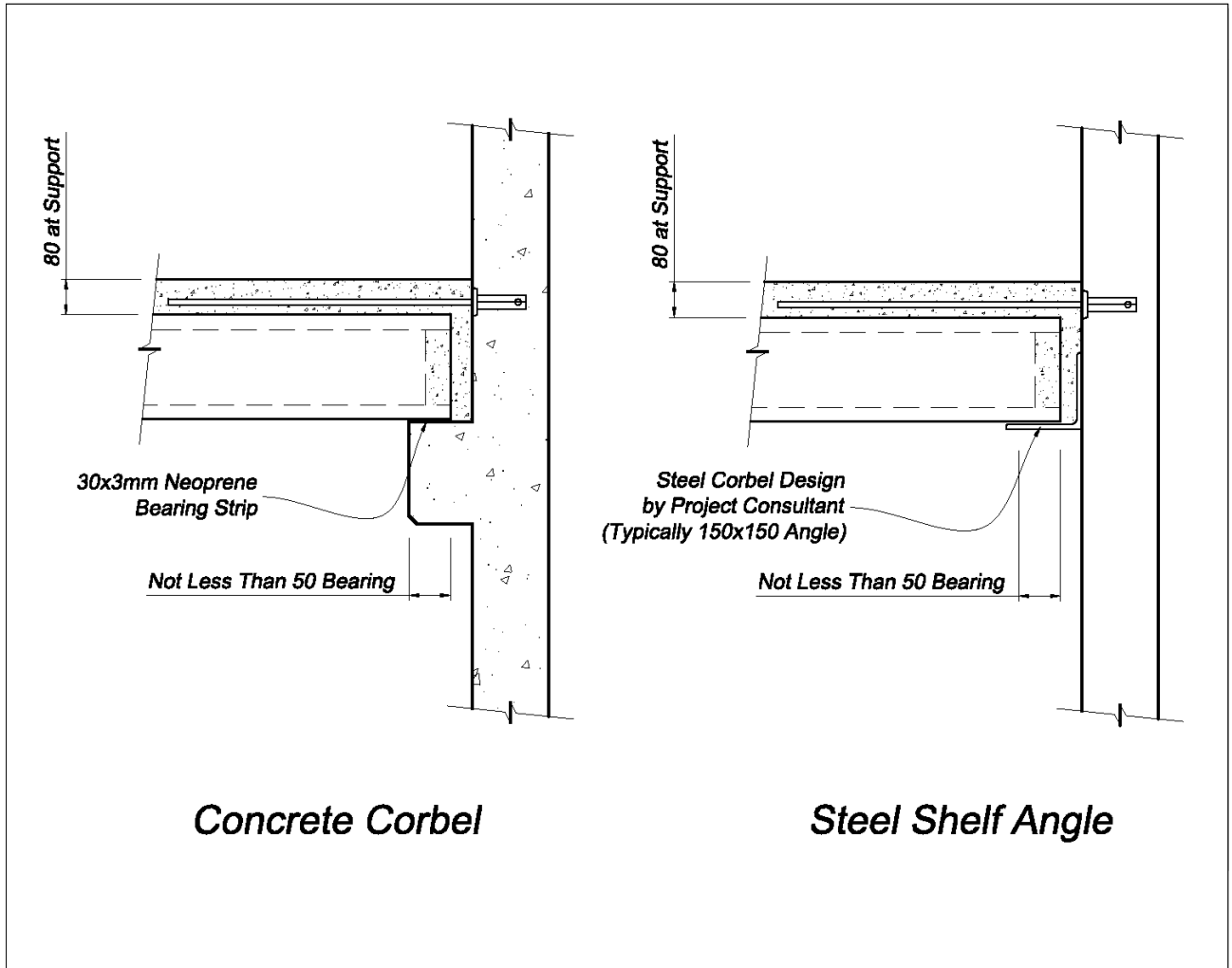

Example of Connection

These diagrams are for guidance purposes only. Specific reinforcement and prestressing details have been omitted for clarity. Please contact our Technical department for specific project and/or component requirements.



Wall to Hollow Core Connection

6.05

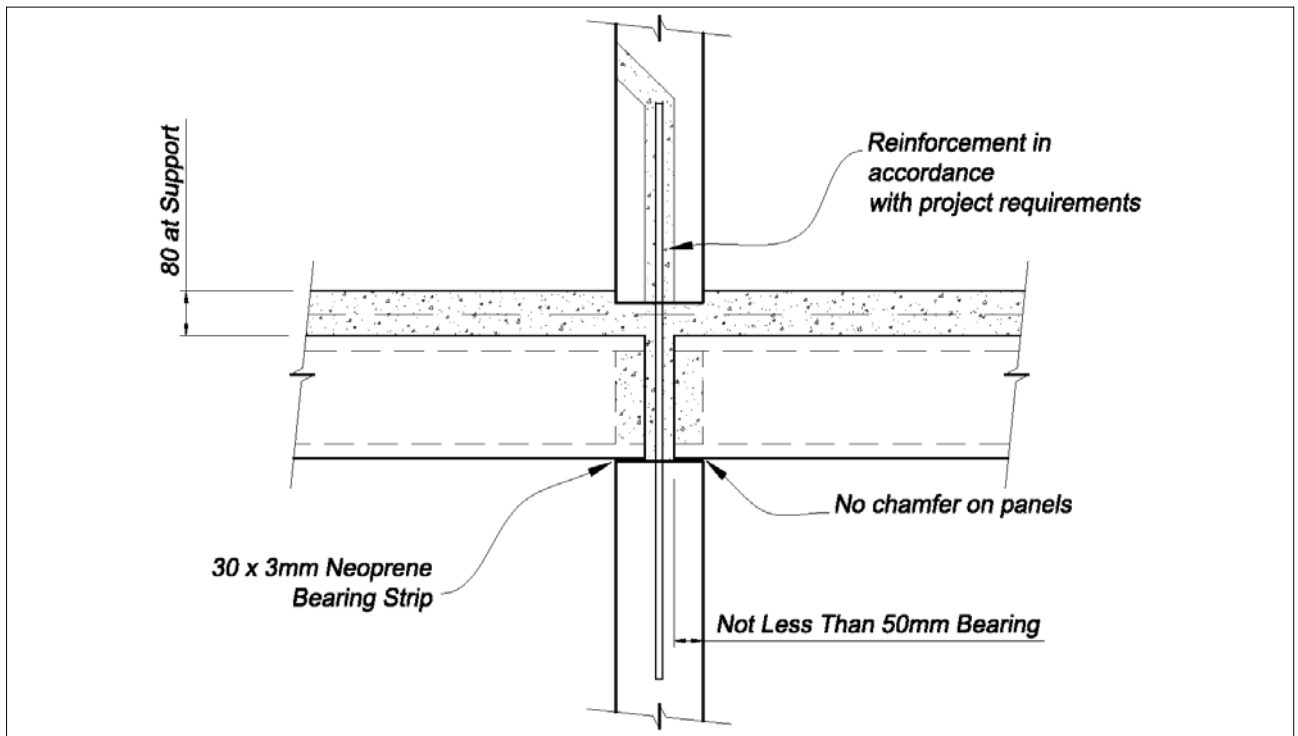
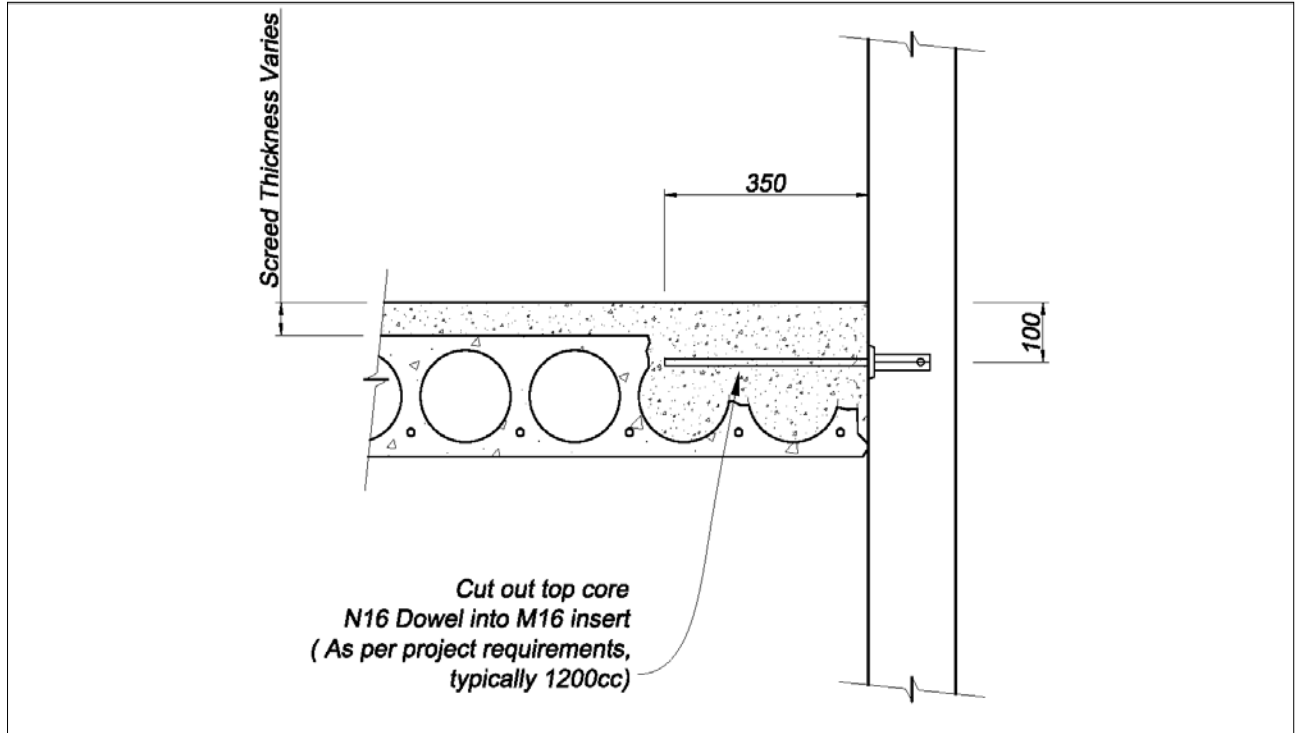

These diagrams are for guidance purposes only. Specific reinforcement and prestressing details have been omitted for clarity. Please contact our Technical department for specific project and/or component requirements.

Steel Trimmer Beam Detail

6.06

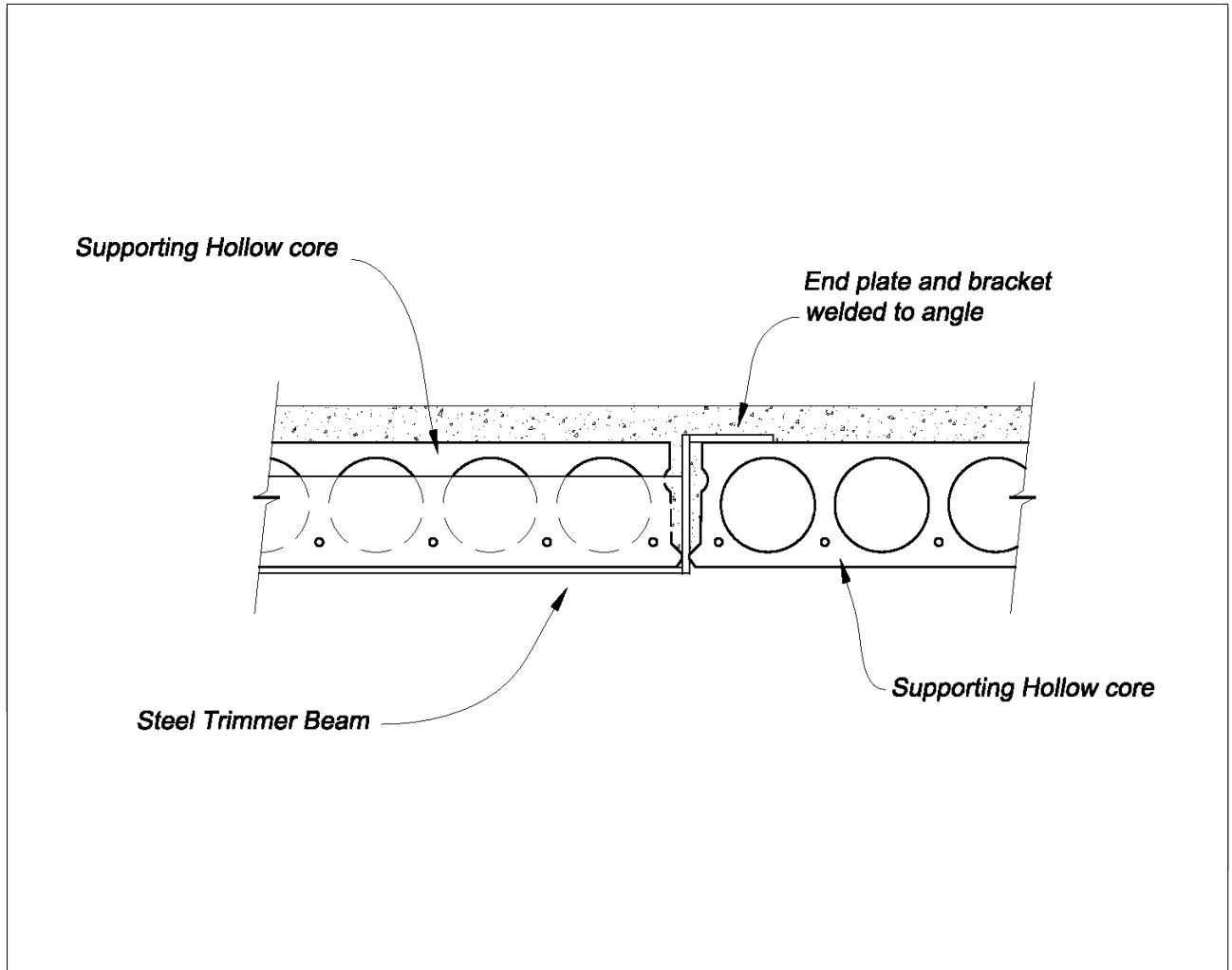

These diagrams are for guidance purposes only. Specific reinforcement and prestressing details have been omitted for clarity. Please contact our Technical department for specific project and/or component requirements.

3-D Model

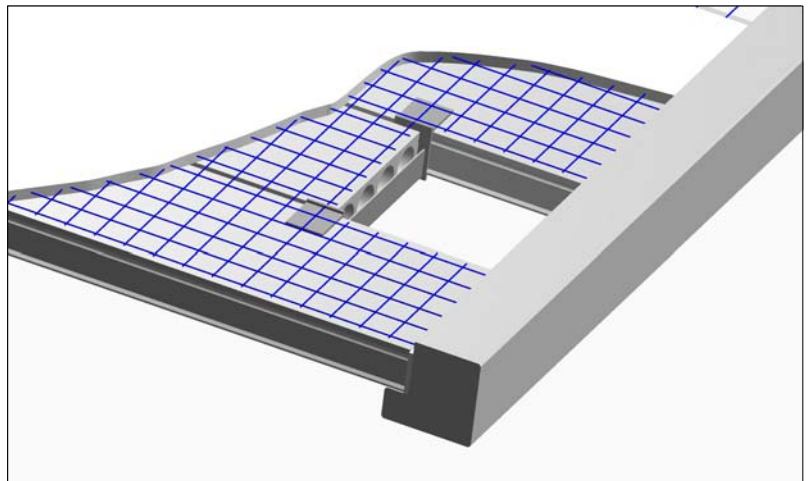

Steel Beam to Hollow Core Connection

6.07

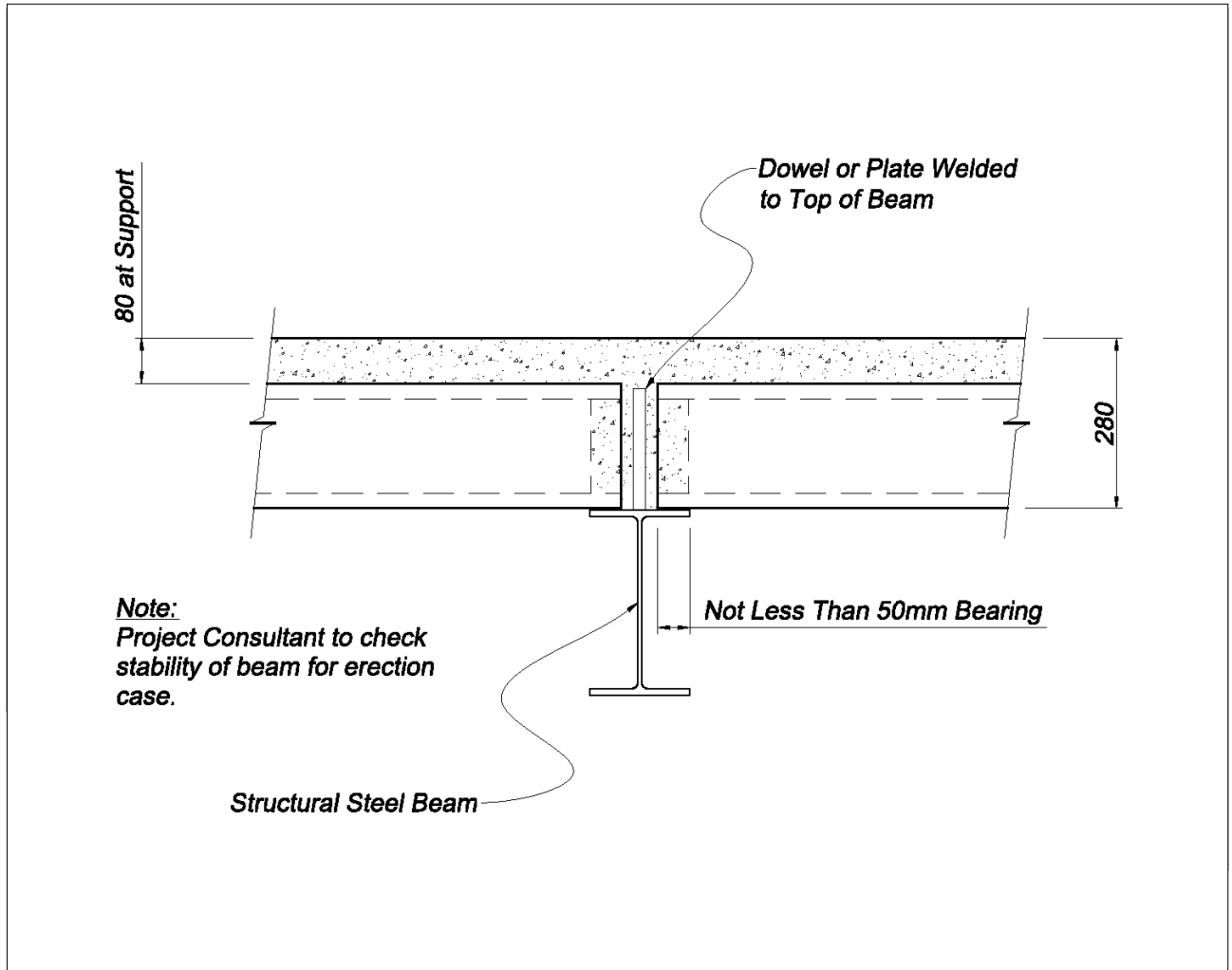

3-D Model

These diagrams are for guidance purposes only. Specific reinforcement and prestressing details have been omitted for clarity. Please contact our Technical department for specific project and/or component requirements.

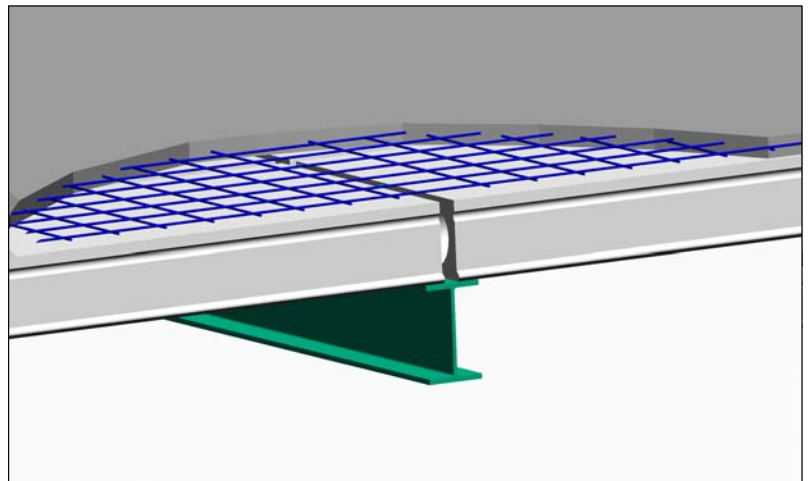

Steel Beam to Hollow Core Connection

6.08

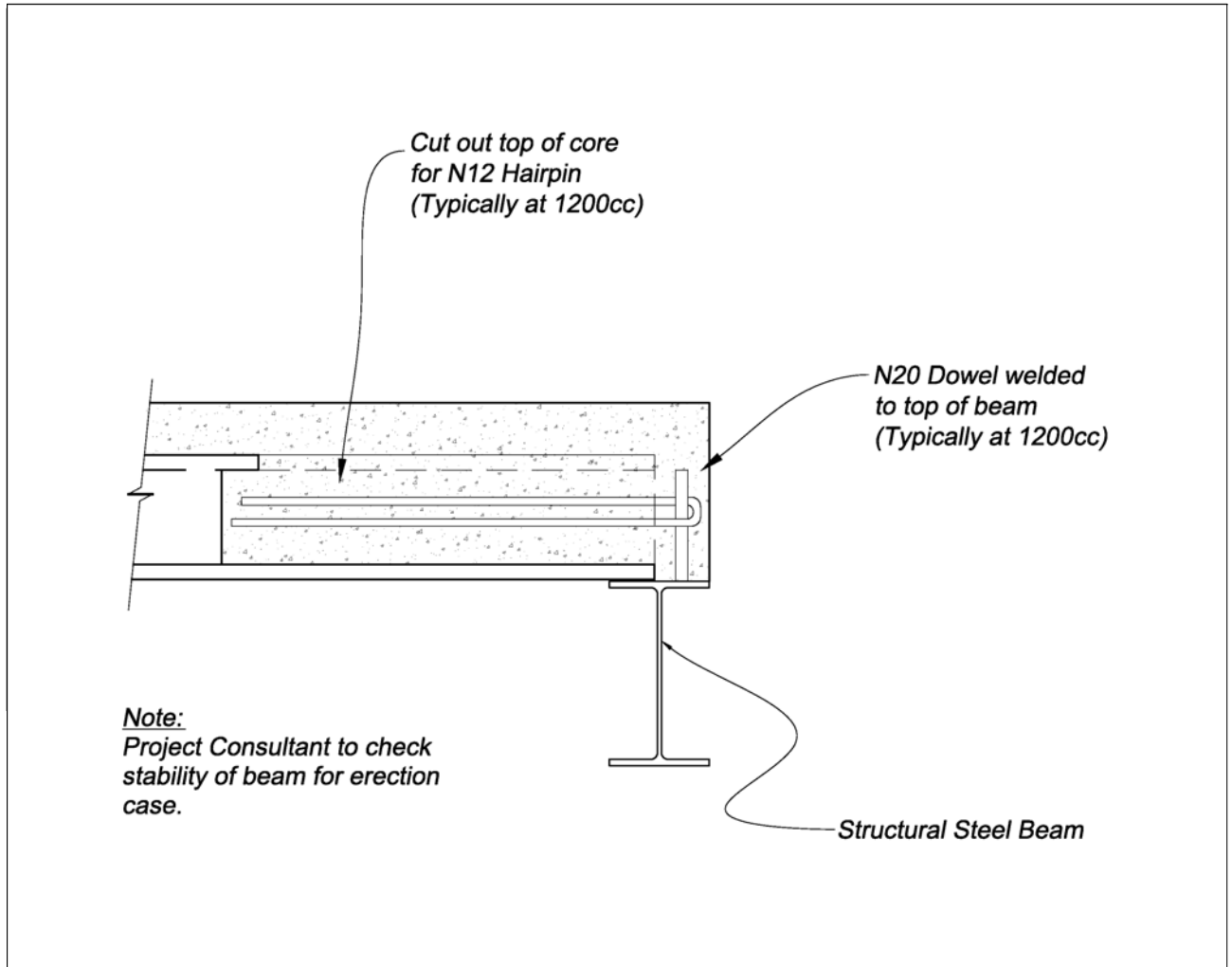

These diagrams are for guidance purposes only. Specific reinforcement and prestressing details have been omitted for clarity. Please contact our Technical department for specific project and/or component requirements.

3-D Model

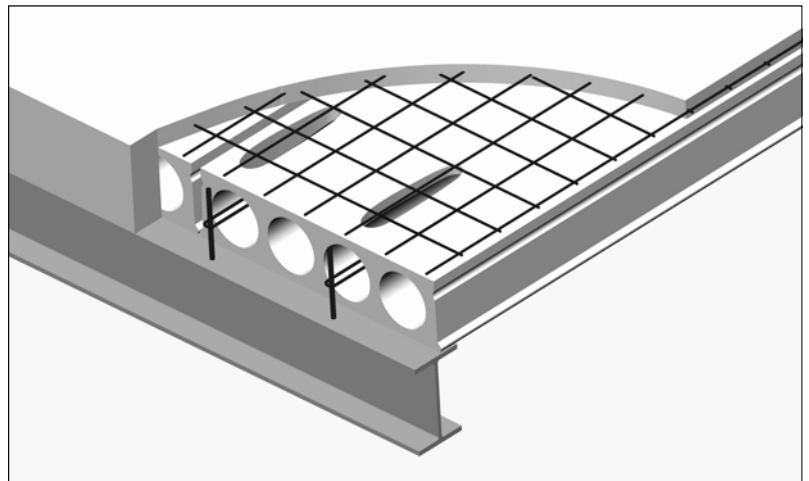

Column Base Connection

6.09

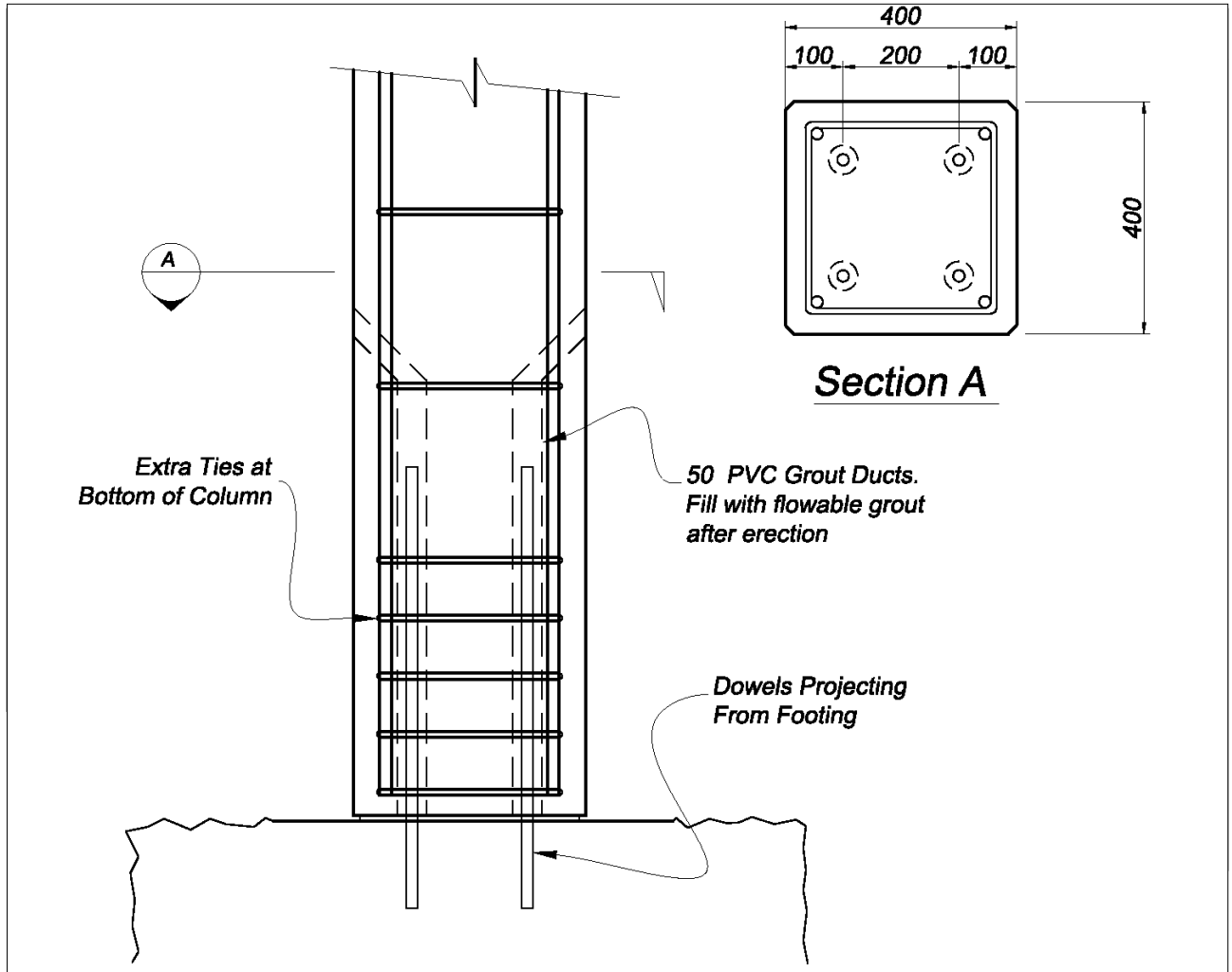

These diagrams are for guidance purposes only. Specific reinforcement and prestressing details have been omitted for clarity. Please contact our Technical department for specific project and/or component requirements.



HOLLOWCORE

HOLLOW CORE CONCRETE PTY LTD

12-14 Maria Street, Laverton North, VIC 3026, Australia

Tel: +61 3 9369 4944 Fax: +61 3 9369 2025 Email: info@hollowcore.com.au Web: www.hollowcore.com.au