



Rolls-Royce

# Acoustic liners for modern aero-engines

Andrew Kempton

Chief Noise Specialist, Rolls-Royce

Visiting Professor, University of Southampton

© 2011 Rolls-Royce plc

The information in this document is the property of Rolls-Royce plc and may not be copied or communicated to a third party, or used for any purpose other than that for which it is supplied without the express written consent of Rolls-Royce plc.

This information is given in good faith based upon the latest information available to Rolls-Royce plc, no warranty or representation is given concerning such information, which must not be taken as establishing any contractual or other commitment binding upon Rolls-Royce plc or any of its subsidiary or associated companies.

# The Noise Challenge



*Photo Opportunity: Start Sat 23rd Nov, 9.30am, BANG! and BFOE protesters with banners, placards masks, and a truck with loud speakers*

*Aircraft Noise - It Takes The Peace!*



Last Updated: Monday, 10 March, 2003, 21:36 GMT

[✉ Email this to a friend](#)

[🖨️ Printable version](#)

## Family sue over jet noise

The owners of a 17th Century house are claiming £9m in compensation from the Ministry of Defence (MoD) over "unbearable" aircraft noise from RAF Harrier jets.



The planes fly over the house when they are coming in to land

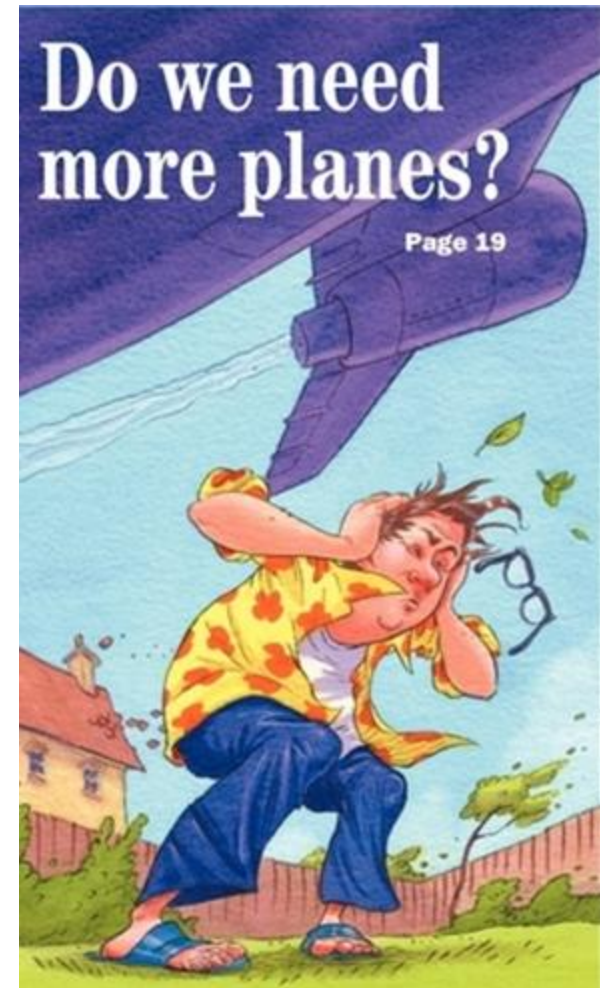

Rolls-Royce

# The Future of Air Transport – 2003 UK White Paper

*UK air travel has increased five-fold over the last 30 years*

*Air travel will continue growing over the next 30 years*

*Half the population now flies at least once a year*

*We need a balanced approach which recognises the importance of air travel, but which also tackles environmental issues*

*Aviation helps people stay in touch with friends and family around the world.*

*Airports are important to the economies of the regions*

*The aviation industry directly supports around 200,000 jobs.*



# Significant progress in reducing aircraft noise

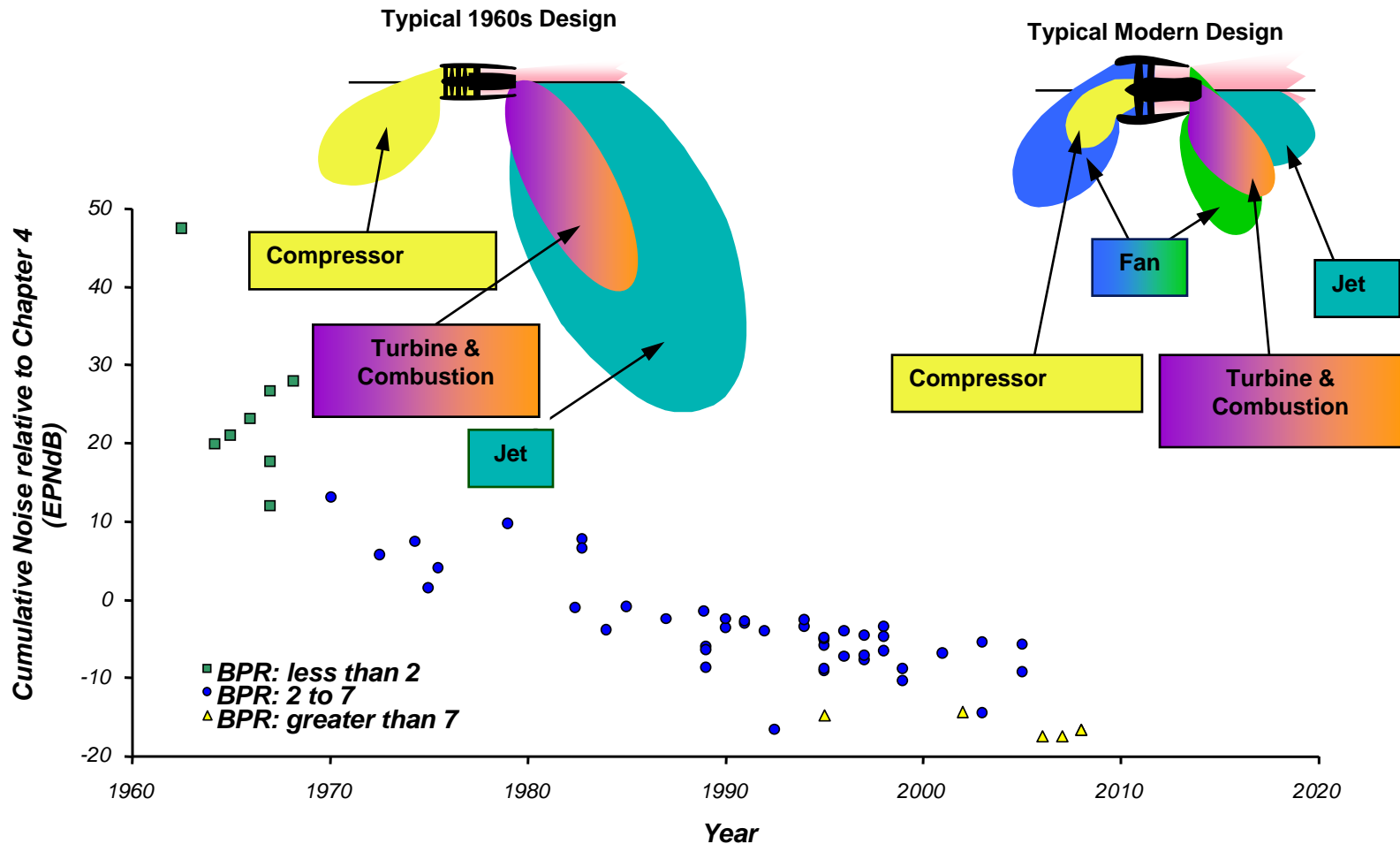

Very significant progress in reducing jet noise was achieved by the introduction of high-bypass-ratio engines



Rolls-Royce

# Presentation Content

- **Acoustic liner requirements**
- **Zero-splice intake liners**
- **Intake lip liners**
- **Bypass-duct liners**
- **Core-duct liners**
- **Liner types**
- **Measurement of liner attenuations**
- **Measurement of liner impedance**
- **Liner impedance models**



# Aero-Engine Liners

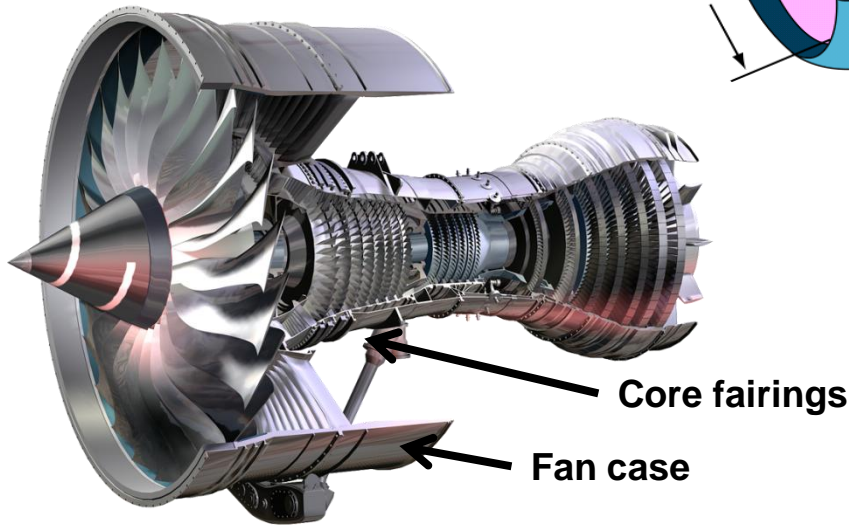
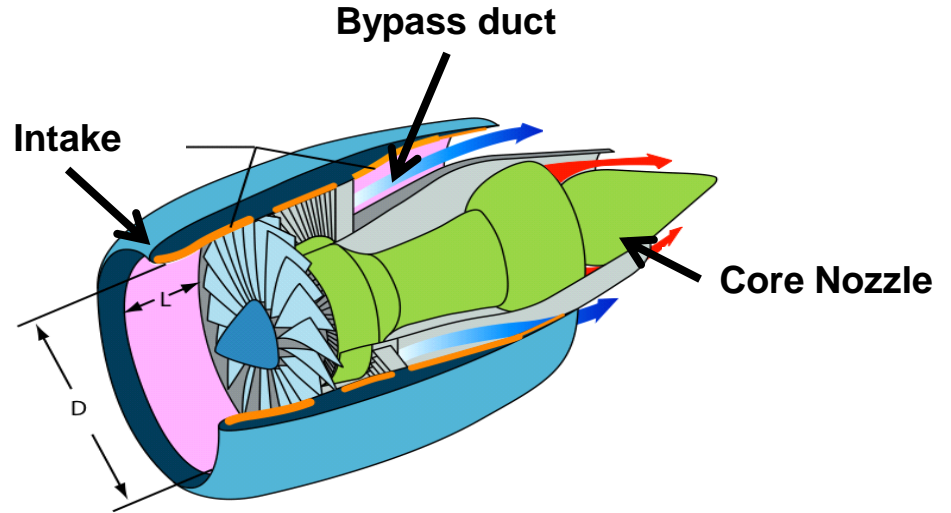

# Acoustic Liner Requirements

**Acoustic Liners are fundamental in ensuring jet aircraft are quiet, but they must also satisfy many other requirements:**

- **Must be effective over a wide range of engine operating conditions and frequencies (reducing both tones and broadband noise)**
- **Must fit into the restricted space available (liner depth and area)**
- **Must be light to ensure that fuel burn is not penalised**
- **Must be cost effective to buy their way onto the aircraft**
- **Must be specified when many details of the airframe and engine design have not been finalised, so the liner design must be robust**
- **Must be integrated with other engine design requirements**
- **Must survive rain, ice, oil leaks, maintenance staff ...**
- **Must satisfy manufacturability and maintainability requirements, for decades of in-service life in the exacting aero-engine environment**



# Progress towards zero-splice intakes



Rolls-Royce/Boeing QTD

Much progress has been made in improving the acoustic performance of intake liners. Axial splices scatter energy from nearly cut-off modes into modes not so well attenuated by liner



Rolls-Royce/Airbus SILENCE(R)



Rolls-Royce



# Progress towards zero-splice intakes

Improved manufacturing techniques have enabled the zero-splice intake liner now to enter service on the A380 and B787



Why are zero-splice intake liners so effective in reducing fan tones?

*With acknowledgements to Airbus*

# Modal structure of fan blade-passing-frequency (BPF) tone

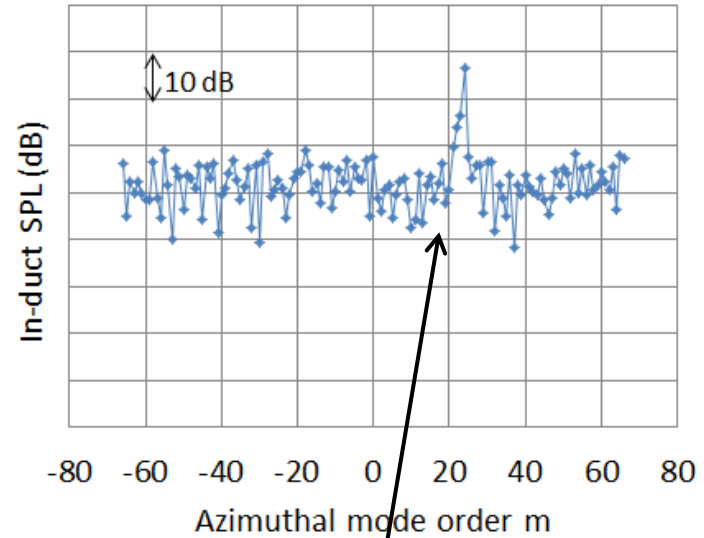
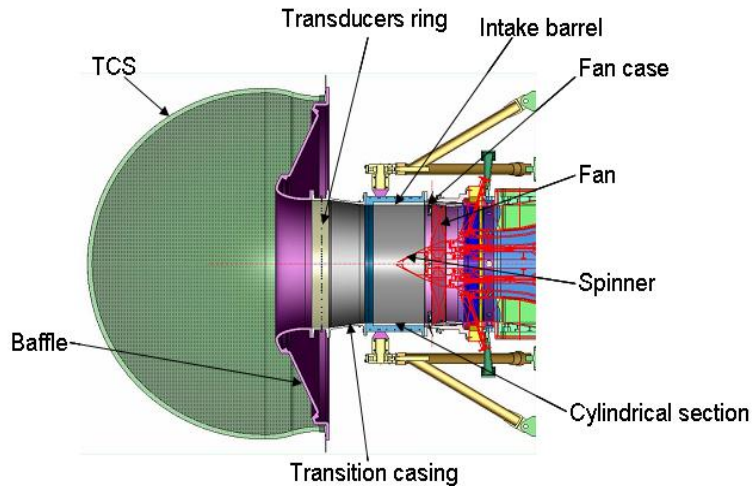

**At supersonic fan tip speeds  
the rotor-alone tone cuts on  
( $m=24$  at BPF for 24-bladed fan)**



**Rolls-Royce**

# Influence of modal structure on liner attenuations

## Fan BPF tone

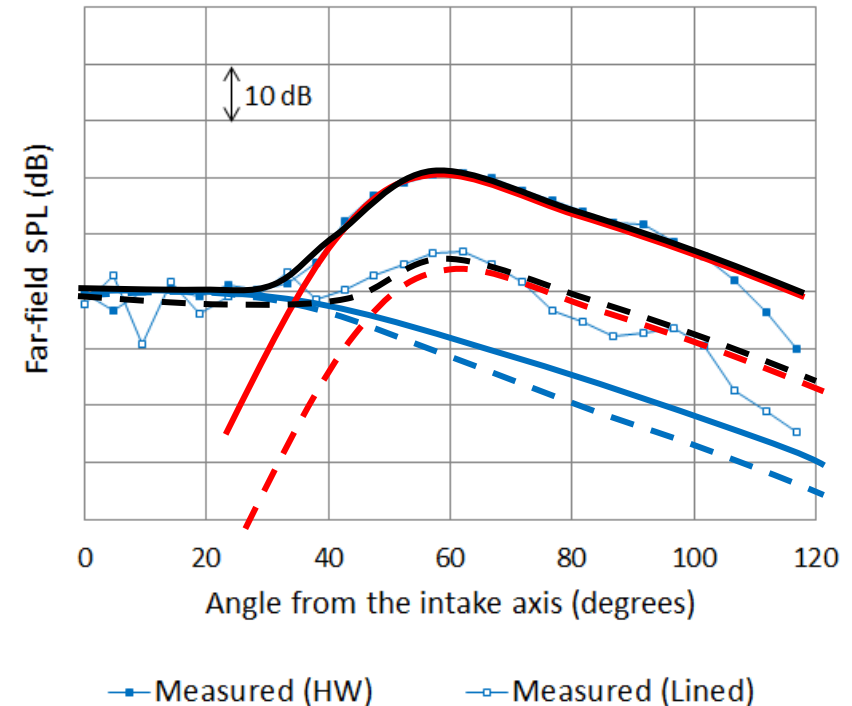
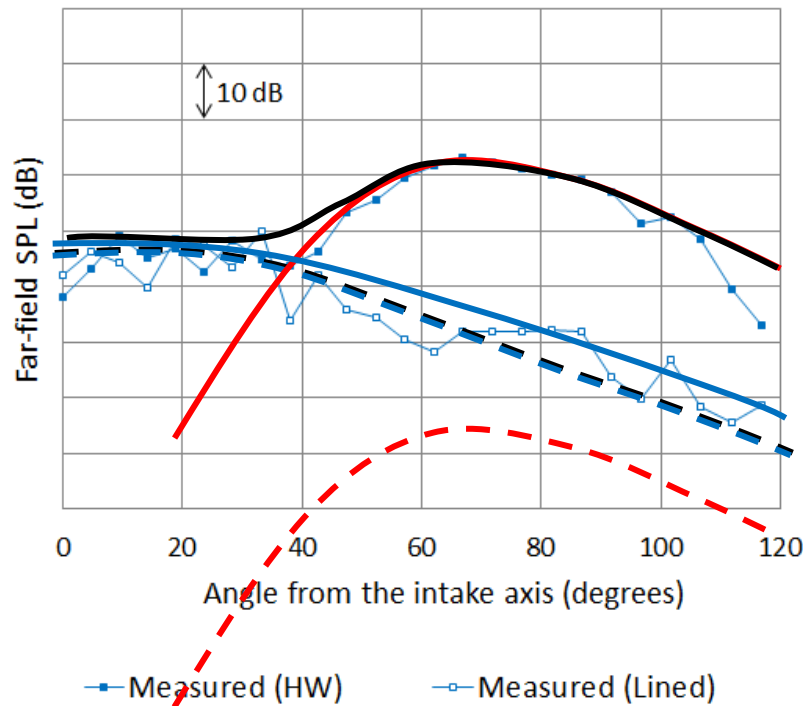

Tip speed just supersonic

Tip speed well supersonic

— Rotor-locked

— Multimodal

— Total

**Understanding the modal structure is key to understanding the liner attenuations**



Rolls-Royce

# Prediction of fan BPF tone

With acknowledgements to ISVR

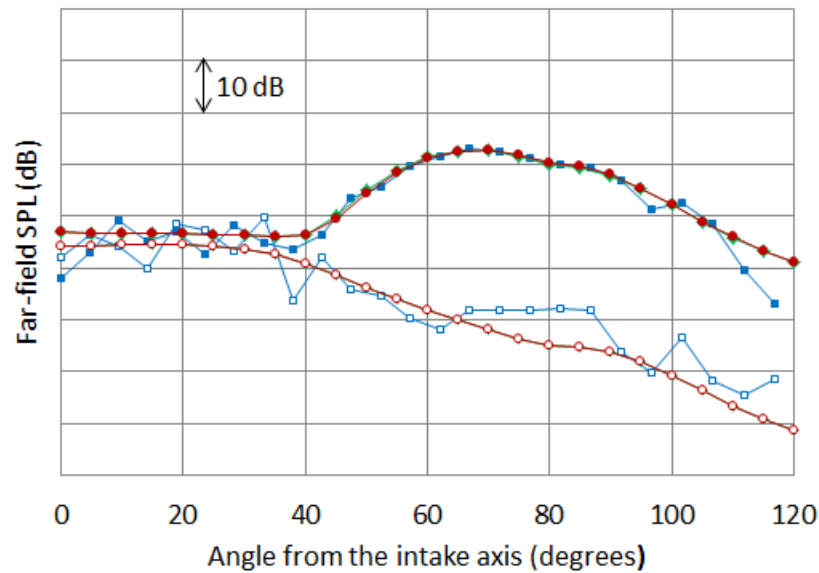
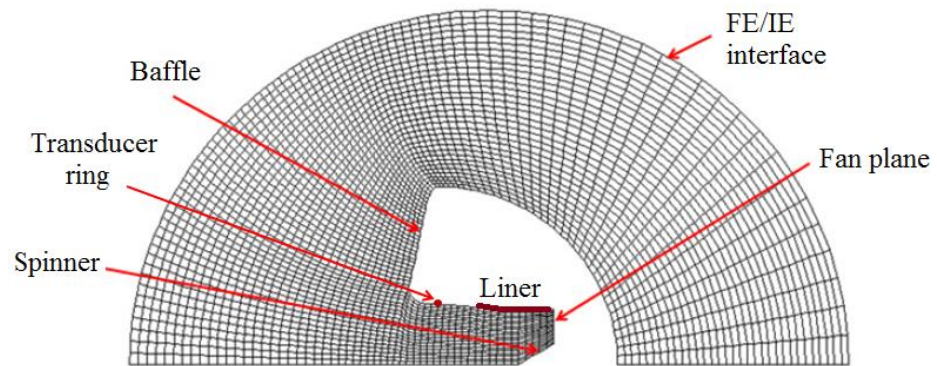

- Measured (HW)
- Predicted (HW)
- Measured (Lined)
- Predicted (Lined)

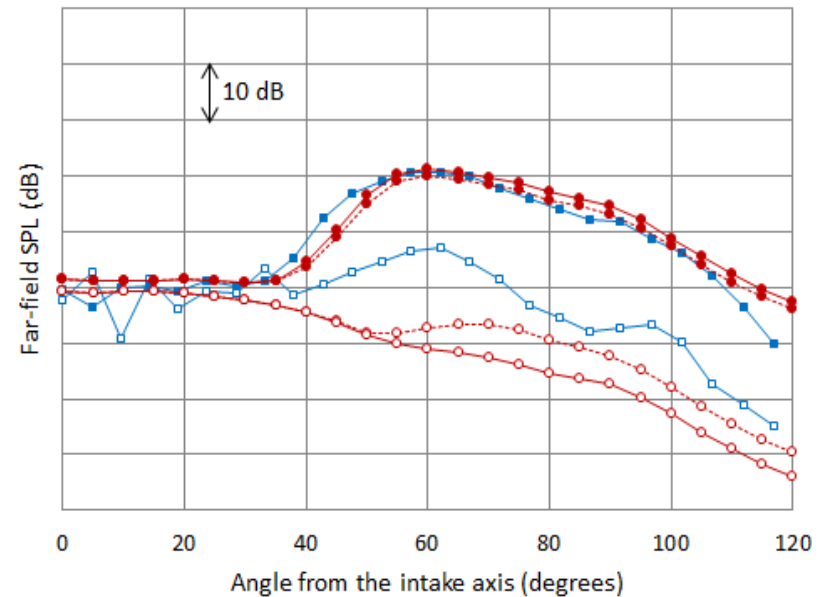

- Measured (HW)
- Predicted (HW, Linear)
- Measured (Lined)
- Predicted (Lined, Linear)
- Predicted (HW, Non-linear)
- Predicted (Lined, Non-linear)



Rolls-Royce

# Intake Lip Liner

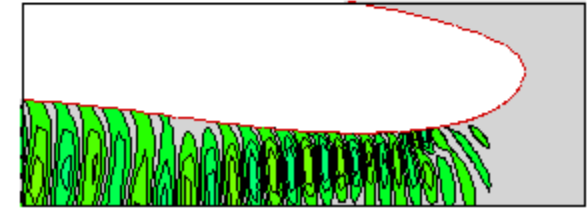
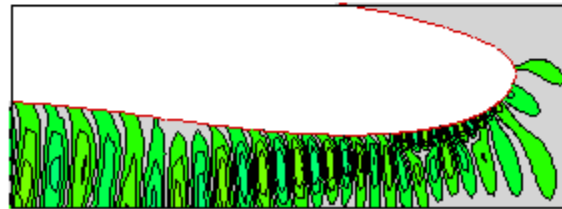
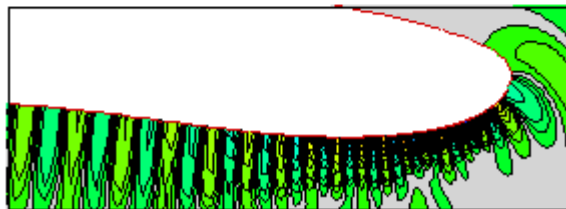
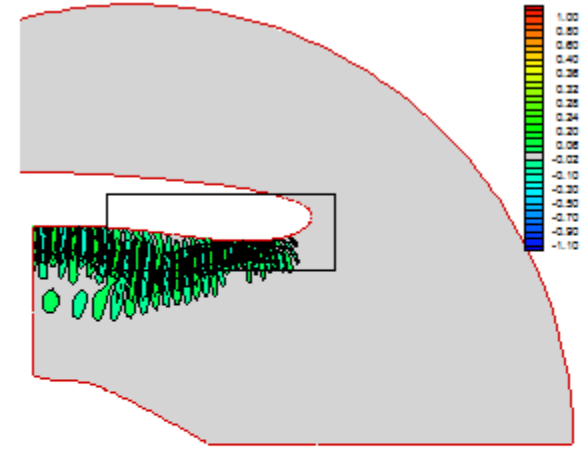
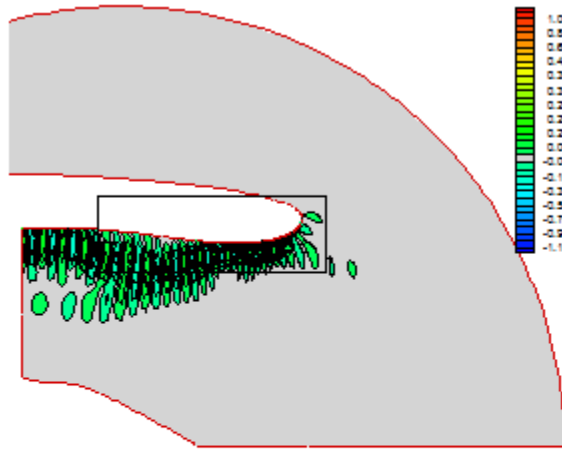
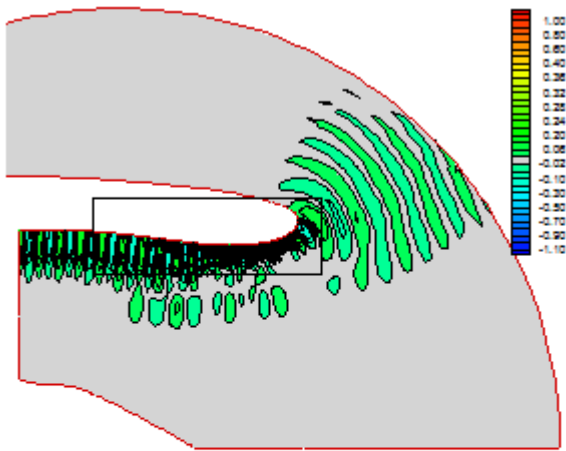

**Hard walled**

**Barrel liner**

**Lip & Barrel liners**

*With acknowledgements to ISVR*



**Rolls-Royce**

# Intake Lip Liner

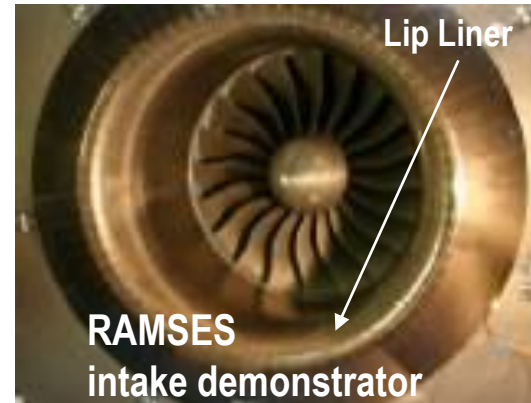

- Intake lip liners must be integrated with the anti-icing system and must not cause the intake aerodynamics to deteriorate.



# Bypass duct liners

- The three-dimensional nature of the both the duct geometry and the duct flow (including thicker boundary layers and swirl) is greatly increased, and the radiation of sound to the communities around airports is subject to refraction and frequency-broadening as it propagates across the sheared turbulent jet flow.
- Furthermore, the bypass duct is required to perform many duties:
  - enabling surface cooling in the engine
  - providing air to ventilate various zones in the engine
  - redirecting fan air for reverse thrust
  - allowing the bleeding of air from the engine core to improve engine handling.Acoustic liners must compete for space with all these features in the bypass duct, so that the area available for acoustic liners is greatly reduced.



# Multi-Disciplinary-Optimisation of Bypass Ducts

**A total-system multi-disciplinary-optimisation design approach is required. For example, highly-curved short bypass ducts bring benefits in terms of aircraft weight and fuel burn but careful design is required to reduce the noise penalty associated with the reduced acoustic liner area.**





# Bypass-Duct Propagation Model

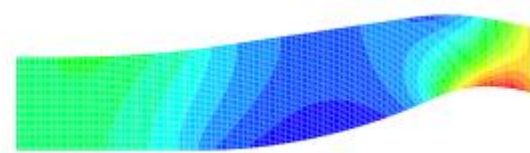
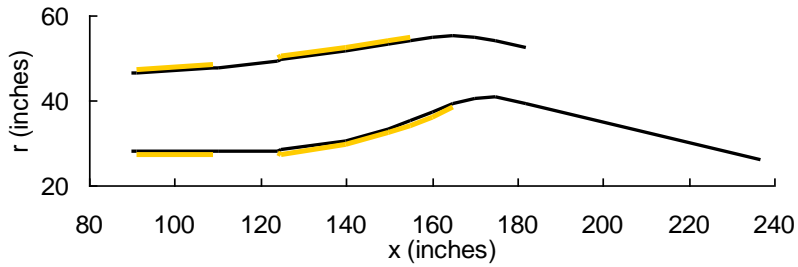

Input plane  
(OGV)

Outer/inner walls  
Hard or lined

Exhaust plane

$\rho_{mn}^+$  →  
 $\rho_{mn}^-$  ←

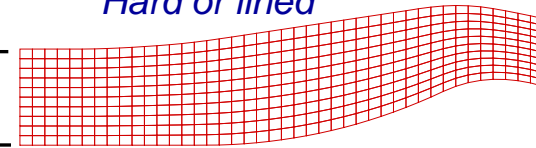

→  $\rho_{pq}^+$

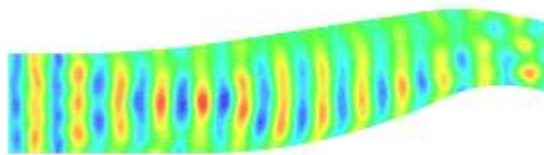

*With acknowledgements to ISVR*



Rolls-Royce

# Core-Duct Liners

- **Acoustic liners in the core duct need to survive in the very hot environment.**
- **3D curvature is large, making manufacture difficult**
- **The liners need to attenuate simultaneously both low-frequency combustion noise and high-frequency turbine noise.**
- **A total-system multi-disciplinary-optimisation design approach is required.**  
**There is a trade between penalising the turbine's weight and performance to reduce noise at source against increasing the engine weight and maintainability problems by incorporating acoustic liners in the core duct.**



# Liner Types in common use

## Single Layer Linear

Wire mesh on perforate sheet + honeycomb + hardwall backing sheet

Fibrous Face Sheet

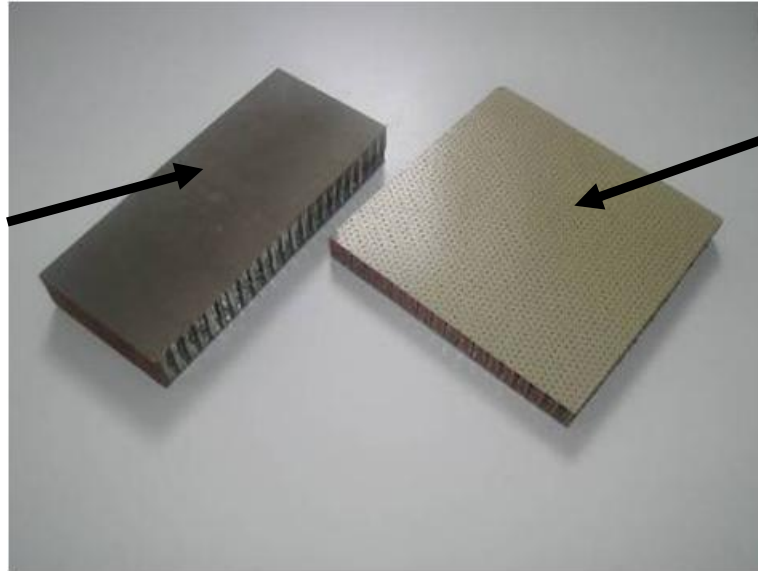
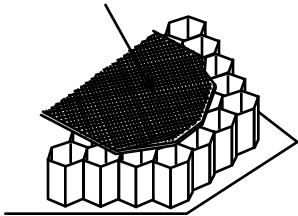

## Single Layer Perforate

Perforate sheet + honeycomb + hardwall backing sheet

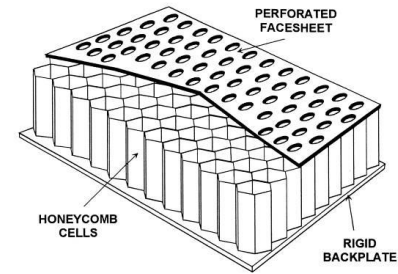

## Double layer liners

Perforate or Linear Face and Septum

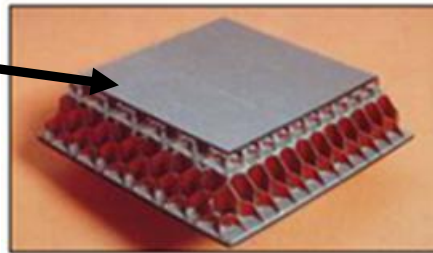
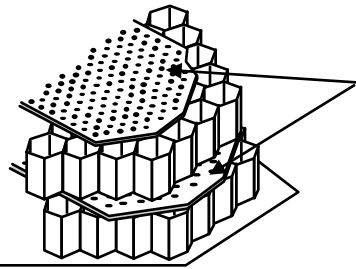

## Perforated sheets

- Punched Aluminium
- Mechanically Drilled Carbon Fibre Composites
- Laser Drilled
- Injection Moulded
- Microperforates



Rolls-Royce

# Novel Liner Materials

## Bulk Absorber materials

*Metal Casing Ceramic  
Hollow Spheres*

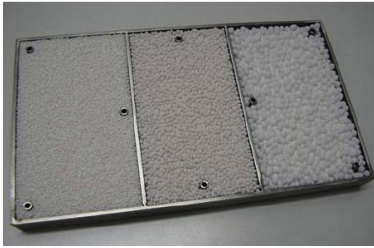

*Felt Fibre*



*Ceramic Foam*

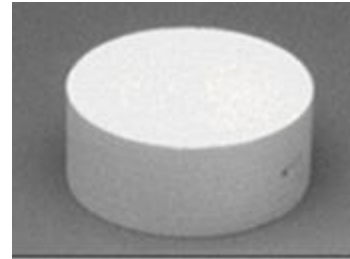

*Ceramic Fibre*



## Composite Ceramics Technology



*Metallic Plug*

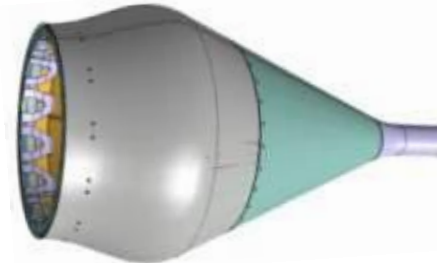

*Composite Plug*

# Novel low-frequency liners

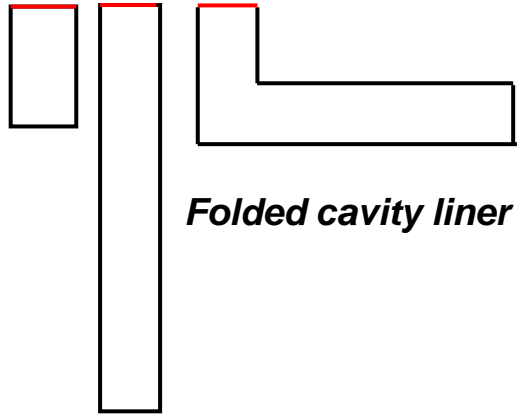

*'Special Acoustic Absorber' liner*

*With acknowledgements to EADS*

*Large Folding Cavity Plug*



*Microperforated Skin*



*Septum*



*With acknowledgements to Goodrich*



**Rolls-Royce**

# Liner rig tests

*NASA GRC 48" Fan Rig*



*AneCom 34" Fan Rig*



# Liner engine tests



Rolls-Royce/Airbus SILENCE(R)



Rolls-Royce/Boeing QTD



Rolls-Royce

# Liner Impedance Measurements

## DC Flow Resistance



## NASA Grazing Flow Impedance Tube

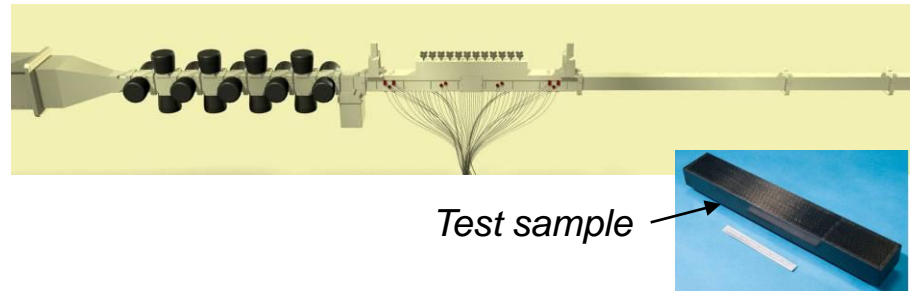

Portable Acoustic Liner Meter

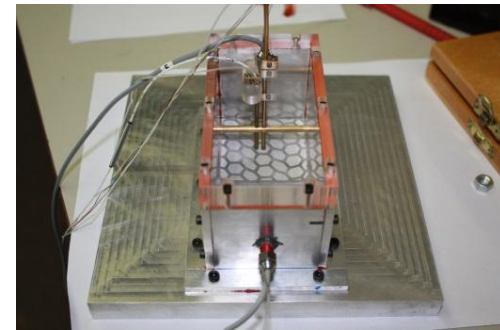

NLR In-Situ Impedance Measurements





# Liner Impedance Models

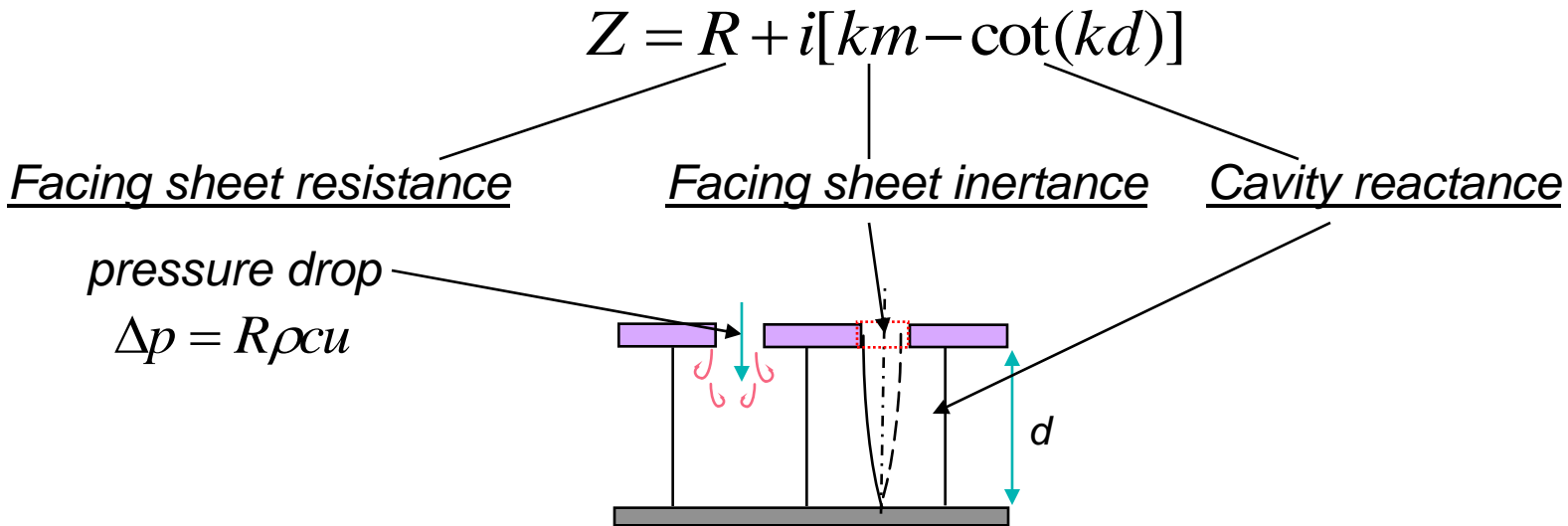

- Acoustic liner facing sheet resistance depends significantly on the manufacturing technique employed
- CFD techniques are required to inform liner acoustic impedance prediction models, in particular the resistance of facing sheets in grazing flow
- CAA techniques are required for impedance models of novel liners and for design features that result in liners being non-locally reacting (e.g. drainage slots)

# Summary

- **Aero-engine acoustic liners are an essential feature of low-noise jet aircraft, but, in addition to noise requirements, acoustic liners must satisfy many other design constraints**
- **Single-layer and double-layer liners with perforate and mesh facing sheets are standard on aero-engines, but more research is required to understand their acoustic impedance characteristics.**
- **More research is also required into novel liner designs and novel materials for acoustic liners.**
- **In order to ensure aero-engine liners are optimised, improved duct propagation prediction models are required, in particular for 3D intakes (including non-linear propagation effects) and for 3D bypass ducts (including propagation through the jet shear layer)**

