

Small Turbojet Engine MPM 20 – Simulations and Modeling

Rudolf Andoga, Ladislav Fózó, Ladislav Madarász

Department of cybernetics and artificial intelligence FEI TU Košice, Letná 9, Košice, 04001; {rudolf.andoga, ladislav.fozo, ladislav.madarasz}@tuke.sk

Abstract: Small turbojet engines represent a special class of turbine driven engines. They are suitable for scientific purposes and research of certain thermodynamic processes ongoing in turbojet engines. Moreover such engines can be used for research in the area of alternative fuels and new methods of digital control and measurement. Our research, which is also presented in this article, is headed toward these aims. We evaluate and propose a system of digital measurement of a particular small turbojet engine – MPM 20. Such engine can be considered as highly non-linear large scale system. According to obtained data and experiments we propose different approaches to modeling of the engine with use of analytic experimental and certain methods of artificial intelligence as new methods of modeling of large scale systems.

Keywords: small turbojet engine, analytic models, experimental identification, situational modeling, situational control

1 INTRODUCTION

Present state of technological development and growing complexity of systems offers many challenges and also opportunities to achieve better results. In the area of jet propulsion, terms like safety, economic profitability and at the same time high efficiency come into foreground. The traditional systems of control are becoming obsolete and a with the need to satisfy the mentioned terms it is needed to incorporate the newest technologies of control even for use in older systems to bring them up to nowadays standards. It wouldn't be economically favorable to test such technologies within expensive and also very complex big turbojet engines also with regard to safety of such testing. Therefore a special class of turbojet engines designated as small turbojet engines (usually used to start normal sized engines) can be used as an ideal test-bed for differently aimed experiments in this area. Our research is headed towards three basic aims.

1. Digital measurement of turbojet engines, which means digital real-time measurement of different state and diagnostic parameters of such engines.
2. Design and implementation of new dynamic models and control algorithms of turbo-jet engines, especially the situational control algorithms incorporating methods of artificial intelligence.
3. The aim resulting from the previous points is to explore possibilities of use of alternative fuels in turbojet engines.

All these aims comply and put emphasis mostly on safety issues of turbojet engines. Other special feature resulting from our third aim is direct use of old obsolete small turbojet engines as sources of energy with use of cheap alternative fuels. We have to take in consideration that there exist a huge number of such small turbojet engines in old aircraft that are in non flying condition. Such engines can be refurbished and used again for other purposes. All knowledge obtained by experiments with such engine can be expanded to higher levels and certain principles may be used for design of particular models and algorithms of control that could also be used in normal class turbojet engines.

2 MPM 20 ENGINE – CHARACTERISTICS AND DATA

The experimental engine MPM 20 has been derived from the TS – 20 engine, what is a turbo-starter turbo-shaft engine previously used for starting engines AL-7F. The engine has been adapted according to [10]. The engine has been rebuilt to a state, where it represents a single stream engine with radial compressor and single one stage non-cooled turbine and outlet jet. The basic scheme of the engine is shown in the figure 1.

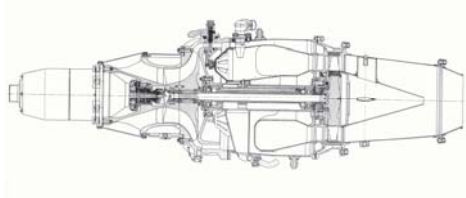

Figure 1 The scheme of MPM 20 engine [10]

In order to model the engine, it is necessary to measure its characteristics. All sensors, except fuel flow and rotations sensor, are in fact analogue which in and have voltage output. This is then digitalized by a SCXI measurement system and corresponding A/D converter and sent through a bus into computer. Every

parameter is measured at the sampling rate of 10 Hz. The data acquisition has been done in LabView environment [4].

The following parameters are measured:

- air temperature at the outlet from the diffuser of the radial compressor - t_{2c} [°C];
- gas temperatures in front of the gas turbine - t_{3c} [°C];
- gas temperature beyond the gas turbine - t_{4c} [°C];
- static pressure of air beyond the compressor p_2 [Ata];
- static pressure of gases in front of the gas turbine p_3 [Ata];
- static pressure of gases beyond the gas turbine p_4 [Ata];
- fuel flow Q_{pal} [l/min];
- thrust Th [kg];
- rotations of the turbine/compressor, n_1 [rpm].

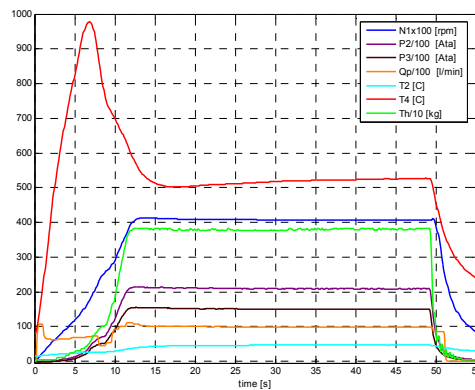

Figure 2 A scaled plot of individual characteristics of the engine

Course of every measured parameter exhibits non-linear behavior. Our aim is to create a set of dynamic models of the engine's operation in all its operational states. Usually, models of engines are created only for a certain operating point, which is usually set into the area of stable operation of an engine and is usually taken as a SISO (single input, single output) model. These models are useful for design of certain types of controllers for selected regimes of an engine. However, if we want to achieve higher quality of control, we need to design controllers with several input parameters and according models for them. Ideally we want to design a multi-parametric dynamic model in all operational states of a jet engine.

3. MPM 20 ENGINE – MODELING

In modeling we will focus on two different types of models and two different basic approaches the linear one a hybrid one. In the linear form, we will try to create models of the MPM 20 engine only in its stable operation to observe the course of basic parameters of the engine. In the second approach we will try to design modular model architecture, which will be able to simulate operation of the engine in all possible regimes. The model will be designed in terms of situational modeling approach.

3.1 Linear modeling of MPM 20

By creation of linear models we will use a state space dynamic linear model of the engine, which can be generally described in the following way:

$$\begin{aligned}\Delta\dot{q} &= A\Delta q + B\Delta u \\ \Delta y &= C\Delta q + D\Delta u\end{aligned}\tag{1}$$

where $\Delta q \in \mathbb{R}^r$ - vector of state variables;

$\Delta u \in \mathbb{R}^m$ - vector of input (control) variables;

$\Delta y \in \mathbb{R}^s$ - vector of output (observed) variables;

$A \in \mathbb{R}^{r \times r}$ - matrix of dynamics;

$B \in \mathbb{R}^{r \times m}$ - input matrix;

$C \in \mathbb{R}^{s \times r}$ - output matrix;

$D \in \mathbb{R}^{s \times m}$ - matrix of direct relations coefficients.

For purpose of turbojet engine modeling we consider the dimensions of individual matrixes can be set as follows:

r – number of compressor stages, m – number of control parameters, s is the number of observed variables. For the purpose of MPM 20 engine modeling we will consider the following variables:

State variable

- Δn - difference of rpm's of the radial compressor [rpm].

Control variable

- $\Delta d_{.5}$ - difference of diameter of the exhaust nozzle [m].
- ΔQ_{pal} - difference of fuel flow [l/min]

Observed variables

- ΔT_{4c} - difference of gases temperature on the outlet of the turbine [°C];
- Δp_{2c} - difference of pressure on the compressor [Ata];
- ΔF_t - difference of thrust of the engine [kg].

Further we can also describe a turbojet engine in terms of state space model as following for control variable of fuel flow:

$$\begin{aligned}\Delta \dot{n} &= A\Delta n + B\Delta Q_{pal} \\ \Delta y &= C\Delta n + D\Delta Q_{pal}\end{aligned}\quad (2)$$

and for control variable of exhaust nozzle diameter:

$$\begin{aligned}\Delta \dot{n} &= A\Delta n + B\Delta d_{-5} \\ \Delta y &= C\Delta n + D\Delta d_{-5}\end{aligned}\quad (3)$$

The model describes the basic dynamic properties of the engine in terms of differences from stable regime of operation. After using a method of linear approximation from measured data of the engine we are getting a set of differential linear equations describing the engine:

$$\begin{aligned}\Delta \dot{n} &= -5,9891\Delta n - 5,3315e + 006\Delta d_{-5} \\ \Delta T_{4c} &= 9,1372e - 004\Delta n + 194,42\Delta d_{-5} \\ \Delta p_{2c} &= 1,96e - 004\Delta n + 70,2465\Delta d_{-5} \\ \Delta F_t &= 4,9533e - 004\Delta n - 480,60\Delta d_{-5}\end{aligned}\quad (4)$$

and for Q_{pal} control variable we are getting the following set:

$$\begin{aligned}\Delta \dot{n} &= -0,6494\Delta n + 2.2398e + 004\Delta Q_{pal} \\ \Delta T_{4c} &= 0,0596\Delta n - 7,003674e + 002\Delta Q_{pal} \\ \Delta p_{2c} &= 2,0019e - 005\Delta n + 1,9328\Delta Q_{pal} \\ \Delta F_t &= 4,6227e - 005\Delta n + 61,190\Delta Q_{pal}\end{aligned}\quad (5)$$

Simulations with the model are shown in the following figures.

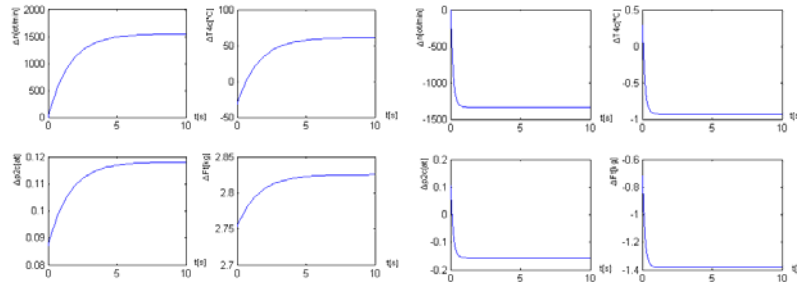

Figure 3 a) Differences of the observed parameters of the engine in response to fuel flow step (left)
 b) Differences of the observed parameters of the engine in response to exhaust nozzle diameter step

Although a first order linear dynamic model can simulate some basic dynamic properties of the MPM 20 engine with mean average errors about 280 rpm (fig.5) and can be used to design basic controllers such as constant rpm regulator, they are not sufficient to capture properties of a jet engine for design of efficient advanced control algorithms.

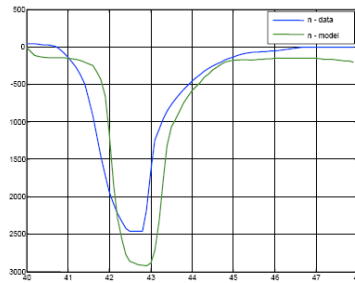

Figure 4 Simulation of a linear model against predicted data

3.2 The analytical approach in modeling of MPM 20

Static and dynamic properties of turbojet engines (MPM 20) can also be described by a mathematical model of operation single stream engine under equilibrium or non-equilibrium conditions. This will allow to model the thrust, fuel consumption, pressures and temperatures of the engine by different altitudes and velocities in the chosen cuts of the engine. The steady operation of the engine is such a regime, where in every element of the engine same thermodynamic processes are realized. Operation of an engine in its steady operation can be described by:

1. algebraic equations of balance of mass flow of working materials through nodes of the engine, equations of output balance, equations of regulation rules and equations describing particular oddities of an engine. A system of equations expresses that for given outer

conditions of operation of an engine, characteristics of all nodes of an engine and preset values of control parameters (fuel supply, cross section of the output nozzle, angle of compressor blades), operation of the engine will settle itself on one and only one regime [18]

2. graphically by utilization of knowledge of characteristics of all parts (output, compressor, turbine, etc) of the engine and their preset curves of joint operations (e.g. lines of stable ratios of T_{3c}/T_{1c} in compressor). Designation of all curves of the engine is done in a way that we will try to fulfill continuity conditions for all parts of the engine and characteristics of all these parts are given. These characteristics can be found by direct measurement, computation, etc.

Any regime of the turbojet engine has to fulfill the continuity equation which designates dependencies between mass flow of air through the compressor, turbine, combustion chamber and exhaust system:

$$Q_{VS} = Q_k = Q_{SK} = Q_T = Q_{tr} = Q \quad (6)$$

and a condition of no distortion of the shaft

$$n_k = n_T = n \quad (7)$$

where

- Q_{VS} – mass flow of air through input system,
- Q_k – mass flow of air through the compressor
- Q_{SK} – mass flow of air through combustion chamber,
- Q_T – mass flow of gases through the turbine,
- Q_{tr} – mass flow of gases through exhaust nozzle,
- n_k – revolutions of compressor,
- n_T – revolutions of turbine.

Another condition for steady operation of the engine has to be fulfilled – the engine doesn't change its revolutions in time.

$$\frac{dn}{dt} = 0 \quad (8)$$

This condition will be fulfilled when output of the turbine will be the same as output taken by the compressor and accessories of the engine

$$W_{KC} = \eta_m W_{TC} \quad (9)$$

where

- η_m – mechanical effectiveness of the engine,
- W_{KC} – technical work of the compressor,
- W_{TC} – technical work of the turbine.

The curve of stable operation is shown in the figure 6a. A detailed algorithm of designation of operational points of steady operation of a single stream engine is described in [18].

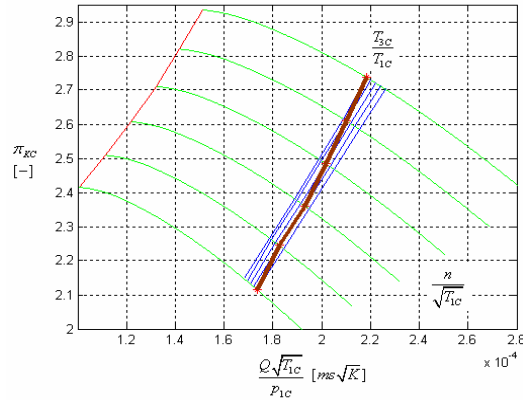

Figure 5 The curve of steady state of operation of the MPM 20 engine

Non steady operation of an engine is a regime of its operation, where in every element of the engine time changing thermodynamic processes occur. Function of the engine in such non steady regimes can be described by a system of differential and algebraic equations. Such system of equations describes transient processes by change of regime of the engine, when thrust lever is moved or other change of flight regime occurs.

Such non-steady regime occurs when work of the turbine and compressor isn't equal, this means that rotation moments of the turbine M_T and compressor M_K aren't equal. Acceleration of the engine is dependant upon this difference:

$$M_T - M_K - M_{ag} = J \frac{d\omega}{dt} \quad (10)$$

where

- $\frac{d\omega}{dt}$ – angular acceleration of the engine,
- J – moment of inertia of all rotating masses reduced to the shaft of the engine,
- M_{ag} – moment needed for actuation of aggregates and overcoming of friction.

As the angular velocity is given by the equation $\omega = \frac{\pi n}{30}$ and output is given by

equation $P = M\omega$ and incursion of mechanical effectiveness, the basic equation of non-stable operation of the engine is obtained:

$$P_T \eta_m - P_k = J \frac{\pi^2}{900} n \frac{dn}{dt} \quad (11)$$

Stable operation of the engine is then computed which gives the initial conditions. Differences of revolutions are then computed in a given time space Δt and we repeat this algorithm until the end of the transient process (fig. 7).

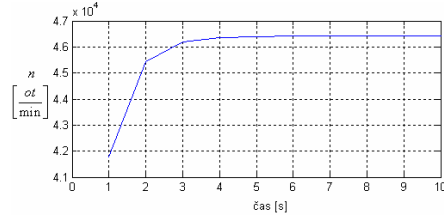

Figure 6 The curve of non steady state of operation of the MPM 20 engine (acceleration)

Analytic mathematical model of the engine is based on physical rules which characterize properties and operation of different nodes of the engine, thermodynamic and aerodynamic processes obtained by temperature cycle. While we have to take in account range of operation of turbojet engines which give changes of thermodynamic properties of working material.

3.3 Situational model architecture

Individual dependencies of parameters of a turbojet engine are more complex than they can be depicted by a state space model. We can see a general dependence of T_{2c} , T_{4c} , P_{2c} , n parameters on Q_{pal} parameter in figure 7. So in this case it is difficult distinguish state parameters from observed parameters. The other arising problem is that these dependencies are not stationary and are changing during course of turbojet's engine operation. Therefore we have to decompose the operation of the engine into some operational regimes, which will represent situational frames and design at first semiotic models of individual parameter dependencies as shown in the figure 6. In such case it isn't possible to easily set operating points in multi-dimensional non linear parametric space. The operating point will lie on a functional of the following parameters:

$$O_p = f(Q_p, NI, T4, T2, P2) \quad (6)$$

To decompose the model into subspaces, we will use the methodology of situational modeling and decompose the model into sub-models representing certain operating points of the engine.

$$O_{pi} = f_i(NI, T4, T2, P2), i=1...n \quad (7)$$

where n is the regimes count. This decomposition can be done by expert knowledge or with use of some clustering algorithm. We propose the decomposition of the model into a set of three operating points ($n=3$), or in terms of situational modeling into three distinct situations [13]. That is the startup of the engine, stable operation of the engine and its shutdown. Every situational model is further decomposed into a set of non equivalent sub-models, which are interconnected according to the basic physical dependencies in the engine and are treated as black box systems. Every of these sub-models is then represented by a neural network or fuzzy inference system, which models the individual parameter

dependencies and further decomposes the operating points into local operating points which are then represented as local neural or fuzzy models. Furthermore all models have to be put in an adaptive structure that will be able to decide, which model to use for certain situational frame. The modular architecture of such system is shown in the figure 7. A classifier in the form of neural network represents the gate which gates outputs of individual models to give a correct prediction. Use of this model allows us to simulate whole operation of the engine with also highly non-linear atypical situations such as startup and run down of the engine. The model has only a single input parameter in the form of fuel flow input Q_{pal} .

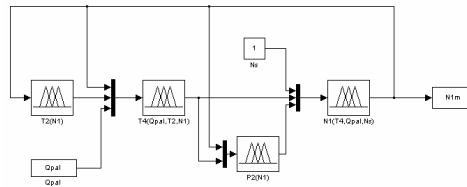

Figure 7 The basic scheme of the model of MPM20 engine.

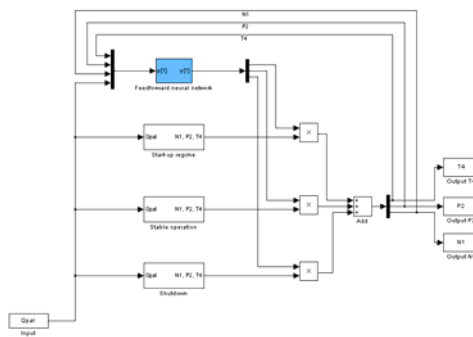

Figure 8 The basic scheme of the situational model of the engine

The inputs of the classifier neural network are state variables resulting from the model, the only input to the model is the fuel flow parameter. The output of the network will be defined as a vector:

$$O_u = [x_1, \dots, x_n] \quad (8)$$

where n is the number of situational model frames and $x_i = \{0; 1\}$.

3.4 Situational model simulations

We can evaluate the situational model in terms of simulating the start-up of the engine, its stable regime of operation and its run down, together with the whole

operation. The figure 7 shows the plot of rpm's of the engine during its startup with three different startup levels of fuel flow input. The individual sub-models for this frame [14] are in the form of neural networks trained by scaled conjugate gradient algorithm with time delayed inputs [15]. Figure 8 shows simulation of a stable operation of the engine with models in the form of TSK fuzzy inference systems(FIS) [17].

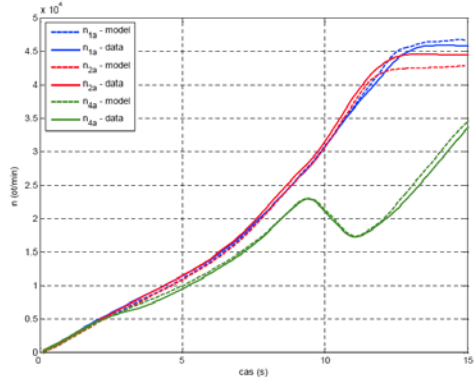

Figure 9 The results of the start-up model for different levels of input signal

The results of the dynamic model are shown in the figure 7. Mean average of absolute error between the model and the measured data for 3 exemplar different levels of fuel flow input MAE = 0.2%.

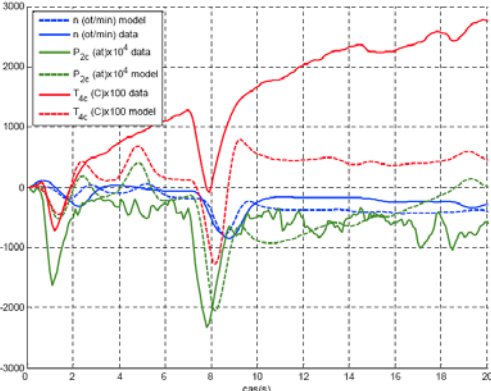

Figure 10 One run of the engine by simulation of differences of all variables in the stable regime

The problematic area in this case is temperature T_{4c} , because by use of the FIS TSK model we aren't able to simulate overheating of the engine as time of operation isn't the input parameter.

Simulation of the whole operation of MPM20 engine is shown in the figure 9. The errors of simulation of 15 different measured runs of the engine in its whole operation are shown in the following table. The table shows means of mean average (MAE) and maximum absolute error (MAAE).

table 1. MAE and MAAE errors of the model

Parameter	MAE _{p=1..15}	MAAE _{p=1..15}	MAE _{p=1..15} (%)	MAAE _{p=1..15} (%)
n (ot/min)	67	275	0.14	0.61
T_{4c} (°C)	13	56	1.1	2.7
P_{2c} (At)	0.065	0.071	1.7	1.88

We can see that the maximum error for MAE is about 1.7% in the whole dynamic range and MAAE 2.7% which gives way more accurate predictions than linear models.

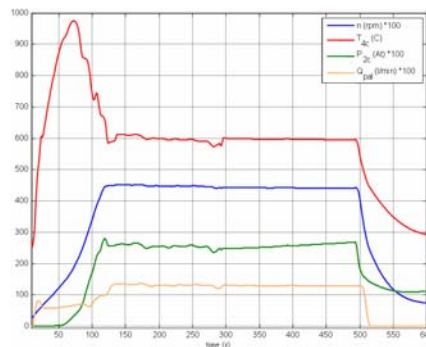

Figure 11 One run of the engine by simulation of differences of all variables in the stable regime

Conclusions

The object of a small turbojet engine MPM 20 gives us an ideal test bed for research of methods in the areas of non-linear dynamic systems modeling and design of advanced control algorithms. Further research will be done in the area of situational modeling that will be headed towards broadening of input parameters of the situational model of the engine and further refinement of situational classes' designation. In this area we will be aimed at use of automatic algorithms to find boundaries between situational frames within multivariate space of parameters contrary to their setting by an expert.

One of the methods for achieving the aim to find precise boundaries between situational frames will be the inclusion of data of magnetic aura of the MPM 20 engine during its different regimes of its operation. The data will represent multivariate space of parameters of the engine.

Acknowledgement

The work was supported by project: VEGA no. 1/0394/08 – Algorithms of situational control and modeling of large scale systems.

References

- [1] Beneš, J, *Teorie systémů (řízení komplexů)*, 200 pp. Academia, nakladatelství ČSAV, 1974.
- [2] Lazar, T. et al., *Tendencie vývoja a modelovania avionických systémov*, Ministerstvo Obrany SR, pp.160, 2000, ISBN 80-8842-26-3.
- [3] Madarász, L., Andoga, R., Development and Perspectives of the Situational Control of the Complex Systems. *Proceedings of the microCAD2004 International Scientific Conference*, March 18-19, 2004, University of Miskolc, Hungary, pp.73-80, ISBN 963 661 615 9
- [4] Madarász, L., Andoga, R., The Proposal of use of Hybrid Systems in Situational Control of Jet Turbocharger Engines, *In Proceeding of SAMI 2005 Conference*, January 21-22.2005, Slovakia, pp. 479, ISBN 963-7154-35-3.
- [5] Madarász, L., Holečko, P, Methodology of Situational Control Creation and its Applications. *1st IFAC Workshop, New Trends in Design of Control Systems*, pp. 155 - 162. Smolenice, 1994.
- [6] Madarász, L., *Inteligentné technológie a ich aplikácie v zložitých systémoch*, Vydavateľstvo Elfa, s.r.o., TU Košice, 349 pp., ISBN 80 – 89066 –75 - 5, 2004
- [7] Madarász, L., *Metodika situačného riadenia a jej aplikácie*, 212 pp. ISBN 80 – 88786 – 66 – 5, Elfa Košice, 1996.
- [8] Pospelov, D.A, *Situacionnoje upravlenije. Teoria i praks. Nauka*, Moskva, 1986., 284 pp
- [9] Ružek, J., Kmoch, P., *Teorie leteckých motoru I.*, 373 pp, 1979.
- [10] Hocko, M., *Hodnotenie stavu LTKM na základe zmeny termodynamických parametrov.*, Dissertation Theses, Vojenská Akadémia Gen. M.R., Štefánika, Košice, 2003.
- [11] Horváth L., Rudas I. J., *Modeling and Problem Solving Methods for Engineers*, ISBN 0-12-602250-X, Elsevier, Academic Press, 2004
- [12] Horváth L., Rudas I. J., *Intelligent Engineering Modeling by Active Models, In Intelligent Systems at the Service of Mankind, Volume 1*, 2004, pp-363-371 Folyóiratcikkek
- [13] Andoga, R., Madarász, L., FIZI, L.: Situational modeling and control of a small turbojet engine MPM 20, IEEE International Conference on Computational Cybernetics, 20.-22. August, 2006, Tallinn, Estonia, ISBN. 1-4244-0071-6, pp. 81-85.
- [14] Andoga, R.: Hybrid methods of situational control of complex systems, Dissertation Thesis, Technical University of Košice, 2006, pp.120.
- [15] Moller, M. F., A scaled conjugate gradient algorithm for fast supervised learning, *Neural Networks*, vol. 6, pp. 525-533, 1993.
- [16] Harris, Ch., Hong, X., Gan, Q.: Adaptive Modelling, Estimation and Fusion from Data, Springer, ISBN 3-540-42686-8, pp. 323, 2006.
- [17] Zilberstein, S.: Using Anytime Algorithms in Intelligent Systems. *AI Magazine*, 17(3):73-83, 1996.
- [18] J. Ružek, P. Kmoch: *Teorie leteckých motoru, časť II.*, VA AZ, 1983