

AD-A250 424



AD E 951 808

2

TECHNICAL REPORT RD-PR-91-17

INTRODUCTION TO ROCKET PROPULSION

J. Michael Lyon
Propulsion Directorate
Research, Development, and Engineering Center

December 1991

DTIC
SELECTED
MAY 14 1992
S B D



U.S. ARMY MISSILE COMMAND

Redstone Arsenal, Alabama 35898-5000

Approved for public release; distribution is unlimited.

92-12550



92 5 11 033

DESTRUCTION NOTICE

FOR CLASSIFIED DOCUMENTS, FOLLOW THE PROCEDURES IN DoD 5200.22-M, INDUSTRIAL SECURITY MANUAL, SECTION II-19 OR DoD 5200.1-R, INFORMATION SECURITY PROGRAM REGULATION, CHAPTER IX. FOR UNCLASSIFIED, LIMITED DOCUMENTS, DESTROY BY ANY METHOD THAT WILL PREVENT DISCLOSURE OF CONTENTS OR RECONSTRUCTION OF THE DOCUMENT.

DISCLAIMER

THE FINDINGS IN THIS REPORT ARE NOT TO BE CONSTRUED AS AN OFFICIAL DEPARTMENT OF THE ARMY POSITION UNLESS SO DESIGNATED BY OTHER AUTHORIZED DOCUMENTS.

TRADE NAMES

USE OF TRADE NAMES OR MANUFACTURERS IN THIS REPORT DOES NOT CONSTITUTE AN OFFICIAL ENDORSEMENT OR APPROVAL OF THE USE OF SUCH COMMERCIAL HARDWARE OR SOFTWARE.

UNCLASSIFIED

SECURITY CLASSIFICATION OF THIS PAGE

REPORT DOCUMENTATION PAGE

Form Approved
OMB No. 0704-0188
Exp. Date: Jun 30, 1986

1a. REPORT SECURITY CLASSIFICATION
UNCLASSIFIED

1b. RESTRICTIVE MARKINGS

2a. SECURITY CLASSIFICATION AUTHORITY

3. DISTRIBUTION/AVAILABILITY OF REPORT
Distribution A
Approved for public release; distribution is unlimited

2b. DECLASSIFICATION/DOWNGRADING SCHEDULE

4. PERFORMING ORGANIZATION REPORT NUMBER(S)
TR-RD-PR-91-17

5. MONITORING ORGANIZATION REPORT NUMBER(S)

6a. NAME OF PERFORMING ORGANIZATION
Propulsion Directorate
RD&E Center

6b. OFFICE SYMBOL
(if applicable)
AMSMI-RD-PR-S

7a. NAME OF MONITORING ORGANIZATION

6c. ADDRESS (City, State, and ZIP Code)
Commander, U. S. Army Missile Command
ATTN: AMSMI-RD-PR-S
Redstone Arsenal, AL 35898-5252

7b. ADDRESS (City, State, and ZIP Code)

8a. NAME OF FUNDING/SPONSORING ORGANIZATION

8b. OFFICE SYMBOL
(if applicable)

9. PROCUREMENT INSTRUMENT IDENTIFICATION NUMBER

8c. ADDRESS (City, State, and ZIP Code)

10. SOURCE OF FUNDING NUMBERS
PROGRAM ELEMENT NO. PROJECT NO. TASK NO. WORK UNIT ACCESSION NO.

11. TITLE (Include Security Classification)
Introduction to Rocket Propulsion

12. PERSONAL AUTHOR(S)
J. Michael Lyon

13a. TYPE OF REPORT
Summary

13b. TIME COVERED
FROM _____ TO _____

14. DATE OF REPORT (Year, Month, Day)
Dec 1991

15. PAGE COUNT
234

16. SUPPLEMENTARY NOTATION

17. COSATI CODES		
FIELD	GROUP	SUB-GROUP

18. SUBJECT TERMS (Continue on reverse if necessary and identify by block number)
Rockets, Propellant
Performance, Design

19. ABSTRACT (Continue on reverse if necessary and identify by block number)
The design process for solid propellant rocket motors is presented in an introductory text suitable for professional reference as well as for instruction at the high school senior through college junior level. Beginning with a brief history of rocketry and a short discussion of the basic properties of matter, the text progresses through the development of the governing laws of rocket propulsion and utilization of important propulsion theories and equations. Design considerations for various motor components (propellants, grain, and inert hardware) are presented. Performance prediction using computers and instrumentation and testing are discussed. Numerous examples and problems are provided.

20. DISTRIBUTION/AVAILABILITY OF ABSTRACT
 UNCLASSIFIED/UNLIMITED SAME AS RPT. DTIC USERS

21. ABSTRACT SECURITY CLASSIFICATION
UNCLASSIFIED

22a. NAME OF RESPONSIBLE INDIVIDUAL
J. Michael Lyon

22b. TELEPHONE (Include Area Code)
(205) 876-3225

22c. OFFICE SYMBOL
AMSMI-RD-PR-S

TABLE OF CONTENTS

	<u>Page</u>
INTRODUCTION TO ROCKET PROPULSION	vi
CHAPTER I A THOUSAND YEARS OF ROCKETRY	1
CHAPTER II PROPULSION DEVICES	12
2.1 Duct Jet Propulsion Devices	14
2.2 Rocket Propulsion Devices	15
CHAPTER III PROPERTIES OF MATTER	24
3.1 Pressure	25
3.2 Density	32
3.3 Temperature	32
3.4 Heat	35
3.5 Viscosity	39
3.6 Momentum	39
3.7 Ideal Gas	40
CHAPTER IV THE GOVERNING LAWS OF ROCKET PROPULSION	46
4.1 Newton's First Law of Motion	46
4.2 Newton's Second Law of Motion	48
4.3 Newton's Third Law of Motion	49
4.4 Conservation of Mass (Continuity Equation)	56
4.5 Bernoulli's Equation	59
4.6 Conservation of Momentum	63
4.7 First Law of Thermodynamics (Law of Conservation of Energy)	65
4.8 The Second Law of Thermodynamics	70
4.9 Bernoulli Revisited	75

	<u>Page</u>
CHAPTER V PROPULSION EQUATIONS	77
5.1 Ideal Rocket	77
5.2 Thrust Equation	89
5.3 Total Impulse	95
5.4 Specific Impulse	96
5.5 Burning Rate and Motor Pressure	97
5.6 Equilibrium Pressure	99
5.7 Ideal Burnout Velocity	102
5.8 Temperature Sensitivity	103
5.9 Nozzle Divergence Loss	105
5.10 Optimum Thrust	106
5.11 The Effect of Ambient Pressure on Nozzle Flow	107
CHAPTER VI DESIGN TOPICS	108
6.1 Mass Addition	108
6.2 Erosive Burning	113
6.3 Transient Operation	115
6.4 Nozzle Area Variation	117
6.5 Miscellaneous Losses	117
CHAPTER VII PROPELLANTS	119
7.1. Basic Chemicals	123
7.2 Homogeneous Propellants	126
7.3 Nonhomogeneous (Composite) Propellants	131
7.4 Burning Rate Determination	138

	<u>Page</u>
CHAPTER VIII GRAIN DESIGN	143
8.1 Cylindrical Grains	144
8.2 Internal Burning Tube	144
8.3 Neutral Grains	145
8.4 Noncircular Perforations	146
8.5 Dual Thrust Grains	149
CHAPTER IX HARDWARE COMPONENT DESIGN	151
9.1 Chamber and Nozzle Design	151
9.2 Liners, Insulators, and Restrictors	158
9.3 Igniters	159
CHAPTER X PREDICTION	161
10.1 First-Order Preliminary Design (FOPD)	162
10.2 Motor Ballistics (MBAL)	163
CHAPTER XI TESTING	177
11.1 Nondestructive Tests	178
11.2 Destructive Tests	181
11.3 Instrumentation	187
11.4 Data Analysis	190
BIBLIOGRAPHY	199
APPENDIX A	A-1
APPENDIX B PROBLEM SET	B-1

INTRODUCTION TO ROCKET PROPULSION

Objectives of the Text

In recent years, we have observed the need for a basic text which would set forth the fundamental aspects of solid rocket propulsion and provide a useful resource for engineers and scientists.

By studying this text, you are expressing your desire to learn more of the fundamental concepts associated with propulsion systems in general and rocket propulsion in particular. This book has been prepared to meet your challenge.

In this "Introduction to Rocket Propulsion", we'll begin with a brief history and overview of propulsion systems. We will then discuss matter and its properties (particular emphasis will be placed on gases). We'll develop equations for gas flow in pipes and nozzles which will allow you to predict the behavior of a solid rocket.

Our overall objective is to provide you with (1) a working knowledge of solid rocket motors – their design and performance and (2) an understanding and appreciation of careers in engineering – the "pulling together" of numerous and varied disciplines to achieve a stated goal.

You will notice that throughout this text, the English system of units (lbs, in, etc) is used. The metric system is a more logical choice, however, the propulsion community in the U.S. is still firmly entrenched in the English system.

Numerous exercises and solutions are provided. These will serve to both reinforce topics in the text discussion and provide practice in using the English system of units.

Accession For	
NTIS GRA&I	<input checked="" type="checkbox"/>
DTIC TAB	<input type="checkbox"/>
Unannounced	<input type="checkbox"/>
Justification	
By	
Distribution/	
Availability Codes	
Dist	Avail and/or Special
A-1	



CHAPTER I A THOUSAND YEARS OF ROCKETRY

The rocket is a reaction device which works in accordance with Sir Isaac Newton's Third Law of Motion:

For every action there is an equal and opposite reaction.

A rocket can be compared to a continuously firing machine gun mounted on the rear of a row-boat. As the gun is fired to the rear, the recoil from the gun is transmitted to the boat, causing it to move forward a little. In a rocket, the "bullets" are minute particles that are thrown out through a nozzle as a propellant is burned in a chamber. The discharge of these particles makes the rocket fly in the opposite direction. The reaction principle was known long before a true rocket was invented. In his *Noctes Atticae* (Attic Nights), Alus Gellius described the ancient pigeon of Archytis, dating back to about 360 B.C. Hanging from a string, the pigeon was made to move by steam blowing from small exhaust ports.

A more sophisticated device was the reaction wheel, or aeolopile, developed by Hero, a Greek resident of Alexandria. He lived about the time of Christ, but the exact dates are unknown. The aeolopile was, in effect, a primitive steam turbine, although apparently no practical use was made of the device. It was constructed of a hollow globe, which was allowed to spin on two arms. One arm was hollow, permitting steam to pass through it into the globe. On opposite sides of the globe, were two bent tubes whose open ends were pointed in opposite directions. As the steam escaped through these tubes, the globe revolved.

The precise origin of the rocket itself is lost in the shadow of time. Almost all Western and Oriental histories credit the Chinese with the invention, but sources are seldom given for this claim, making it difficult to accept or reject. Part of the trouble in settling the question is caused by lack of clarity in descriptions of ancient weapons; often, it is difficult to tell from a vague description whether a projectile was powered by a motor or merely carried powder or material that burned.

Most authorities believe the invention of rockets is tied inextricably to the discovery of black powder which served as the first rocket propellant. The best available evidence, including both early Chinese and Europeans who visited China, indicates the Chinese certainly were the first to use black powder and, therefore, probably the first to use rockets as well.

The ingredients of black powder – technically, it should not be called gunpowder because guns came later, but it usually is – are charcoal, sulfur, and saltpeter. These have been known in China for perhaps two thousand years

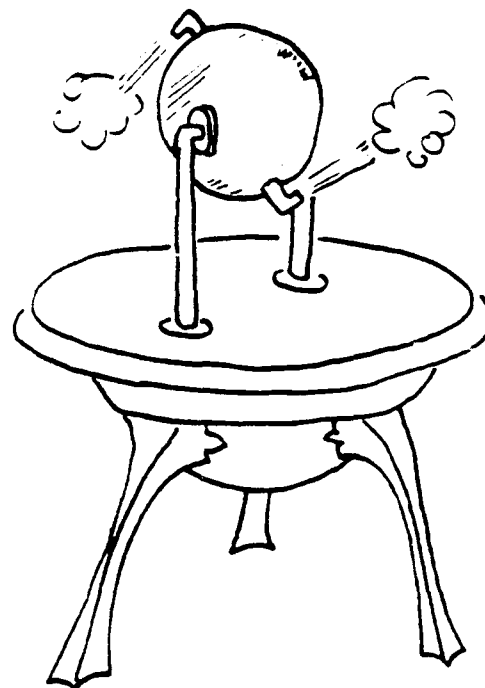

Rocketry History

– charcoal since the very earliest times, and sulfur and saltpeter at least since the sixth century A.D., probably as far back as the first century B.C.

That the ingredient saltpeter is definitely of Chinese origin is indicated by the names given to this material by the Arabs, who called it “Chinese snow”, and the Persians, who called it “salt from China.” The three ingredients were known in China for many centuries, however, before they were combined into black powder.

The first firecrackers may have appeared in the Chin Dynasty (221 – 207 B.C.) or during the Han Dynasty (206 B.C. – A.D. 220). According to the Han work Shen I Ching (Classic of Strange Spiritual Manifestations), what was called Pao Chu, or “bursting bamboo”, was put into the fire, producing a noise that “frightened the spirit of the mountain.” Earlier Chin works speak of the “bamboo bursting” and that the “cracking of bamboo is like the roar of the wild animals.” It is not known definitely that the bursting of the bamboo was caused by the explosion of black powder.

Other early Chinese writings also contain references to what was either black powder or a similar substance. A work on medicine written by Sun Saumiso, who died in A.D. 682, describes experiments on fu huo fa (calcination), including one in which the author combined equal amounts of saltpeter and sulfur, added some acacia seeds, and lit the resulting powder.

During the Northern Sung Dynasty (A.D. 960 – 1126), the term Pao Chang was used to describe firecrackers, which are believed to have contained black powder. Another term, Yen Huo, meaning firework, is said to have originated during the reign of Yang Ti (A.D. 605 – 616). Fireworks became popular during the Tang Dynasty (A.D. 618 – 907) and were perfected by the time of the Northern Sung Dynasty.

By 1045, twenty-one years before William the Conqueror invaded Saxon England, there is no doubt the Chinese were well acquainted with black powder. The Wu-ching Tsung-yao (Complete Compendium of Military Classics) published that year contains many references to the subject.

The Complete Compendium indicated that black powder, and possibly black-powder rockets, were used extensively during the Sung Dynasty, a period of brilliant cultural activity lasting from A.D. 960 to 1279. The book gives this formula for making gunpowder:

1 chin 14 ounces of sulfur, together with 2 1/2 chin of saltpeter, 5 ounces charcoal, 2 1/2 ounces of pitch, and 2 1/2 ounces of dried varnish are powdered and mixed. Next, 2 ounces of wax are also mixed to form a paste. Then these ingredients are all mixed together, and slowly stirred. The mixture is then wrapped in a parcel with five layers of paper, which is fastened with hempen thread, and some melted pitch and wax is put on the surface.

A French missionary, Father Joseph Marie Amiot, observed that firearms were known in China from the beginning of the Christian era. Father Amiot also described a fire-arrow to which an early type of rocket may have been attached. According to Amiot:

“The tube where the powder is placed must be extremely straight, should be only four inches long, and its end should be two inches from the fire. An arrow thus launched is equivalent to a very powerful gunshot.”

He does not say, however, when this fire-arrow was introduced.

Rocketry History

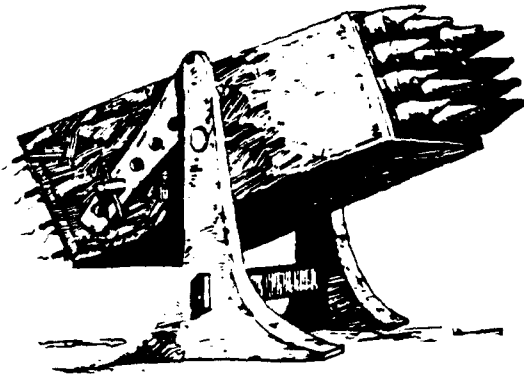

Chinese armies in the thirteenth and fourteenth centuries employed a variety of rocket-type devices against the Mongolians. Carrying such descriptions as "long snake crush enemy" and "leopard herd rush transversally," these "fire-arrows" were fired over ranges of hundreds of feet. But their accuracy was not great, and consequently they were not very effective.

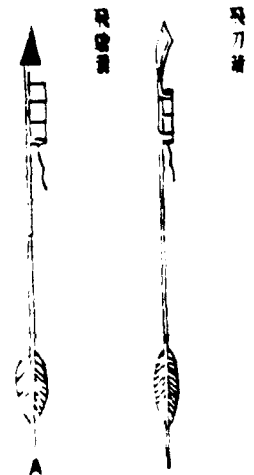
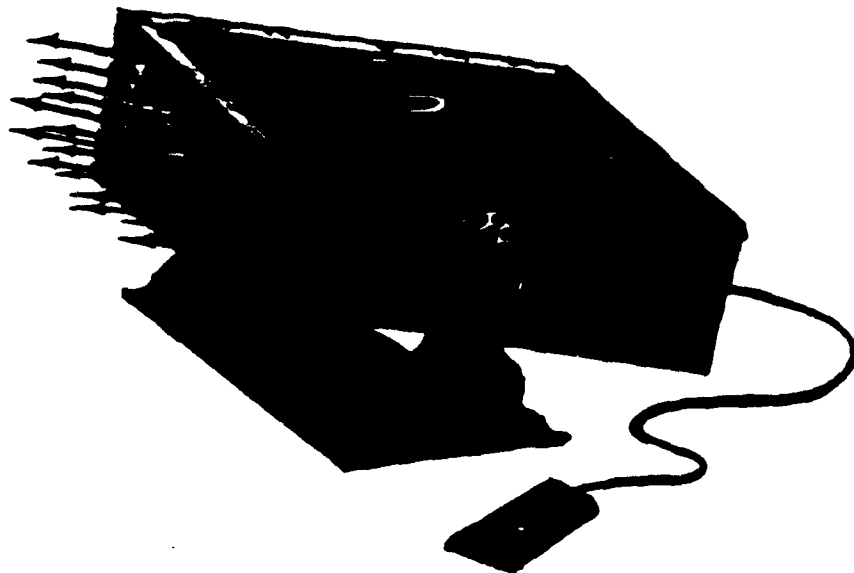

Rocketry History

Still, no direct mention is made during this period of powder being used to propel the arrows. But the Huo Yao Pien Chien type of fire-arrow may have been propelled by the force of the exploding black powder, for it is stated that five ounces of powder were placed at its end.

There is little doubt that powder-propelled fire arrows were in fairly widespread use by the beginning of the thirteenth century. The Sung Dynasty, under continuous pressure from the north, had to rely more and more on technological developments to maintain its power and protect its civilization. Its ordnance experts introduced and improved incendiary projectiles of many types, explosive grenades, and possibly cannon. They also seem to have made good use of rocket fire arrows at the battle of K'ai-fung-fu in A.D. 1232.

Rockets of one sort or another are mentioned regularly in accounts of battles following the siege of K'ai-fung-fu. During the second invasion of Japan in 1281, rockets were launched in greater quantities with devastating effects. Once they learned about the properties of gunpowder, the Japanese began to develop fireworks. Historians describe a variety of rocket-propelled arrows, their firing tubes, and several devices from which many arrows could be launched. These include "rocket-basket-arrows", which were fired from a cylinder of bamboo splints four feet long. Each cylinder contained from seventeen to twenty arrows on whose tips poison was smeared. Another contraption contained arrows "which will rush out on a solid front like 100 tigers"; they were fired from a frame, all 100 at a time, at targets up to 300 paces distance. There also was the "leopard-herd-rush-transversally" launcher, which could release forty arrows upon command, and the "long-snake-crush-enemy arrow", thirty of which were stored in a wooden box. These arrows were made of bamboo and were about three feet long. Each box of thirty weighed between five and six pounds, making this a highly mobile weapon.

Enemy armies, greatly impressed by the black powder and rockets of the Chinese, adopted them for their own use. Knowledge of these weapons was transmitted quickly to Europe, probably reaching the West by way of the Mongols and the Arabs.

According to the Arab writer Raschin-eddin, the Mongols employed fire-arrows while capturing the city of Baghdad on 15 February 1258. The exact date the Arabs adopted the rocket is unknown. Instructions for preparing black powder, the necessary propellant, are contained in a number of Arab works that date from the last half of the thirteenth century.

Writing in 1268 about events that had occurred twenty years previously, De Joinville reports in his *Histoire de Ray Saint Louis* (History of King Saint Louis) that the French first encountered rockets while maneuvering along one of the eastern branches of the Nile in an attempt to take Damietta. The Arabs, who were on the other side of the river, launched "a projectile . . . which, when it had fallen on the bank (of the river), came straight towards them, burning wildly; it is doubtless the egg that moves and burns." This interesting device was apparently a fairly flat object, filled with black powder and fitted with a tail to stabilize its path. Flames poured from little openings whose fuses were called "Ikrikh." It was propelled by three rockets, "combined such that two of these rockets served as a guiding stick for the third."

Rocketry History

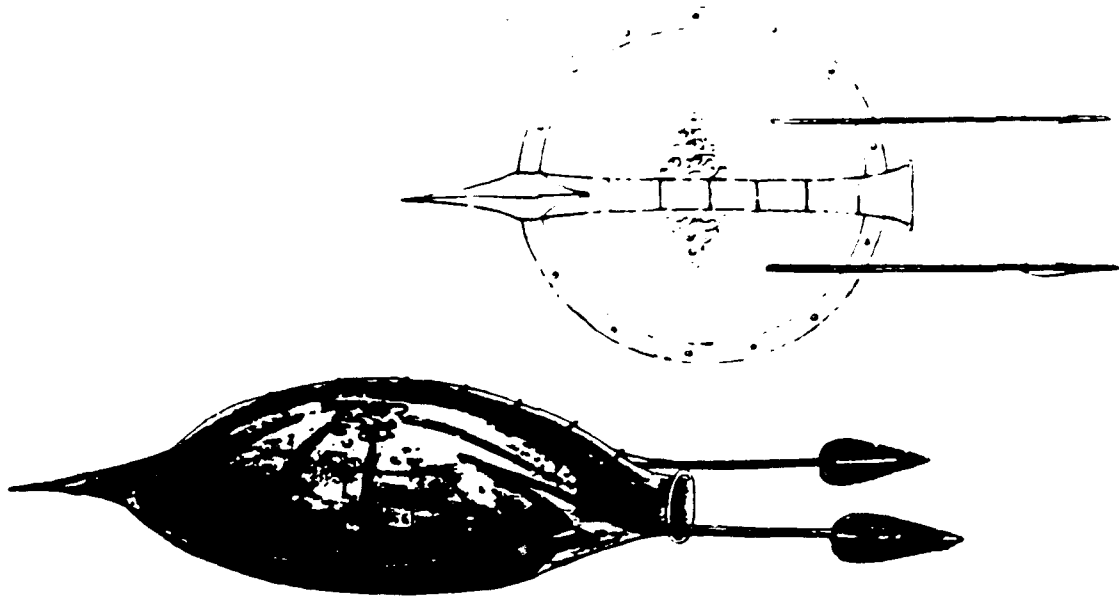

Roger Bacon (c. 1214 – 1223 to c. 1292) described the preparation of black powder before the middle of the thirteenth century, probably sometime in the late 1240s. He did not speculate on its use as a propellant for rockets, but he did describe what could have been rockets. The Epistola Fratris Rog. Baconis. de secretis operibus artis et naturae et nullitate magiae (Epistle of Roger Bacon on the Secret Works of Art and Nature and Also on the Nullity of Magic) contains numerous references to saltpeter. Wrote Bacon:

“We can, with saltpeter and other substances, compose artificially a fire that can be launched over long distances. The light of lightning and the sound of thunder can also be perfectly imitated. By only using a very small quantity of this material much light can be created accompanied by a horrible fracas. It is possible with it to destroy a town or an army . . .”

Bacon’s German counterpart, Albertus Magnus (1193 – 1280) also wrote about black powder and how to make it. In his De mirabilibus mundi (On the Wonders of the World), he gave this recipe: “Flying fire: Take one pound of sulfur, two pounds of coals of willow, six pounds of saltpeter; which three may be ground very finely in marble stone; – afterwards, a little later, at will, some may be placed in a skin of paper for flying or for making thunder.”

By the sixteenth century many Europeans were writing about, describing, and making proposals for all sorts of rockets, military and nonmilitary. While rockets remained primarily military weapons, they also were used frequently for fireworks displays, and several books paid special attention to construction of this sort of rocket. The De la pirotechnia (On Pyrotechnics) of Vannoccio Biringuccio, published in Venice in 1540, while primarily a book on metallurgy, contains a chapter on “Making Fireworks to be used in Warfare and for Festivals.”

Nathaneal Nye’s *The Art of Gunnery*, published in London in 1647, contains a 43–page section on rockets with the title *A Treatise of Artificial Fire–works for Warre and Recreation; Containing a Description to Make Sundry Kinds of Fire–works, both for Use and Pleasure, with lesse Labour and Cost than any Hath Heretofore been Published*. It includes instructions on how to make various pyrotechnic devices, has numerous illustrations of contemporary rockets, and tells the reader how to

Rocketry History

handle them. In order to fire a rocket "set your rockets mouth upon the edge of any piece of timber, battlement of a wall, top of the Gunners carriage, wheels, or any dry place whatsoever, where the rod or twigge may hang perpendicular from it, then lay a train of powder that may come under the mouth thereof, give fire thereunto, and you have done."

A new age was dawning. In one glorious century Galileo provided astronomical science with its most valuable tool to date, the telescope, and Isaac Newton filled the theoretical void and wrote laws which form the basis of rocket flight on the Earth and in space, provide quantifiable values for measuring performance, and establish a practical set of probabilities with which to design more complex methods of propulsion.

Newton was born in the rural hamlet of Woolsthorpe, not far from the town of Grantham, in Lincolnshire, on Christmas Day 1642. His mother, widowed two months before, married a second time and left Isaac in the care of his grandmother, returning to Woolsthorpe when she was widowed for the second time in 1656. The young fourteen year old Newton was brought home to begin a four year period of work on the family farm during which he proved to be a competent dreamer and student, but a poor laborer. His penchant for mathematics and physics so impressed his uncle that he was returned to scholarly servitude, and preparation for admission to Trinity College Cambridge, which he gained a year later. At the age of twenty-two he obtained his B.A. and was back at Woolsthorpe for almost the entire two-year duration of the Great Plague which began in 1665. Much of his time was spent in developing the binomial theorem and setting out ground rules for the development of differential calculus.

In 1669, Newton took a chair in mathematics at Trinity College and the young Professor spent the next few years following in the footsteps of his predecessor by concentrating on problems related to optics. Later, when approaching his forty-second birthday, Newton began setting out his theories on the qualities of gravitation, mass, and force which would be published in 1687 as the *Mathematical Principles of Natural Philosophy*.

Newton's three laws of motion defined working models for rocketry and laid the theoretical foundation for space flight upon which countless theoreticians and prophets would base their predictions thereafter. The first law stated that every object, particle or constituent of a particle will remain in a state of rest or motion until some other force is made to change it. This says that a body moving through a vacuum will continue in the same direction and at the same speed until some other force is encountered to modify its velocity (direction and speed), a highly relevant characteristic of the physical universe directly applicable to rocketry and space travel.

In the second law, Newton stated that a force acting on a physical body or particle will cause it to accelerate in the same direction as the force and that the value of the acceleration will be proportional to the force and inversely proportional to the mass of the body. In other words, force equals mass times the acceleration (or $F = ma$). This quantifies the amount of work (force, F) which a rocket must perform in order to move its weight (or mass, m) at given acceleration (a). These first two laws had been applied by earlier scientists as a direct result of observation and practice, but the third law provided a frame work against which to measure the orbits of planets, the path of the Moon about the Earth and the force exerted on a rocket when its combustible products are discharged from one end.

The third law states quite simply that every particle of matter on Earth and throughout the Universe exerts a similar force in return to that which is received and that mutual interaction generates all known forces. In short, to every action there is an equal and opposite reaction. Quite basically, it affirms that a discharge from one end of a rocket will, if of sufficient force, cause the assembly to move along in an opposite direction until, by incorporation of the first law, another force becomes dominant and changes the state within which the rocket exists.

Rocketry History

Another Newtonian law, that of universal gravitation, is related to the problem of determining the magnitude of body attraction as a mass moves through space. It states that every particle attracts every other particle with a force that is directly proportional to the product of the masses of the two particles and inversely proportional to the square of the distance between their centers. This inverse square property means that if a rocket travels out from Earth to a point four times the distance from the Sun as the Earth, it will feel a pull from the Sun only one-sixteenth as strong as the pull felt by the Earth.

The implications of these laws were fully appreciated by Newton's contemporaries, but their physical application to rockets and the like was still far off. Despite his other accomplishments, the *Mathematical Principles of Natural Philosophy* established Newton as a giant among his peers and today he is universally recognized as one of the greatest scientists that ever lived. After a term as member of Parliament, Newton went on to become Master of the Mint. Following a short illness, he died at the age of eighty-four on 20 March 1727.

At last a precise dialogue had been established between practical experiments and natural law, providing an opportunity to exploit technology and apply quantifiable values to design.

The eighteenth century was almost over, however, before Europeans became seriously interested in the military potential of the rocket – and then only because they suddenly found themselves on the *receiving* end of this weapon. The first major engagements with rockets that involved Europeans took place in India, where troops under Tippoo Sultaun of Mysore, fired them against the British during the two battles of Seringapatam in 1792 and 1799.

Soon after their Indian experience, the British began developing rockets themselves. At the Royal Laboratory of Woolwich Arsenal, Colonel (later Sir) William Congreve initiated a series of experiments with incendiary barrage rockets.

"In the year 1804," wrote Congreve in *A Concise Account on the Origin and Progress of the Rocket System*, "it first occurred to me, that, as the projectile force of the rocket is exerted without any reaction upon the point from which it is discharged, it might be successfully applied, both afloat and ashore, as a military engine. . . . I knew that rockets were used for military purposes in India; but that their magnitude was inconsiderable, and their range not exceeding 1000 yards." He then designed and built a 2,000 yard rocket.

Congreve described his 32-pound rocket in clear, semi-technical terms. Its "carcass is the largest of the kind that has hitherto been constructed for; it is completely cased in a stout iron cylinder, terminating in a conical head; it is 3 feet 6 inches in length, 4 inches in diameter, and weighs, when complete, 32 pounds. . . . The stick is 15 feet long, and 1 1/2 inches in diameter, and is so constructed, that it may be firmly attached to the body of the rocket, by a simple and quick operation, at any required time."

The rocket contained "about seven pounds of carcass composition," and cost one pound sterling. Congreve spoke of 13,109 rockets having been manufactured up to August 1806, and mentioned briefly of having experimented with 42-pounders with ranges of 4,000 to 5,000 yards.

Congreve's proposal to attack Boulogne, France was accepted by the British military. To insure maximum accuracy, Congreve attached to each rocket a 15-foot guiding stick. The attack was postponed until the fall when, on 8 October, eighteen boats with rockets aboard rowed into the bay. "In about half an hour above 2,000 rockets were discharged. The dismay and astonishment of the enemy were complete – not a shot was returned – and in less than ten minutes after the first discharge, the town was discovered to be on fire."

Rocketry History



Rocketry History

Congreve's rockets were employed frequently in the War of 1812 between Britain and the United States. Their best publicized moment came during a bombardment of Baltimore's Fort McHenry on the night of 13-14 September 1814, when a young lawyer named Francis Scott Key immortalized the spectacle of "the rocket's red glare" in a verse that later became the national anthem of the United States. Although dramatic, rockets were not particularly effective in this engagement. The bombardment was continued, more or less steadily, for twenty-five hours, but only four Americans were killed and twenty-four wounded.

The rockets that Key witnessed weighed about thirty pounds and carried incendiary charges. They were fired from the *Erebus*, a 20-gun sloop that had been converted under Congreve's direction into a rocket-firing bombardment vessel. The *Erebus* has some twenty long, boxed frames extending from square openings, known as "scuttles", cut in the side of the ship. The boxes protected the interior of the ship from sparks and flames. Within them were large metal rocket-firing tubes. The tubes were fired by pulling lanyards.

Two basic Congreve designs were employed during the War of 1812: (1) case-shot rockets used as a substitute for, or as an auxiliary to, artillery; and (2) rockets loaded with inflammable materials whose purpose was to start fires.

The first, or case-shot, type contained carbine balls, which flew out like shrapnel when a charge of powder exploded. The rockets, when used with infantry, weighed from three to twelve pounds and were fired from a prone position. The rockets also could be fired from adjustable tripod stands, mounted on the decks of ships or in their rigging. Often they were fired from small boats, including those propelled solely by oars. They had a range of up to 3,000 yards.

In another engagement on 8 June 1814, the British fired rockets against American ships on the Patuxent River at the mouth of St. Leonard's Creek. The accuracy of the rockets was poor and they did little damage, but their range was greater than that of cannon and the Americans were unnerved by the attack. On 10 June, the British did succeed in sinking two barges with rockets.

As the nineteenth century advanced, rocket designers concentrated on improving the weapon's accuracy. The normal way to control the flight direction of the early rockets was by stick. Congreve's incendiary 3.5-inch rockets, for example, were guided by a fifteen-foot stick attached to the case by hoops. William Hale, an English inventor, gained fame for his development of spin-stabilized rockets, which were subsequently used in Europe and Asia, and by the United States during the Mexican War in 1846-1848. Imparting spin to rockets was the first step since the introduction of the stick in improving their accuracy.

Efforts also were made to increase range, but Congreve's standard rockets, which flew about 3,000 yards, remained pretty much in a class by themselves.

The American Army made limited use of rockets during the Mexican War. During the period between the Mexican War and World War II, Hale and Congreve rockets declined in importance, partly because of storage problems. When the Mexican War rockets were taken out of storage during the Civil War, it was found that their black powder charges had not maintained their bond with the cases. Rockets were used during the Civil War, but only sporadically and indecisively. The payloads of the Union rockets usually contained highly inflammable compounds, but occasionally musket balls were placed in a hollow head and exploded by time fuses.

Generally speaking, however, interest in rockets declined once the spur of war was removed. By the end of the nineteenth century, rocket research was being carried on by only a few experimenters.

Rocketry History

Pedro A. Paulet, a Peruvian chemical engineer, is reported to have conducted experiments in Paris from 1895 to 1897 with a small, 200-pound-thrust liquid rocket motor made of vanadium steel. He was forced to discontinue his work because of economic difficulties and his neighbors' complaints.

Paulet's rocket's propellants were nitrogen peroxide and gasoline; ignition was by a spark gap in the combustion chamber, and tests were satisfactory. The motor "weighed a little over 5 pounds, producing its 200 pounds of thrust at 300 explosions per minute." Paulet claimed it could be operated for an hour without "suffering appreciable deformation."

At the turn of the century, rockets were being fired into clouds and exploded, hopefully to prevent hailstorms. Alfred Maul attempted to loft cameras to high altitudes with rockets and then take pictures of the Earth below, but his work was discontinued as the airplane arrived on the scene.

The ebb in interest in rockets that had begun in the nineteenth century continued into the first quarter of the twentieth, although the reasons for the decline changed. Lack of war as an incentive to weapons development was no longer a factor. Instead, it just seemed that the rocket had become obsolete. With the advent of radio, rockets lost importance as a method of signaling. Militarily, the rocket could no longer compete with artillery, where rifled barrels, breech loading, and other new techniques led to great increases in range and accuracy.

In the First World War, nevertheless, the Allies did make minor use of rockets, primarily for signaling and illuminating enemy positions. Both on land and at sea World War I rockets found service in laying smoke screens. As weapons of destruction they saw limited use, mostly in France.

The French developed Le Prieur rockets (named after Naval Lieutenant Y.P.G. Le Prieur, who suggested them) that were fired either from Nieuport (or other) airplanes or from the ground against German Zeppelins and balloons. Normally, a biplane would carry eight rockets, four mounted on each side of the fuselage.

CHANIS TRANSCRIPT. AUGUST 9. 1865.

BENJAMIN LINDSEY.
U. S. COMMISSIONER OF PATENT OFFICE, BRANDEIS BUILDING, NEW YORK.

RIGHT & CO.
COMMISSION MERCHANTS,
RIO DE JANEIRO, BRAZIL.

G. BREWER & CO.
SOLE AGENTS,
GENERAL SHIPPING AND COMMISSION MERCHANTS.

BURTON & TRUMBULL
S. W. BURTON, J. H. TRUMBULL.

COMMISSION HOUSE
AT BRANDEIS BUILDING, N. Y.

PATENT ROCKET HARPOONS AND GUNS.



FASTER TO AND KILL INSTANTLY WHALES OF EVERY SPECIES WITH PROPER LINES AND BOATS.

G. A. LALLEBAUM, NEW YORK.

J. & W. R. WING & CO.
10 SOUTH WATER STREET—NEW BEDFORD.

PELEG & FREDERICK SLOCUM.
NO. 1 SOUTH WATER STREET, NEW BEDFORD, MASS.

SEAMAN'S INFITING & OUTFITTING GOODS.

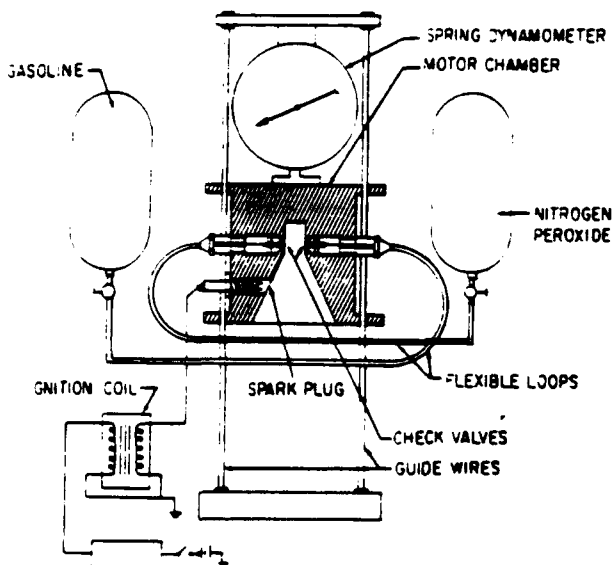

Rocketry History

In the United States, some work was done on short-range combat rockets. Dr. Robert H. Goddard, the father of modern rocketry, developed some rockets that were test fired just a few days before the war ended. His work was to bear fruit later, but in the frenzied atmosphere of World War I, it was generally overlooked.

During the Spanish Civil War, 1936-1939, the rocket staged a brief, and somewhat unusual, appearance. Converted sea-rescue rockets were placed into service for transporting propaganda materials behind enemy lines. The nosecone was specially constructed so that it would burst open at a predetermined time and release its payload of propaganda leaflets, which were printed on very thin paper.

Although the Spanish Civil War was regarded as a testing ground for a coming world war, the peripheral role given to rockets provided a poor indication of the important role they were to play in the next few years. While practical use of rockets languished after World War I, a few men, working in obscurity and with limited funds, had laid the foundation for a theoretical and technical revolution.

CHAPTER II PROPULSION DEVICES

Although a rocket is a reaction device, not all reaction devices are rockets. A rocket is a special case because it contains all the elements it needs to operate, including both fuel and oxygen. A jet airplane engine, by contrast, is a reaction device that uses the oxygen in the air to support combustion of the fuel carried on board.

The word "propulsion" comes from the Latin word "propellere" which means "to drive away". Clearly this definition implies the existence of a body, a force (drive or push), and a preferred direction (forward or onward). As we shall see, according to Newton's third law of motion, forces occur only in equal and opposite pairs, and the existence of a force on a body therefore entails a reaction. This reaction cannot be on the body itself, since a pair of equal and opposite forces on the same body will not "drive or push forward or onward." Therefore, one or more additional bodies are essential to propulsion. For a self-propelled vehicle like an automobile, the second body is the earth itself, and the act of propulsion entails a transfer of momentum between the automobile and the earth. In cases of particular interest in this text, the second body is usually a fluid medium. In the instance of a propeller-driven airplane, this fluid is the surrounding air, while in the case of a rocket it is a fluid carried along with, and discharged from, the rocket itself.

In a jet airplane, the major part of the fluid used in propulsion is the surrounding atmosphere, but the fuel, which may constitute 2% of the propulsive fluid, is carried along and discharged as in a rocket.

If we consider an airplane in straight level flight at uniform speed, it is clear that the horizontal component of the resultant force acting on the airplane must be zero. (There is neither acceleration or deceleration.) We know that to propel the airplane it is necessary to overcome the drag (frictional and induced) of the fluid on the body. If this is done by means of a propeller, the force of the propeller on the airplane must be sufficient to cancel the drag forces. The propeller can produce this force only by transferring momentum to the stream of air which passes through it. The drag forces also transfer the momentum to the surrounding air, and indeed, the horizontal momentum change due to the propeller thrust and the horizontal momentum change due to drag forces must be equal and opposite. Many erroneous ideas of propulsion by jets were prevalent as late as the 1920s. It was well known at this time that a fireboat directing its stream of water at a fire would gradually move away from the fire. Eminent professors of engineering were heard to scoff at this observation, saying that "you can't push on a rope." It apparently was difficult for people to conceive of something propelling itself without some medium or body to push on. The idea of the device pushing on a medium which was being discarded was understood by only a few. Now it is a part of the knowledge of most, if not all, newly graduated mechanical and aeronautical engineers.

Development of Propulsive Devices

The history of propulsion illustrates the interaction between economic or military need and technological advances. Although da Vinci's sketches of screw propellers date from the fifteenth (or possibly early sixteenth) century, the need for such a device did not arise until the development of the steam engine provided an appropriate driving mechanism. The first successful steamboats were driven by paddle wheels, but the paddle wheel must operate at the interface of two media (air and water) and is therefore clearly unsuitable for submarines, lighter-than-air ships, and airplanes. (It might also be said to be unsuitable for any ship when the sea is rough and the interface is shifting about). The first successful submarine, the first airship, and the first airplane all had screw propel-

Propulsion Devices

lers. The airplane propeller still serves well when the speed of the aircraft is less than 350 miles per hour. When man began to want to fly at higher speeds (originally for military reasons), a lighter and smaller power plant was essential. The jet engine answered this need, while at the same time avoiding the difficulties encountered by propellers operating at supersonic tip velocities. It is interesting to note that there was no incentive for developing a jet engine until the art of airplane design had advanced enough to make high-speed flight practical. As a matter of fact, the jet is inappropriate to low-speed flight, and the propeller provided an essential first step without which we would almost certainly not have developed airplanes at all.

The jet engine is a good example of the solution of a technical problem – that of high-speed flight – which required that many conditions exist simultaneously. First, the need had to exist. Then, there had to be sufficient mastery of the art of airplane design, including aerodynamics, structure, and control. Finally, there had to be the knowledge of turbomachinery design and the availability of materials capable of withstanding high temperatures. These are only some of the major hurdles. Of course the solution of the problem also depended on a sophisticated manufacturing technique – forging, casting, cold-forming, welding, and machining – and on the availability of countless “minor” but essential items: bearings, seals, lubricants, pumps, control devices, etc. In any development as complex as the jet engine, special circumstances are bound to arise which require changes and advancement of the technology in these “minor” items. However, without a reasonable state of development in these, as well as the major items, the development period would be likely to stretch out until it became clear that the project had better be postponed until the necessary supporting technology was able to catch up. John Barber patented a gas turbine in 1791. There is little doubt that Barber had insufficient knowledge of basic mechanics, and certainly insufficient knowledge of fluid mechanics to develop a successful gas turbine, but even if he had had all the fundamental knowledge we have today, his job would still have been impossible until the general technological level had risen enormously. Materials and manufacturing techniques were not adequate even to begin this task until well over a hundred years later. Furthermore, had he been able to build a gas turbine, there would have been no economically feasible use for it.

History is full of such examples of inventions made too soon. They emphasize the importance of the engineering task of determining when a need exists and when supporting technology, both in theory and practice, are sufficiently advanced to begin a new development. To determine these facts involves a knowledge or at least an estimate of what extensions of theory and what refinements of practice are essential to its success.

The first successful aircraft propulsion device was Henry Gifford's steam engine powered, propeller-driven dirigible balloon, which went from Paris to Trappes in 1851 at an average speed of about seven miles per hour. However, for an airplane power plant, the necessary water supply (or condenser) and boiler would be so unreasonably heavy that even if the steam engine weighed nothing, only very poor airplane performance would be possible.

The successful airplane, in a practical sense, had to wait for the development of the internal combustion engine, which eliminated the necessity for either a water supply (or condenser) or a boiler. At the time of the Wright brothers' experiments, available internal combustion engines were still too heavy, but they did exist, and the time was ripe for their development to a reasonable engine weight per horsepower. The Wright brothers had to take on this problem, along with the design and construction of the first powered airplanes to demonstrate controlled flight.

The possibility of propulsion by means of a jet had been well known for many years before it was usefully applied by von Ohain (first flight August 27, 1939) and Whittle (first flight May 15, 1941). Before jet propulsion could become feasible, it was essential that airplanes be designed and

Propulsion Devices

built for high speed. It was also necessary that the art of design and construction of high-temperature turbines and efficient compressors be advanced considerably to meet the stringent requirements (primarily light weight combined with high efficiency) of a useful aircraft engine. The development of the sophisticated rocket is an illustration of a similar series of events, as we have already seen in the previous chapter.

What are the basic differences (and similarities) among the various propulsion devices?

Jet propulsion is a means of locomotion whereby a reaction is imparted to a device by momentum of ejected matter. According to Newton's 1st law, when the ejected mass is accelerated (given a momentum change), a force is required to produce this acceleration, and by Newton's 3rd law there is

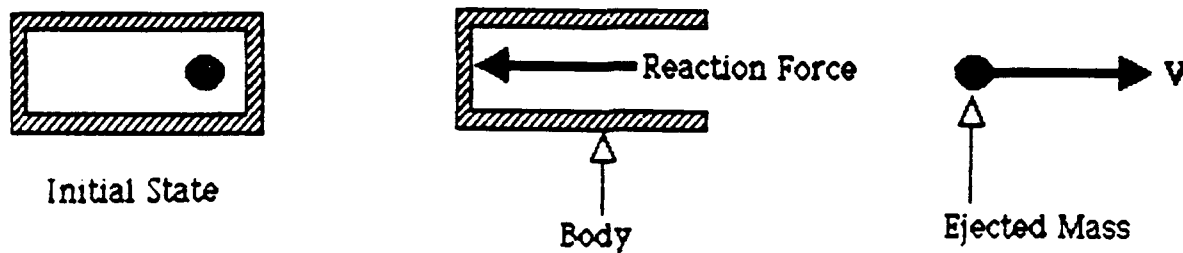

an equal and opposite reaction force which is termed thrust.

Two types of jet propulsion can be distinguished: rocket propulsion, where the matter to be ejected is stored internally within the moving device, and duct propulsion, where the surrounding fluid is ducted through the device and accelerated to a greater velocity by mechanical or thermal means prior to ejection. There are also combination schemes that eject both stored matter and some of the surrounding medium.

2.1 Duct Jet Propulsion Devices

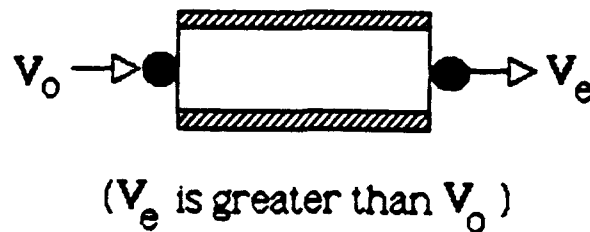

Part of the surrounding fluid, the working fluid is ducted through the device and accelerated to a greater velocity by mechanical or thermal means.

Propulsion Devices

2.2 Rocket Propulsion Devices

Matter to be ejected is stored within the device. (A rocket has to supply its own working fluid).

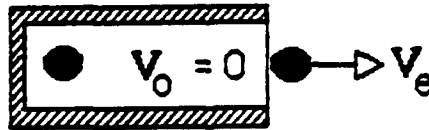

The end result in each case is the production of THRUST.

The idea of jet propulsion is old, and only in the last few decades has it been found to be useful and practical. Many different types of jet propulsion systems have been successfully designed for a large variety of applications.

2.2.1. Ducted Jet Propulsion Engines

Ducted engines are mentioned here primarily to provide a more complete spectrum of propulsive engines.

MECHANICAL COMPRESSION UNITS. The working fluid is compressed by mechanical means, burned, and expanded in a nozzle. This compression is usually accomplished by a mechanical compressor, which is driven by a turbine (turbojets) or by other means. The momentum of the ducted fluid is increased and, thus, produces a propulsive force.

PURE DUCTS. These units are similar in principle to the mechanical compression units, except that no compressors or turbines are used. Compression of flowing fluids is achieved by proper shaping of the duct. Ramjets are ducts where the medium is air.

Five types of air breathing jet propulsion engines are illustrated on the next page.

Propulsion Devices

RAMJET

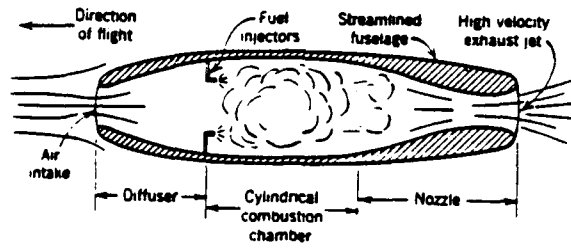

Turbojet

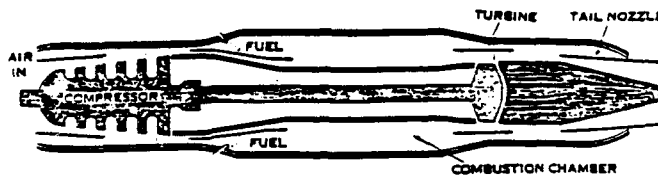

Turbofan

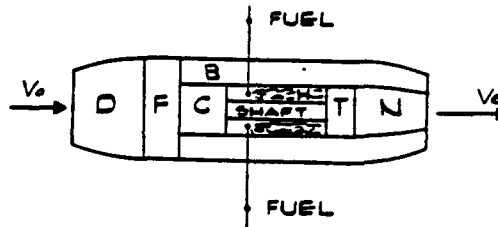

Turboprop

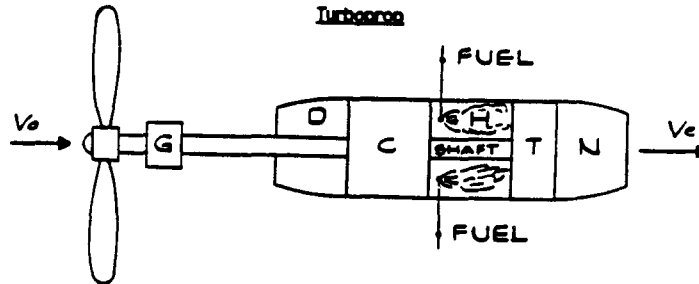

Pulse-Jet

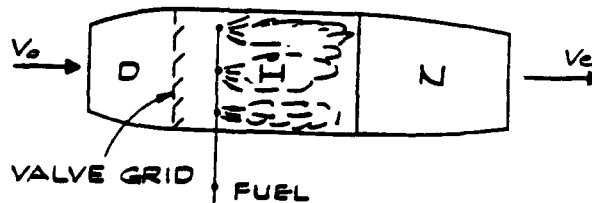

D = DIFFUSER
N = NOZZLE

Propulsion Devices

2.2.2 Rocket Engines

A rocket engine powered vehicle carries all of its own propellant. The rocket engine is therefore capable of operating independent of its environmental medium and, thus, can be used in the air, under water, or in the vacuum of space. Rocket engines can be classified according to the type of energy source used (chemical, nuclear, or solar), the application (aircraft engine, missile engine, assisted take-off engine, space vehicle engine, etc.), size, type of propellant, type of construction, or number of engines used in a given vehicle.

CHEMICAL ROCKET ENGINES. The energy from a high-pressure combustion reaction of propellant chemicals, usually a fuel and an oxidizing chemical, permits the heating of reaction product gases to very high temperatures (4500 to 7500°F). These gases subsequently are expanded in a nozzle and accelerated to high velocities (6000 to 14000 ft per sec). According to the physical state of the propellant, there are several different types of these rocket engines.

LIQUID PROPELLANT ROCKETS use liquid propellants which are fed under pressure from tanks into a combustion chamber. The liquid propellants usually consist of a liquid oxidizer (for example, liquid oxygen) and a liquid fuel (for example, gasoline).

In the combustion chamber, the propellants react to form hot gases, which, are accelerated and ejected at a high velocity through a supersonic nozzle, thereby imparting momentum to the system. A liquid rocket usually permits repetitive operation and can be started and shut off at will. If the thrust chamber is provided with adequate cooling capacity, it is possible to run liquid rockets for periods exceeding one hour, dependent only on the propellant supply. A liquid rocket propulsion system is, however, relatively complicated in design; it requires several precision valves and a complex feed mechanism which often includes propellant pumps, turbines, or a propellant pressurizing device, and a relatively intricate combustion chamber.

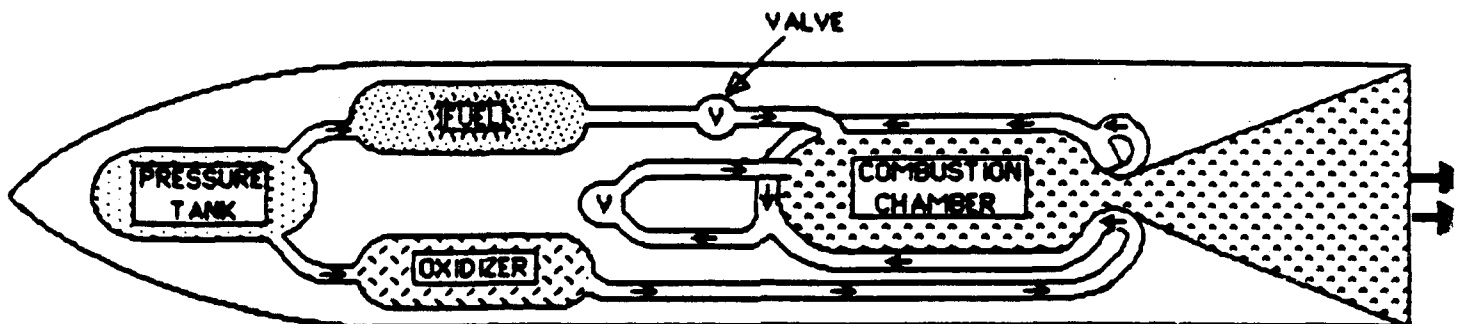

In **SOLID PROPELLANT ROCKETS** the propellant to be burned is contained within the combustion chamber or case. The propellant charge is called the "grain" and it contains all the chemical ingredients for complete burning. Once ignited, it usually burns smoothly at a nearly constant rate on the exposed surface of the charge. Because there are no feed systems or valves such as there are in liquid units, solid propellant rockets are relatively simple in construction.

Propulsion Devices

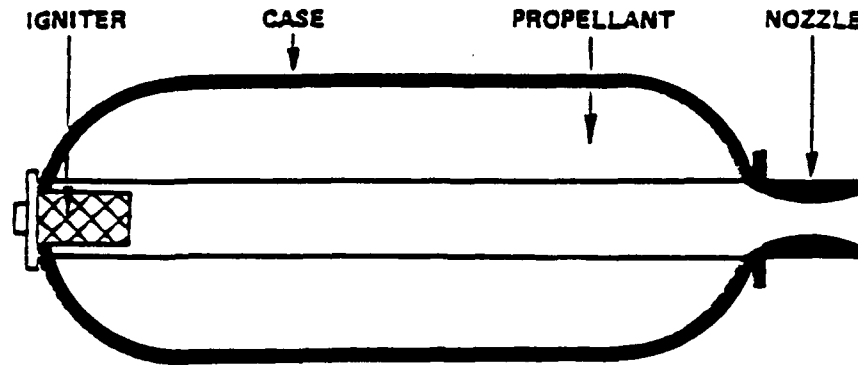

HYBRID PROPELLANT ROCKET ENGINES use both a liquid and a solid propellant. For example, if a liquid oxidizing agent is injected into a combustion chamber filled with a solid carbonaceous fuel grain, the chemical reaction will produce hot combustion gases.

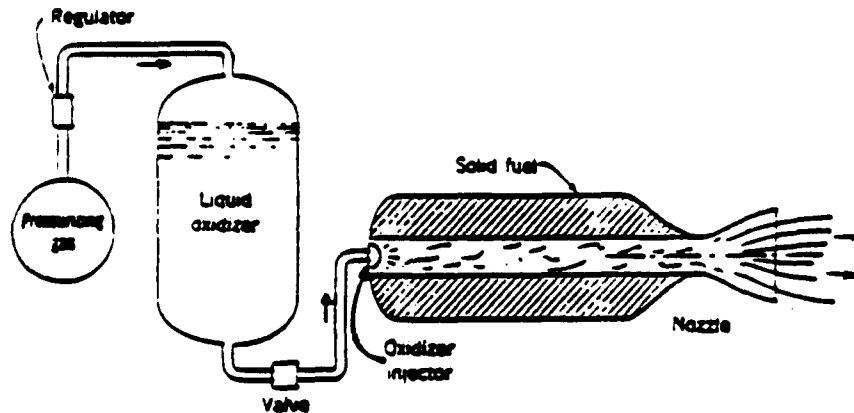

Combinations of Ducted Jet Engines and Rocket Engines

Of the many different ways of combining the principles of rocket engines and ducted propulsion units, only a few of the more interesting versions are mentioned here briefly. These are experimental or developmental concepts which are mentioned only in passing.

A **DUCTED ROCKET** is essentially a modified ramjet in which one or more small rockets are used to ignite the fuel, to stabilize the flame, or to augment the ramjet by an injector-like action. The mixing action of the high-velocity rocket gases with the relatively slow gases of the duct permits an increase in thrust particularly at low flight velocities.

Propulsion Devices

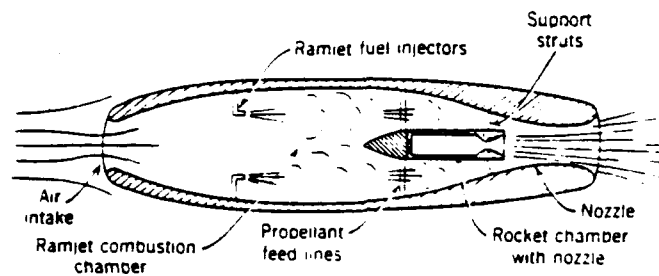

In the **CONDENSED-AIR ROCKET**, gaseous air is collected in flight and condensed to liquid air, which is subsequently used in a rocket combustion reaction. The stored fuel (liquid hydrogen) absorbs heat in its vaporization and, thus, cools and condenses the incoming air. If it is possible to separate the air into enriched air and excess nitrogen, which is rejected and thrown overboard, then the rocket combustion reaction will be more energetic and give more performance than if only the liquid air were burned with the hydrogen.

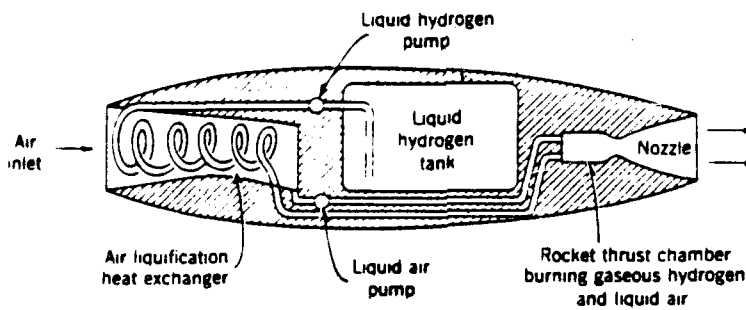

Nuclear Rocket Engines

Three different types of nuclear energy sources can be considered for delivering heat to a working fluid, usually liquid hydrogen, which is subsequently expanded in a nozzle and, thus, accelerated to high ejection velocities (20000 to 35000 ft per sec). They are the **FISSION REACTOR**, the **RADIOACTIVE ISOTOPE DECAY** source, and a **FUSION REACTION** source. All three types are basically extensions of liquid propellant rocket engines, except that the heating of the gas is not accomplished by chemical reaction, but rather by energy which derives from transformations within the nucleus of atoms.

Propulsion Devices

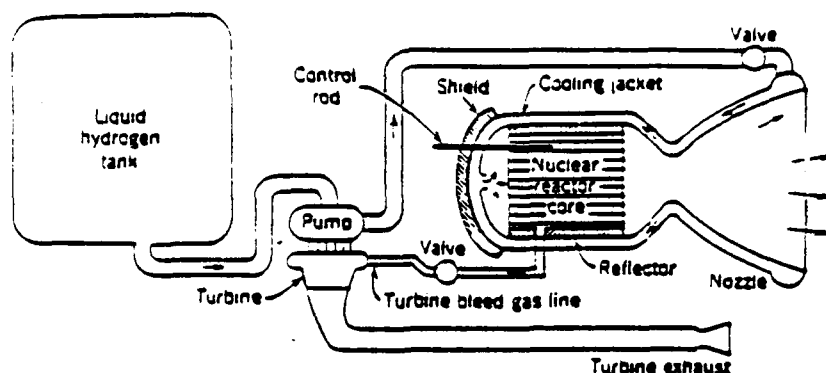

In the nuclear fission reactor rocket heat can be generated by the fission of uranium. This heat is subsequently transferred to the working fluid. The high temperatures of the reactor (above 4000°F) and the radiation effects on materials and on humans present special problems. In the isotope decay engine a radioactive material gives off radiation, which is readily converted into heat and, thus, used to raise the temperature of a working fluid. The use of fusion, which is the third method of using nuclear energy in propulsion, could become attractive but the control of a continuous fusion process is at this time not sufficiently understood to be practically used.

Electrical Rocket Engines

In the ARC HEATING ROCKET engine, electrical energy is transformed into heat in an arc which is struck between two electrodes and, thus, the temperature of the working fluid is raised as it passes through the arc. The heated gas then expands thermodynamically through a nozzle and, thus, is accelerated and ejected at high velocities (25000 to 65000 ft per sec).

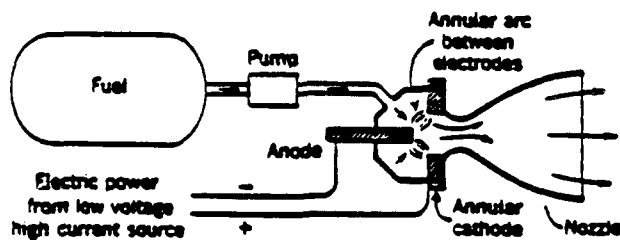

Propulsion Devices

Rocket vs. Air-Breathing Engines











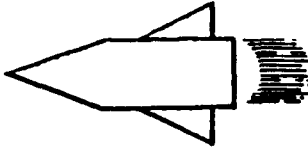

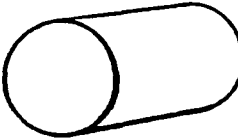
Rocket propulsion engines have the following advantages over air-breathing engines:

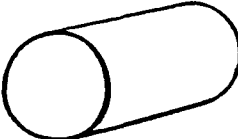
- (1) Thrust is essentially independent of speed and altitude.
- (2) Thrust/ A_{frontal} is largest of all known propulsion systems.
- (3) Thrust/ W_{engine} is largest of all known propulsion systems.
- (4) No altitude ceiling (or depth floor).

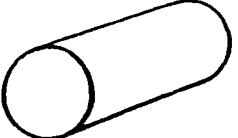
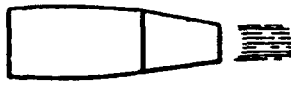
A summary of propulsion device advantages and comparisons appears in the following table.

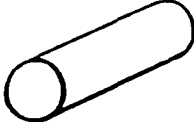
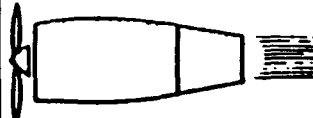
Propulsion Devices

Operational Characteristics of Various Jet-Propulsion Units

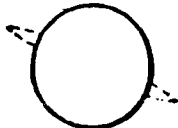
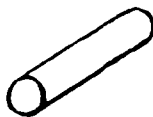
PROPULSION METHOD	DIAGRAM OF UNIT	RELATIVE FRONTAL AREA (DRAG)	RELATIVE WEIGHT OF FUEL FOR GIVEN DURATION	PROBABLE RANGE OF FLIGHT SPEEDS
ROCKET				SUPERSONIC
RAMJET				SUPERSONIC
PULSEJET				SUBSONIC
TURBOJET				SUBSONIC AND SUPERSONIC
TURBOPROP				SUBSONIC
SUPERCHARGED RECIPROCATING ENGINE				SUBSONIC

CHAPTER III PROPERTIES OF MATTER

The term "propulsion" as we have seen means to push or force away. But push what? Force what?

Our entire surroundings are made of "matter": The books you read, the air you breathe, the orange juice you had for breakfast this morning – all matter. The word *matter* comes from the Latin word *materia* which means material, constituents, physical substance. When we speak about properties of matter, we are not interested in the size of the book, or the color of the orange juice. We are interested in primary properties like temperature, pressure, density, mass and so on. This chapter is devoted to these characteristics.

But what is matter? This word itself seems to be broad in scope yet short in definition. Throughout the history of the world, the question of the ultimate nature of matter has received much attention from philosophers and scientists. Anaxagoras (500–428 B.C.) claimed that matter is made up of minute particles which he called seeds. But Anaxagoras was a radical in this and other respects, and he was soon exiled for his views. Most of the Greek philosophers believed that there are four essential elements – fire, air, water, and earth – from which all things are made. Aristotle (384 – 322 B.C.) added a fifth element – a celestial element – which he called ether. Aristotle and the majority of his contemporaries believed also that matter is continuous – that it could be subdivided into smaller and smaller bits without limit.

In the Middle Ages, the atomists and alchemists were inclined to break away from the tradition of Aristotelian infallibility, and assume that matter is composed of particles, called atoms, which cannot be further subdivided. By rearranging and changing the proportions of the atoms of the elements – fire, air, water, and earth – any substance, they thought, could be changed into any other substance; hence the many dark and mysterious schemes for transmuting the base metals into gold.

The alchemists never quite succeeded in their efforts, and their assumption that all matter is made of fire, air, water, and earth, gradually became discredited. Their experiments, and the work of the chemists who followed them, showed the way to a more useful theory, one that was clearly stated by the English chemist, John Dalton (1766 – 1844), and is still accepted today. Matter, we now believe, is made up of atoms of the elements. All the atoms of a given chemical element – aluminum, for example – are alike, and are different from the atoms of any other element, such as oxygen or copper.

For nearly fifty years after Dalton's death there was little need to wonder what atoms are made of, and how they differ from one element to another. The physicists, studying the behavior of gases, found that the atoms acted like tiny indivisible grains of matter, possibly spherical in shape, and elastic like billiard balls. The chemists, who studied the compounds that are formed when atoms of the different elements get together into molecules, had to imagine that each atom has little hooks (or something of the sort) by which it can be attached to other atoms. But neither group had any particular reason to worry about the internal construction of an atom, nor any good basis for a theory about what atoms are like inside.

Therefore, it was something of a shock to the scientists of the twentieth century when evidence began to accumulate, showing that atoms are made up of various combinations of electrons and protons, and are actually filled mostly with empty space. Ordinary chemical reactions simply had not been drastic enough to produce these new effects. High-powered radiation and electrical agents were needed. Today, with the use of high-speed atomic particles, we can even smash to pieces the nuclei of the atoms, and thereby transmute one element into another. The dream of the alchemists has been realized; but the efficiency of the transmutation process is very low.

Properties of Matter

But more practical questions await our immediate attention. In the first place, how shall we classify the various forms of matter? It is customary to distinguish between solids, which have a fixed shape and volume, and fluids, which flow and freely change their form. Fluids are further subdivided into liquids, which are constant in volume, and gases, which can be readily compressed or expanded.

This classification is not always satisfactory because, with sufficient provocation, solids change their form just as do fluids. Thus, a lead bullet, which ordinarily seems pretty solid to us, smashes flat on impact with a steel plate. Even the steel plate may be dented or pierced, and hence deformed, by a bullet made of steel. And how would you classify butter, axle grease, or pitch? Soft butter may be considered either a solid or a semi-liquid. Cold pitch normally appears to be solid; but if left to itself, it will gradually flow and, after some days or weeks, will assume the shape of the vessel in which it is placed. We know that even wooden beams may sag permanently - especially if they are allowed to become damp while subject to continuous strain. For our purposes in discussing rocket propulsion, however, the customary definitions of solids, gases, and liquids will be sufficient.

The study of propulsion devices is basically a study of matter as it flows through or around various shapes and contrivances such as diffusers, nozzles, airfoils, and combustion chambers. In order to make an intelligent study of such devices, it is essential to have a clear concept of matter. Our scientific and engineering predecessors have established certain fundamental qualities or properties of matter which define its state or condition. These qualities and their definitions are a part of the language of engineering and it is mandatory that they be understood.

3.1 Pressure

There is a difference in the way a force acts on a fluid and on a solid. A force can be applied to a single point of a solid and be sustained by it; but a force can only be applied to and sustained by a surface of an enclosed fluid. Furthermore, in a fluid at rest such a force is always directed at right angles to the surface. A fluid at rest cannot sustain a tangential force; the fluid layers would simply slide over one another when subjected to such a force. It is convenient, therefore, to describe the force acting on a fluid by specifying the pressure P , which is defined as the magnitude of the normal force per unit surface area. Some common units of pressure are lb/in^2 , lb/ft^2 , and nt/meter^2 .

$$\text{Pressure} = \text{Force} / \text{Area}$$

Let's consider a steel block weighing 10 pounds sitting on a table. The block has a base of two square inches. The force (weight) of the block thus acts on this base area to produce a pressure at the interface of the block and table of

$$P = (10 \text{ pounds}) / (2 \text{ in}^2) = 5 \text{ psi}$$

This pressure is uniform over the interface.

Suppose that instead of the block of steel we had a container of water of the same weight and base area (two square inches). Again, the interface pressure is 5 psi. Now, let us go inside the container and see what pressure the water exerts on the bottom of the container (assuming a weightless container). Here again, the pressure will be the force per unit area or 5 psi. **The force the water exerts on the bottom of the container is equal to the weight of the column of water above it.** If above the column of water we had a column of another fluid, the force that would be felt at the bottom of the container would be the sum of the weights of the fluids.

Properties of Matter

Thus, the pressure or force per unit area that a fluid (liquid or gas) exerts on a surface or body immersed in it is equal to the weight of the fluid above it divided by the area concerned.

$$P = W / A$$

where W is the weight of the fluid above the area A .

If there are successive layers of the fluid as pictured below, then the pressure on the area A would be equal to the weight of the successive fluids 1, 2, and 3 divided by the area A .

$$P = (W_1 + W_2 + W_3) / A$$

If we designate the weight densities ($\#/ft^3$) of the three fluids as $(\rho g)_1$, $(\rho g)_2$ and $(\rho g)_3$ then

$$W_1/A = (\rho g)_1 h_1 \quad W_2/A = (\rho g)_2 h_2 \quad W_3/A = (\rho g)_3 h_3$$

and

$$P = (\rho g)_1 h_1 + (\rho g)_2 h_2 + (\rho g)_3 h_3$$

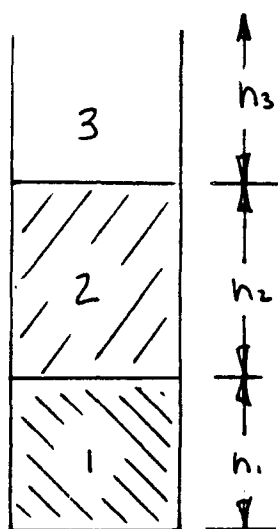

Thus, the pressure on any immersed body is equal to the product of the weight density and height of the fluid above the body. If there is more than one fluid above the body then the pressure on the body is merely the sum of these products for each successive fluid. Water, as an example, has a weight density (ρg) of $62.4 \text{ lb}/ft^3$.

This equation tells how pressure varies with elevation in a fluid. As elevation increases (depth below the surface decreases) pressure decreases. If a liquid has a free surface, this is the natural level from which to measure distances. To change our reference level to the top surface, we take y_2 to be the elevation of the surface, at which point the pressure P_2 acting on the fluid is that exerted by the earth's atmosphere P_0 . We take y_1 to be at any level and we represent pressure there as P . Then,

$$P_0 - P = -\rho g(y_2 - y_1)$$

But $y_2 - y_1$ is the depth h below the surface at which the pressure is P so that

$$P = P_0 + \rho gh$$

This shows clearly that the pressure is the same at all points at the same depth.

For gases, ρ is comparatively small and the difference in pressure at two points is usually negligible. Thus, in a vessel containing a gas the pressure can be taken as the same everywhere. However, this is not the case if $y_2 - y_1$ is very great. The pressure of the air varies greatly as we ascend to great heights in the atmosphere or descend to great depths in a mine. In fact, in such cases the density ρ varies with altitude and must be known as a function of y before we can evaluate pressure.

Properties of Matter



If we concern ourselves with two locations within the fluid, the pressure difference between the locations can be expressed as

$$P_2 - P_1 = \rho g (h_2 - h_1)$$

This equation is valid, regardless of the shape of the container.

As you can see, the pressure in a stationary fluid depends only on the depth and on nothing else. This fact is of special significance. It means, for instance, that the size of the lake stored up behind a dam has nothing to do with the force tending to burst the dam. The pressure, and hence the total force, depends only on the depth of the water. If Boulder Dam were built right in front of a cliff in such a way that Lake Mead backed up only a few miles behind the dam instead of more than 100 miles, the bursting force would be the same – provided the depth were the same in both cases.

EXAMPLE: As an application of the equation, consider the following problem:

A U-tube is partly filled with water. Another liquid, which does not mix with water, is poured into one side until it stands a distance d above the water level on the other side, which has meanwhile risen a distance x . Find the density of the liquid relative to that of water.

Solution: Points C are at the same pressure. Hence, the pressure drop from C to each surface is the same, for each surface is at atmospheric pressure.

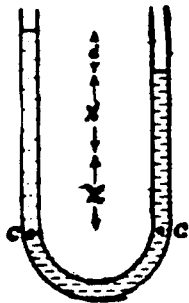

The pressure drop on the water side is $\rho_w g 2x$; the $2x$ comes from the fact that the water column has **risen** a distance x on one side and **fallen** a distance x on the other side, from its initial position. The pressure drop on the other side, is $\rho g (d + 2x)$, where ρg is the weight density of the unknown liquid. Hence,

$$\rho_w g 2x = \rho g (d + 2x)$$

and

$$\rho / \rho_w = (2x) / (2x + d)$$

Properties of Matter

The ratio of the density of a substance to the density of water is called the relative density or specific gravity of that substance.

Pascal's Principle

When a fluid is at rest, the difference of pressure between two points depends only on the difference of level and density. Hence, if the pressure at any point is increased, there will be an equal increase of pressure at every point, provided the density does not change. In addition to the pressure attributable to its weight, a confined fluid may be subjected to an additional pressure by the application of an external force. When the atmospheric pressure P_0 increases on the free surface of a liquid, the pressure at any depth must increase by the same amount. The same result holds if we cover the top surface with a piston and press down on it. This result was stated by the French scientist Blaise Pascal (1623 – 1662) and is called **Pascal's principle**. It is usually given as follows: Pressure applied to an enclosed fluid is transmitted undiminished to every portion of the fluid and the walls of the containing vessel. This result is a necessary consequence of the laws of fluid mechanics, rather than an independent principle.

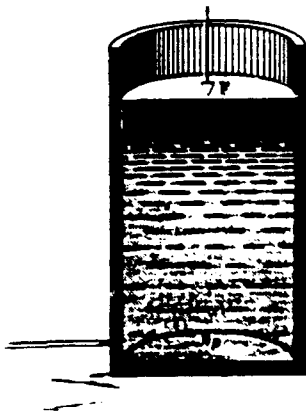

If the fluid is incompressible, a change in pressure in one portion of the fluid is transmitted instantaneously to all other parts. In a compressible fluid the pressure change in one part propagates through the fluid as a wave at the speed of sound in that fluid. Once the disturbance has died out and equilibrium is re-established, it is found that Pascal's principle is valid for a compressible fluid also. Changes in temperature accompany changes in pressure in a compressible fluid.

A fluid in a cylinder fitted with a movable piston. The pressure at point p is due not only to the weight of the fluid above p but also to the force exerted by the piston.

Measurement of Pressure

Evangelista Torricelli (1608–1647) devised a method for measuring the pressure of the atmosphere by his invention of the mercury barometer in 1643. The mercury barometer is a long glass tube that has been filled with mercury and then inverted in a dish of mercury.

The space above the mercury column contains only mercury vapor whose pressure is so small at ordinary temperatures that it can be neglected. It is easily shown that the atmospheric pressure P_0 is

$$P_0 = \rho gh$$

Properties of Matter

Most pressure gauges use atmospheric pressure as a reference level and measure the difference between the actual pressure and atmospheric pressure, called the **gauge pressure**. The actual pressure at a point in fluid is called the **absolute pressure**. Gauge pressure is given either above or below atmospheric pressure. A gauge that reads pressures below atmospheric is usually called a vacuum gauge.

The pressure of the atmosphere at any point is numerically equal to the weight of a column of air of unit cross-sectional area extending from that point to the top of the atmosphere. The atmospheric pressure at a point, therefore, decreases with altitude. There are variations in atmospheric pressure from day to day since the atmosphere is not static. The mercury column in the barometer will have a height of about 76 cm at sea level, varying with the atmospheric pressure. A pressure equivalent to that exerted by exactly 76 cm of mercury at 0°C under standard gravity, $g = 32.174 \text{ ft/sec}^2 = 980.665 \text{ cm/sec}^2$, is called **one standard atmosphere (1 atm)**. The density of mercury at this temperature is 13.595 gm/cm^3 . Hence, one standard atmosphere is equivalent to

$$\begin{aligned} 1 \text{ atm} &= (13.5950 \text{ gm/cm}^3)(980.665 \text{ cm/sec}^2) \\ &\quad (76.00 \text{ cm}) \\ &= 1.013 \times 10^5 \text{ nt/meter}^2 \\ &= 2116 \text{ lb/ft}^2 \\ &= 14.70 \text{ lb/in}^2. \end{aligned}$$

Often pressures are specified by giving the height of mercury column, at 0°C under standard gravity, which exerts the same pressure. This is the origin of the expression "centimeters of mercury" or "inches of mercury" pressure. Pressure is the ratio of force to area, however, and not a measurement of length.

Instead of mercury, water could be used in the barometer. It should be clear by now that (because water has a lower weight density than mercury) the column would have to be much taller. Whereas a column of mercury 29.92 inches high can be supported by atmospheric pressure, the column in a water barometer would be 34 feet high!

Atmospheric pressure will vary over the face of the earth due to the varying depths of our atmosphere.

Very often we do not realize that air has weight any more than we are conscious of atmospheric pressure. But air is made up of a mixture of oxygen (21 per cent), nitrogen (77 per cent), and gases (water vapor, carbon dioxide, argon, etc. 2 per cent), which have mass, and are therefore attracted to the earth by gravity. A cubic foot of air weighs a little more than an ounce. A small room 10 x 10 x 10 feet, contains 75 pounds of air.

It is the weight of the air that causes atmospheric pressure – as it is the weight of the water that causes pressure at the bottom of the ocean. We can calculate that the atmosphere would extend to a

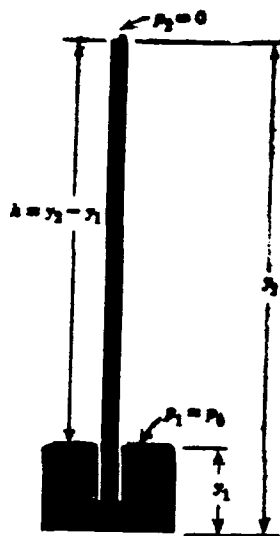

Properties of Matter

height of about five miles above the surface of the earth if the weight density remained the same as at sea level all the way to the top. In reality as we ascend above the surface, the density of the air decreases rapidly at first; then gradually trails off to nothing at a height of hundreds of miles.

No definite limit can be set to the depth of our atmospheric ocean. We do know, however, that half of all the air lies below an altitude of 3.5 miles.

Tables have been prepared for properties of the atmosphere as functions of altitude above sea level. These so-called *Standard Atmosphere Tables* are very useful for evaluating parameters like pressure and mass density. A Standard Atmosphere Table is provided in the Appendix of this text.

We have stated that atmospheric pressure can support a column of water 34 feet high. This distance, 34 feet, is of very practical importance to anyone who is planning to pump water from a well with the aid of a suction pump, or who wishes to siphon water over an obstacle. A suction pump does not really suck water up a pipe. Air pressure on the outside pushes the water up when the pump creates a partial vacuum inside the pipe. The air pressure cannot force the water up farther than 34 feet, because at that height, the weight of the column of water just balances the weight of the atmosphere. In actual practice, a lift of about 28 feet is considered good performance for a suction pump at sea level, because the pump cannot create a perfect vacuum. So if you dig a well and find that the water level is deeper than 28 feet, you should plan to install a force pump instead of a suction pump.

Similarly, it is useless to try to siphon water over a hill more than 34 feet high. The siphon, too, depends for its action on the pressure of the atmosphere. As you no doubt know, the siphon is a device which first lifts a liquid and then deposits it to a level lower than the starting point. This last qualification, "lower than the starting point," is important. In contradiction to the Principle of the Conservation of Energy, we should be getting something for nothing if a siphon would lift water from a lower to a higher level. You cannot siphon water out of a well or out of the bottom of a leaky boat.

It is interesting to study in detail the action of a siphon. Consider an inverted U-shaped tube with one end immersed in a vessel of water, and the other end, open to the air, hanging over the side of the vessel. Once the tube is initially filled with water by suction or other means, water will continue to flow out of the vessel until one of two things happens: either the water level in the vessel falls below the immersed end of the tube; or the level of the water outside rises to the level of the water inside. The question is: just why does this flow take place?

Suppose we imagine the water in the inverted U-tube to be replaced by a snug-fitting, nearly-frictionless cable, of just the length of the tube. The longer end of the cable on the outside of the vessel would outweigh the shorter end; and, as a result, the cable would slide through the tube, with the long end pulling the short end behind. Now, our cable analogy is bad in one respect: the cohesive forces of water are small, and the long column of water cannot actually pull the short column along after it. But suppose that the cable were cut just at the top of the bend in the U-tube. Then, as the long end of the cable began to fall out of the tube, a vacuum would be formed between the cut ends. Air pressure would push the short end along after the long end, just as though the cable were still

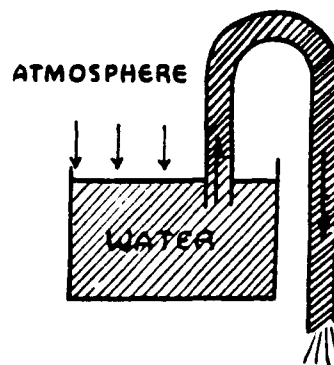

Properties of Matter

uncut. In exactly the same way, air pressure on the surface of the water in the vessel pushes water up the tube when the long column falls out the open end. The greater the difference in height between the open end of the tube and the water level in the vessel, the greater is the net pressure – hence, the greater the speed of flow.

The **open-tube manometer** measures gauge pressure. It consists of a U-shaped tube containing a liquid, one end of the tube being open to the atmosphere and the other end being connected to the system whose pressure P we want to measure.

$$P - P_0 = \rho gh$$

Thus the gauge pressure, $P - P_0$, is proportional to the difference in height of the liquid columns in the U-tube. If the vessel contains gas under high pressure, a dense liquid-like mercury is used in the tube; water can be used when low gas pressures are involved.

Our concern is in the use of and conversion between the various systems of pressure measurement.

To go from a gauge pressure reading to an absolute pressure, simply add the atmospheric pressure value. In equation form:

$$P_{\text{absolute}} = P_{\text{gauge}} + P_{\text{atmospheric}}$$

The other common systems of measurement as previously mentioned are expressed in pounds per square foot (psf), inches of mercury (in Hg), inches of water (in H₂O).

In addition to measuring pressures which are greater than atmospheric, we can measure pressures which are less. No trouble is encountered if these are absolute pressures. If they are gauge pressures then they are usually expressed as so many inches of mercury vacuum. This is subtracted from the atmospheric pressure to obtain the absolute pressure.

It is quite often found that pressures which are measured in one of the units mentioned previously has to be converted to other units for other calculations.

The following chart will provide a handy reference of the common systems in use:

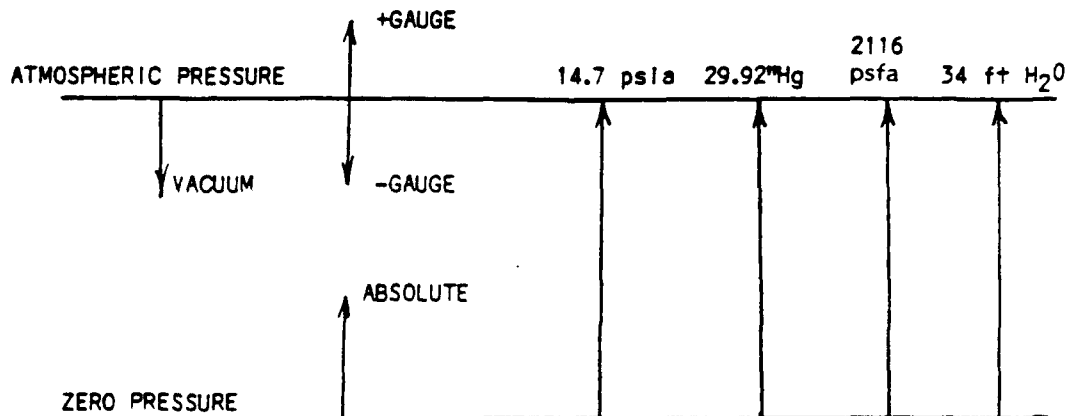

Properties of Matter

EXAMPLE Before we leave our discussion of pressure, a final example will demonstrate several of these latest comments.

An open-tube mercury manometer (see the previous figure) is connected to a gas tank. The mercury is 39.0 cm higher on the right side than on the left when a barometer nearby reads 75.0 cm of Hg. What is the absolute pressure of the gas? Express the answer in centimeters of Hg, atm, and lb/in².

SOLUTION: The gas pressure is the pressure at the top of the left mercury column. This is the same as the pressure at the same horizontal level in the right column. The pressure at this level is the atmospheric pressure (75.0 cm of Hg) plus the pressure exerted by the extra 39.0 cm column of Hg, or a total of 114 cm of Hg. Therefore, the absolute pressure of the gas is

$$114 \text{ cm of Hg} = (114/76) \text{ atm} = 1.50 \text{ atm} = (1.50)(14.7) \text{ lb/in}^2 = 22.1 \text{ lb/in}^2$$

What is the gauge pressure of the gas?

3.2 Density

We have been working so far without defining one of our terms. That term, weight density, is used in calculating pressures as we have seen. The density of matter is defined as the amount of matter contained within a unit volume. This amount can be either expressed in terms of mass units or weight units whichever is more convenient. Thus,

$$\begin{aligned} \text{mass density } (\rho) &= \text{mass/volume} = M/V \text{ (slugs/ft}^3\text{)} \\ \text{weight density } (\rho_g) &= \text{weight/volume} = W/V \text{ (lbs/ft}^3\text{)} \end{aligned}$$

The reciprocals of these two definitions are called the **specific volumes**.

The mass density ρ of a homogeneous fluid (its mass divided by its volume) may depend on many factors, such as its temperature and the pressure to which it is subjected. For liquids the density varies very little over wide ranges in pressure and temperature, and we can safely treat it as a constant for our purposes. The density of a gas, however, is very sensitive to changes in temperature and pressure. The fact that ρ is a variable for a gas complicates the treatment of gas mechanics.

For convenient reference, density tables for some common gases, liquids, and solids are provided in the Appendix.

3.3 Temperature

The sense of touch is the first and simplest way to distinguish hot bodies from cold bodies. By touch we can roughly arrange bodies in the order of their hotness, deciding that A is hotter than B, B than C, etc. We speak of this as our temperature sense. This is a very subjective and qualitative procedure for determining the temperature of a body and certainly not very useful for purposes of science. An old and simple experiment, suggested in 1690 by John Locke, shows the unreliability of this method. Let two hands be immersed, one in hot water, the other in cold. Then let both hands be placed in water of intermediate hotness. It will seem cooler to the first hand and warmer to the second hand. Our judgement of temperature can be rather misleading. Furthermore, the range of our temperature sense is limited. What we need is an objective, and preferably numerical, measure of temperature.

Properties of Matter

To begin with, we should try to understand the meaning of temperature. Let an object **A** which feels cold to the hand and an identical object **B** which feels hot be placed in contact with each other. After a sufficient length of time, **A** and **B** give rise to the same temperature sensation. Then **A** and **B** are said to be in **thermal equilibrium** with each other. We can generalize the expression "two bodies are in thermal equilibrium" to mean that the two bodies are in states such that, if the two were connected, the combined systems would be in thermal equilibrium. The logical and operational test for thermal equilibrium is to use a third or test body, such as a thermometer. This is summarized in a postulate often called the **Zeroth Law of Thermodynamics**: If **A** and **B** are in thermal equilibrium with a third body **C**, then **A** and **B** are in thermal equilibrium with each other.

This discussion expresses the fundamental idea that the temperature of a system is a property which eventually attains the same value as that of other systems when all these systems are put in contact. This concept is in accord with the everyday idea of temperature as the measure of the hotness or coldness of a system, because as far as our temperature sense can be trusted, the hotness of all objects becomes the same after they have been in contact long enough. It should be emphasized that the idea contained in the Zeroth Law, although simple, can hardly be called obvious. For example, Jones and Smith each know Green, but they may or may not know each other. Two pieces of iron, **A** and **B**, attract a magnet **C**, but they may or may not attract each other. Hence, it is necessary to express this idea concretely so that we can set up a rational procedure for measuring temperature.

The sensation of hot or cold is certainly an unreliable measure of temperature, but there is no record that the learned men of ancient times knew any better way of measuring it. One of the first thermometers was invented by our old friend Galileo. His simple device was scarcely more satisfactory than the sense of touch, because the reading varied with the atmospheric pressure as well as with temperature. But Galileo did not know this. His thermometer consisted of a long-necked glass flask, inverted, with the neck partly immersed in water. A little of the air in the flask was allowed to bubble out; so that the height of the column of water in the neck rose and fell as the air in the flask contracted and expanded.

Gas thermometers, acting on this same principle but with the effect of changes in atmospheric pressure eliminated, are still used today. They are, in fact, the most accurate of all thermometers, and are employed in laboratories for standardization; but they would hardly be convenient for everyday use.

There are many physical properties which change with temperature. Among these are the volume of a liquid, the length of a rod, the electrical resistance of a wire, the pressure of a gas kept at constant volume, the volume of a gas kept at constant pressure, and the color of a lamp filament. Any of these properties can be used in the construction of a thermometer.

Our common thermometers depend on the expansion of a liquid like mercury or alcohol (the alcohol is dyed red so that it can be seen easily). The greater part of the liquid is contained in a glass bulb; but as the bulb is heated, a small thread of the liquid rises in a glass tube of small bore. The glass bulb itself expands as it becomes hotter; but the liquid expands more rapidly, and this excess expansion of the liquid gives us the temperature reading on the scale.

All solids expand when they are heated; though the expansion is less than for liquids. You are aware, perhaps, that cracks are left in cement pavement, in steel bridges, and between the ends of

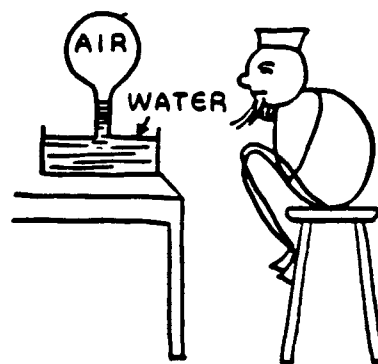

Galileo's thermometer.

Properties of Matter

rails, in order to allow for expansion at high temperature. A steel bridge a thousand feet long may be about a foot longer in summer than in winter. If provision were not made for expansion, such a structure might buckle.

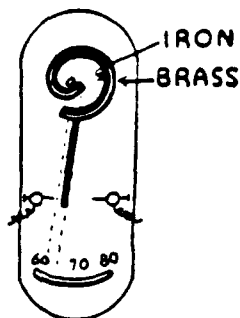

Thermostats, for opening and closing electrical circuits, for controlling the size of a gas flame in ovens and water heaters, and for many other purposes, commonly make use of the expansion of metals. One type of thermostat depends on the unequal expansion of two different metals. Brass, for example, expands more than iron. So if a strip of brass and a strip of iron are firmly riveted together at one temperature, the combination becomes curved at any other temperature. The iron side will be concave at a higher temperature, the brass side at a lower temperature. Obviously, such a bimetallic strip may be made to serve as a switch for turning on or off an electric current at a designated temperature.

But to return to the subject of temperature measurement: Whatever the method chosen, a standard temperature scale must be provided, if the reading of the thermometer is to mean anything. The various temperature scales in common use today are entirely arbitrary. Two fixed and reproducible points have been chosen; then the temperature interval between these two points has been divided into a number of sub-intervals or degrees.

The choice of fixed points presented a real problem to the early makers of thermometers. All sorts of standards were suggested, including the melting point of butter, body temperature, and the temperature of warm milk fresh from the cow. But nowadays, the freezing point of water, and the boiling point of water at atmospheric pressure at sea level, are the universal standards. On the Celsius scale (the one used in most European countries except England, and in all scientific work), ice melts at 0° , and water boils at 100° .

On the Fahrenheit scale, which is the one commonly used in the United States and England, ice melts at 32° , and water boils at 212° . The interval between freezing and boiling is thus divided into 212 minus 32 , or 180 degrees.

Although today the Fahrenheit scale is based on the freezing and boiling points of water, this was not always so. When Fahrenheit first devised the scale named after him, he chose as 0° the lowest temperature that he could obtain in the laboratory at that time—the temperature of a mixture of ice and salt. The other fixed point was normal body temperature, which he called 24° . Later, Fahrenheit's degree was divided into four parts, making body temperature 96° instead of 24° . Our modern scale has apparently been shifted somewhat, because normal body temperature is now 98.6°F .

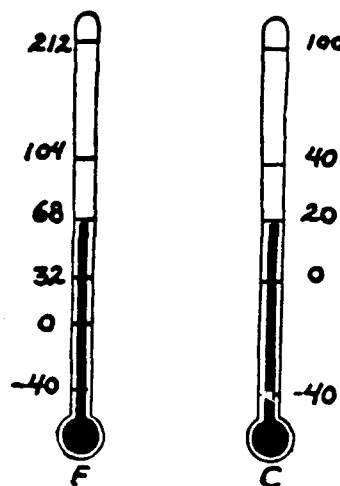

It should be obvious that one Fahrenheit degree does not equal one Celsius degree. In reality, it takes a temperature change of 180 Fahrenheit degrees to go from the freezing point to the boiling

Properties of Matter

point of water. The same is accomplished in 100 Celsius degrees. Therefore, each Celsius degree is equal to 9/5 Fahrenheit degrees.

To convert between the two scales, the following equations should be used.

$$F = (9/5)C + 32$$

$$C = (5/9)(F - 32)$$

Clearly, what we are trying to do is measure something (temperature) with several scales. Its like measuring lengths in feet or meters. Which is preferred? As it turns out, for engineering applications, we need a scale based on something even more basic than the freezing point of water. We need a scale referenced from the temperature at which all molecular motion is minimized. This is referred to as *absolute zero*. Conversion between the absolute and relative temperature scales has been determined to be

$$^{\circ}\text{F}_{\text{absolute}} = ^{\circ}\text{F} + 460$$

$$^{\circ}\text{C}_{\text{absolute}} = ^{\circ}\text{C} + 273$$

The Fahrenheit absolute scale is referred to as the **Rankine** scale, and the Celsius absolute scale is referred to as the **Kelvin** scale. These scales are used practically exclusively in engineering work.

3.4 Heat

What is the distinction between temperature and heat? Heat is something contained in a body, which makes the body hot. Lack of heat means that the body is cold. Temperature is a measure of the contained heat, but is not in itself heat.

Today we are well aware that heat is a form of energy. In the light of present-day knowledge, this fact is so self-evident that physicists are inclined to make uncomplimentary remarks about the diehards of scarcely a century ago who still believed that heat is an imponderable (weightless) fluid. But this *caloric theory of heat*, as it was called, was by no means a bad theory in many respects. People knew, for example, that heat flows from a hot body to a cold body, and that eventually both bodies come to the same temperature. This was easy to explain: a hot body contains more of the heat fluid (caloric) than a cold body; and the fluid flows from hot to cold. Again, people knew that it takes more heat (caloric) to raise the temperature of a pound of water 10° than a pound of iron, the water just naturally had a higher caloric content than the iron. In fact, the caloric theory could be made to explain almost all that was known about heat except one thing, the production of heat by friction.

When you apply the brakes to stop your automobile, the friction between drums and bands develops considerable heat. Prolonged application makes the drums very hot and may cause smoking and burning of the bands. But, normally, there is very little permanent change in either bands or drums. Nor does any other body in the neighborhood become cooler. Therefore, the heat cannot very well be something (a fluid?) contained in the materials and simply liberated by the friction. Rather, it must be something created by the friction – something that appears when the kinetic energy of the automobile is decreased.

Many carefully performed laboratory experiments (similar in principle to the heating of the brakebands and drums by friction) finally demonstrated to even the most skeptical that each time mechanical energy disappears as a result of friction, a corresponding amount of heat is produced.

Properties of Matter

Later, a similar equivalence between electrical energy and heat was discovered. The conclusion was inescapable that heat must be a form of energy.

Now, heat is usually measured in **calories**, a purely arbitrary unit chosen on the basis of most useful substance in early heat measurement – water. The calorie is the quantity of heat required to raise one gram of water through a temperature of one degree Celsius.

The number of calories needed to raise one gram of any substance through a temperature of one degree Celsius is called specific heat. The **specific heat** of water is one calorie per gram. The specific heat of most other materials is less than for water. Grain alcohol, for instance, has a specific heat of only 0.6 calorie per gram. The high specific heat of water makes oceans and lakes great reservoirs of heat energy – a fact of special significance in the determination of weather conditions.

If you are ready to agree that heat is a form of energy it still remains to be explained just how this energy is stored up in a material. The answer is simple: heat is contained in the form of atomic or molecular motion. A hot stove feels uncomfortable to the touch, because the atoms of the iron are vibrating rapidly and are transferring some of their energy by direct contact to the atoms and molecules of your fingers, stimulating the nerves. The molecules of a solid or a liquid cannot readily move very far; hence, their heat energy is stored up principally in the form of vibratory motion. This is not true in a gas. Consequently, a study of the behavior of gases gives us a simple insight into the true nature of heat energy.

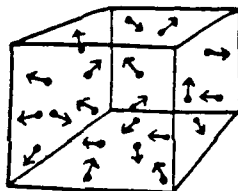

The kinetic theory picture of a gas. Molecules moving at random create pressure by collision with each other and with the walls.

According to the kinetic theory, a gas consists of myriads of inconceivably small molecules, all darting frantically hither and yon at a high rate of speed. The molecules collide with one another and with solid surfaces, bouncing off like perfectly elastic billiard balls. It is this continuous rain of billions upon billions of molecules pounding against a surface that is the ultimate cause of gas pressure.

The speed of the molecules depends on the temperature. At 0°C , air molecules on the average travel at the tremendous rate of 1100 miles per hour and each molecule makes more than five billion collisions with its neighbors (or against the walls of the containing vessel) each second. The total heat energy of the gas is simply the kinetic energies of all the separate molecules added together. As the temperature is raised, the kinetic energy is increased, the molecules move faster, and a greater pressure is created by the bombardment against the walls. As the gas is cooled, it loses heat energy. The average speed of its molecules decreases. At -273°C (-460°F), all molecular motion would theoretically cease, and the volume as well as the pressure of the gas would theoretically become zero. This temperature is known as absolute zero. In practice, before absolute zero is reached, all real gases first liquefy, then solidify. Oxygen, for example, condenses to a liquid at -183°C . Helium, the most difficult of all gases to liquefy, boils at -269° – only 4° above absolute zero.

Sometimes, the large calorie, or kilogram calorie, is employed as a unit of heat energy. This is equivalent to 1000 of the gram calories we discussed earlier. The energy provided by various foods is

Properties of Matter

usually expressed in terms of the large calorie. When you say, for example, that a pound of butter contains 3500 calories, you mean that when the butter is completely burned up by oxidation, 3500 large calories of heat will be produced. This energy is not present as heat in the butter itself, of course – so much heat would be more than enough to melt and vaporize the butter. The energy appears only when the butter combines chemically with oxygen. Meanwhile, it is stored-up chemical energy.

Transfer of Heat

Since heat is contained in a substance as molecular motion, it is not surprising that this motion is transferred from a hot body to a cold body by direct contact. Fast-moving molecules tend to speed up their slower neighbors on collision. This method of heat transfer is called, simply, **conduction**. Some materials are good conductors of heat; some are poor. Generally speaking, metals are excellent conductors; and the best conductors of electricity are also the best conductors of heat. Thus aluminum, a good electrical conductor, is likewise a good conductor of heat; and aluminum pots and pans (particularly the heavy cast ones) are excellent for cooking purposes, because they heat rapidly and uniformly. On the other hand, materials like wool, sand, asbestos, cork, and still air are poor conductors of heat; hence they are valuable for insulation of our houses, our refrigerators, and our bodies against either heat or cold.

In gases and liquids another process of heat transfer is very effective; namely, **convection**, or the rising of heated fluids. This is seen in drafts in chimneys, and in the shimmery appearance of the air above hot objects. Wind is usually caused by convection currents in the atmosphere. Likewise, gliders can rise to an altitude of thousands of feet and can fly many miles with the aid of updrafts in the atmosphere. Such convection currents moving either up or down cause the unpleasant “bumps” in the air that often annoy airplane passengers, and even make them airsick.

So much for the transfer of heat through material media. We also receive heat through empty space from the sun. Evidently not all the heat in the universe is stored up in the form of atomic and molecular motion. As a matter of fact, every object – hot or cold – constantly emits long wave length infra-red heat rays. To our other two means of heat transfer – conduction and convection – we must therefore add a third very important method; namely, **radiation**. While transfer of heat by conduction or convection requires the presence of a material medium, heat radiation travels most readily through empty, evacuated space. Radiation may, however, be transmitted through any medium that does not absorb it.

All objects emit heat rays; but it is a matter of everyday experience that hot objects radiate more heat than do cold ones. The quantity of energy radiated increases very rapidly with increased temperature. In fact, it goes up as the fourth power of the absolute temperature. This means that doubling the absolute temperature results in $(2)^4$, or 16, times as much emitted radiation.

An object at the same temperature as its surroundings absorbs heat just as fast as it loses heat. But things exposed to the rays of a hot body like the sun become continually warmer until conduction, convection, and radiation combined, serve to carry off heat as fast as it is absorbed. For example, a thermometer bulb, exposed to direct sunlight, becomes much hotter than the surrounding air. This is the reason why temperatures are always recorded as “so many degrees in the shade.” A reading taken with the thermometer in the sun has no real significance.

Some materials, particularly those of a dull, dark color, are good heat absorbers; that is, they absorb nearly all the heat that falls on them and reflect very little. On the other hand, things that are light-colored or shiny reflect most of the radiation and absorb very little.

Properties of Matter

The pipes and tanks of solar water heaters are always painted a flat black in order that they may absorb as much heat as possible from the sun's rays. Dark-colored roofs and clothes should be avoided, however, if you wish to keep cool in the summer time. People in the tropics usually wear white clothes to minimize absorption of heat. But dark clothes will help you to keep warm in the winter sun. Similarly, ice and snow will disappear from an asphalt pavement before they will from white concrete. The dark asphalt absorbs more heat. Snow will often melt away from under a leaf sooner than it will out in the open, because the dark leaf is a better absorber than the white snow exposed directly to the sun. In cities, old snow surfaces are pitted and uneven, the bottom of the pits being composed of specks of soot or dust that have been heated by the sun's radiation and have melted the snow below them.

Because of a peculiar property of glass, the interior of a greenhouse is maintained by radiation at a temperature well above the outside. The glass, being transparent to visible light, admits sunlight to the greenhouse. The light is largely absorbed by the plants and other objects inside. These, in turn, re-radiate the energy; but, being cool, they emit only long wave length heat rays. Glass is opaque (nontransparent) to this heat radiation; hence, the energy is partially trapped inside the greenhouse. The heat can escape by conduction through the walls, but not by radiation.

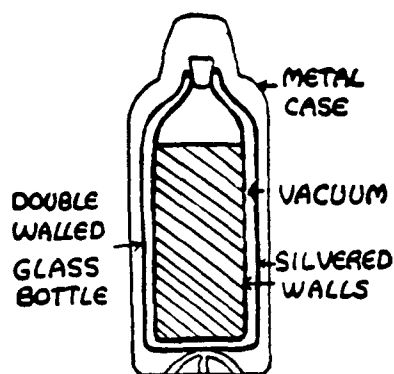
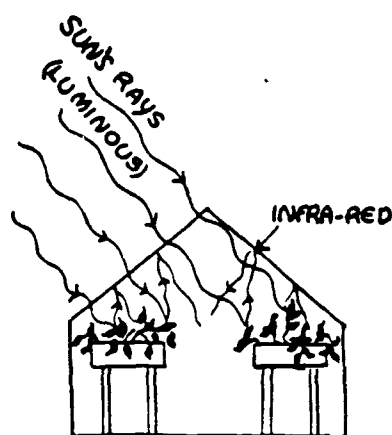

Construction of the thermos bottle.

A high degree of heat insulation is attained in thermos bottles, which picnickers and others find so valuable for keeping coffee hot or lemonade cold. The bottles are double-walled, with the air evacuated from the space between. The vacuum prevents loss of heat by conduction or convection, except in a small region around the neck. Radiation, either inward or outward, is largely eliminated by silvering the walls. Shiny surfaces, you recall, are poor absorbers of heat. Vacuum bottles of this type are the most efficiently insulated vessels known; but they are rather expensive, especially in the larger sizes. The lower-priced food jugs do not keep things hot or cold nearly so long, because they have no evacuated space. They are merely porcelain containers surrounded by some heat-insulating material.

A word about the apparent radiation of cold: You have probably held your hand up close to a piece of ice and have gained the impression that the ice was radiating a blast of cold, just as a hot stove radiates heat. Actually, the ice radiates heat – but your hand (at a higher temperature) radiates more heat. Hence, heat radiated (and conducted) from your hand is not compensated by a return flow from the ice. Your hand feels cold because it is continuously losing more heat than it gains.

Properties of Matter

3.5 Viscosity

When a block of wood slides across a surface, we know that there are forces which tend to resist the motion of the block. We call these forces **friction**.

In fluid motion the same thing happens. Let us look at a fluid flowing past a wall. The figure to the right shows how the velocity of the fluid varies from the wall outward.

The velocity at the wall is zero and increases to the freestream value. Between successive layers of fluid the same condition exists as between the wood block and surface since each successive layer is moving relative to its neighbor. One layer is offering a frictional resistance to the motion of the other. We call this internal fluid friction **viscosity**.

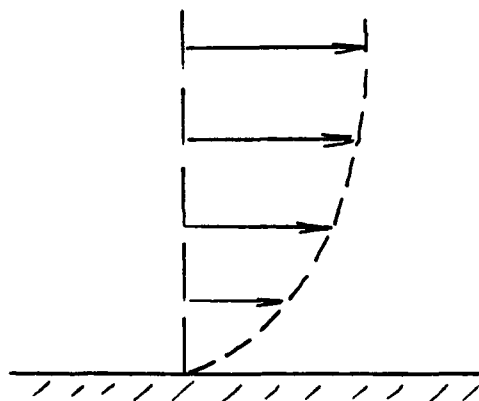

Viscosity usually increases rapidly as a liquid becomes colder. Thus, the oil in your automobile engine is thick on cold mornings, and the starter has difficulty in cranking the motor. The Society of Automotive Engineers (S.A.E.) ratings for motor oil are based on viscosity. A light winter oil of S.A.E. rating 10 or 20 is much less viscous (thick) than is a heavy summer oil of rating 40 or 50. Since the lubricating properties of an oil depend partly on its viscosity, a good oil must hold its "body" at high temperatures, and not become too thin and watery. In other words, the viscosity of the oil should not change too greatly as the motor heats up. Oils containing a large proportion of wax are particularly bad in this respect, because the viscosity of wax decreases rapidly at high temperature.

3.6 Momentum

If you have ever pulled the trigger of a loaded shotgun or high-powered rifle, you know that the gun kicks back sharply when it is fired. When you jump out of a rowboat onto a pier, the boat recoils in the opposite direction, and you may get wet if you are not careful. In a sense these are illustrations of Newton's Third Law of Motion; action and reaction are equal. Better yet, they are examples of the **Conservation of Momentum** – an important mechanical principle based on Newton's Laws of Motion.

Momentum is sometimes called quantity of motion. More precisely it is defined as the product of mass times velocity:

$$\text{Momentum} = MV$$

A loaded freight car has greater mass and, therefore, more momentum than an empty car, provided both are moving at the same speed. But a fast-moving empty car may have more momentum than a slow-moving loaded car. The mass of the empty car is relatively small, but at high speed its MV is great. Velocity tells us how fast an object is moving. Momentum tells us the effort required to get it moving.

Now, it requires force in order to change momentum. This should be evident if we recall that Newton's Second Law demands a force for the acceleration of any object. If an automobile is accel-

Properties of Matter

erated, its momentum increases as its velocity increases. A matter of fact, Newton himself stated the Second Law in terms of momentum change rather than acceleration. He said that the amount of change of momentum is proportional to the force acting.

It is further evident that the momentum of a single body or of an isolated group of bodies must remain constant when the externally applied forces are small enough to be neglected. If a gun and its bullet, for example, are initially at rest, their momentum is zero. Firing the gun does not change that situation. The total momentum is still zero. The forces are **internal** rather than **external**, and the momentum of the bullet in one direction just balances the momentum of the gun in the opposite direction. We might write a single equation to express this fact:

$$\begin{array}{cc} mV = Mv \\ \text{(bullet)} & \text{(gun)} \end{array}$$

The bullet has small mass and large velocity; the gun of large mass kicks back with relatively small velocity.

3.7 Ideal Gas

It is found from experiment that all gases behave essentially in the same way provided their densities are not too high. That is, if the temperatures are not too low and the pressures are not too high, all real gases show the same simple behavior. This suggests the concept of an ideal gas, one that will have this simple behavior under all conditions. Let us first deduce the **ideal gas law**.

Methods exist for measuring the pressure (**P**), the volume (**V**), the temperature (**T**), and the mass (**m**), of a gas. We call **V/m** the **specific volume**. Consider now experiments carried out on a gas at low density. Such experiments lead to the result that **at a constant temperature the pressure of a gas is inversely proportional to its specific volume (Boyle's law); and that the product of the pressure and the specific volume is directly proportional to the temperature (Charles' law)**. These experimental results can be summarized by the relation

$$\frac{PV}{m} = kT$$

where **k** is a constant of proportionality whose value depends on the specific gas being investigated.

When we compare the values of **k** for various gases, we find from experiment that **k** is inversely proportional to the molecular weight **m** of the gas. That is, we find that **k = \bar{R}/m** , where **\bar{R}** is a constant of proportionality, the same for all gases. Hence, **\bar{R}** is not specific to a particular gas but is a universal constant. We can therefore rewrite the above equation

$$\frac{PV}{m} = \frac{\bar{R}T}{m}$$

where

- P** = absolute pressure in (lbf/ft²)
- V** = gas volume in (ft³)
- m** = gas mass in (lbm)
- \bar{R}** = Universal gas constant = 1545 (ft³/°R)
- m** = molecular weight of the gas
- T** = absolute temperature in (°R)

Properties of Matter

EXAMPLE Lets look at an example of how the ideal gas equation can be used:

A cylinder contains oxygen gas at a temperature of 60°F and a pressure of 14.7 psi in a volume of two cubic feet. If a fitted piston is lowered into the cylinder, decreasing the gas volume to 0.75 cubic feet and raising the temperature to 72°F. What then is the new gas pressure?

Solution: We can write the ideal gas equation as

$$\frac{PV}{T} = \frac{m\bar{R}}{m}$$

Since the mass (and the make-up) of the gas is unchanged, $\frac{m\bar{R}}{m}$ is constant and we have

$$\frac{P_1V_1}{T_1} = \frac{P_2V_2}{T_2}$$

Our initial conditions are $P_1 = 14.7$ psi
 $V_1 = 2$ ft³
 $T_1 = 60^\circ\text{F} = 520^\circ\text{R}$
and our final conditions are $P_2 = ?$
 $V_2 = 0.75$ ft³
 $T_2 = 72^\circ\text{F} = 532^\circ\text{R}$

Plugging these values into our equation and solving for P_2

$$P_2 = \frac{T_2}{T_1} \frac{P_1V_1}{V_2} = 40.1 \text{ psi}$$

The Perfect Gas Law expresses only the relationship between pressure, temperature, and specific volume at a particular point. If we have a gas at some state 1 for which $P_1v_1 = RT_1$ and by some process we take the gas to some other state 2 where, $P_2v_2 = RT_2$ then we have

$$\frac{P_1v_1}{T_1} = \frac{P_2v_2}{T_2} = R$$

where

$$v = \frac{V}{m}$$

$$R = \frac{\bar{R}}{m}$$

This suggests that we can plot all processes on a P - v - T diagram. What is usually done in practice is to plot Pressure versus Specific Volume with Temperature as a third variable as shown on the next page.

Properties of Matter

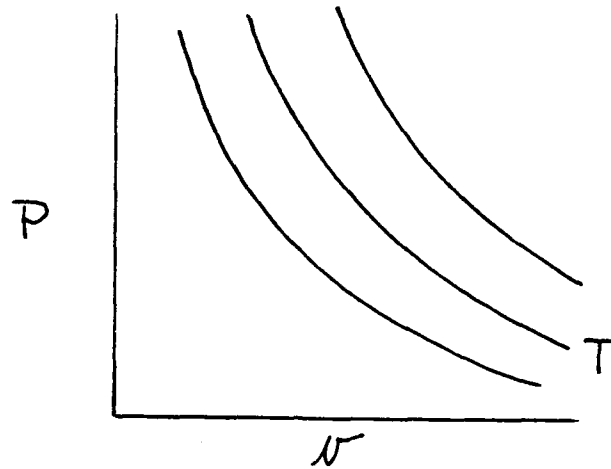

With the use of this diagram we can trace all the states of a gas during any particular process. Three simple processes are shown below.

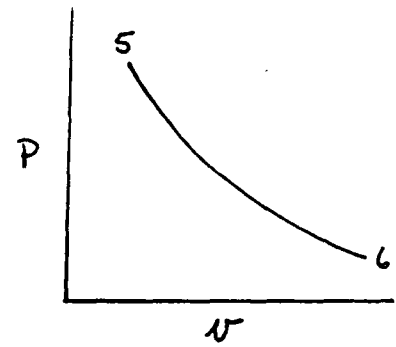
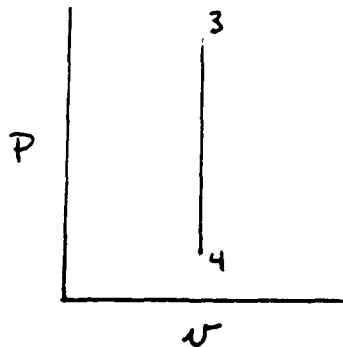
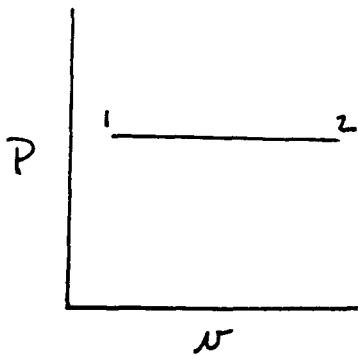

For each of the above processes the Perfect Gas Law provides a relationship between the other properties at any point during the process. Thus, for a constant pressure process,

$$\frac{T_2}{T_1} = \frac{v_2}{v_1}$$

Properties of Matter

for a constant volume process,

$$\frac{P_4}{P_3} = \frac{T_4}{T_3}$$

for a constant temperature process,

$$\frac{P_6}{P_5} = \frac{v_5}{v_6}$$

Miscellaneous but Essential Terminology

Before proceeding further, some additional terminology is necessary.

1. **Specific Heat** – the specific heat of a substance is the amount of heat required to raise the temperature of one pound one degree during a particular process. There are two specific heats to consider:

- a. specific heat during a constant pressure process, C_p .

$$\text{For air } C_p = .240 \text{ BTU/lbm}^\circ\text{R}$$

- b. specific heat during a constant volume process, C_v .

$$\text{For air } C_v = .1715 \text{ BTU/lbm}^\circ\text{R}$$

In engineering practice, we often encounter the ratio of these specific heats. It's called by the Greek letter gamma (γ).

$$\gamma = C_p/C_v = 1.4 \text{ for air}$$

2. **Speed of Sound** – the mechanism by which sound travels through a compressible medium is mainly by molecular motion. Thus, as you talk your vocal chords vibrate and set the molecules of air adjacent to them into motion. This motion is transmitted from molecule to molecule by successive collisions until it reaches the listener's ear. Therefore, the speed at which this sound travels must be a function of the kinetic energy of the molecules. The kinetic energy can in turn be shown to be a function of the absolute temperature. The exact appearance of this function for a perfect gas has been found to be by both analysis and experiment:

$$a_c = \sqrt{gRT\gamma}$$

where a_c = speed of sound in ft/sec

g = gravitational constant 32.2 ft/sec²

R = gas constant of the particular gas

γ = specific heat ratio (1.4 for air)

T = absolute temperature in $^\circ\text{R}$

The speed of sound in air at standard sea level conditions comes out to be $a_c = 1116 \text{ ft/sec} = 761 \text{ mi/hr}$.

Properties of Matter

3. **Mach Number** – Mach number is defined as the ratio of the local velocity to the local speed of sound.

$$M = \text{Vel}/a_c$$

The use of Mach Number divides all compressible flow into two major divisions. Those velocities which are less than the speed of sound are called subsonic ($M < 1$). Flows which have speeds greater than the speed of sound ($M > 1$) are called supersonic. We can also talk of the transonic regime for velocities near the speed of sound ($.8 < M < 1.2$) and the hypersonic regime for velocities many times the speed of sound ($M > 6$).

CHAPTER IV THE GOVERNING LAWS OF ROCKET PROPULSION

4.1 Newton's First Law of Motion

Man quite naturally appeals to his everyday experiences in seeking to understand nature. As far as motion is concerned, he sees, among many other things, falling stones, sliding blocks, bullets shot from rifles, and the apparent motions of the heavenly bodies. By studying these motions he hopes to find fundamental laws that apply to all or at least to many of his experiences involving motion.

During ancient times and throughout the Middle Ages, Aristotle was the standard authority on most scientific matters. Today we can scarcely understand how anyone, let alone an authority, could be wrong so often. But Aristotle and the other Greek philosophers were observers and thinkers; they had no conception of the modern experimental point of view. Hence they often arrived at false scientific conclusions.

When Aristotle said that the natural state of all matter is a state of rest, he was correct as far as his observations went. Anyone can see that a stone thrown into the air, or a ball rolled along the ground, soon comes to a stop.

But what happens if the stone were located out in space a million miles from the influence of the earth? Would it come to rest then, or would it keep moving? Aristotle did not know. He and his contemporaries could think of no way to find out.

Galileo (1564 – 1642), who is often called the father of modern experimental science, found the answer to this and to many other perplexing questions. In fact Galileo, almost single-handed, changed the whole outlook of the little world of science by the middle of the seventeenth century. He stressed experiment rather than philosophy. Galileo asked first, **What happens?** and only afterwards, **Why does it happen?** Before one can explain the motion of a stone projected into space, one must first determine just how the stone moves under various circumstances.

In the year of Galileo's death, one of the greatest scientists of all time, Sir Isaac Newton, was born. Like Galileo, Newton was an able experimenter. But he was more than an experimenter. He possessed a rare genius that enabled him to see far beyond the immediate results of his and Galileo's observations. He was able to generalize, to draw broad inferences, and to discover rules and laws that were to serve as a basis for scientific developments in the centuries to come. He carried to full fruition the ideas of Galileo and others who preceded him. His system of mechanics is summarized in three laws of motion, presented first (in 1686) in the *Principia Mathematica Philosophiae Naturalis*.

Before Galileo's time most philosophers thought that some external influence or "force" was needed to keep a body moving. They thought that a body was in its "natural state" when it was at rest. In order for a body to move in a straight line at constant speed, for example, they believed that some external agent had to continually propel it, otherwise it would "naturally" stop moving.

If we wanted to test these ideas experimentally, we would first have to find a way in which to free a body from all external influences, or forces. We would soon find that we really cannot do this, because even bodies very far from our test body can influence it and change its motion. However, in certain cases we can make the external forces very small. If we study the motion as we make these forces smaller and smaller, we shall have some idea of what the motion would be like if the external forces were truly zero.

Governing Laws

We cannot remove the earth but we can minimize its influence on motion by placing our test body, say a block, on a rigid horizontal plane. If we let the block slide along this plane, we notice that it gradually slows down and stops. This observation was used, in fact, to support the idea that motion stopped when the external force, in this case the hand initially pushing the block, was removed. Galileo argued against this idea, however. His reasoning was as follows.

Let us repeat our experiment, now using a smoother block and a smoother surface. We notice that the velocity decreases more slowly than before. Let us continue to use still smoother blocks and surfaces. We find that the block decreases in velocity at a slower rate and travels farther each time before coming to rest. We can now extrapolate our ideas and say that if all friction could be eliminated, the body would continue indefinitely in a straight line with constant speed. This was Galileo's conclusion. Galileo asserted that some external force was necessary to change the velocity of a body but that no external force was necessary to maintain the velocity of a body. Our hand, for example, exerts a force on the block when it sets it in motion. The rough plane exerts a force on the block when it slows the block down. Both of these forces produce a change in the velocity, that is, they produce an acceleration.

This principle of Galileo was adopted by Newton as the first of his three laws of motion. Newton stated his first law of motion in these words: "Every body persists in its state of rest or of uniform motion in a straight line unless it is compelled to change that state by forces impressed on it."

The First Law of Motion obviously contradicts Aristotle's concept that the natural state of all bodies is a state of rest. Newton said that an object will keep on moving at constant speed in a straight line unless some kind of a push or a pull force like gravitation or friction is applied to it. Thus a stone thrown into the air is pulled back to earth by gravity; and when the stone strikes the ground, its rolling or sliding motion is stopped by frictional forces. If there were such a thing as a truly frictionless surface, the stone would slide on indefinitely at a constant speed.

We know that the planets revolve around the sun with unchanging orbits. The planets, of course, are subject to the force of gravitation. Otherwise, according to Newton's First Law, they would fly off on a straight line into space. But their speeds of rotation remain constant, because there is practically no friction force to slow them down.

It is important to realize that this principle has not actually been proved but that it represents a generalization from experience. We often use this procedure in science. Whether or not the procedure is a good one depends on whether or not the deductions from the generalization agree with experiment.

In order to prove Newton's First Law we need to define the word "force" which appears in the statement of the law. So far we have not done so. Rather we have loosely identified force with what we call external influence. In so doing we have leaned heavily on the intuitive feeling that all of us have about the nature of force. In science, however, our concepts must rest on a firmer foundation than intuitive feelings. They must be defined in a quantitative, operational way. Logically, we could take the First Law as a definition of force. Force would thereby be defined as the cause of acceleration. This definition would not be a quantitative one, however, although it would be in accord with our intuitive ideas about force.

Governing Laws

4.2 Newton's Second Law of Motion

The fact that a body once started in motion retains a uniform linear motion in the absence of applied forces is often described by assigning a property to matter called mass. Mass is regarded then as the property of matter that determines its resistance to a change in its motion.

The procedure for measuring mass is suggested by experience. For a given force, the greater the mass the less the acceleration produced by that force. We now generalize this experience and define mass in terms of the acceleration produced by a given force. To be exact, if m_1 is the mass of body 1 and m_2 is the mass of body 2, we define the ratio of the masses to be

$$m_1/m_2 = a_2/a_1 \quad (\text{given force } F)$$

where a_2 is the magnitude of the acceleration of body 2 and a_1 is the magnitude of the acceleration of body 1 produced by the same applied force F . If body 2 has only half the acceleration of body 1 when both are acted on by the same force, then by definition m_2 is twice as great as m_1 . If m_1 is the standard mass, then m_2 would be two standard masses.

If we were to change the force from F to F' and once again measure the ratio of accelerations produced on the same two bodies 1 and 2 as used before, we would find

$$a_2'/a_1' = a_2/a_1$$

so that

$$m_1/m_2 = a_2/a_1 = a_2'/a_1'$$

The ratio of the masses is found to be the same, regardless of the particular force we use in the experiments. Since the masses are accelerated different amounts by different forces, we conclude that the mass of a body, as we have defined it, is independent of the velocity of the body.

Furthermore, experiment shows that we can consistently assign mass numbers to any body by this procedure. For example, if we compare a third body with body 1 and find m_3 from the relation

$$m_1/m_3 = a_3/a_1 \quad (\text{given force } F)$$

experiment shows that when body 2 and 3 are compared

$$a_3/a_2 = m_2/m_3 \quad (\text{given force } F)$$

where m_2 and m_3 are the values already determined by comparing bodies 2 and 3 independently with body 1.

In order to find a number to assign for the mass of a body, we simply agree to assign a standard object a mass of one unit. Then the masses of all other objects are defined in terms of this unit mass. We, therefore, have an operational procedure for measuring mass quantitatively, a procedure which is simple, self-consistent, and intuitively satisfactory.

We can now summarize all the experiments and definitions in one equation, the fundamental equation of classical mechanics,

$$\vec{F} = m\vec{a}$$

Governing Laws

In this equation \vec{F} represents the (vector) sum of all the forces acting on the body, m is the mass of the body, and \vec{a} is its (vector) acceleration. That all our results are contained in this one equation is obvious from the form

$$\vec{a} = \vec{F}/m$$

which states that the acceleration caused by one or many forces acting on a body is proportional in magnitude to the resultant of the forces, and parallel to it in direction, and is inversely proportional to the mass of the body. This can be taken as a statement of Newton's Second Law of motion.

Notice that the first law of motion is contained in the Second Law as a special case, for if $\vec{F} = 0$, then $\vec{a} = 0$. In other words, if the resultant force on a body is zero, the acceleration of the body is zero. Therefore, in the absence of applied forces, a body will move with constant velocity or be at rest (zero velocity). This is the exact content of the first law of motion. Therefore, of Newton's three laws of motion only two are independent, namely the second and the third.

Notice that the above equation is a **vector** equation. We can write this single vector equation as three **scalar** equations,

$$\begin{aligned}F_x &= m a_x \\F_y &= m a_y \\F_z &= m a_z\end{aligned}$$

relating the x , y , and z components of the resultant force (F_x , F_y , and F_z) to the x , y , and z components of acceleration (a_x , a_y , a_z) for the mass m . It should be emphasized that F_x is the sum of the x components of all the forces, F_y is the sum of the y components of all the forces, and F_z is the sum of the z components of all the forces acting on m .

Mass is a scalar quantity. It follows from experiment that if objects of mass m_1 and m_2 are fastened together, they behave mechanically as a single object of mass ($m_1 + m_2$).

Newton expressed the Second Law of motion in a more general way than we have. To quote him, "**The change of motion is proportional to the motive force impressed, and is made in the direction of the right (that is, straight) line in which that force is impressed.**" Newton's term "motion" is called momentum today and is the quantity mv . Hence, Newton states that the force acting on a body is equal to the rate of change of momentum of the body, or in our terminology, $F = \Delta(mv)/\Delta t$. If we assume that the mass of a body is constant in time, this equation becomes

$$\vec{F} = \frac{\Delta(m\vec{v})}{\Delta t} = \frac{m\Delta\vec{v}}{\Delta t} = m\vec{a}$$

4.3 Newton's Third Law of Motion

Forces acting on a body originate in other bodies. Any single force is only one aspect of a mutual interaction between two bodies. We find that whenever one body exerts a force on a second body, the second body always exerts a force on the first. Furthermore, these forces are equal in magnitude but opposite in direction. A single isolated force is, therefore, an impossibility.

Governing Laws

One of the two forces involved in the interaction between two bodies is called an "action" force, the other force is called the "reaction" force. Either force may be considered the "action" and the other the "reaction." Cause and effect is not implied here, but a mutual simultaneous interaction is implied.

This property of forces was first stated by Newton in his Third Law of motion: "To every action there is always opposed an equal reaction; or, the mutual actions of bodies upon each other are always equal, and directed to contrary parts."

In other words, if body A exerts a force on body B, body B exerts an equal but oppositely directed force on body A; and furthermore the forces lie along the line joining the bodies. It is important to notice that the action and reaction forces, which always occur in pairs, act on different bodies. If they were to act on the same body, we could never have accelerated motion because the resultant force on every body would always be zero.

Imagine a boy kicking open a door. The force exerted by the boy on the door accelerates the door (it flies open); at the same time, the door exerts an equal but opposite force on the boy, which decelerates the boy (his foot loses forward velocity). The boy will be painfully aware of the "reaction" force to his "action," particularly if his foot is bare.

The following example illustrates the application of the third law and clarifies its meaning.

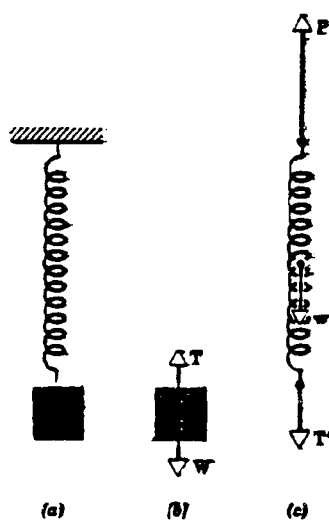

(a) A block is suspended by a spring. (b) A free-body diagram showing all the vertical forces exerted on the block. (c) A similar diagram for the vertical forces on the spring.

Consider a spring attached to the ceiling and at the other end holding a block at rest. Since no body is accelerating, all the forces on any body will cancel. For example, the forces on the suspended block are T , the tension in the stretched spring, pulling vertically up on the mass, and W , the pull of the earth acting vertically down on the body, called its weight. These are drawn in Fig. b, where we show only the block for clarity. There are no other forces on the block.

The resultant of all the forces acting on the block is $\vec{T} + \vec{W}$. In Newton's Second Law, \vec{F} represents the sum of all the forces acting on a body, so that for the block

$$\vec{F} = \vec{T} + \vec{W}$$

The block is at rest so that its acceleration is zero, or

$$\vec{a} = 0$$

Hence, from the relation

$$\vec{F} + m\vec{a}$$

we obtain

$$\vec{T} + \vec{W} = 0$$

Governing Laws

or

$$\vec{T} + -\vec{W}$$

The forces act along the same line, so that their magnitudes are equal, or

$$T = W$$

Therefore, the tension in the spring is an exact measure of the weight of the block.

It is instructive to examine the forces exerted on the spring also. \vec{T}' is the pull of the block on the spring and is the reaction force of the action force \vec{T} . \vec{T}' , therefore, has the same magnitude as \vec{T} , which is W . \vec{P} is the upward pull of the ceiling on the spring, and \vec{w} is the weight of the spring, that is, the pull of the earth on it. Since the spring is at rest and all forces act along the same line, we have

$$\vec{P} + \vec{T}' + \vec{w} = 0, \text{ or} \\ P = W + w.$$

The ceiling, therefore, pulls up on the spring with a force whose magnitude is the sum of the weights of the block and spring.

From the third law of motion, the force exerted by the spring on the ceiling, \vec{P}' , must be equal in magnitude to \vec{P} , which is the reaction force to the action force \vec{P} . \vec{P}' , therefore, has a magnitude $W + w$.

In general, the spring exerts different forces on the bodies attached at its different ends, for $P' \neq T$. In the special case in which the weight of the spring is negligible, $w = 0$, and $P' = W = T$. Therefore, a weightless spring (or cord) may be considered to transmit a force from one end to the other without change.

Lets look at the action/reaction pairs in the above problem. The reaction to \vec{W} , a force exerted by the earth on the block, must be a force exerted by the block on the earth. Similarly, the reaction to \vec{w} is a force exerted by the spring on the earth. Because the earth is so massive, we do not expect these forces to impart a noticeable acceleration to the earth. Since the earth is not shown in our diagrams, these forces have not been shown. The forces T and T' are action-reaction pairs, as are \vec{P} and \vec{P}' . Notice that although $\vec{T} + -\vec{W}$ in our problem, these forces are not an action-reaction pair because they act on the same body.

Some Applications of Newton's Laws of Motion

Newton's Second Law states that the vector sum of all the forces acting on a body is equal to the mass of the body times its acceleration. Hence, the first step in problem solving is to pick the body to be considered. As obvious as this seems, lack of clarity as to what exactly has been or should be picked for the body leads to more mistakes than any other point in setting up problems. Once the body has been picked, we next determine all the forces acting on the body. It is helpful to make a separate diagram showing only the body picked and all the force acting on it. This is called a **free-**

Governing Laws

body diagram. Next, we pick a convenient reference system and apply Newton's Second Law to each component of force and acceleration.

The following examples illustrate the applications of Newton's laws of motion. Each body is treated as if it were a particle of definite mass, and the forces acting on it are assumed to act at a point. The acceleration of gravity is taken to be 32.0 ft/sec^2 or $9.80 \text{ meters/sec}^2$ unless otherwise specified. Strings and pulleys are considered to have negligible mass.

EXAMPLE

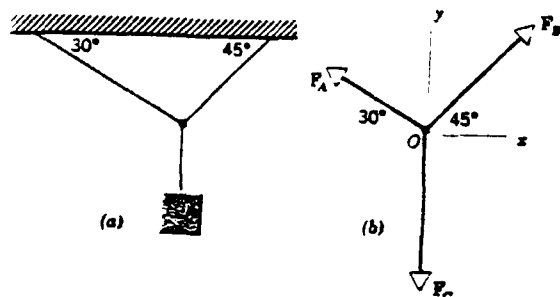

(a) A mass is suspended by strings. (b) A free-body diagram showing all forces acting on the knot. The strings are assumed to be weightless.

The figure above shows a weight hung by strings. Consider the knot at the junction of the three strings to be the body. The body remains at rest under the action of the three forces shown in Fig. b. Suppose we are given the magnitude of one of these forces. How can we determine the magnitude of the other forces?

\vec{F}_A , \vec{F}_B , and \vec{F}_C are all the forces acting on the body. Since the body is unaccelerated (actually at rest), $\vec{F}_A + \vec{F}_B + \vec{F}_C = 0$. Choosing the x - and y -axes as shown, we can write this vector equation equivalently as three scalar equations:

$$\begin{aligned} F_{Ax} + F_{Bx} &= 0 \\ F_{Ay} + F_{By} + F_{Cy} &= 0 \end{aligned}$$

The third scalar equation for the z -axis is simply

$$F_{Az} = F_{Bz} = F_{Cz} = 0$$

That is, the vectors all lie in the x - y plane and have no z components. From the figure we see that

$$\begin{aligned} F_{Ax} &= -F_A \cos(30^\circ) = -0.866 F_A \\ F_{Ay} &= F_A \sin(30^\circ) = 0.500 F_A \\ F_{Bx} &= F_B \cos(45^\circ) = 0.707 F_B \\ F_{By} &= F_B \sin(45^\circ) = 0.707 F_B \\ F_{Cy} &= -F_C = -W \end{aligned}$$

because the string C merely serves to transmit the force on one end to the junction at its other end. Substituting these results into our original equations, we obtain

$$\begin{aligned} -0.866 F_A + 0.707 F_B &= 0 \\ 0.500 F_A + 0.707 F_B - W &= 0 \end{aligned}$$

If we are given the magnitude of any one of these three forces, we can solve these equations for the other two. For example, if $W = 100 \text{ lb}$, we obtain $F_A = 73.3 \text{ lb}$ and $F_B = 89.6 \text{ lb}$.

Governing Laws

EXAM. LE – We wish to analyze the motion of a block on a smooth incline.

(a) Static case: Figure a shows a block of mass m kept at rest on a smooth plane, inclined at an angle θ with the horizontal, by means of a string attached to the vertical wall. The forces acting on the block are shown Fig. b. \vec{F}_1 is the force exerted on the block by the string; $m\vec{g}$ is the pull of the earth on the block, that is, its weight; and \vec{F}_2 is the force exerted on the block by the inclined surface. \vec{F}_2 called the normal force, is normal to the surface of contact because there is no frictional force between the surfaces. If there was a frictional force, F_2 would have a component parallel to the incline. Note that the block will exert forces on other bodies (the string, the earth, the surface of the incline) in accordance with the action–reaction principle; these forces, however, are not needed to determine the motion of the block.

Suppose θ and m are given. How do we determine the values of F_1 and F_2 ? Since the block is unaccelerated, we obtain

$$\vec{F}_1 + \vec{F}_2 + m\vec{g} = 0$$

It is convenient to choose the x -axis to be normal to the incline (Fig. b). With this choice of coordinates, only one force, $m\vec{g}$ must be resolved into components in solving the problem. The two scalar equations obtained by resolving $m\vec{g}$ along the x - and y -axes are

$$\begin{aligned} F_1 - mg \sin(\theta) &= 0 \\ F_2 - mg \cos(\theta) &= 0 \end{aligned}$$

from which F_1 and F_2 can be obtained if θ and m are given.

(b) Dynamic case: Now suppose that the string is to be cut. Then the force F_1 , the pull of the string on the block, will be removed. The resultant force on the block will no longer be zero, and the block will, therefore, accelerate. What is its acceleration?

We have $F_x = ma_x$ and $F_y = ma_y$. Using these relations we obtain

$$\begin{aligned} F_2 - mg \cos(\theta) &= ma_y = 0 \\ -mg \sin(\theta) &= ma_x \end{aligned}$$

which yields

$$\begin{aligned} a_y &= 0 \\ a_x &= -g \sin(\theta) \end{aligned}$$

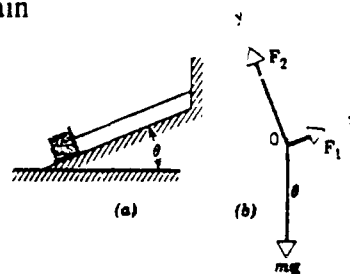

The acceleration is directed down the incline with a magnitude of $g \sin \theta$.

EXAMPLE– Figure (a) shows a block of mass m_1 on a smooth horizontal surface pulled by a string which is attached to a block of mass m_2 hanging over a pulley. We assume that the pulley has no mass and is frictionless and that it merely serves to change the direction of the tension in the string at that point. Find the acceleration of the system and the tension in the string.

Governing Laws

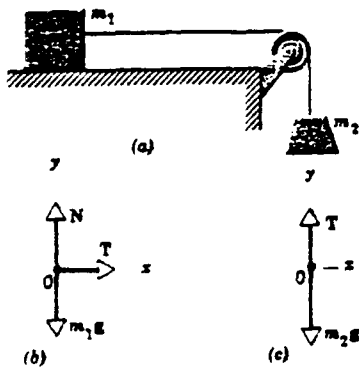

Suppose we choose the block of mass m_1 as the body whose motion we investigate. The forces on this block, taken to be a particle, are shown in Figure b. \vec{T} , the tension in the string, pulls on the block to the right; $m_1\vec{g}$ is the downward pull of the earth on the block and \vec{N} is the vertical force exerted on the block by the smooth table. The block will accelerate in the x direction only, so that $a_{1y} = 0$. We, therefore can write

$$\vec{N} - m_1\vec{g} = 0 = m_1\vec{a}_{1y}$$

$$\vec{T} = m_1\vec{a}_{1x}$$

From these equations we conclude only that $\vec{N} = m_1\vec{g}$. We do not know \vec{T} , so we cannot solve for \vec{a}_{1x} .

To determine \vec{T} we must consider the motion of the suspended block of mass m_2 . In fact, if \vec{T} were to equal $m_2\vec{g}$, the resultant force on the suspended block would be zero, a condition holding only if the system is not accelerated.

The equation of motion for the suspended block is

$$m_2g - T = m_2a_{2y}$$

It is clear that, because the string has a fixed length and because the direction of the tension in the string at the pulley changes,

$$a_{2y} = a_{1x}$$

and we can therefore represent the acceleration of the system as simply a . We then obtain

$$m_2g - T = m_2a$$

$$T = m_1a$$

These yield

$$m_2g = (m_1 + m_2) a$$

$$a = (m_2/(m_1 + m_2)) g$$

$$T = ((m_1 m_2)/(m_1 + m_2)) g$$

which gives us the acceleration of the system a and the tension in the string T .

Notice that the tension in the string is always less than m_2g . This is clear from the last equation which can be written

$$T = m_2 g m_1/(m_1 + m_2)$$

Notice also that a is always less than g , the acceleration due to gravity. Only when m_1 equals zero, which means that there is no block at all on the table, do we obtain $a = g$. In this case $T = 0$.

Governing Laws

EXAMPLE – Consider two unequal masses connected by a string which passes over a frictionless and massless pulley, as shown in Fig. a. Let m_2 be greater than m_1 . Find the tension in the string and the acceleration of the masses.

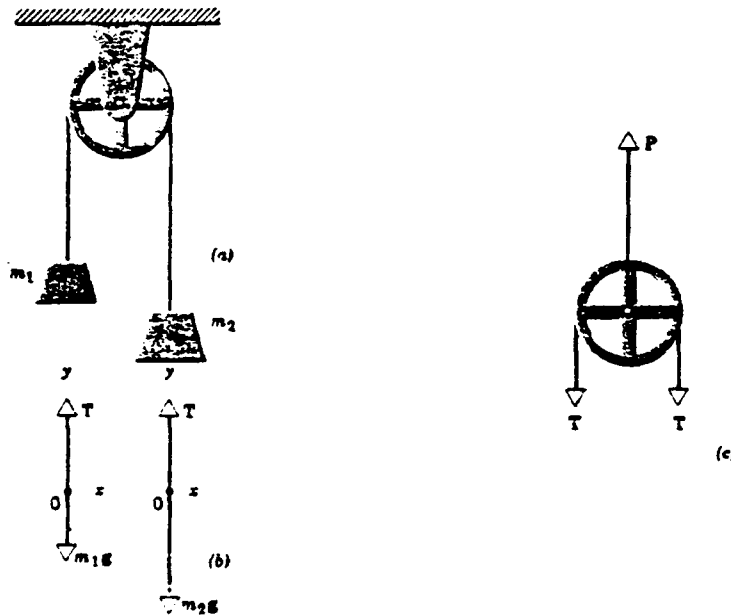

We consider an upward acceleration positive. If the acceleration of m_1 is a , the acceleration of m_2 must be $-a$. The forces acting on m_1 and on m_2 are shown in Fig. b in which T represents the tension in the string. The equation for m_1 is $T - m_1g = m_1a$ and for m_2 is $T - m_2g = -m_2a$

Combining these equations, we obtain

$$a = (m_2 - m_1)/(m_2 + m_1) * g$$

$$T = (2m_1m_2g)/(m_1 + m_2)$$

For example, if $m_2 = 2.0$ slugs and $m_1 = 1.0$ slug,

$$a = (32.2/3.0) \text{ ft/sec}^2$$

$$T = 4/3 * (32.2) \text{ slug ft/sec} = 43 \text{ lbs}$$

Notice that the magnitude of T is always intermediate between the weight of the mass m_1 (32.2 lb in our example) and the weight of the mass m_2 (64.4 lb in our example). This is to be expected, since T must exceed m_1g to give m_1 an upward acceleration, and m_2g must exceed T to give m_2 a downward acceleration. In the special case when $m_1 = m_2$, we obtain $a = 0$ and $T = m_1g = m_2g$, which is the static result to be expected.

Figure c depicts the forces acting on the massless pulley as a particle; all the forces can be taken to act through its center. P is the upward pull of the support on the pulley and T is the downward pull of each segment of the string on the pulley. Since the pulley has no translational motion,

$$P = T + T = 2T$$

If we were to drop our assumption of a massless pulley and assign a mass m to it we would then be required to include a downward force mg on the support. Also the rotational motion of the pulley results in a different tension in each segment of the string. Friction in the bearings also affects the rotational motion of the pulley and the tension in the strings.

Governing Laws

4.4 Conservation of Mass (Continuity Equation)

One way of describing the motion of a fluid would be to try the formidable task of following the motion of each individual particle in the fluid. We would give coordinates x, y, z to each fluid particle and specify these as functions of the time t . The coordinates x, y, z at the time t of the fluid particle which was at x_0, y_0, z_0 at the time t_0 would be determined by functions $x(x_0, y_0, z_0, t_0, t), y(x_0, y_0, z_0, t_0, t), z(x_0, y_0, z_0, t_0, t)$ which then describe the motion of the fluid. This procedure is a direct generalization of the concepts of particle mechanics and was first developed by Joseph-Louis Lagrange (1736–1813).

There is a treatment, developed by Leonard Euler (1707–1783), which is more convenient for most purposes. In it we give up our attempt to specify the history of each fluid particle and instead specify the density and the velocity of the fluid at each point in space at each instant of time. This is the method we shall follow here. We thus focus our attention on what is happening at a particular point in space at a particular time, rather than on what is happening to a particular fluid particle. Any quantity used in describing the state of the fluid, for example the pressure P , will have a definite value at each point in space and at each instant of time. Although this description of fluid motion focuses attention on a point in space rather than on a fluid particle, we cannot avoid following the fluid particles themselves, at least for short time intervals Δt . For it is the particles, after all, and not the space points, to which the laws of mechanics apply.

In order to understand the nature of the simplifications we shall make, let us consider first some general characteristics of fluid flow.

Fluid flow can be steady or nonsteady. When the fluid velocity \vec{v} at any given point is constant in time, the fluid motion is said to be steady. That is, at any given point in a steady flow the velocity of each passing fluid particle is always the same. At some other point the particle may travel with a different velocity, but every other particle which passes this second point behaves the same. These conditions can be achieved at low flow speeds. In nonsteady flow the velocities \vec{v} are a function of the time. In the case of turbulent flow the velocities vary erratically from point to point as well as from time to time.

Fluid flow can be rotational or irrotational. If the element of fluid at each point has no net angular velocity about that point, the fluid flow is irrotational. We can imagine a small paddle wheel immersed in the moving fluid. If the wheel moves without rotating, the motion is irrotational; otherwise it is rotational. Irrotational flow is important chiefly because it yields fairly simple mathematical problems. Angular momentum will play no role and \vec{v} is relatively simple. Rotational flow includes vortex motion, such as whirlpools or eddies, and motion in which the velocity vector varies in the transverse direction.

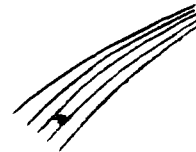

A small paddle wheel placed in a flowing fluid rotates in rotational flow and does not rotate in irrotational flow

Fluid flow can be compressible or incompressible. Liquids can usually be considered as flowing incompressibly. But even a compressible gas may sometimes undergo unimportant changes in density. Its flow is then practically incompressible. In flight, at speeds much lower than the speed of

Governing Laws

sound in air, the motion of the air relative to the wings is one of nearly incompressible flow. Ordinary subsonic aerodynamics is an example of incompressible flow. In such cases the density ρ is a constant, independent of x , y , z , and t , and the mathematical treatment of fluid flow is thereby greatly simplified.

Finally, fluid flow can be viscous or nonviscous. Viscosity in fluid motion is the analog of friction in the motion of solids. In some cases, such as in lubrication problems, it is extremely important. Often, however, it is negligible. When it is present, viscosity introduces tangential forces between layers of fluid in relative motion and results in dissipation of mechanical energy.

In steady flow the velocity \vec{v} at a given point is constant in time. Consider a point P within the fluid shown below. Since \vec{v} at P does not change in time, every particle arriving at P will pass on with the same speed in the same direction. The same is true about points Q and R . Hence, if we trace out the path of the particle, as is done in the figure, that curve will be the path of every particle arriving at P . This curve is called a **streamline**. A streamline is parallel to the velocity of the fluid particles at every point. No two streamlines can ever cross one another, for if they did, an oncoming fluid particle could go either one way or the other, and the flow could not be steady.

In principle we can draw a streamline through every point in the fluid. Let us select a finite number of streamlines to form a bundle, like the streamline pattern of the figure below. This tubular region is called a tube of flow. The boundary of such a tube consists of streamlines and is always parallel to the velocity of the fluid particles. Hence, no fluid can cross the boundaries of a tube of flow and the tube behaves somewhat like a pipe of the same shape. The fluid that enters at one end must leave at the other. In steady flow the pattern of streamlines in the fluid is stationary in time.

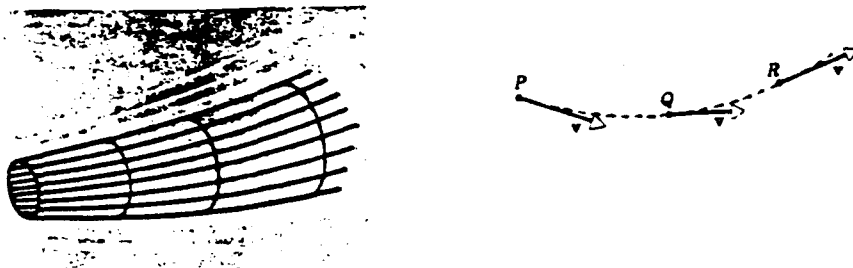

In the figure below we have drawn a thin tube of flow. The velocity of the fluid inside, although parallel to the tube at any point, may have different magnitudes at different points. Let the speed be V_1 for fluid particles at P and V_2 for fluid particles at Q . Let A_1 and A_2 be the cross-sectional areas of the tubes perpendicular to the streamlines at the points P and Q , respectively. In the time interval Δt a fluid element travels approximately the distance $V\Delta t$. Then the mass of fluid Δm crossing A_1 in the time interval Δt is approximately

$$\Delta m_1 = \rho_1 A_1 V_1 \Delta t$$

or the mass flux $\Delta m_1 / \Delta t$ is approximately

$$\frac{\Delta m_1}{\Delta t} = \rho_1 A_1 V_1$$



Governing Laws

We must take Δt small enough so that in this time interval neither V nor A varies appreciably over the distance the fluid travels. In the limit as $\Delta t \rightarrow 0$ we obtain the precise result

$$\frac{dm_1}{dt} = \rho_1 A_1 V_1 \quad \text{at P}$$

Now at Q the mass flux is correspondingly

$$\frac{dm_2}{dt} = \rho_2 A_2 V_2 \quad \text{at Q}$$

where ρ_1 and ρ_2 are the fluid densities at P and Q , respectively. Since no fluid can leave through the walls of the tube and there are no "sources" or "sinks" wherein fluid can be created or destroyed in the tube, the mass crossing each section of the tube per unit time must be the same. Hence,

$$\frac{dm_1}{dt} = \frac{dm_2}{dt}$$

or

$$\rho_1 A_1 V_1 = \rho_2 A_2 V_2$$

or

$$\rho AV = \text{constant.}$$

This result is called the equation of continuity of mass flow. It expresses the law of conservation of mass in fluid dynamics.

If the fluid is incompressible, then $\rho_1 = \rho_2$.

$$AV = \text{constant}$$

or

$$A_1 V_1 = A_2 V_2$$

The product AV gives the volume flux or flow rate, as it is often called. Notice that it predicts that in steady incompressible flow the speed of flow varies inversely with the cross-sectional area, being larger in narrower parts of the tube. The fact that the product AV remains constant along a tube of flow allows us to interpret the streamline picture somewhat. In a narrow part of the tube the streamlines must crowd closer together than in a wide part. Hence, as the distance between streamlines decreases, the fluid speed must increase. Therefore, we conclude that widely spaced streamlines indicate regions of low speed and closely spaced streamlines indicate regions of high speed.

We can obtain another interesting result by applying the Second Law of motion to the flow of fluid between P and Q . A fluid particle at P with speed V_1 must be decelerated in acquiring the smaller forward speed V_2 at Q . Hence, the fluid is decelerated in going from P to Q . The deceleration can come about from a difference in pressure acting on the fluid particle flowing from P to Q or from the force of gravity. In a horizontal tube of flow the gravitational force does not change. Hence, we can conclude that in steady horizontal flow the pressure is greatest where the speed is least.

Governing Laws

Were you ever in a crowd when it started to push its way through a small opened door? Outside in the back of the crowd the cross-sectional area was large, the pressure was great, but the speed of advance rather small. Through the door of small cross section the pressure was relieved and the speed of advance gratifyingly increased. This particular "human fluid" is compressible and viscous, of course, and the flow is sometimes turbulent and rotational.

4.5 Bernoulli's Equation

Consider the nonviscous, steady, incompressible flow of a fluid through the pipeline or tube of flow shown below.

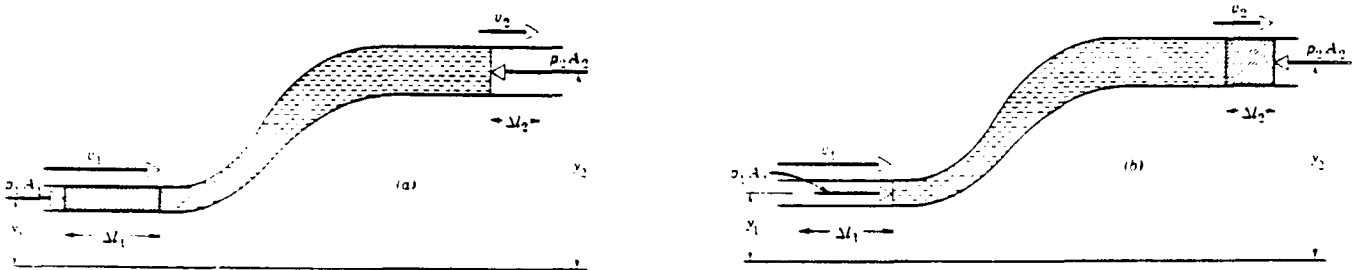

The portion of pipe shown in the figure has a uniform cross section A_1 at the left. It is horizontal there at an elevation Y_1 above some reference level. It gradually widens and rises and then at the right has a uniform cross section A_2 . It is horizontal there at an elevation Y_2 . Let us concentrate our attention on the portion of fluid represented by both cross-shading and horizontal shading and call this fluid the "system". Consider then the motion of the system from the position shown in (a) to that in (b).

At all points in the narrow part of the pipe, the pressure is P_1 and the speed V_1 . At all points in the wide part the pressure is P_2 and the speed V_2 . The left portion of the system (cross-shading) advances a distance Δl_1 parallel to an external force $P_1 A_1$ supplied by the fluid to its left, so that the work done on the system is.

$$P_1 A_1 \Delta l_1$$

The right portion of the system (cross-shading) advances a distance Δl_2 against an oppositely directed force $P_2 A_2$ supplied by the fluid beyond, so that the work done by the system is $P_2 A_2 \Delta l_2$. Hence, to move the system from position (a) to position (b), a net amount of work must be done on the system by the pressures applied to it equal to

$$P_1 A_1 \Delta l_1 - P_2 A_2 \Delta l_2$$

Now, $A_1 \Delta l_1$ and $A_2 \Delta l_2$ are the volumes of the two cross-shaded regions. These volumes are equal because the fluid is incompressible. In fact, if we let m be the mass of either cross-shaded region and take the fluid density to be ρ , then

$$A_1 \Delta l_1 = A_2 \Delta l_2 = \frac{m}{\rho}$$

Governing Laws

and

$$(P_1 - P_2) \frac{m}{\rho} = \text{net work done on system}$$

If our pipe has a continuously variable cross section, this analysis can be made exact by considering the process in the limit as ΔQ_1 , ΔQ_2 , and Δt shrink to zero at the points 1 and 2. The result is the same as before.

If the flow is nonviscous, the net work done on the system by pressure must equal the net gain in mechanical energy. The horizontal shaded portion of the fluid does not change at all in either kinetic or potential energy during the flow from (a) to (b). Only the cross-shaded portions contribute to changes in mechanical energy. In fact,

$$\frac{1}{2} m V_2^2 - \frac{1}{2} m V_1^2 = \text{net change of kinetic energy}$$

and

$$mgy_2 - mgy_1 = \text{net change in gravitational potential energy}$$

where m is the mass in either cross-shaded region. Hence,

$$(P_1 - P_2) \frac{m}{\rho} = \left(\frac{1}{2} m V_2^2 - \frac{1}{2} m V_1^2 \right) + (mgy_2 - mgy_1)$$

or on rearranging terms,

$$P_1 + \frac{1}{2} \rho V_1^2 + \rho gy_1 = P_2 + \frac{1}{2} \rho V_2^2 + \rho gy_2$$

Since the subscripts 1 and 2 refer to any two locations along the pipeline, we can drop the subscripts and write

$$P + \frac{1}{2} \rho V^2 + \rho gy = \text{constant}$$

This is called **Bernoulli's Equation** for steady, non-viscous, incompressible flow. It was first presented by Daniel Bernoulli (1700 - 1782) in his *Hydrodynamica* in 1738.

Bernoulli's equation is strictly applicable only to steady flow. The quantities involved must be evaluated along the same streamline; hence, the constant is not the same for all streamlines. In our figure the streamline used is along the central portion of the tube of flow or pipeline. It should come as no surprise that the law of pressure change with height of fluid at rest is included in Bernoulli's equation as a special case. For let the fluid be at rest; then $V_1 = 0 = V_2$ and

$$P_1 + \rho gy_1 = P_2 + \rho gy_2$$

or

Governing Laws

$$P_2 - P_1 = - \rho g(y_2 - y_1)$$

which we have seen before.

All terms have the dimension of a pressure. The pressure $P + \rho gh$, which would be present even if there were no flow, is denoted as P (the static pressure); the term $\frac{1}{2} \rho V^2$ is called dynamic pressure.

Applications of Bernoulli's Equation and the Continuity Equation

In general, Bernoulli's Equation is used to determine fluid velocities by means of pressure measurements. The principle generally used in such measuring devices is the following: The equation of continuity requires that the speed of the fluid at a constriction increase; Bernoulli's Equation then shows that the pressure must fall there. That is, for a horizontal pipe $P + \frac{1}{2} \rho V^2$ equals a constant; if V increases and the fluid is incompressible, P must decrease.

EXAMPLE

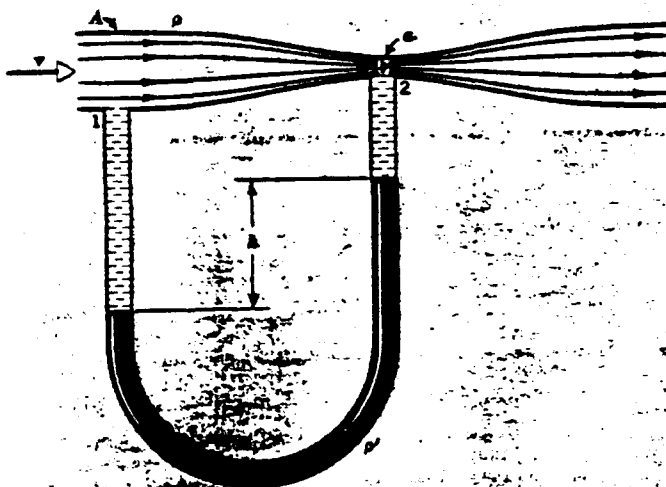

The Venturi meter is a gauge put in the flow pipe to measure the flow speed of a liquid. A liquid of density ρ flows through a pipe of cross-sectional area A . At the throat the area is reduced to B and a manometer tube is attached, as shown. Let the manometer liquid, such as mercury, have a density ρ' . By applying Bernoulli's Equation and the equation of continuity at points 1 and 2, the student can show that the speed of flow at A is

$$V = B \sqrt{\frac{2(\rho' - \rho)gh}{\rho(A^2 - B^2)}}$$

If we want the volume flux or flow rate Q , which is the volume of liquid transported past any point per second, we simply compute

$$Q = VA$$

EXAMPLE

The Pitot tube is used to measure the flow speed of a gas. Consider the gas, say air, flowing past the openings at a . These openings are parallel to the direction of flow and are set far enough back so that the velocity and pressure outside the openings have the free-stream values.

The pressure in the left arm of the manometer, which is connected to these openings, is then the static pressure in the gas stream, P_a . The opening of the

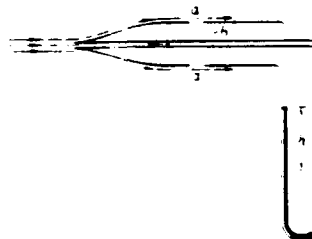

Governing Laws

right arm of the manometer is at right angles to the stream. The velocity is reduced to zero at **b** and the gas is stagnant at that point. The pressure at **b** is the full ram pressure, P_b . Applying Bernoulli's equation to points **a** and **b**, we obtain

$$P_a + \frac{1}{2}\rho V^2 = P_b$$

where, as shown in the figure, P_b is greater than P_a . If h is the difference in height of the liquid in the manometer arms and ρ' is the density of the manometer liquid, then

$$P_a + \rho'gh = P_b$$

Comparing these two equations, we find

$$\frac{1}{2}\rho V^2 = \rho'gh$$

or

$$v = \sqrt{\frac{2gh\rho'}{\rho}}$$

which gives the gas speed. This device can be calibrated to read v directly and is then known as an air-speed indicator.

EXAMPLE

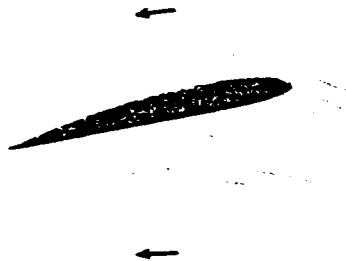

Consider the lift on an airplane wing. The figure shows the steady flow pattern past an airfoil, the cross section of an airplane wing, in a wind tunnel. Airfoils characteristically have a sharp trailing edge and greater curvature on the upper surface than on the lower. This shape results in a greater flow speed past the upper surface than past the lower, which can be seen from the streamline pattern in the figure. The crowding of the streamlines above the airfoil shows that the air speed there is greater than the free-stream speed.

The pressure on the top of the wing, therefore, drops below the free-stream pressure, by Bernoulli's law. On the bottom of the wing the flow speed is generally lower than the free-stream speed and the pressure is greater than the free-stream pressure. The pressure difference between the bottom and top surfaces results in an upward force, or lift.

If the angle between the flow direction and the airfoil is increased enough, the flow may cease to be steady and turbulence sets in. Then Bernoulli's Equation no longer holds. In fact, the pressure above the wing rises, the lift decreases, and the airplane may stall.

You can demonstrate Bernoulli's Principle for yourself in a rather spectacular fashion, with the aid of an ordinary spool, a common pin and a piece of cardboard about an inch square. Stick the pin through the center of the cardboard, and insert the pointed end of the pin into the hole of the spool. The cardboard then lies flat across the end of the spool and is prevented from slipping sideways by

Governing Laws

the pin. Now, holding the card in place momentarily, blow steadily on the other end of the spool. Instead of blowing the card away, the stream of air only makes the card stick to the spool and, paradoxically, the harder you blow, the closer the card sticks. Pressure in the air current between spool and card is reduced in accordance with Bernoulli's Principle. Atmospheric pressure on the other side of the card then pushes the card up tightly against the spool.

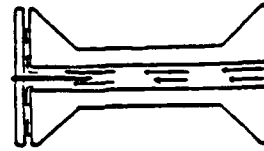

Besides aspirators, atomizers, and spray guns, there are other practical applications of Bernoulli's Principle. One of these is the carburetor on your automobile. Air, sucked into a cylinder on the downstroke of the piston, passes over a tube or jet, the lower end of which is immersed in gasoline. The pressure is reduced in the air blast and gasoline is pushed up the tube by the excess pressure of the relatively stationary surrounding air. The volatile liquid soon vaporizes and mixes with the air to form an explosive mixture.

4.6 Conservation of Momentum

The Principle of the Conservation of Momentum may be expressed as follows: When the external forces acting on a mechanical system can be neglected, the total momentum of the system remains constant. This comes from Newton's Second Law.

There are many examples of the conservation of momentum. When two billiard balls collide the momentum before impact always equals the momentum after impact. Thus the cue ball stops dead when it strikes another ball head on. The second ball takes up the momentum.

When billiard balls collide at a glancing angle momentum is still conserved, but account must be taken of the various directions involved. Balls made of inelastic material like putty or lead tend to stick together on collision. But momentum is still conserved with the MV of the two balls before impact equal to the MV after impact.

Conservation of momentum is sometimes of practical value. When you drive a nail into a thin wall you hold a heavy weight up behind in order to absorb the blow of the hammer and thus prevent the wall from giving under the impact. The massive weight moves very little even though it receives most of the momentum of the hammer.

Similarly, a circus strong man is able to withstand the blows of a sledge hammer on his chest or stomach. A block of concrete is placed on his chest, apparently for the purpose of making a more impressive demonstration of strength. Actually the heavy block cushions the blow of the sledge hammer because its velocity of recoil is small.

For a system of many parts, say a rocket, the total momentum is equal to the product of the total mass of the system and the velocity of the system's center of mass.



Some Applications of the Momentum Principle

EXAMPLE

Consider first a problem in which an external force acts on a system of particles. Let us imagine a shell that explodes in flight. The path of the shell is shown below. We assume that the air resistance is negligible. The system is the shell, the earth is our reference frame, and the external force is that of gravity. At the point X_1 the shell explodes and shell fragments are blown in all directions. What can we say about the motion of this system after the explosion?

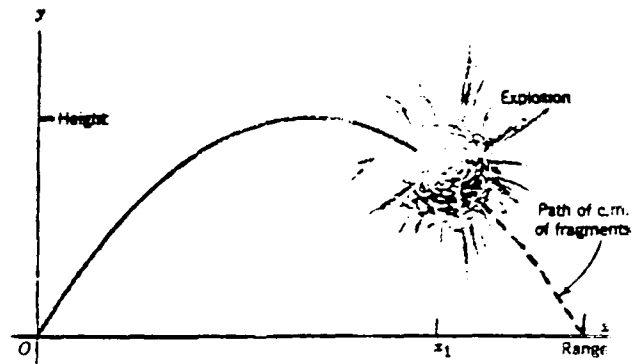

The forces of the explosion are all internal forces; they are forces exerted by part of the system on other parts of the system. These forces may change the momenta of all the individual fragments from the values they had when they made up the shell, but they cannot change the total vector momentum of the system. Only an external force can change the total momentum. The external force, however, is simply that due to gravity. Since a system of particles as a whole moves as though all its mass were concentrated at the center of mass with the external force applied there, the center of mass of the fragments will continue to move in the parabolic trajectory that the unexploded shell would have followed. The change in the total momentum of the system attributable to gravity is the same whether the shell explodes or not.

EXAMPLE

Consider now two blocks **A** and **B**, of masses M_A and M_B , coupled by a spring and resting on a horizontal frictionless table. Let us pull the blocks apart and stretch the spring, as shown below, and then release the blocks. Describe the subsequent motion.

If the system consists of the two blocks and spring, then after we have released the blocks there is no net external force acting on the system. The only forces are internal ones arising from the spring. These cancel in pairs when we are thinking about the system as a whole. We can, therefore, apply the conservation of linear momentum to the motion. The momentum of the system before the blocks were released was zero, so the momentum must remain zero thereafter. The total momentum can be zero even though the blocks move because momentum is a **vector quantity**. One block will have positive momentum (**A** moves in the $+x$ direction) and the other block will have negative momentum (**B** moves in the $-x$ direction). From the conservation of momentum we have

initial momentum = final momentum,

$$0 = M_B \vec{V}_B + M_A \vec{V}_A$$

Therefore,

$$M_B \vec{V}_B = -M_A \vec{V}_A$$

or

$$\vec{V}_A = -\frac{M_B}{M_A} \vec{V}_B$$

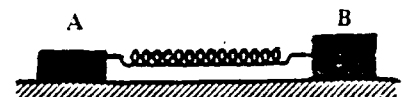

Governing Laws

For example, if M_A is 2 slugs and M_B is 1 slug, then \vec{V}_A is one-half \vec{V}_B and is oppositely directed.

EXAMPLE

Consider the apparently simple example of a ball thrown up from the earth by a person and then caught by him on its return. To simplify matters we can consider the person to be part of the earth since he does not lose contact with it. We also assume that air resistance is negligible.

The system being considered consists of the earth and the ball. The gravitational forces between the parts of the system are now internal forces. Let us choose a frame of reference in which the earth is at rest initially. When the ball is thrown up, the earth must recoil. The momentum of the system (earth + ball) is zero initially and no external forces act. Therefore, momentum is conserved and the total momentum remains zero throughout the motion. The upward momentum acquired by the ball is balanced by an equal and opposite downward momentum of the earth. We have

initial momentum = final momentum

$$0 = M_B \vec{V}_B + M_E \vec{V}_E$$

$$M_B \vec{V}_B = -M_E \vec{V}_E$$

Here M_B and M_E are the masses of ball and earth respectively and \vec{V}_B and \vec{V}_E are the velocities of the ball and the earth. Owing to the enormous mass of the earth in comparison with the ball, the recoil speed of the earth is negligibly small.

As the ball and earth separate, the internal force of gravitational attraction pulls them together until they cease separating and begin to approach one another. As the ball falls toward the earth, the earth falls toward the ball with an equal but oppositely directed momentum. As the ball is caught, its momentum is neutralized by (and it neutralizes) the momentum of the earth. Both objects lose their relative motion, the total momentum is still zero, and the original situation before throwing is restored.

4.7 First Law of Thermodynamics (Law of Conservation of Energy)

The Law of Conservation of Energy states that energy can neither be created nor destroyed in ordinary processes. It can, however, be transformed from one form to another. In other words, the total energy – kinetic plus potential plus heat plus all other forms – does not change. This statement is a generalization from our experience, so far not contradicted by our observation of nature. Often in history this principle has seemed to fail. But its apparent failure stimulated the search for the reasons. Scientists and physicists searched for physical phenomena besides motion that accompany the forces of interaction between bodies. Phenomena have always been found. With work done against friction, heat is produced in other interactions energy in the form of sound, light, electricity, etc., may be produced. Hence the concept of energy was generalized to include forms other than kinetic and potential energy of directly observable bodies. This procedure, which relates the mechanics of bodies observed to be in motion to phenomena which are not mechanical or in which motion is not directly detected, has linked mechanics to all other areas of physics. The energy concept now permeates all of the physical science and has become one of the unifying ideas of physics. It is during energy transformations that we measure the energy changes in terms of work, for it is during these transformations that forces arise and do work.

Governing Laws

Two terms have crept into our discussion of the energy equation: **kinetic energy** and **potential energy**.

Kinetic energy is defined as one-half of the product of the mass of a body and the square of its speed,

$$KE = 1/2 mv^2$$

Thus kinetic energy allows a body to do work by virtue of its motion.

There is no corresponding universal formula by which potential energy can be expressed. The potential energy of a body is the work that body can do by virtue of the relative position of its parts. In each case we must determine how much work the body or system can do in passing from one relative position to another and then take this as the difference in potential energy of the body or system between these two positions.

The potential energy of a spring depends on the relative position of the parts of the spring. Work can be obtained by allowing the spring to return from its extended to its unextended length, during which time it exerts a force through a distance. If a mass is attached to the spring, the mass will be accelerated by this force and the potential energy will be converted to kinetic energy. In the gravitational case an object occupies a position with respect to the earth. The potential energy is actually a property of an object and the earth, considered as a system of bodies. It is the relative position of the parts of this system that determines its potential energy. The potential energy is greater when the parts are far apart than when they are close together. The loss of potential energy is equal to the work done in this process. This work is converted into kinetic energy of the bodies. In general, potential energy is not assigned to either body separately but is considered a joint property of the system.

EXAMPLE

What is the change in gravitational potential energy when a 1600-lb elevator moves from street level to the top of the Empire State Building, 1250 feet above street level?

Gravitational potential energy is

$$U = mgy$$

then

$$\Delta U = U_2 - U_1 = mg(Y_2 - Y_1)$$

but

$$mg = W = 1600 \text{ lb and} \\ Y_2 - Y_1 = 1250 \text{ ft}$$

so that

$$U = 1600 \times 1250 \text{ ft-lb} = \text{an increase of 2 million ft-lb}$$

Governing Laws

EXAMPLE

As an example of the simplicity and usefulness of the energy method of solving dynamic problems, consider the problem illustrated in the figure below. A block of mass m slides down a curved frictionless surface. The force exerted by the surface on the block is always normal to the surface and to the direction of the motion of the block, so that this force does no work. Only the gravitational forces do work on the block.

The mechanical energy is, therefore, conserved and we can write at once

$$mgy_1 + \frac{1}{2}mV_1^2 = mgy_2 + \frac{1}{2}mV_2^2$$

this gives

$$V_2^2 = V_1^2 + 2g(y_1 - y_2)$$

The speed at the bottom of the curved surface depends only on the initial speed and the change in vertical height but does not depend at all on the shape of the surface. In fact, if the block is initially at rest at $y_1 = h$, and if we set $y_2 = 0$, we obtain

$$V_2 = \sqrt{2gh}$$

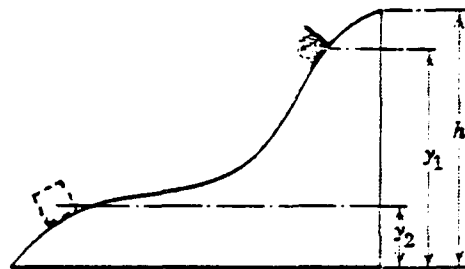

Now, back to our discussion of the energy equation. Consider a machine in which fluid flows in one end and out the other with only heat or work being added or removed between the entrance and exit. Such a machine is called a heat engine or a thermodynamic system.

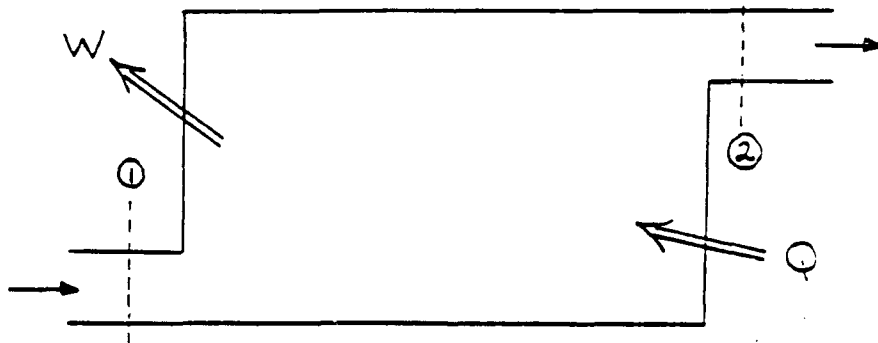

The Law of Conservation of Energy states that since energy cannot be created or destroyed, the energy level of the fluid leaving the system must be the same as the energy level of the fluid entering + the amount of heat added or removed between the entrance and exit + the amount of work added or removed between the entrance and exit. By common convention work or heat added to a system is positive (+), and that which is removed is negative (-). Stated analytically, this is:

$${}_1Q_2 - {}_1W_2 = E_2 - E_1 = {}_1\Delta E_2$$

where:

- ${}_1Q_2$ = heat added between 1 and 2
- ${}_1W_2$ = work removed between 1 and 2
- E_2 = energy level at 2
- E_1 = energy level at 1

Governing Laws

What then are the possible sources of energy which would change the energy level of the fluid flowing through the machine?

a.) Kinetic Energy – Between inlet and exit there may be a change in the velocity (V) of the fluid and hence a change in the kinetic energy,

$${}_1\Delta KE_2 = 1/2 m (V_2^2 - V_1^2)$$

where: ${}_1\Delta KE_2$ = change in kinetic energy between 1 and 2 (ft-lbs)

V_2 = velocity of fluid at exit (ft/sec)

V_1 = velocity of fluid at entrance (ft/sec)

m = mass of fluid (slugs).

b.) Potential Energy – If the fluid leaves the system at a different elevation than it entered, then there will be a change in its potential energy,

$${}_1\Delta PE_2 = w (Z_2 - Z_1)$$

where: ${}_1\Delta PE_2$ = change in potential energy between 1 and 2 (ft-#)

Z_2, Z_1 = elevations above a reference (ft)

w = weight of fluid (lbs)

c.) Internal Energy – The kinetic energy term concerned itself with only the difference between the average translational energies at the entrance and exit. In addition to translational velocities a molecule or particle of fluid also has random motion. As shown below, the translational velocity is the net effect of all the random motions of the particle in the direction of fluid motion.

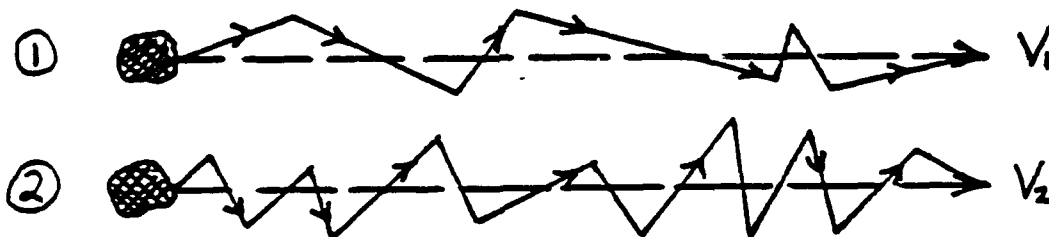

In the two cases shown above, the translational velocities V_1 and V_2 are the same but particle 2 has a much greater random motion. This random motion or random kinetic energy for liquids and gases has been found to be solely a function of the absolute temperature. The term itself is called **internal energy (u)**. Thus the change in this energy between entrance and exit is $w(u_2 - u_1)$ where the units of u are BTU/pound of fluid. Remember the specific heat at constant volume, C_v ? It is defined as $C_v = \Delta u / \Delta T$. If heat is added to a gas at a fixed volume, the added heat simply goes into increased internal energy.

d.) Two additional terms are usually included in the evaluation of $E_2 - E_1$.

(1) expansion work = $w \int P dv$. This is the work done in expanding or contracting a chunk of matter as it goes from the inlet to the exit of the system.

(2) flow work = $w \int v dP$. This is the work done in moving the chunk of matter physically from the entrance to the exit.

Governing Laws

Each of these terms depends on the particular process that the system undergoes. This process must be known before the terms can be evaluated. For incompressible fluids, $dv = 0$ and so the expansion work is zero.

Also,

$$\int_1^2 v dP = v(P_2 - P_1)$$

Combining all these terms into one massive equation gives:

$${}_1Q_2 - {}_1W_2 = w(u_2 - u_1) + w \int_1^2 P dv + w \int_1^2 v dP + \frac{w}{2g} (V_2^2 - V_1^2) + w(z_2 - z_1)$$

Units. Note that the internal energy term $w(u_2 - u_1)$ has units of BTU. ${}_1Q_2$, since it is a heat term, also has the units of BTU. All the other terms in the equation have units of ft-#. The conversion factor of $J = 778 \text{ ft-#/BTU}$ is used to bring each term to the same units. Also dividing through by w to make the units of each term BTU/# we have:

$${}_1Q_2 - {}_1W_2 = u_2 - u_1 + \int_1^2 \frac{P dv}{J} + \int_1^2 \frac{v dP}{J} + \left(\frac{V_2^2 - V_1^2}{2Jg} \right) + \frac{z_2 - z_1}{J}$$

This equation is called the **General Energy Equation** and is applicable to all flow processes in which heat and work are interchanged with a resultant change in the energy level.

Now, let us introduce a new term called **enthalpy (h)** which combines the internal energy, flow work, and expansion work terms,

$$h \equiv u + \frac{Pv}{J}$$

If this is our definition, then

$$\begin{aligned} \Delta h &= \Delta u + \Delta \left(\frac{Pv}{J} \right) \\ &= \Delta u + \frac{v \Delta P}{J} + \frac{P \Delta v}{J} \end{aligned}$$

or,

$$h_2 - h_1 = u_2 - u_1 + \int_1^2 \frac{v dP}{J} + \int_1^2 \frac{P dv}{J}$$

So, our general energy equation becomes

$${}_1Q_2 - {}_1W_2 = h_2 - h_1 + \frac{V_2^2 - V_1^2}{2Jg} + \frac{z_2 - z_1}{J}$$

Governing Laws

Remember specific heat at constant pressure, C_p ? It is defined as $C_p = \Delta h / \Delta T$. If a gas is to be held at constant pressure as it is heated, it must expand. As it expands, it does external work and hence any added heat must divide itself between the work done and the internal energy.

4.8 The Second Law of Thermodynamics

The essential content of the first law of thermodynamics is that energy is conserved. However, we can construct in our imaginations a great many thermodynamic processes which conserve energy but which actually never occur. For example, when a hot body and a cold body are put into contact, it simply does not happen that the hot body gets hotter and the cold body colder. Or again, a pond does not suddenly freeze on a hot summer day by liberating heat to its environment. And yet such processes do not violate the first law of thermodynamics. Similarly, the first law does not put any restriction on our ability to convert work into heat or heat into work, except that energy is conserved in the process. And yet in practice, although we can convert a given quantity of work completely into heat, we have never been able to devise a scheme that converts a given amount of heat energy completely into work. If we were able to convert a given amount of heat to work, just think of what would happen. We could use the heat of the oceans and the earth itself with no apparent cost. An enormous amount of power could be made available if we just cooled the ocean one degree.

On the basis of our experience to date, the reason that this complete conversion is not possible is that in every machine or process some of the heat is rejected and is therefore not available to do work. In fact, for most processes and machines, we have less than a 50% conversion.

From these types of empirical observations, a second law of thermodynamics has been formulated. The second law states that **it is impossible to construct an engine that will convert all the available heat to work.**

Let us first consider a system in thermodynamic equilibrium. A system will be in thermodynamic equilibrium when it meets the following requirements. (a) The system is in a state of mechanical equilibrium – there is no unbalanced force in the interior of the system and no unbalanced force between the system and its surroundings. (b) The system is in thermal equilibrium – all parts of the system are at the same temperature and this temperature is the same as that of the environment. (c) The system is in chemical equilibrium – it does not tend to undergo a spontaneous change of internal structure. A system in thermodynamic equilibrium can be specified macroscopically by giving the values of only a few quantities, such as pressure, volume, temperature, and quantity of a particular substance.

Now suppose that we change the state of the system. A change in state must involve some departure from thermodynamic equilibrium. For example, suppose that we change a system from one state to another having just half the volume. Imagine that we do this by quickly pushing down a piston. The system will not be in thermodynamic equilibrium; there will be relative motion of its parts owing to unbalanced forces, temperature differences may set in because the heating effects of the compression may affect different portions of the system in different ways, there may be chemical changes or changes in phase, such as condensation. Of course, eventually, if left to itself, the system may reach a new state of thermodynamic equilibrium. During the process of change, however, thermodynamic equilibrium does not exist.

Most processes of interest can be thought of as beginning in an equilibrium state, passing through nonequilibrium states, and ending in another equilibrium state. Thermodynamics seeks to understand such processes. But rather than concerning itself with the details of the highly complex

Governing Laws

Processes whereby nonequilibrium states approach equilibrium, thermodynamics seeks instead to obtain simple and general information about such processes by comparing their behavior to that of an ideal process, called a reversible process. In a reversible process we change the state of a system by continuous succession of equilibrium states.

For example, suppose we try to reduce the volume of a system to half its original value by a succession of small changes, we first increase the force on the piston by a very small amount. This will reduce the volume of the system a little; the system will depart from equilibrium, but only slightly. In a short time the system will reach a new equilibrium state. Then, we increase the force on the piston again by a very small amount, reducing the volume further. Again, we wait for a new equilibrium state to be established, and so forth. Hence, by many repetitions of this procedure we finally achieve the required change in volume. During this entire process the system is never in a state differing much from an equilibrium state. If we imagine carrying out this procedure with still smaller successive increases in pressure, the intermediate states will depart equilibrium even less. By indefinitely increasing the number of changes and correspondingly decreasing the size of each change, we arrive at an ideal process in which the system passes through a continuous succession of equilibrium states. In practice, we can approximate ideal reversible processes very closely by changing the conditions external to the system very slowly.

In an **isothermal process** the temperature of a system remains constant throughout the process. The temperature of a system as a whole has a definite value only in an equilibrium state, however, so that an isothermal process must involve only equilibrium states. Therefore, an isothermal process is a reversible process. In practice, the ideal isothermal process is approximated by changing the pressure and volume very slowly while keeping the system immersed in a bath at the required constant temperature.

In an **adiabatic process** no heat is allowed to enter or leave the system. Hence, an adiabatic process may be reversible or irreversible – the definition does not exclude either. In practice, we cannot obtain a perfect heat insulator. An adiabatic process would have to be carried out rapidly enough so that the system does not lose or gain a significant amount of heat. But a reversible process would have to be carried out slowly enough so that at each stage the system has enough time to come very near to equilibrium. A process that is both adiabatic and reversible is nevertheless achievable because the time required for equalization of pressure or for other processes to reach equilibrium is short compared to the rate at which heat is conducted. (A reversible, adiabatic process is often called an “**isentropic**” process. More on that later).

Governing Laws

The first heat engines constructed were found to be extremely inefficient devices. Only a small fraction of the heat absorbed at the high-temperature source could be converted to useful work. Even as engineering design improved, a sizable fraction of the absorbed heat was discharged at the lower-temperature exhaust of the engine, remaining unconverted to mechanical energy. It remained a hope to be able to devise an engine that could take heat from an abundant reservoir, like the ocean, and convert it completely into useful work. Then it would not be necessary to go to all the expense of providing a source of heat at a higher temperature than the outside environment by burning fuels. Likewise, we might hope to be able to devise a refrigerator that simply transfers heat from a cold body to a hot body, without requiring the expense

of outside work. Neither of these hopeful ambitions violate the first law of thermodynamics. In the case of the heat engine we would simply convert heat energy completely and directly into mechanical energy, the total energy being conserved in the process. In the case of the refrigerator, the heat energy would simply be transferred from cold body to hot body without any loss of energy in the process. Nevertheless neither of these ambitions has ever been achieved, and there is reason to believe they never will be. The impossibility of such devices is stated directly by the second law of thermodynamics.

There have been many different statements of the second law, each emphasizing another facet of the law, but all are logically equivalent to one another. For example, Rudolph Clausius stated it as follows: "It is impossible for any self-acting machine to convey heat continuously from one body to another at a higher temperature."

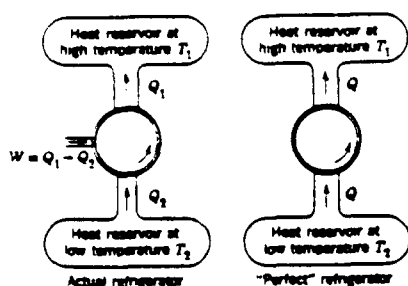

In an actual refrigerator, work W is needed to transfer heat from a low-temperature to a high-temperature reservoir. In a "perfect" refrigerator, heat would flow from the low-temperature to the high-temperature reservoir without any work being done on the engine. Notice that in both the "perfect" machines (here and above), energy is conserved, that is, the first law is fulfilled. Their inattainability is predicted instead by the second law of thermodynamics.

This statement rules out our ambitious refrigerator, for it implies that to convey heat continuously from a cold to a hot object it is necessary to supply work by an outside agent. We know from experience that when two bodies are in contact, heat energy flows from the hot body to the cold body. The second law rules out the possibility of heat energy flowing from cold to hot body in such a case and so determines the direction of transfer of heat. The direction can be reversed only by an expenditure of work. The second law is a broad generalization inferred from experience.

Lord Kelvin stated the second law as follows: "A transformation whose only final result is to transform into work heat extracted from a source which is at the same temperature throughout is impossible."

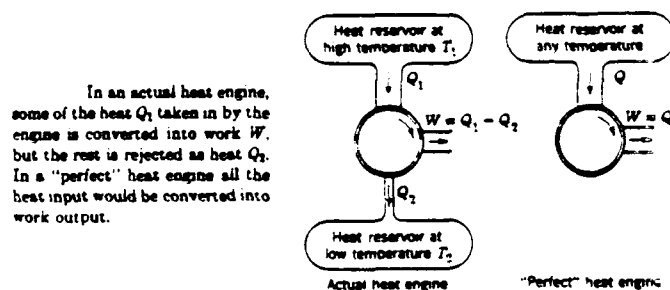

In an actual heat engine, some of the heat Q_1 taken in by the engine is converted into work W , but the rest is rejected as heat Q_2 . In a "perfect" heat engine all the heat input would be converted into work output.

Governing Laws

This statement rules out our ambitious heat engine, for it implies that we cannot produce mechanical work by extracting heat from a single reservoir without returning any heat to a reservoir at a lower temperature.

The second law shows us that many processes actually are irreversible. For example, Clausius' statement specifically rules out a simple reversal of the process of heat transfer from hot body to cold body. Not only will some processes not run backward by themselves but no combination of processes can undo the effect of an irreversible process without causing another corresponding change elsewhere.

The second law of thermodynamics is a broad generalization from experience. It has far-reaching implications in all areas of science because in principle all heat transfer problems – whether in astronomy, biology, chemistry, geology, or physics – can be reduced to that of conversion of heat energy to mechanical energy by means of a heat engine. While the first law imposes overall conservation of energy on a thermal process, the second law states that there are additional restrictions. The first law says “You can't win.” The second law says “You can't break even.” It would be nice to have some yardstick with which to measure either the available or the unavailable energy. Such a yardstick for unavailable energy has been defined and is called **entropy** (s). The entropy change can be shown to be – between states 1 and 2

$$S_2 - S_1 = C_p \ln \frac{T_2}{T_1} - \frac{R}{J} \ln \frac{P_2}{P_1}$$

or

$$S_2 - S_1 = C_v \ln \frac{T_2}{T_1} + \frac{R}{J} \ln \frac{v_2}{v_1}$$

For an **isentropic process** (one in which entropy does not change):

$$C_v \ln \frac{T_2}{T_1} + \frac{R}{J} \ln \frac{v_2}{v_1}$$

but, for an ideal gas

$$\frac{T_2}{T_1} = \frac{P_2 v_2}{P_1 v_1}$$

Therefore,

$$C_v \ln \left[\frac{P_2 v_2}{P_1 v_1} \right] = -\frac{R}{J} \ln \frac{v_2}{v_1}$$

$$C_v \left[\ln \frac{P_2}{P_1} + \ln \frac{v_2}{v_1} \right] = -\frac{R}{J} \ln \frac{v_2}{v_1} \quad \text{“A”}$$

This equation may be reduced by recalling

Governing Laws

$$C_p \equiv \frac{\Delta h}{\Delta T} = \frac{\Delta(u + Pv/J)}{\Delta T} = \frac{\Delta u}{\Delta T} + \frac{\Delta(RT)}{J\Delta T} = C_v + R/J$$

dividing both sides of the equation (recalling $\gamma = C_p/C_v$)

$$\begin{aligned} \frac{C_p}{C_v} &= \frac{C_v}{C_v} + \frac{R}{JC_v} \\ \gamma &= 1 + \frac{R}{C_v J} \\ C_v &= \frac{R}{J} (1/(\gamma - 1)) \end{aligned}$$

(again the "J" is incorporated to balance units).

We can combine this finding with equation "A" above to yield

$$\ln \left[\frac{P_2}{P_1} \left(\frac{v_2}{v_1} \right)^\gamma \right] = 0$$

or,

$$P_2 v_2^\gamma = P_1 v_1^\gamma = \text{constant}$$

This is the general expression for an isentropic process. By substitution of the perfect gas law ($Pv = RT$) into the above equation, the relationship between pressure and temperature, and temperature and specific volume can be found.

$$\left. \begin{aligned} \frac{P_2}{P_1} &= \left(\frac{T_2}{T_1} \right)^{\frac{\gamma}{\gamma-1}} \\ \frac{v_2}{v_1} &= \left(\frac{T_1}{T_2} \right)^{\frac{1}{\gamma-1}} \\ \frac{T_2}{T_1} &= \left(\frac{P_2}{P_1} \right)^{\frac{\gamma-1}{\gamma}} \end{aligned} \right| \text{ isentropic process}$$

On a P-v diagram an isentropic process is compared to others.

Governing Laws

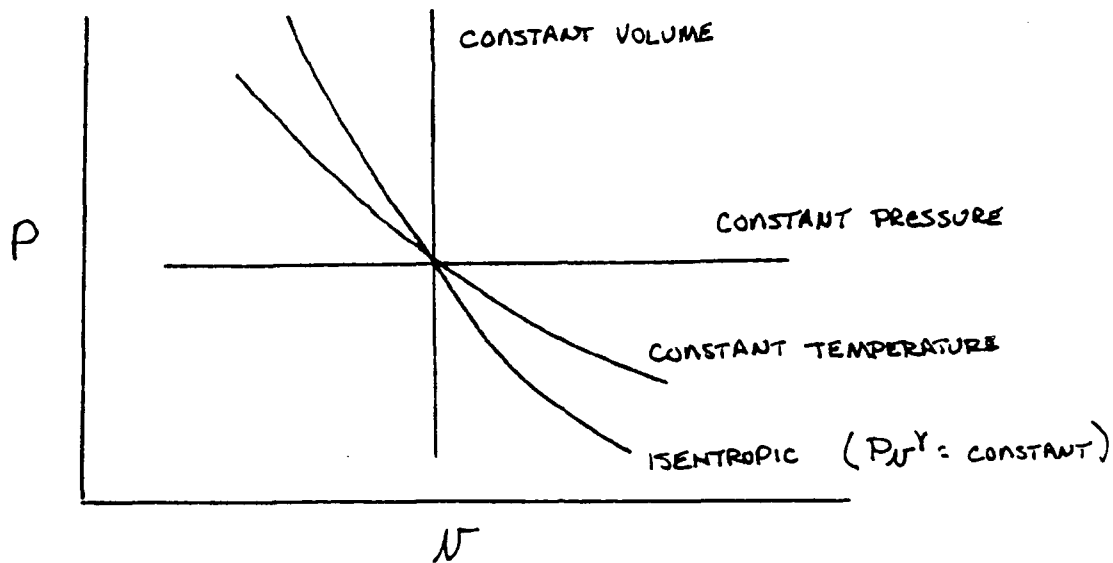

4.9 Bernoulli Revisited

At this point, we should point out that the General Energy Equation which we derived

$${}_1Q_2 - {}_1W_2 = h_2 - h_1 + \frac{V_2^2 - V_1^2}{2Jg} + \frac{Z_2 - Z_1}{J}$$

is in fact "general" in that it applies to systems with either incompressible fluids such as water or compressible fluids such as rocket exhaust gases or air.

That Bernoulli's Equation for incompressible fluids is a special case of the above equation can be shown as follows:

Recalling our definition of enthalpy, $h = U + Pv/J$, we have (with no heat transferred out or in, no work output, no elevation change) the energy equation for simple duct flow of a fluid,

$$U_2 - U_1 + \frac{P_2 v_2}{J} - \frac{P_1 v_1}{J} + \frac{V_2^2 - V_1^2}{2Jg} = 0$$

Now let's assume no change in Temperature (or U). In an incompressible fluid, $\rho_1 = \rho_2$ or $v_1 = v_2$, so

$$\frac{v}{J}(P_2 - P_1) + \frac{V_2^2 - V_1^2}{2Jg} = 0$$

and since $v = \frac{1}{\rho g}$

Governing Laws

$$P_2 - P_1 + \rho \left(\frac{V_2^2 - V_1^2}{2} \right) = 0$$

Bernoulli's Equation for Incompressible Flow.

Does the above equation look familiar? It should. It's Bernoulli's Equation. And as we've already seen, it is used to calculate flow properties when a liquid is involved as the working fluid. But what happens if the fluid is a gas? Gas density can be changed easily so the fluid must be considered "compressible". Is there a corresponding Bernoulli Equation for compressible flow?

Yes! Lets go back once again to our General Energy Equation, neglecting heat, work, and potential energy changes.

$$h_2 - h_1 + \frac{V_2^2 - V_1^2}{2Jg} = 0$$

For an ideal gas, $h = C_p T$
and $C_p = C_v + R/J$ as we have already seen.
So we can write

$$C_p T_2 - C_p T_1 + \frac{V_2^2 - V_1^2}{2Jg} = 0$$
$$\left(C_v + \frac{R}{J} \right) T_2 - \left(C_v + \frac{R}{J} \right) T_1 + \frac{V_2^2 - V_1^2}{2Jg} = 0$$

Now, also for an ideal gas $P = \rho g R T$.

$$\text{So, } C_v T_2 + \frac{P_2}{\rho_2 g J} - C_v T_1 - \frac{P_1}{\rho_1 g J} + \frac{V_2^2 - V_1^2}{2Jg} = 0$$

and since $C_v = \frac{R}{J} \left(\frac{1}{\gamma - 1} \right)$ for an ideal gas,

$$\frac{RT_2}{(\gamma - 1)J} + \frac{P_2}{\rho_2 g J} - \frac{RT_1}{(\gamma - 1)J} - \frac{P_1}{\rho_1 g J} + \frac{V_2^2 - V_1^2}{2Jg} = 0.$$

Combining terms, we get

$$\left(\frac{\gamma}{\gamma - 1} \right) \left(\frac{P_2}{\rho_2} - \frac{P_1}{\rho_1} \right) + \frac{V_2^2 - V_1^2}{2} = 0$$

Bernoulli's Equation for Compressible Flow.

CHAPTER V PROPULSION EQUATIONS

The theoretical thermodynamic relations of the processes inside a rocket chamber furnish the mathematical tools with which to calculate the performance and determine the design parameters of rockets. They are useful as a means for evaluating and comparing the performances of various rocket units with each other and they permit the prediction of the operational performance of any rocket unit and the determination of several necessary design parameters, such as nozzle size and shape, for any given performance requirement. This theory applies to chemical rocket engines (both liquid and solid propellant types), nuclear rocket engines, solar heating and arc heating rocket engines, or any rocket engine that uses the expansion of a gas as the propulsive mechanism for ejecting matter at high velocities.

5.1 Ideal Rocket

The analysis of an ideal rocket assumes one-dimensional flow. The usefulness of this concept is indicated by the fact that the measured performance is usually within ten percent of the calculated ideal values. In designing new rockets it has become accepted practice to use ideal rocket parameters which are then modified by appropriate corrections.

An ideal rocket is one in which the following assumptions are valid:

1. The working substance (propellant products) is homogeneous and invariant in composition throughout the rocket chamber and nozzle.
2. The working substance obeys the perfect gas laws.
3. There is no friction.
4. There is no heat transfer across the rocket walls; therefore, the flow is adiabatic.
5. The propellant flow is steady and constant. The expansion of the working fluid takes place in a uniform and steady manner without shock or discontinuities.
6. All the exhaust gases leaving the rocket nozzle have an axially directed velocity.
7. The gas velocity, pressure, and density is uniform across any section normal to the nozzle axis.
8. Chemical equilibrium is established within the rocket chamber and does not shift in the nozzle.
9. All the species of the working fluid are gaseous. Any condensed phases (liquid or solid) in the nozzle flow have negligible volume.

Because the chamber temperatures are high (4000 to 6000°F), the gases are well above their respective saturation condition and follow the perfect gas laws very closely. Postulating no friction and a steady flow without heat transfer to the wall allows the use of isentropic expansion relations in the rocket nozzle, thereby permitting the assumption of a maximum conversion of heat energy into the kinetic energy of the jet. This implies that the nozzle flow is thermodynamically reversible. The wall friction losses are difficult to determine accurately, but they are small.

Except for very small chambers the energy transferred as heat to the walls of the rocket unit is usually less than two percent of the total energy and, therefore, can be neglected.

Although fluctuations in the propellant flow rate of a steadily operating rocket chamber have been measured, their magnitude is so small that a steady state flow can be assumed.

Many nozzle configurations such as one having a double-cone converging-diverging contour or a bell-shaped diverging contour permit the gas to expand uniformly and without shock. The con-

Propulsion Equations

version of thermal energy into directed kinetic energy of the gases proceeds smoothly and without discontinuities; thus, the flow expansion losses are small. Certain other nozzle types, such as those having an annular configuration with a center body or some that induce flow separation, can (under certain flow conditions) have additional internal losses and sometimes some intentional shock waves. Their performance requires a more sophisticated theoretical treatment.

The nine assumptions above permit the derivation of a simple, one dimensional theory as explained in subsequent sections.

In this section, we will be using our understanding of the properties of matter and the basic laws of physics to derive the major equations for propulsion. To aid ourselves in this task, we will number our equations. In this way, referral to important relationships will be easier.

Summary of Thermodynamic Relations

The principle of conservation of energy may be written for an adiabatic flow process between any points x and y as the Energy Equation in which the decrease in enthalpy is equal to the increase in kinetic energy of the flowing gases,

$$h_x - h_y = \frac{V_y^2 - V_x^2}{2Jg} \quad (1)$$

$$C_p(T_x - T_y) = \frac{V_y^2 - V_x^2}{2Jg} \quad (2)$$

For ideal gases, the enthalpy is equal to the product of the specific heat and the absolute temperature. The principle of conservation of matter in steady flow process is expressed by equating the flow at any section x to the flow at section y , and is known in mathematical form as the Continuity Equation,

$$\dot{m}_x = \dot{m}_y = \rho_x A_x V_x = \rho_y A_y V_y \quad (3)$$

The ideal gas (perfect gas) law is

$$P_x V_x = mRT_x \quad (4)$$

The specific heat at constant pressure C_p , the specific heat at constant volume C_v , and their ratio γ are constant for perfect gases and are related.

$$\gamma = \frac{C_p}{C_v} \quad (5)$$

$$C_p = \frac{R}{J} \left(\frac{\gamma}{\gamma - 1} \right) \quad (6)$$

Propulsion Equations

For an isentropic flow process the following relations hold between any points x and y:

$$\frac{T_2}{T_1} = \left(\frac{P_2}{P_1} \right)^{\frac{\gamma-1}{\gamma}} = \left(\frac{v_2}{v_1} \right)^{\gamma-1} \quad (7)$$

For an isentropic expansion process the pressure will drop, the absolute temperature will drop by a substantially smaller factor, and the specific volume will increase. When the flow of a compressible fluid is stopped or stagnated isentropically, the prevailing conditions are known as the **total** or **stagnation conditions** and are designated by the subscript "o". The figure below shows the streamline flow about any immersed body such as a pressure or temperature probe. As the free-stream air arrives at the probe body, some is deflected around it and some (along the center streamline) flows up to the nose of the probe and stops. It is this flow that we want to evaluate.

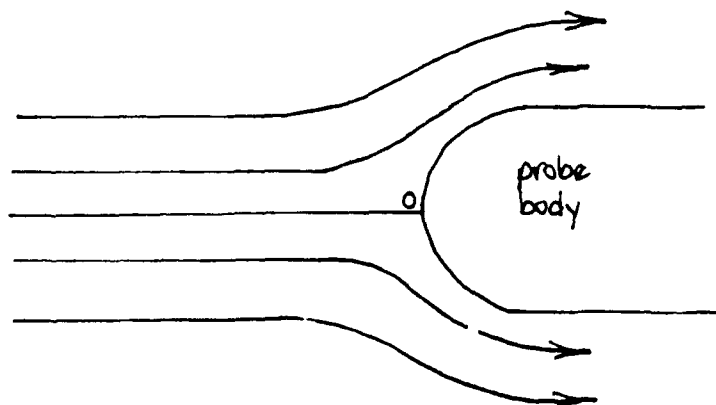

The General Energy Equation holds for flow along any streamline. Since the process is adiabatic ($Q = 0$), there is no shaft work ($W = 0$), and no change in potential energy along the streamline ($Z - Z_0 = 0$), the Energy Equation may be written,

$$h - h_o + \frac{V^2 - V_o^2}{2Jg} = 0 \quad (8)$$

re-arranging terms,

$$h + \frac{V^2}{2Jg} = h_o + \frac{V_o^2}{2Jg} = h_o \quad (\text{since } V_o = 0), \quad (9)$$

h_o is called the **total** or **stagnation enthalpy**. It is a constant at any point along the streamline.

Remembering that $h = C_p T$, equation 9 becomes

$$T_o = T + \frac{V^2}{2JgC_p} \quad (10)$$

Propulsion Equations

where T is fluid or free stream temperature and T_0 is the stagnation temperature. In an adiabatic flow process the stagnation temperature remains constant. The isentropic flow relation for stagnation conditions is

$$\frac{T_0}{T} = \left(\frac{P_0}{P}\right)^{\frac{\gamma-1}{\gamma}} = \left(\frac{v}{v_0}\right)^{\gamma-1} \quad (11)$$

We have seen already that the velocity of sound, a , in ideal gases is independent of pressure. It is defined as

$$a = \sqrt{\gamma g R T} \quad (12)$$

The Mach number is a dimensionless flow parameter and is defined as the ratio of the flow velocity to the local acoustic (sound) velocity

$$M = \frac{V}{a} = \frac{V}{\sqrt{\gamma g R T}} \quad (13)$$

The Mach number is less than 1.0 when the flow is subsonic, greater than 1.0 when the flow is supersonic, and equal to 1.0 when the flow velocity is equal to the velocity of sound. The relationship between total temperature and Mach number can be derived as follows:

From equation 10

$$\begin{aligned} T_0 &= T + \frac{V^2}{2J C_p g} = T \left(1 + \frac{V^2}{2J g C_p T} \right) \\ &= T \left[1 + \frac{V^2}{2J g T \left(\frac{R}{J} \right) \left(\frac{\gamma}{\gamma-1} \right)} \right] && \text{from eq. 6} \\ &= T \left(1 + \frac{\gamma-1}{2} \frac{V^2}{a^2} \right) && \text{from eq. 12} \\ &= T \left(1 + \frac{\gamma-1}{2} M^2 \right) \end{aligned} \quad (14)$$

or

$$M = \sqrt{\frac{2}{\gamma-1} \left(\frac{T_0}{T} - 1 \right)} \quad (15)$$

Propulsion Equations

Just as total enthalpy is a measure of the total energy in the flow, so is total (or stagnation) temperature. It is seen from equation 14 to be a function of the freestream Mach number. A temperature probe placed at point "o" in the above figure will read the total temperature rather than the static temperature. Static temperature is that which would be measured by a probe moving with the fluid. The difference between the two readings is due to the kinetic energy of the freestream. The same is true of pressure. Since the process of decelerating the flow along the streamline to point "o" is essentially a frictionless and adiabatic (isentropic) process, we already have a relation between pressure and temperature

$$\frac{P_o}{P} = \left(\frac{T_o}{T} \right)^{\frac{\gamma}{\gamma-1}} \quad (16)$$

Therefore,

$$\frac{P_o}{P} = \left(1 + \frac{\gamma-1}{2} M^2 \right)^{\frac{\gamma}{\gamma-1}} \quad (17)$$

and for density,

$$\frac{\rho_o}{\rho} = \left(\frac{T_o}{T} \right)^{\frac{1}{\gamma-1}} \quad (18)$$

so,

$$\frac{\rho_o}{\rho} = \left(1 + \frac{\gamma-1}{2} M^2 \right)^{\frac{1}{\gamma-1}} \quad (19)$$

The area ratio for an isentropic nozzle can be expressed in terms of Mach numbers for any points x and y with the nozzle. The relation is derived below.

Conservation of mass (eq. 3) requires

$$\rho_x A_x V_x = \rho_y A_y V_y$$

or

$$\frac{A_x}{A_y} = \frac{\rho_y V_y}{\rho_x V_x}$$

But, in isentropic flow ($\rho_o = \text{constant}$), we can employ equation 19 to produce

$$\frac{A_x}{A_y} = \frac{\left(1 + \frac{\gamma-1}{2} M_y^2 \right)^{\frac{1}{\gamma-1}} \frac{a_y V_y}{a_x V_x}}{\left(1 + \frac{\gamma-1}{2} M_x^2 \right)^{\frac{1}{\gamma-1}}}$$

Propulsion Equations

with the definition of acoustic speed (eq. 12) and Mach' number (eq. 13) we can re-write the equation to read

$$\frac{A_x}{A_y} = \frac{\left(1 + \frac{\gamma-1}{2} M_y^2\right)^{\frac{1}{\gamma-1}}}{\left(1 + \frac{\gamma-1}{2} M_x^2\right)^{\frac{1}{\gamma-1}}} \sqrt{\frac{T_y}{T_x} \frac{M_y}{M_x}}$$

Which, combined with equation 14 and grouping terms, gives

$$\frac{A_x}{A_y} = \frac{M_y}{M_x} \sqrt{\frac{\left(1 + \frac{\gamma-1}{2} M_x^2\right)^{\frac{\gamma+1}{\gamma-1}}}{1 + \frac{\gamma-1}{2} M_y^2}}$$

This relation is plotted below for $A_y = A_t$ and $M_y = 1.0$.

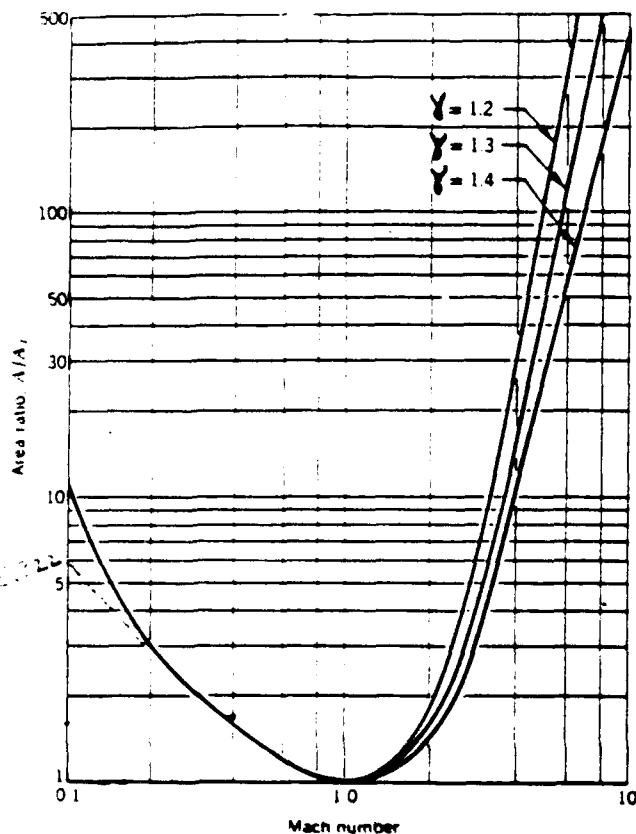

Relation of area ratio to Mach number for isentropic flow in a De Laval nozzle.

EXAMPLE – An ideal rocket chamber is to operate at sea level using propellants whose combustion products have a specific heat ratio of 1.30. Determine the required chamber pressure and nozzle area ratio between throat and exit if the nozzle exit Mach number is 2.40. The nozzle inlet Mach number may be considered to be zero.

SOLUTION – For optimum expansion (as we shall later see) the exit pressure should be equal to the atmospheric pressure of 14.7 psia. If the chamber velocity is small, the chamber pressure is equal to the total pressure and is from equation 17

$$\begin{aligned} P_o &= P \left(1 + \frac{\gamma-1}{2} M^2\right)^{\frac{\gamma}{\gamma-1}} \\ &= 14.7 \left(1 + 0.15(2.4)^2\right)^{\frac{1.3}{0.3}} \\ &= 132 \text{ psi.} \end{aligned}$$

The area ratio is determined from equation 20 with $M = 1.0$ at the throat

$$\begin{aligned} \epsilon &= \frac{A_2}{A_t} = \frac{1.0}{2.4} \sqrt{\frac{\left(1 + 0.15(2.4)^2\right)^{\frac{2.3}{0.3}}}{1 + 0.15}} \\ &= 2.64 \end{aligned}$$

Propulsion Equations

Isentropic Flow Through Nozzles

A nozzle is a section of duct whose sole purpose is to increase the velocity of the fluid by converting internal energy, flow energy, and/or expansion energy to kinetic energy. In an ideal nozzle, there is no shaft work ($W=0$) and no heat transfer ($Q=0$). There is also no change in potential energy (elevation) for the nozzles with which we will be concerned. Therefore, equation 1 becomes

$$h_2 - h_1 + \frac{V_2^2 - V_1^2}{2Jg} = 0$$

where subscripts 1 and 2 refer to the inlet and exit of the nozzle.

Rearranging terms and recalling the definition of total enthalpy

$$h_2 + \frac{V_2^2}{2Jg} = h_1 + \frac{V_1^2}{2Jg}$$

$$C_p T_2 + \frac{V_2^2}{2Jg} = h_{o1} + \frac{V_1^2}{2Jg}$$

$$C_p T_2 + \frac{V_2^2}{2Jg} = C_p T_{o1} + \frac{V_1^2}{2Jg}$$

In a nozzle, we are primarily interested in the magnitude of the exit velocity, V_2 , so solving for this quantity, we get

$$V_2 = \sqrt{2Jg \left[C_p(T_{o1} - T_2) + \frac{V_1^2}{2Jg} \right]}$$

recalling $C_p = \frac{R}{J} \left(\frac{\gamma}{\gamma - 1} \right)$ and rearranging,

$$V_2 = \sqrt{\frac{2g\gamma}{\gamma - 1} RT_{o1} \left(1 - \frac{T_2}{T_{o1}} \right) + V_1^2}$$

and since the process is isentropic, we can use the relationship in equation 7 to express nozzle exit velocity in terms of pressure

$$V_2 = \sqrt{\frac{2g\gamma}{\gamma - 1} RT_{o1} \left[1 - \left(\frac{P_2}{P_{o1}} \right)^{\frac{\gamma-1}{\gamma}} \right] + V_1^2}$$

Propulsion Equations

This equation also holds for any two points within the nozzle. When the chamber cross section is large compared to the nozzle section, the chamber velocity is comparatively small, and the term V_1^2 can be neglected. The chamber temperature T_{01} is equal to the nozzle inlet temperature; for an isentropic nozzle flow process it is also equal to the stagnation temperature.

The maximum value of the nozzle exit velocity is reached at an infinite pressure ratio P_{01}/P_2 . This maximum value equals

$$V_{2\text{MAX}} = \sqrt{\frac{2gy}{\gamma - 1} RT_{01}}$$

It is interesting to note that the exhaust velocity has a finite value at infinite pressure ratios, such as when we exhaust into a vacuum. In the expansion, the gas temperature falls below the liquification or freezing point. Then the working fluid no longer behaves as a gas, and this maximum value actually can never be achieved.

EXAMPLE. A rocket operates at sea level ($P_2 = 14.7$ psia) with a chamber pressure of $P_1 = 300$ psia (43200 lb/ft²), a chamber temperature of $T_1 = 4000^\circ\text{R}$, and a propellant consumption of $\dot{w} = 2.2$ lb/sec. (Let $\gamma = 1.30$, $C_p = 0.359$ Btu/lb $^\circ\text{R}$, and $R = 64.4$) Show graphically the variation of A , v , V , and M , with respect to pressure in the nozzle.

SOLUTION. Select a series of pressure values and calculate for each pressure the corresponding values of v , V , and A . A sample calculation is given below. The initial specific volume v_1 is calculated from the equation of state of a perfect gas, equation 4

$$v_1 = \frac{RT_1}{P_1} = \frac{64.4(4000)}{43200} = 5.96 \text{ ft}^3/\text{lb}$$

In an isentropic flow at a point of intermediate pressure, say at $P_x = 200$ psi, the specific volume is, from equation 7

$$v_x = v_1 \left(\frac{P_1}{P_x} \right)^{\frac{1}{\gamma}} = 5.96 \left(\frac{300}{200} \right)^{\frac{1}{1.3}} = 8.14 \text{ ft}^3/\text{lb}$$

and the temperature is

$$T_x = T_1 \left(\frac{P_x}{P_1} \right)^{\frac{\gamma-1}{\gamma}} = 4000 \left(\frac{200}{300} \right)^{\frac{0.3}{1.3}} = 3640^\circ\text{R}$$

which permits the calculation of the velocity from equation 21 ($V_1 = 0$)

$$V_x = \sqrt{\frac{2(32.2)(1.30)}{0.3} (64.4)(4000)(0.9)} = 2540 \text{ ft/sec}$$

Propulsion Equations

The cross-sectional area is found from equation 3

$$A_x = \frac{\dot{w}_x v_x}{V_x} = \frac{(2.2)(8.14)}{2540} = 0.00704 \text{ ft}^2$$

The Mach number M is from equation 13

$$M_x = \frac{V_x}{\sqrt{\gamma g R T_x}} = 0.81$$

The figure below shows a plot of the variation of the velocity, the specific volume, the area, the Mach number, and the pressure in this nozzle; Table 1 shows the calculated results.

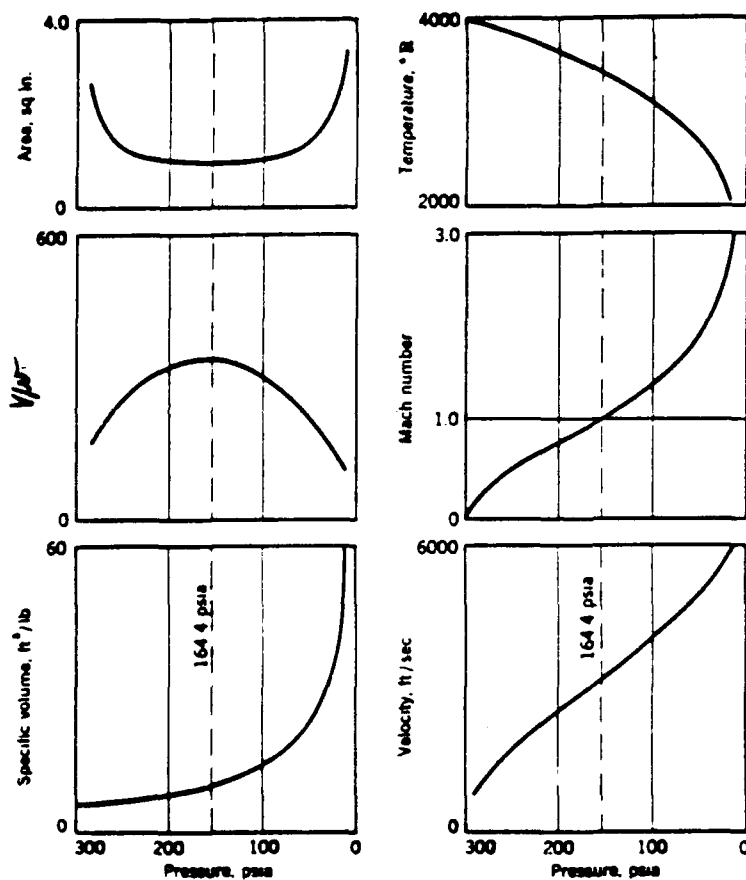

TABLE 1. TABULATION OF NOZZLE DATA FOR THE EXAMPLE

P_x	T_x	v_x	V_x	A_x	V/\sqrt{r}	M_x
300	4000	5.96	0		0	0
250	3790	6.90	1730	1.26	250	0.53
200	3640	8.14	2540	1.02	310	0.80
164	3480	9.48	3050	0.98	322	1.00
100	3100	13.9	4010	1.10	288	1.42
60	2750	20.6	4720	1.37	231	1.79
14.7	1990	60.8	6000	3.12	99	2.59

Propulsion Equations

A number of interesting deductions can be made from this example. Very high gas velocities (over a mile per second) can be obtained in rocket nozzles. The temperature drop of the combustion gases through a rocket nozzle is appreciable. In the example given, the temperature changed through 2010°F in a relatively short distance. This is not surprising, for the increase in the kinetic energy of the gases is derived from a decrease of the enthalpy, which in turn is roughly proportional to the decrease in temperature. Because the exhaust gases are still very hot (1900°R) when leaving the nozzle, they contain considerable energy not available for conversion into kinetic energy of the jet.

The required nozzle area decreases to a minimum (at 164 psi pressure) and then increases again. Nozzles of this type (often called De Laval nozzles after their inventor) consist of a **convergent** and a **divergent** section. From the Continuity Equation the area is inversely proportional to the ratio V/v . This quantity is also plotted. There is a maximum in the curve V/v because at first the velocity increases at a greater rate than the specific volume; however, in the divergent section, the specific volume increases at a greater rate.

The minimum nozzle area is called the **throat area**. The ratio of the nozzle exit area A_e to the throat A_t is called the nozzle area **expansion ratio** and is designated by the Greek letter ϵ .

$$\epsilon = A_e/A_t$$

For any isentropic steady flow process, such as occurs in rocket nozzles, the weight flow can be computed from the Continuity Equation, the isentropic relations, and the nozzle gas velocity between any section x and the first nozzle inlet section.

$$\frac{\dot{m}}{A_x} = P_{01} \sqrt{\frac{2\gamma}{\gamma - 1} \frac{1}{gRT_{01}} \left(\frac{P_x}{P_{01}}\right)^{\frac{2\gamma}{\gamma - 1}} \left[1 - \left(\frac{P_x}{P_{01}}\right)^{\frac{\gamma - 1}{\gamma}}\right]} \quad (23)$$

This equation is often referred to as De Saint Venant's Equation. It relates the mass flow per unit area to the chamber conditions and the pressure ratio P/P_{01} . The figure on the next page shows the dimensionless mass flow per unit area as a function of the pressure ratio. In general, the pressure ratio will have a value somewhere between zero and unity. It is easily seen from equation 23 that for a pressure ratio equal to one, the mass flow per unit area is zero. This is clear, because if there is no pressure difference between the chamber and a point downstream, there cannot be a steady flow and thus $\dot{m} = 0$. The second zero of equation 23 occurs for $P/P_{01} = 0$.

In this case, we have expanded to vacuum. As the mass flow itself is a constant for steady flow, this means that the exit area has to be infinitely large. On the sonic surface, where area attains its minimum value, we find the maximum mass flow per unit area.

Propulsion Equations

The dimensionless mass flow per unit area versus the pressure ratio for a converging-diverging nozzle.

The maximum gas flow per unit area occurs at the throat, and a unique gas pressure corresponding to this maximum flow exists. This throat pressure P_t for a maximum flow in an isentropic expansion nozzle can be found by differentiating equation 23 and setting the derivative equal to zero.

$$\frac{P_t}{P_{01}} = \left(\frac{2}{\gamma + 1} \right)^{\frac{\gamma}{\gamma - 1}} \quad (24)$$

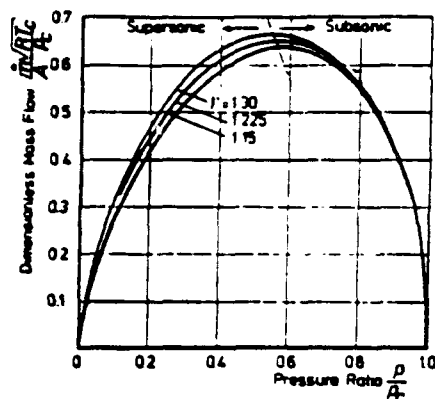

The throat pressure for which the isentropic weight flow is a maximum is called the **critical pressure**. The flow through a given rocket nozzle with given inlet condition is less than maximum possible if the pressure ratio is larger than that defined by equation 24. Rocket thrust chambers usually have sufficient chamber pressure to attain the critical pressure at the throat.

At the point of critical pressure, the values of specific volume and the temperature can be obtained from the isentropic relations and equation 7.

$$v_t = v_{01} \left(\frac{\gamma + 1}{2} \right)^{\frac{1}{\gamma - 1}} \quad (25)$$

$$T_t = T_{01} \left(\frac{2}{\gamma + 1} \right) \quad (26)$$

From equations 21, 24, and 26, the critical velocity or throat velocity V_t is obtained.

$$\begin{aligned} V_t &= \sqrt{\frac{2g\gamma}{\gamma + 1} RT_{01}} \\ &= \sqrt{\gamma g RT_t} \end{aligned} \quad (27)$$

The first version of this equation permits the velocity to be calculated directly from the nozzle inlet conditions without any of the throat conditions being known. The critical throat velocity V_t is always equal to the local acoustic velocity, a , for ideal nozzles in which critical conditions prevail; the Mach number at the throat of an ideal rocket is unity. The divergent portion of a nozzle permits a further decrease in pressure and an increase in velocity above the velocity of sound. If the nozzle is cut off at the throat section, the exit gas velocity will be sonic. The sonic and supersonic flow condition can be attained only if the critical pressure prevails at the throat, that is if P/P_{01} is equal to or less than the quantity defined by equation 24. There are, therefore, essentially three types of nozzles: subsonic, sonic, and supersonic.

Propulsion Equations

The supersonic nozzle is the one which is of interest to the rocket engineer. The ratio between the inlet and exit pressures in all rockets is sufficiently large to induce supersonic flow. Only if the chamber pressure drops below approximately 32 lb per square inch absolute is there any danger of not producing supersonic flow in the divergent portion of the nozzle.

The velocity of sound is equal to the velocity of propagation of a pressure wave within the medium, sound being essentially a type of pressure wave. If, therefore, sonic velocity is reached at any one point within a steady flow system, it will be impossible for a pressure disturbance to travel upstream past the location of sonic or supersonic velocity. Therefore, any partial obstruction or disturbance of the flow downstream of the nozzle throat section will have no influence on the flow at the throat section or upstream of the throat section, provided that this disturbance does not raise the downstream pressure above its critical value. It will not be possible to increase the throat velocity or the flow rate in the nozzle by lowering the exit pressure or evacuating the exhaust section. The flow rate through the throat is derived from equations 23, 24, to be

$$\dot{m} = A_t P_{01} \sqrt{\frac{\gamma}{gRT_{01}} \left(\frac{2}{\gamma+1}\right)^{\frac{\gamma+1}{\gamma-1}}} \quad (28)$$

The weight flow through a rocket nozzle is, therefore, proportional to the throat area A_t , the upstream pressure P_{01} , inversely proportional to the square root of the absolute nozzle inlet temperature T_{01} , and a function of the gas properties. For a supersonic nozzle the ratio between the throat area and any downstream area at which the pressure P_x prevails can be expressed as a function of the pressure ratio and the specific heat ratio as follows, by using equations 4, 21, 25, and 27.

$$\begin{aligned} \frac{A_t}{A_x} &= \frac{v_t V_x}{v_x V_t} \\ &= \left(\frac{\gamma+1}{2}\right)^{\frac{1}{\gamma-1}} \left(\frac{P_x}{P_{01}}\right)^{\frac{1}{\gamma}} \sqrt{\frac{\gamma+1}{\gamma-1} \left[1 - \left(\frac{P_x}{P_{01}}\right)^{\frac{\gamma-1}{\gamma}}\right]} \end{aligned} \quad (29)$$

This is a direct relationship between the local pressure P/P_c , and the expansion ratio A/A_t . The figure below gives the pressure ratio as a function of the expansion ratio and γ , for the supersonic part of the nozzle.

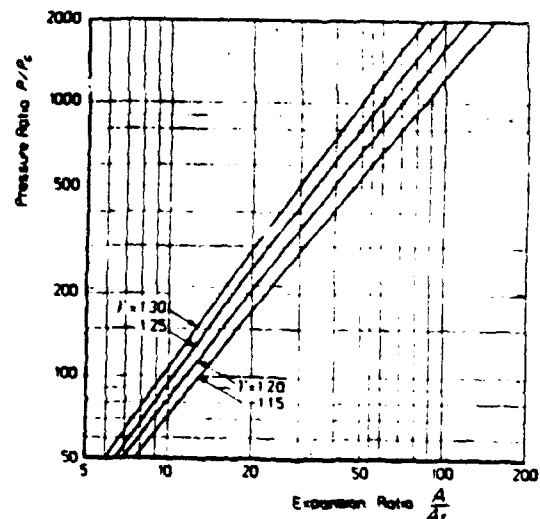
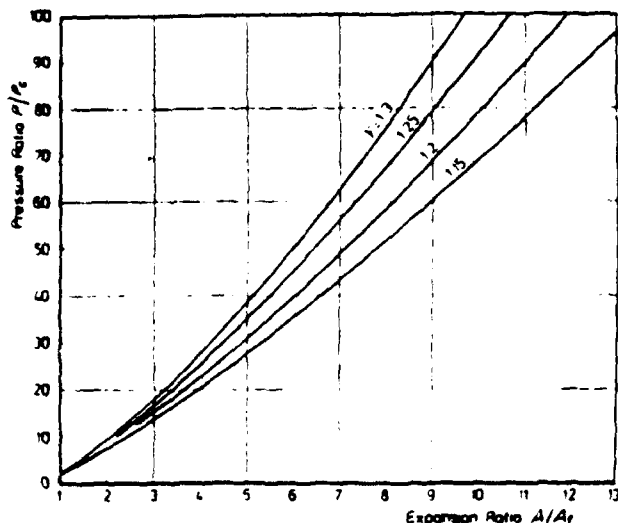

Propulsion Equations

Equation 29 allows the direct calculation of the expansion ratio, A_e/A_t , for given pressure ratio, P_e/P_c . However, for a given expansion ratio, iterative methods have to be used to find the pressure ratio. One should always be aware that there are two real solutions of equation 29 for a given expansion ratio: the subsonic and the supersonic solution.

The relation between exit pressure and exit surface is found by setting $A_x = A_e$ and $P_x = P_e$ in equation 29.

$$\frac{A_e}{A_t} = \frac{\left(\frac{2}{\gamma+1}\right)^{\frac{\gamma+1}{2(\gamma-1)}}}{\sqrt{\frac{2\gamma}{\gamma-1} \left(\frac{P_e}{P_c}\right)^{\frac{2}{\gamma}} \left[1 - \left(\frac{P_e}{P_c}\right)^{\frac{\gamma-1}{\gamma}}\right]}} \quad (30)$$

With the theory as developed in this section, we can compute the flow properties as functions of location in the nozzle. In general, the Mach number and velocity will increase with the distance travelled downstream, while pressure, temperature, density and the local speed of sound will decrease.

5.2 Thrust Equation

Velocities. Pressures. Mass flow rates. How do they all fit together? Do they all fit together?

Yes, there is a method to this apparent madness. With the foundation we have just laid, we can now build an understanding of the design and evaluation of solid rocket motors. The major portion of our remaining work will focus on what is called internal ballistics. Internal ballistics can be defined as:

the application of the governing physical laws and empirical relations to describe rocket motor behavior. . . . bringing together the subjects of gas dynamics, thermodynamics, solid propellant combustion, and grain regression to predict motor pressure and thrust.

Notice that our definition refers to both physical laws and experimentally determined relations. Internal ballistics is far from an exact science. Fortunately, the unknowns are usually of less importance compared to the major, predictable characteristics. Prediction of rocket motor performance can thus be thought of as an accurate, efficient process with known deficiencies. Time and human effort may or may not remove the deficiencies at some future date.

We will deal with the "knowns" – those relationships which through theoretical development or experimental discovery have been shown to play a role in the performance of a solid rocket motor. It is worthwhile to begin with discussions and derivations of basic parameters and equations.

The temptation exists to compare complex engines such as turbojets or automotive engines with simple solid rocket motors and to dismiss the latter as a trivial design problem. True, the solid rocket motor is "simple", deceptively so. Within the confines of this simple pressure vessel, one of the most severe operating environments known to man exists: internal pressures reaching 3000 psi; gas temperatures as hot as 6500° F. This is certainly not an easy environment to design within – indeed, it poses special problems to the engineer which necessitate simplicity in design.

Propulsion Equations

A typical rocket motor is shown in the figure below. All solid rockets contain four basic components: (1) A quantity of energetic material (propellant) which is specially configured. This propellant charge is called the **grain**. Its configuration design will be discussed later. (2) A pressure vessel called the **chamber** or **case** which contains the high pressures which result from the burning of the propellant grain. The case may be composed of a metal such as steel or aluminum or of composites such as glass fiber and epoxy resin. (3) A **nozzle** to focus and accelerate the combustion gas. (4) An electrically initiated device called the **igniter** which starts the propellant burning.

A component usually present, but not always, is a layer of insulating material along the inner surface of the chamber. The temperatures within a solid rocket motor are far in excess of what typical metals can withstand, so the desirability of an insulation layer is obvious.

Also, from the figure below we realize that the lack of a throttle or other controlling device is a feature of solid rocket motors. Once ignited, the propellant grain burns until it is consumed. Any throttling of thrust is pre-programmed into the design and is thus unchangeable.

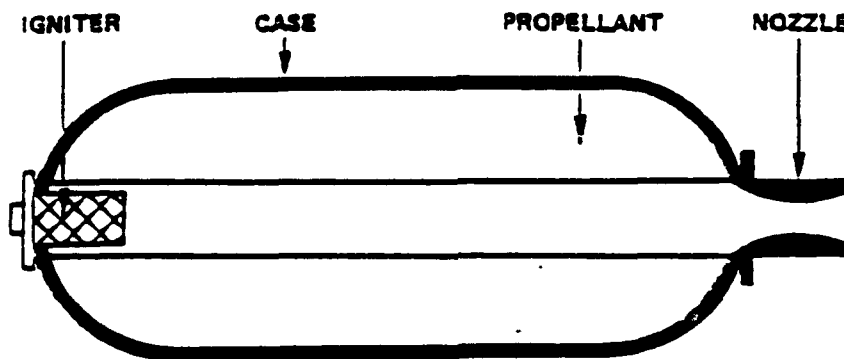

Consider the rocket motor shown below

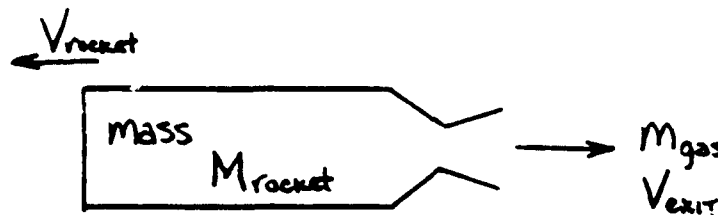

The rocket motor of mass M_R and velocity V_R is ejecting gas at a rate M with a velocity V_e with respect to the rocket. Conservation of momentum requires that

Δ momentum of rocket = Δ momentum of the ejected gas

$$\Delta(M_R V_R) = -\Delta M_{\text{gas}} (V_R - V_{\text{exit}})$$

$$M_R \Delta V_R + V_R \Delta M_R = V_{\text{exit}} \Delta M_{\text{gas}} - V_R \Delta M_{\text{gas}}$$

but, any decrease in rocket mass equals the corresponding increase in mass of gas ejected

Propulsion Equations

So,

$$\Delta M_R = -\Delta M_{\text{gas}}$$

$$M_R \Delta V_R + V_R \Delta M_R = V_{\text{exit}} \Delta M_{\text{gas}} + V_R \Delta M_R$$

and

$$\Delta M_{\text{gas}} = \dot{M}_{\text{gas}} \Delta t$$

So,

$$M_R \Delta V_R = \dot{M}_{\text{gas}} \Delta t V_{\text{exit}}$$

or,

$$M_R \frac{\Delta V_R}{\Delta t} = \dot{M}_{\text{gas}} V_{\text{exit}}$$

but,

$$\frac{\Delta V_R}{\Delta t} = a \quad (\text{acceleration})$$

and according to Newton

$$F = \dot{M}_{\text{gas}} V_{\text{exit}}$$

We now have an equation defining the thrust on a rocket motor due to the gases being expelled. In addition to this momentum thrust, atmospheric forces act on the rocket motor as shown

The atmospheric force is

$$F = (P_e - P_a) A_e$$

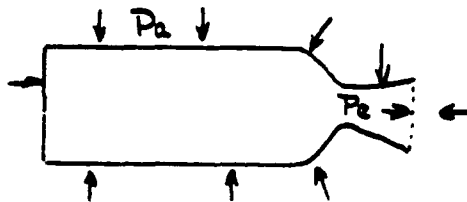

and the net force on the motor is the sum of the momentum thrust and the atmospheric force

$$F = V_e \dot{m} + (P_e - P_a) A_e$$

Propulsion Equations

Where

- V_e = nozzle exit velocity of the gases (ft/sec).
- \dot{m} = mass flow rate of gas ejected, (slugs/sec).
- P_e = gas pressure of the exhaust gases at the nozzle exit (psia).
- P_a = atmospheric pressure (psia).
- A_e = nozzle exit area (in²).

Equation 31 is known as the **Thrust Equation**. It shows that the thrust of a rocket motor is independent of flight velocity. It also shows that the presence of the atmosphere reduces the thrust available from a rocket motor and that the motor operates most efficiently in a vacuum.

Neither instantaneous mass flow rate nor exit velocity are easily measured parameters. If the Thrust Equation is to be used to predict motor performance, it must be modified and expanded to employ more readily available parameters. Fortunately, we have already derived equations for both nozzle exit velocity (eq. 21), and mass flow rate (eq. 28), so we can easily combine equations 21, 28, and 31 to give

$$\frac{F}{P_c A_t} = \sqrt{\left(\frac{2\gamma^2}{\gamma-1}\right)\left(\frac{2}{\gamma+1}\right)^{\frac{\gamma+1}{\gamma-1}} \left[1 - \left(\frac{P_e}{P_c}\right)^{\frac{\gamma-1}{\gamma}}\right]} + \left(\frac{P_e}{P_c} - \frac{P_{atm}}{P_c}\right) \frac{A_e}{A_t} \quad (32)$$

Where

- P_c = chamber pressure.
- P_e = nozzle exit pressure.
- A_t = nozzle throat area.
- A_e = nozzle exit area.
- γ = ratio of specific heats.

Equation 32 is more formidable looking than equation 31. It is, however, a more useable expression for the Thrust Equation. The right hand side of equation 32 is called the **thrust coefficient**, and is seen to be a function of the nozzle configuration A_e/A_t and the pressure drop through the nozzle P_e/P_c . Recall from our discussion back at equation 30 that A_e/A_t and P_e/P_c are related. Given P_e/P_c , you can solve for A_e/A_t directly. Given A_e/A_t (which is what we are usually given), an iterative procedure must be used to solve for P_e/P_c . The thrust coefficient designated C_F , is often seen graphically in charts such as those which follow.

On the next page, the thrust coefficient is plotted as a function of the pressure ratio and the area ratio for $\gamma = 1.30$ and 1.20 . These two sets of curves are useful in solving various nozzle problems, for they permit an evaluation of under- and over-expansion as explained in the following paragraphs. The values given in these figures are theoretical and do not consider any losses such as friction or internal shockwaves.

As the figures indicate, for any given ratio of chamber-to-atmospheric pressure, there exists an optimum nozzle design (ratio of exit-to-throat area). This occurs when the exit pressure equals the atmospheric pressure. Charts such as these guide the designer in the proper selection of chamber pressure/nozzle configuration combinations.

If we rearrange equation 32 and employ the symbol C_F for thrust coefficient, we arrive at our third form of the Thrust Equation

Propulsion Equations

$$F = C_F P_c A_t \quad (33)$$

If we ignore the interrelationships between the parameters, we see that thrust is directly proportional to chamber pressure and to nozzle throat area. This is an important fact and will come up again in discussions on motor design. Because the thrust coefficient is a function of chamber pressure, the thrust is not quite proportional to P_c . However, it is directly proportional to the throat area. The thrust coefficient determines the amplification of thrust due to the gas expansion in the rocket nozzle as compared to the thrust that would be exerted if the chamber pressure acted over the throat area only.

Clearly, if we know motor chamber pressure, P_c , we can now (knowing our nozzle configuration) calculate the thrust of our rocket motor. And, if the pressure within our motor varies with time, we can determine the corresponding thrust history. So, the question now before us is, "How can we determine the pressure at which a rocket motor will operate?" Before we can answer this question, we must first be introduced to a few definitions and to the concept of propellant combustion.

Propulsion Equations

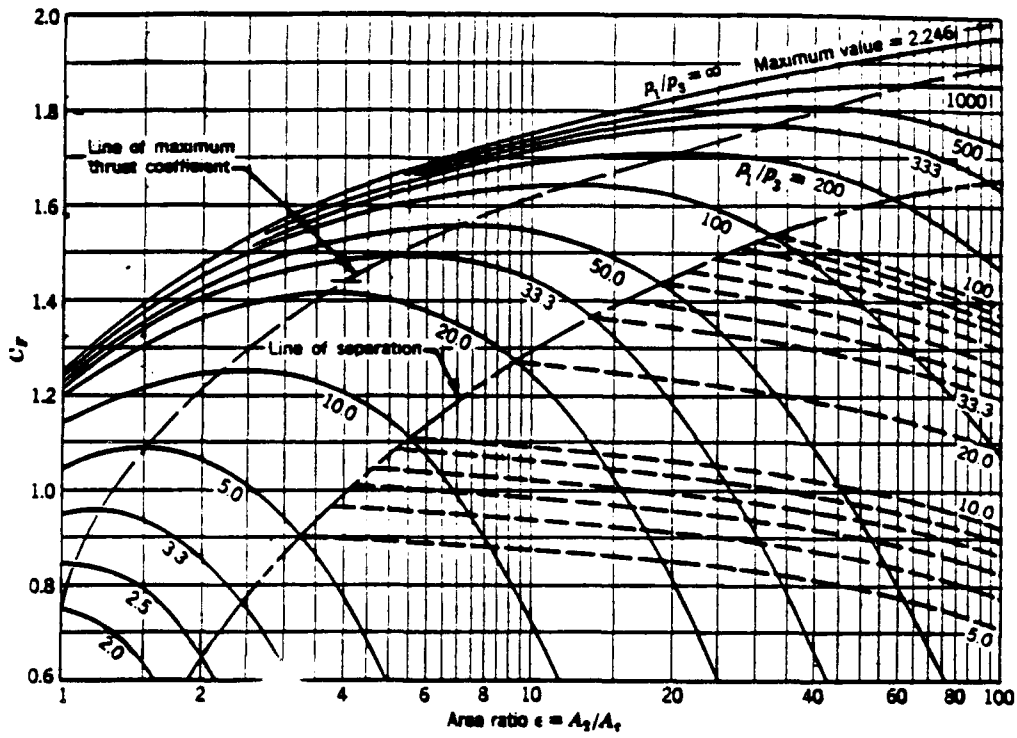

Thrust coefficient C_T versus area ratio ϵ for $\gamma = 1.20$.

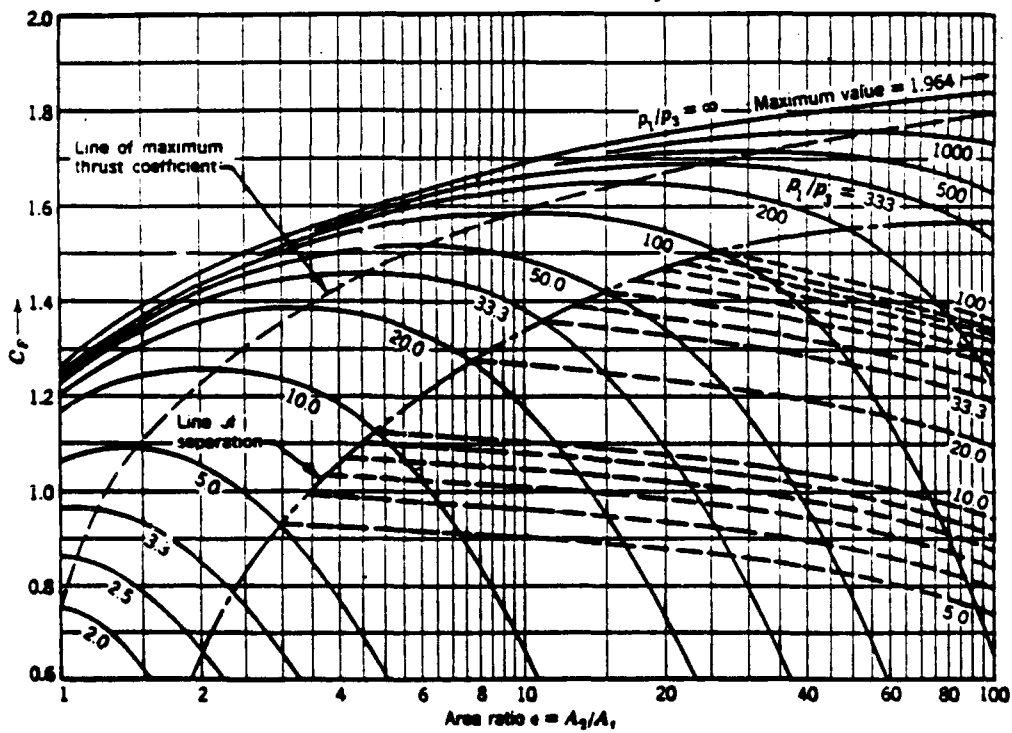

Thrust coefficient C_T versus area ratio ϵ for $\gamma = 1.30$.

Propulsion Equations

5.3 Total Impulse

The impulse, usually called the total impulse, of a rocket motor is the integral of the thrust, F , over the operating time, t . Mathematically, this is expressed as

$$I_T = \int_0^t F dt \quad (34)$$

(If you haven't had any calculus yet, don't worry we'll not linger on the subject). All the definition and equation mean is that the total impulse is equivalent to the area enclosed by the thrust versus time curve.

Units for total impulse are, as might be expected, **lbf-sec**.

The value for total impulse may be calculated easily by one of two means: count the squares. Plot the thrust history on a piece of graph paper, count the squares, and multiply that number by the unit value

or . . . Use the trapezoidal rule for figuring area. Approximate the curve with a series of trapezoids. The areas are calculated based on

$$\text{Area} = 0.5 * (\text{base}) * (\text{height}_1 + \text{height}_2)$$

then summed and multiplied by the unit area-value as before. Note that accuracy of the calculation improves as the number of trapezoids used increases.

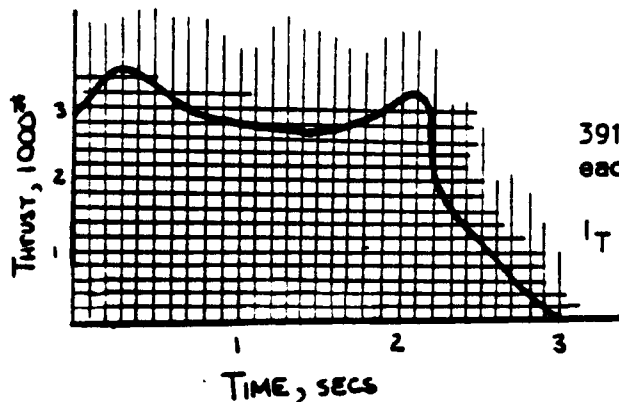
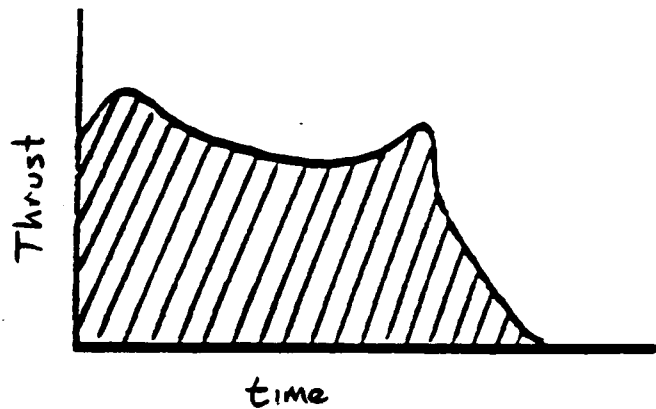

391 squares under the curve
each square represents 20 lb-sec

$$I_T = 391 \times 20 = 7820 \text{ lb-sec}$$

Propulsion Equations

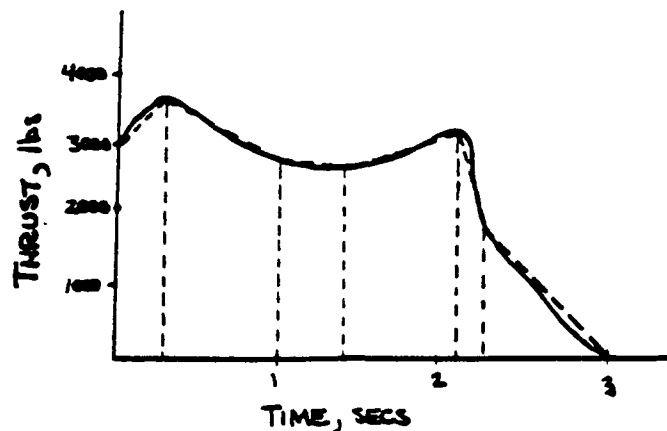

5.4 Specific Impulse

Total impulse was the impulse produced from burning all the propellant in the motor. We have a better reference for comparison of different motors if we ask, "How much impulse is produced by burning one pound of propellant?" This value is called the specific impulse and is calculated from

$$I_{sp} = \frac{I_T}{W_f} \quad (35)$$

or, at any instant

$$I_{sp} = \frac{F}{\dot{W}_f} \quad (36)$$

Where

W_f = total weight of the propellant (fuel) (lb).

\dot{W}_f = instantaneous weight flow rate of propellant (lb/sec).

F = instantaneous thrust.

Units for specific impulse are lbf-sec/lbm (or more generally, just seconds). The value of specific impulse is most significant in the determination of propellant weight necessary to meet ballistic requirements.

For comparing the values of the specific impulse of one rocket engine with another, or for evaluating the influence of various design parameters, the value of the pressure ratio P_e/P_c must be fixed; a chamber pressure of 1000 psia and an exit pressure of 1 atm (14.7 psia) is generally used today as a standard of comparison.

Characteristic Velocity

The characteristic velocity, C^* (c-star) defined as

$$C^* = \frac{g A_c P_c}{\dot{w}} \quad (37)$$

Propulsion Equations

Combined with the thrust coefficient, which is essentially a figure of merit of the motor design, the overall figure of merit of the rocket, specific impulse, can be written:

$$I_{sp} = \frac{C * C_F}{g} \quad (38)$$

Combining equations 28 and 37, we can also show

$$C * = \frac{\sqrt{\gamma g R T_c}}{\gamma \sqrt{\left(\frac{2}{\gamma + 1}\right)^{\frac{\gamma + 1}{\gamma - 1}}}} \quad (39)$$

C^* has units of ft/sec.

5.5 Burning Rate And Motor Pressure

As we have seen, the thrust of a rocket motor is proportional to chamber pressure. The thrust coefficient is also related to chamber pressure. It follows that if we can determine the pressure within the chamber we can determine motor thrust.

Pressure is produced by the burning of the propellant grain. Before we can determine what pressure a motor will have, we need to know how the propellant itself burns.

The velocity at which a solid propellant is consumed during operation is called the **burning rate**. It is measured in a direction normal to the propellant surface and is usually expressed in inches per second (ips). For most ordinary propellants, the burning rate at 2000 psi chamber pressure is between 0.03 and 2.5 ips. A grain which has, for example, a burning rate of 1.5 ips would have to be 45 inches long, if it is to burn for half a minute in cigarette fashion. For some restricted burning units, and for certain propellant combinations, the burning rate can be approximated by the following empirical relation, in which the influence of all performance parameters is small compared to the chamber pressure and the initial grain temperature.

$$r_b = a P_c^n \quad (40)$$

The burning rate or velocity of propellant consumption r_b is usually given in ips and the chamber pressure P_c in pounds per square inch: a and n are constants. For most restricted burning propellants, n has values between 0.4 and 0.85, and a is between 0.05 and 0.002. The constant, "a", varies with the initial propellant temperature, and thus the burning rate is a function of the temperature of the grain prior to combustion. The exponent "n" is essentially independent of the initial grain temperature.

Equation 40 is represented by a straight line in a logarithmic plot. The slope of the line is equal to the pressure exponent n . This is true because if we take the logarithm of both sides of equation 40:

$$\log r_b = \log (P_c^n)$$

$$\log r_b = n \log P_c$$

Which is in the form $y = mx + b$ a straight line with slope "n".

Propulsion Equations

The figures on this page show the burning rates of three propellants as a function of pressure for several values of the initial temperature T_i . It must be emphasized that the burning law written above is valid only within well specified ranges of pressures and temperatures. For instance, below a certain pressure, the combustion of a propellant may become unstable and possibly stop completely. Even at normal operating pressures it is not always possible to represent the burning rate versus pressure relationship by a simple equation of the form given above. For instance, the figure below represents the behavior of a plateau-burning composite propellant for which, for a given temperature, r_b is constant in a certain range of pressure. The burning law of such a propellant can be expressed by two equations

$$r_b = a_1 P_c^{n_1} \quad \text{for } P_c < 700 \text{ psi}$$

$$r_b = a_2 P_c^{n_2} \quad \text{for } P_c > 700 \text{ psi}$$

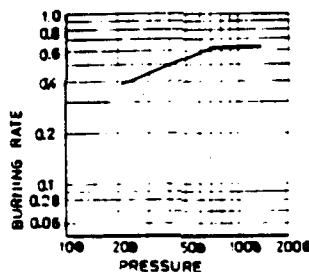
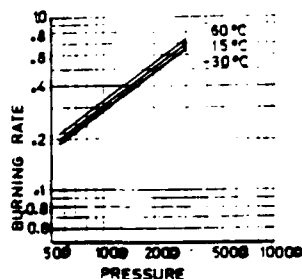

“plateau burning propellant”

A much more complicated case is shown in the figure below, which represents the burning rate versus pressure relationship of a mesa-burning, double-base propellant at normal temperature.

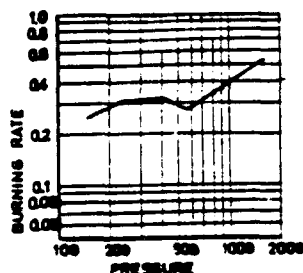

“mesa burning propellant”

More complicated forms of the burning law can possibly be found for describing such behavior but it seems easier to work graphically or rather to approximate the burning law in the logarithmic diagram by linear segments allowing the use of equation 40.

The burning rate may vary across the web thickness or along the grain length owing to a non-uniform distribution of chemical species (in some composite propellants the oxidizer particles concentrate near the middle of the web or at the bottom of the mold).

Propulsion Equations

5.6 Equilibrium Pressure

Rocket motor operation includes at least two highly transient processes, ignition and tailoff. (Dual or multithrust designs include other transition phases.) These processes, which last on the order of tens of milliseconds, are characterized by a rapid change of chamber pressure. The intervening period, which typically lasts on the order of seconds, exhibits comparatively small pressure changes with time. For most purposes, motor operation during this period can be regarded as a steady state process. Mathematical relations are then considerably simplified and the effect of the governing parameters becomes more apparent.

Steady operation implies that there is no net accumulation of propellant gas within the combustion chamber. Thus, the principle of conservation of mass specifies that the rate of generation of gas by the burning of the propellant is equal to the rate of gas discharge through the nozzle.

$$\dot{W}_G = \dot{W}_D \quad (41)$$

Where \dot{W} = gas flow rate in lbm/sec.

The weight rate at which propellant gas is generated is, of course, also just the rate at which the weight of the solid propellant is diminished. A solid propellant grain burns perpendicularly to its exposed surface (ie. in parallel layers). We'll discuss this characteristic in depth later. For now, consider a small time increment, Δt . During this small time increment the burning surface, A_s , which may be regarded as unchanging, has regressed a distance, Δx .

The volumetric change of the solid propellant is just $\Delta x A_s$ and multiplying by the propellant density, ρ_p , yields the mass change.

The gas generation rate is then,

$$\dot{W}_G = \frac{\rho_p \Delta x A_s}{\Delta t}$$

but, $\frac{\Delta x}{\Delta t}$ is the propellant burning rate, r_b .

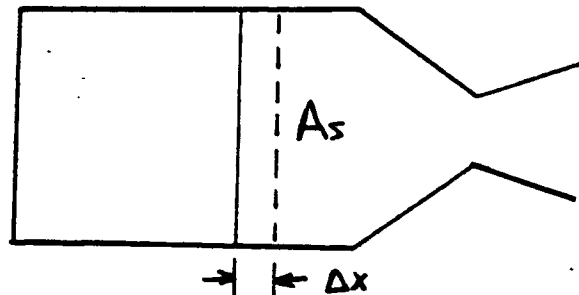

$$\dot{W}_G = \rho_p r_b A_s \quad (42)$$

Where

- \dot{W}_G = gas generation rate (lb/sec).
- ρ_p = propellant density (lb/in³).
- r_b = burning rate (in/sec).
- A_s = burning surface (in²).

The discharge rate can be determined from equation 37

$$\dot{W}_D = \frac{g A_t P_c}{C^*}$$

Propulsion Equations

Our Conservation of Mass Equation now looks like,

$$r_b \rho_p A_s = \frac{g A_t P_c}{C^*} \quad (43)$$

but, remember, we can express burn rate as

$$r_b = a P_c^n$$

So,

$$a P_c^n \rho_p A_s = \frac{g A_t P_c}{C^*} \quad (44)$$

Collecting P_c terms and re-arranging, we have

$$P_c = \left(\frac{a \rho_p A_s C^*}{g A_t} \right)^{\frac{1}{1-n}} \quad (45)$$

This is the **Equilibrium Pressure Equation** and is one of the most-used expressions in internal ballistics. It is well worthwhile to memorize this equation. It establishes the pressure at which a given rocket will operate. Inspection of this Equilibrium Pressure Equation reveals three separate categories of parameters which affect motor pressure:

- (1) Propellant - density, characteristic velocity, burning rate coefficient, and exponent,
- (2) Nozzle - throat area,
- (3) Grain - burning surface.

A moment's study of equation 45 generates a wealth of information about solid rocket motor performance. If any parameters in the numerator increase, so does pressure and thrust, (remember equation 33?) If the throat area is increased, pressure drops. Also, note that motor pressure is independent of the exit area of the nozzle.

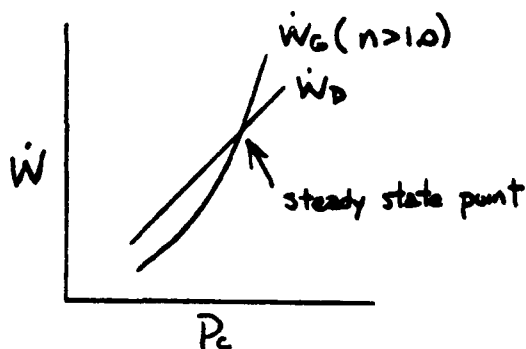

It takes a bit more study to see the significance of burning rate exponent. If the value of n is greater than 1.0, the generated mass will be more sensitive to pressure changes than will the discharged mass (eq. 44) as depicted.

Should a small perturbation cause a slight increase in P_c above the steady state, the mass generation rate will exceed the nozzle's ability to exhaust it. An even higher pressure results from the accumulated mass in the chamber, driving the process still further. Catastrophic failure results.

If the disturbance causes a reduction in P_c below the steady state point, more mass will be discharged than generated and pressure will drop further. Clearly for n greater than 1.0, operation is highly unstable. The motor will either extinguish or explode.

Propulsion Equations

On the other hand, if n is less than 1.0, the operation remains stable about the steady state point. By the same arguments as above, small perturbation will not lead to unstable operation. The motor will return to the steady state point.

Thus, to be usable as a solid rocket propellant, an energetic compound must possess a burning rate slope less than one. The slope can, in fact, be negative! (See if you can argue that negative exponents in propellants yield stable operation).

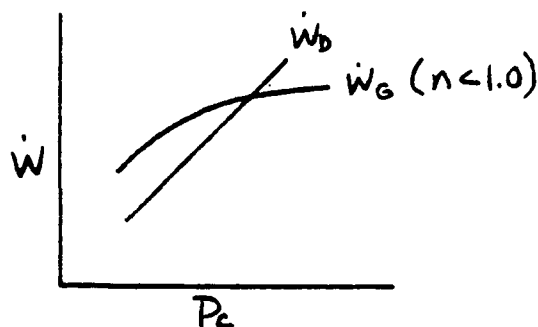

Exponent values greater than 1.0 are undesirable, but how close can we get to $n = 1$? How sensitive is performance to high values for n ? An example will clarify:

Let's assume that condition #1 is during normal operation. If we crack our propellant grain such that the burning surface increases 10%, what is the effect on pressure? Let's denote our cracked grain pressure as P_2 .

We can ratio our equilibrium pressure as

$$\frac{P_2}{P_1} = \left(\frac{A_{s2}}{A_{s1}} \right)^{\frac{1}{1-n}}$$

(Note that all of the other terms in equation 45 are constant between states 1 and 2 and, therefore, cancel out when we ratio.)

For a ten percent increase in burning surface, we can tabulate the corresponding equilibrium pressure for several exponent values:

n	ΔP
0.00	10%
0.25	14%
0.50	21%
0.75	46%
1.00	∞

The disadvantage of high exponent propellants is obvious. The advantage of a plateau ($n = 0$) is equally clear.

We've come a long way since our discussion of good old $F = ma$. So far we've been focusing on what goes on inside the rocket motor. As a brief diversion, let's ask now how fast will the rocket go when we ignite it. The subject of **external ballistics** – or trajectory simulation is not going to be addressed in this text. Its equations and theories are separate from those we have been (and will be) addressing. We should, however, touch on a flight performance topic that we can tackle with our knowledge of internal ballistics.

Propulsion Equations

5.7 Ideal Burnout Velocity

How fast will a given rocket go? Which parameters are important in maximizing the velocity at burn-out? Newton said that the momentum change of our rocket is equal to the momentum change in the gas exhausted from it, (action . . . reaction, remember?)

Rocket momentum change = gas momentum change

$$M_R \frac{\Delta V_R}{\Delta t} = \frac{\Delta M_{\text{gas}}}{\Delta t} V_{\text{exit}}$$

but,

$$\Delta M_{\text{gas}} = -\Delta M_R$$

so,

$$\Delta V_R = -V_{\text{exit}} \frac{\Delta M_R}{M_R}$$

where ΔV_R = the change in velocity of the rocket.

If we designate with subscript "i" those conditions present before the motor is ignited and "bo" for conditions at burn-out, we can integrate the above equation to give: (If you haven't had calculus, this is a step you've just got to take on faith!)

$$\begin{aligned} V_{\text{bo}} - V_i &= -V_{\text{exit}} [\ln M_{\text{bo}} - \ln M_i] \\ V_{\text{bo}} - V_i &= -V_{\text{exit}} \ln \left(\frac{M_i}{M_{\text{bo}}} \right) \end{aligned} \quad (47)$$

We also know from Newton, that

$$F = \dot{M}_{\text{gas}} V_{\text{exit}}$$

(remember equation 30?)

Re-arranging

$$\begin{aligned} V_{\text{exit}} &= \frac{F}{\dot{M}_{\text{gas}}} \\ &= \frac{I_T}{t_{\text{bo}}} \frac{g}{w} \\ &= g \frac{I_T}{w_T} \\ &= g I_{\text{sp}} \end{aligned} \quad (48)$$

Propulsion Equations

Combining equations 48 and 47, we get

$$V_{bo} = gI_{sp} \ln \left(\frac{M_i}{M_{bo}} \right) + V_i \quad (49)$$

This is the **ideal burnout velocity** equation. It's called ideal because it assumes neither aerodynamic drag nor gravity acts on the rocket. This shows the importance of I_{sp} (velocity is directly proportional to it). Since,

$$M_i = M_{bo} + M_{propellant}$$

we have,

$$\frac{M_i}{M_{bo}} = 1 + \frac{M_{propellant}}{M_{hardware}}$$

and we can see that as we increase the "energetic portion" of our rocket, velocity (logically) increases.

5.8 Temperature Sensitivity

Practical experience shows that burning rate is not a function of pressure alone, but also one of pre-ignition propellant temperature. Since many rocket motors must be operated over temperature ranges of 200°F (from arctic to desert environments), the impact of temperature on burning rate (and thus motor pressure) must be evaluated.

A set of burning rate curves for a typical propellant is shown below together with the effects on motor performance.

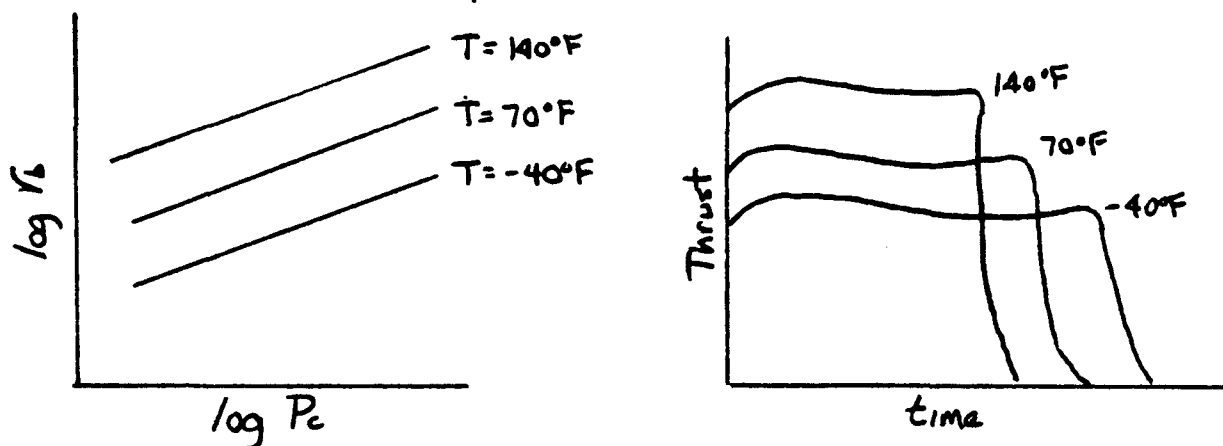

As shown above, if the initial temperature T_i of the propellant decreases, the burning rate coefficient "a" diminishes together with the thrust and chamber pressure of the motor, but the burning time increases

Propulsion Equations

If the initial temperature is too low, the chamber pressure may not become high enough to sustain a smooth combustion, and intermittent burning, called chuffing, may occur. Inversely, at high initial temperatures, the total impulse rises somewhat, but increases in chamber pressure may become important and must be taken into account in the design of the chamber.

This phenomenon is called the **thermal sensitivity** of solid propellants. It limits narrowly the allowable range of operational temperature and represents a severe drawback. Indeed a rocket motor will malfunction if its temperature does not lie between certain limiting temperatures. As temperature is varied, the burning rate line shifts upward or downward on the chart with little or no change in the slope of the line (n). In order to evaluate the effect of temperature on a rocket motor, it is necessary to know how pressure changes at a fixed burning surface area and nozzle throat area (fixed motor design). The ratio A_b/A_t is often given the symbol K_N . It has become standard practice to express the pressure change as a percentage of the mean pressure in the range of interest by defining a temperature sensitivity coefficient at constant K_N , π_K . For example,

$$\pi_K \equiv \left. \frac{\delta \ln P_c}{\delta T} \right|_{K_N} \quad (50)$$

So,

$$P_2 = P_1 e^{\pi_K(T_2 - T_1)} \quad (51)$$

which can be approximated by,

$$\pi_K \approx \left. \frac{\Delta P_c / P_c}{\Delta T} \right|_{K_N} \quad (52)$$

so that,

$$\frac{\Delta P_c}{P_c} \approx \pi_K \Delta T \quad (53)$$

Typical values for π_K are 0.001 to 0.003.

It should be noted that the pressure variation with temperature can also be obtained from the burning rate curves graphically. Since K_N is constant as are ρ and C^* , the Mass Balance Equation (eq. 43) can be written

$$P_c = \text{constant} * r_b$$

which is a line of unit slope (45°) on log-log burning rate plots. This is because if we take the log of both sides, we get

$$\log P_c = \log r_b + \text{constant} \quad \text{or}$$

$$\log r_b = \log P_c + \text{constant}$$

which conforms to the equation for a straight line with slope of one (45°).

Propulsion Equations

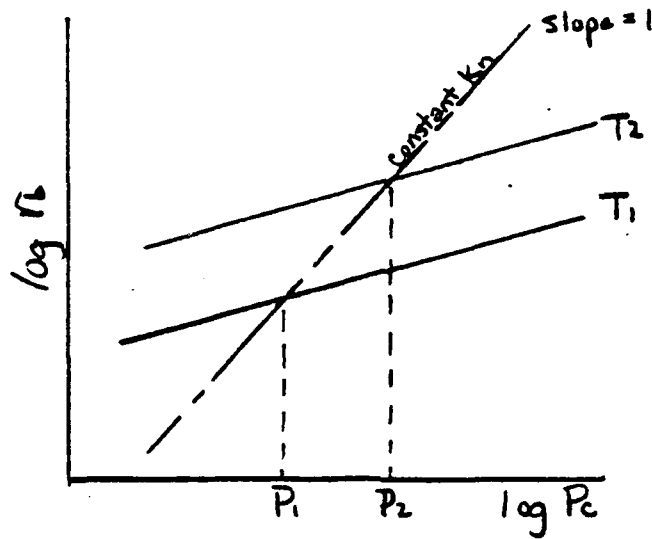

The intersection of this line with the burning rate curve represents the stable operating point for a given motor and propellant. Thus, if the operating pressure, P_{T1} , for a rocket motor is known at temperature T_1 and the burning rate curves are available for that and another temperature, T_2 , the operating pressure at the new temperature P_{T2} can be determined by drawing a 45° line through the first point and noting the intersection with the other burning rate curve, as shown above.

5.9 Nozzle Divergence Loss

Equation 31 was derived with the assumption that the gas flow from the nozzle takes place only along the axis of the nozzle. In reality the gases are expanding with a radial component, so the velocity in the axial direction (and the thrust) must be corrected to reflect this expansion.

All streamlines are assumed to originate in the apex of the diverging cone, so that surfaces of constant properties become sections of spheres with their center at T . The exit surface of constant properties is indicated by A_s . If we define a factor related to the nozzle half-angle, α as

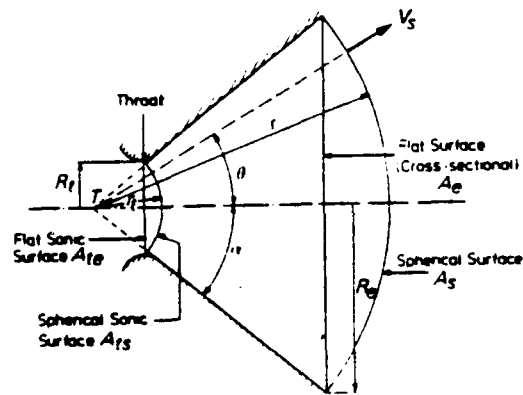

Conical nozzle flow

$$\lambda = \frac{1 + \cos(\alpha)}{2} \tag{54}$$

Propulsion Equations

it can be shown that by correcting thrust for the non-axial flow, the Thrust Equation becomes

$$F = \lambda \dot{m} V_{\text{exit}} + (P_e - P_{\text{atm}}) A_e \quad (54)$$

which reverts to equation 31 if $\alpha = 0^\circ$.

The loss in thrust due to sideward components of the exhaust velocity is called the divergence loss. In general, it amounts to a few percent only. For exit cones of 17° and a spherical exit surface, it is only 2.2 percent of the momentum thrust. This loss can be reduced by the use of contoured nozzles which are also advantageous in other respects. These contoured nozzles diverge rapidly after the throat but the divergence diminishes with increasing distance from the throat, to vanish towards the exit. Then the exhaust velocity is parallel or nearly parallel to the axis of symmetry and λ is very near to unity for such a nozzle.

5.10 Optimum Thrust

The thrust, F , is the sum of the momentum thrust and the pressure thrust. Both depend on the exit pressure, P_e . With decreasing exit pressure the impulse thrust will increase, due to the increase in exhaust velocity, while the pressure thrust will decrease. It follows from physical reasoning that the maximum thrust is obtained when there is no pressure thrust. Therefore, consider the figure below, which shows a part of the nozzle. The ambient pressure, P_a , acts on the outside of the nozzle wall, while the pressure of the combustion products acts at the inside of the wall. The pressure decreases continuously towards the exit. The thrust actually is due to the pressure forces acting on the nozzle and chamber walls. At some point B , the pressure at the inside of the nozzle wall equals the ambient pressure. A nozzle with its exit area located at point A would gain an extra thrust F_{AB} by lengthening it to B , due to the fact that over interval AB the pressure at the inside of the nozzle wall is larger than the ambient pressure at the outside. If one would lengthen the nozzle from B to C then the fluid

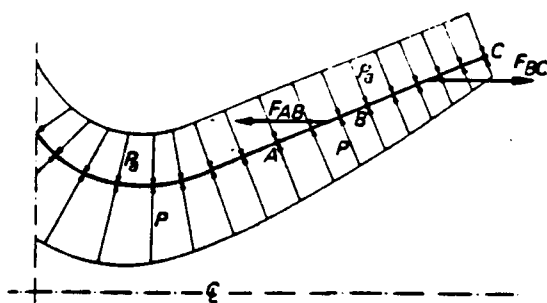

The pressure on a rocket nozzle

pressure, P , is smaller than the ambient pressure. Over the interval BC the resultant force is directed backwards, and therefore diminishes the thrust. These arguments hold for all types of converging-diverging nozzles which therefore should expand to ambient pressure to achieve a maximum thrust.

In actual flight, the ambient pressure depends on altitude and it is not possible to expand to ambient pressure during the whole powered flight. One may design the nozzle in such a way that the exit pressure is a weighted average of the ambient pressure during the powered flight. If the rocket motor is to operate in vacuum, the compromise between weight, thrust, costs, size, and strength will determine the actual dimensions of the nozzle.

Propulsion Equations

5.11 The Effect of Ambient Pressure on Nozzle Flow

We have just seen that maximum thrust occurs when the exit pressure, P_e equals the ambient pressure, P_a . The situation when P_e is greater than P_a is called under-expansion since more expansion of the exhaust is still possible. In the case when P_e is less than P_a , we speak of the flow as being "over-expanded". Because of the decrease in ambient pressure with altitude, both under-expansion and "over-expansion" actually occur during the flight of a rocket. If the over-expansion is too large, shock waves may occur within the nozzle. The shock wave itself is due to viscous effects. Across the shock, there is a sudden rise in temperature, pressure, and density, while the velocity is decreased. At this time the flow separates from the nozzle wall. Behind the shock waves the flow contracts and a wake with approximately atmospheric pressure arises.

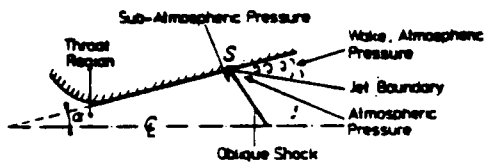

Separation and oblique shockwave in a nozzle due to over-expansion

The nozzle now acts as if it had a smaller expansion ratio. There is a classic rule-of-thumb which indicates when separation may occur.

$$\frac{P_e}{P_c} < 0.3 \left(\frac{P_{atm}}{P_c} \right)$$

CHAPTER VI DESIGN TOPICS

If you've been feeling intimidated by all the equations we've recently covered, take heart. We've covered 90% of them by this point. From here on out we will be "fine tuning" what we've learned and broadening our knowledge of design-related subjects. Hopefully, these topics will add a real-world facet to our (so far) idealized view of rocket performance.

These topics, as we mentioned a few sections back, are generally second or third order in importance to the major areas like equilibrium pressure. Some of them can, however, make the difference between a successful motor test and a blow-up. Gremlins that alter burning rate or pressure go by names such as "mass addition", "erosive burning", "spin effects" and "transient operation". We'll address each of these and provide examples of the consequences you may have to pay if you choose to ignore the real world.

So far, we've assumed ideal performance. Mother nature is fickle to say the least and loves to cross us up. Usually what happens is that idealized performance is better than that actually measured. In other words, there are "losses" associated with actual performance which tend to degrade our ideal performance. We've gotten a handle on some of these and we'll discuss them, too. "Two-phase flow" and "recombination loss" are terms we'll encounter as we compare fact vs. fiction. The scope of many real world aspects to motor performance is well beyond this text. Indeed, they are not well understood by scientists yet. The major ones are mentioned, however, so that you will have a better understanding of the subtleties of motor performance prediction. (In any event, exposure to the terminology may prove beneficial).

Let's begin by addressing one of the major topics affecting performance prediction: the so-called "mass addition" phenomena.

6.1 Mass Addition

Most designers of high performance rocket motors are concerned with packing as much propellant (energy) as possible into the available chamber volume. This means that in many designs, the flow area or port for the gases within the chamber is rather small. What results is a situation of high mass flux (mass flow per unit flow area). In motors of this type, the momentum of the combustion gases can alter the pressure distribution within the chamber. Here's how. Lets look at a single "lump" of gas within the motor.

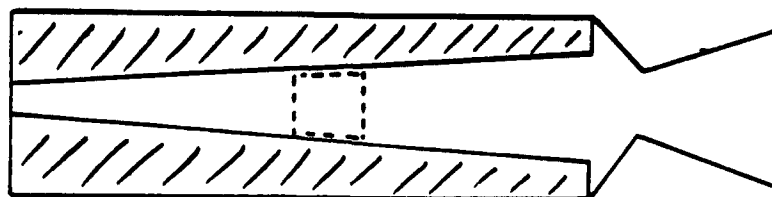

Design Topics

Let's isolate this segment and look at the forces acting on the gas.

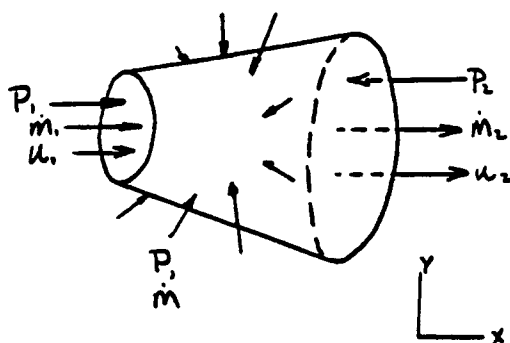

We can see that entering the elemental volume with velocity U_1 , we have a quantity of gas \dot{M}_1 . Acting on this front "face" of the element is pressure P_1 . Leaving the element with velocity U_2 is gas at the rate \dot{M}_2 , and acting on the rear face, A_2 , is pressure P_2 .

Mass also enters our volume through the lateral surface from combustion of the propellant. We have purposely allowed our flow area to be conical so that pressure and momentum have both X and Y components for the lateral surface. A moment's thought will confirm that the Y-components of pressure and momentum "cancel" on opposite sides of the volume, so we need to concern ourselves only with the X, or axial, components. We approximate the axial pressure force on this lateral surface by using the average pressure, $(P_1+P_2)/2$ acting on the difference in areas, $(A_2 - A_1)$. We also assume that all mass crossing this lateral boundary does so with no axial component of velocity.

Recalling our steady state momentum relationship a la Newton:

The sum of the forces on the gas = the change of momentum of the gas.

We have (for the axial components only)

$$P_1 A_1 - P_2 A_2 + \left(\frac{P_1 + P_2}{2} \right) (A_2 - A_1) = \dot{M}_1 U_1 - \dot{M}_2 U_2$$

or, by rearranging

$$P_2 = P_1 - \frac{2(\dot{M}_2 U_2 - \dot{M}_1 U_1)}{(A_1 + A_2)}$$

This expression relates the pressure drop through the element in terms of mass flow rate, gas velocity, and flow area.

Lets go back to our motor cross-section now, and imagine a series of these elements, one after the other, for the full length of the motor. Each element has as input, the output conditions from the previous element. If we sum the individual pressure drops for each element, we can arrive at the total pressure change down the motor due to mass addition.

An approximate expression has been established which relates motor head end pressure to "average" motor pressure.

Design Topics

$$\frac{P_h}{P_c} = 1 + \left[\frac{\gamma}{2} \left(\frac{2}{\gamma + 1} \right)^{\frac{\gamma}{\gamma-1}} \right] \left(\frac{A_t}{A_p} \right)^2$$

In this equation, P_h = pressure measured at the motor head end.

P_c = our old friend, the equilibrium pressure.

A_t = nozzle throat area, in².

A_p = port area (flow area) for the gas, in².

We can see that as the port area is decreased, the ratio of head end-to-equilibrium pressure grows. This means that our motor design pressure could be significantly above that derived from equilibrium. If we fail to include mass addition in our design calculations, our motor could be under designed and could fail. Boom! The motor designer usually tries to maintain an initial port area of at least twice the throat area to reduce the impact of mass addition on design calculations.

As you may expect, mass addition is most important early in the motor burn when the port area is smallest. As the grain continues to burn, the port area opens and the mass addition influence is reduced.

Other approaches to mass addition may be taken. The above expression was an approximation. A second approach, one using more complex theories, was developed at Morton Thiokol Corporation/Huntsville Alabama. Results of this work are summarized in the figure below.

The curve is simple to use. Consider any axial location, x , within a motor. We want to know the Mach number of the gas at this location and the decrease in pressure from the motor head end to location " x ".

We first calculate two parameters, " K_x " and " K_n ". We have already encountered K_n . It's just the total propellant burning surface divided by the throat area. The second term, K_x , is another area ratio term.

$$K_x = \frac{A_{sx}}{A_{px}}$$

where A_{sx} = propellant surface area between head end and location " x ", in²

A_{px} = port area at location " x ", in²

Armed with K_x and K_n , we ratio them and go to the curve to read off pressure drop and Mach number at location " x ".

Let's try an example.

Given the following motor configuration

Throat area = 2.5 in²

Total burning surface = 400 in²

Constant port area over whole length of grain = 7 in²

What is the Mach number and pressure drop at a point 80 percent down the grain (from the head end)?

First, we determine K_n

Design Topics

$$K_n = \frac{A_s}{A_t} = \frac{400}{2.5} = 160$$

For a constant port, at 80 percent of the grain length, we have 80 percent of the total burning surface, so,

$$K_x = \frac{A_{sx}}{A_{px}} = \frac{0.8 * 400}{7} = 45.71$$

so,

$$\frac{K_x}{K_n} = \frac{45.71}{160} = 0.286$$

We read from the curve at this value

$$M_x = 0.17$$

$$\frac{P_x}{P_h} = 0.978$$

Try to show that if location x is at the aft end of the grain, $\frac{K_x}{K_n} = \frac{A_t}{A_p}$

Design Topics

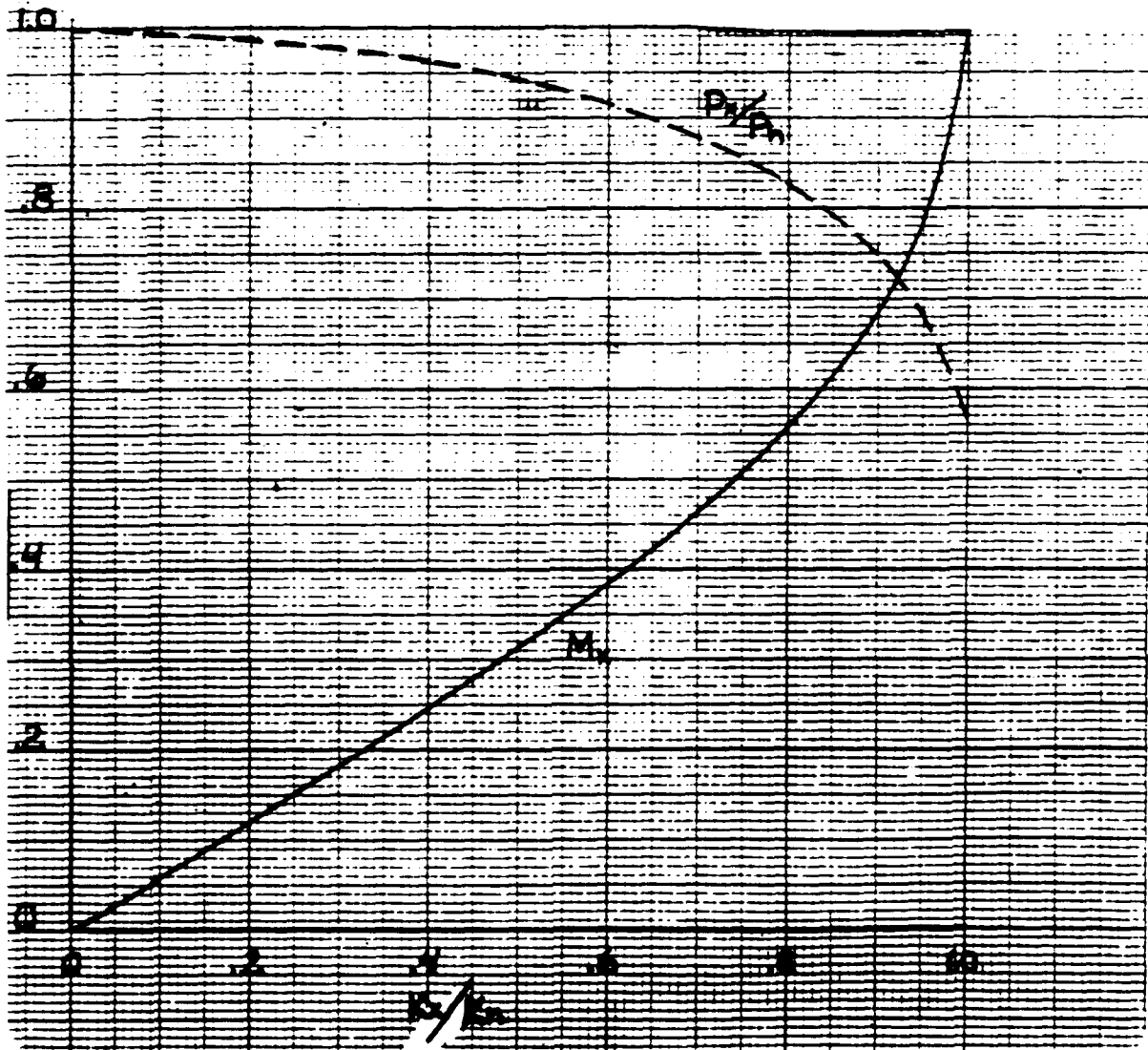
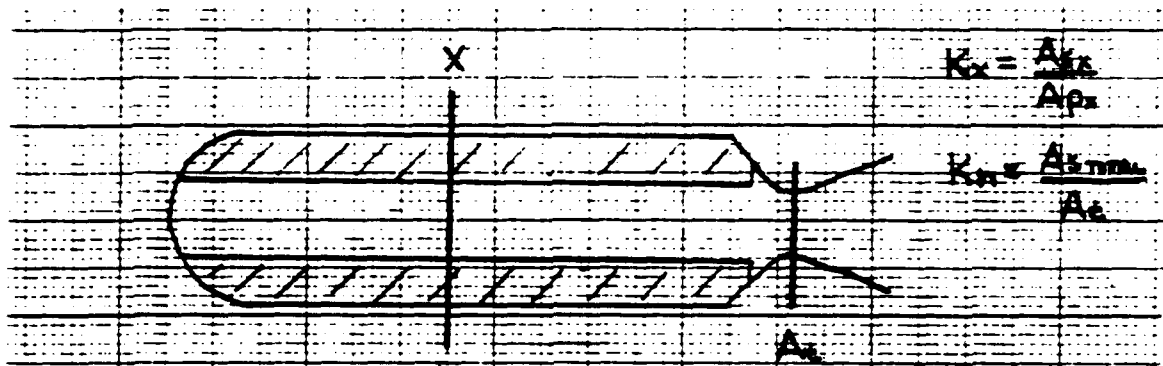

Design Topics

6.2 Erosive Burning

As gases leave the burning surface, they are accelerated on their trip down the port to the nozzle. Rapid flow of these gases tends to increase the burning rate of the propellant surfaces over which they pass. Why?

The jury is still out on this question. Two scenarios exist: (1) It is believed that the gases sweep past the burning surface as ocean waves sweep over a beach, eroding particles from the surface and sweeping them away. This mechanical abrasion would be perceived as a "faster burning away" of propellant. (2) It is believed that increased velocity (and turbulence in the flow) increases the feedback of heat to the burning surface, thus increasing the burning reaction rate.

These two camps have been fighting for years and the debate will no doubt continue. Rather than get bogged down in their mire, let's look at some of the effects of and observations about erosive burning.

Erosive burning is more severe in designs with small ratios of port area to throat area (A_p/A_t). We've just seen that it is in these cases when gas velocity is higher.

The effect of erosive burning is greatest at ignition. (That's when (A_p/A_t) is the smallest).

What does this mean to performance? Consider the pressure histories below:

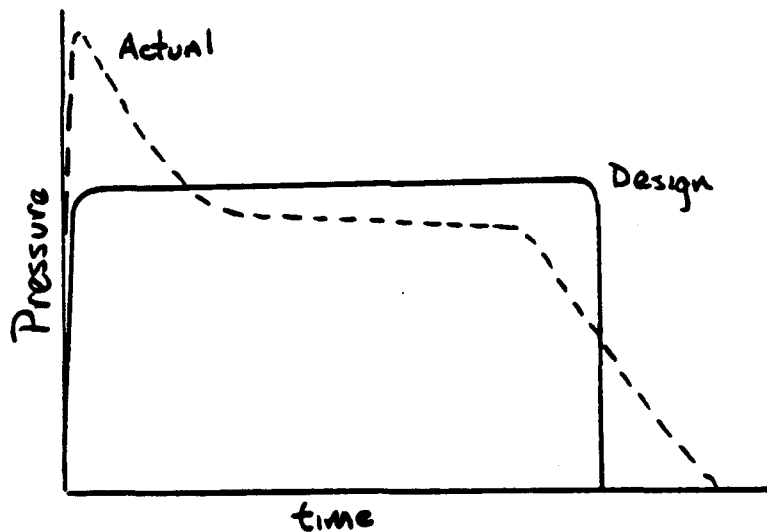

We've designed our motor to have a flat pressure time history, but when we test it we see several unexpected characteristics. We note that our actual pressure is peaked at ignition and soon regains roughly the "design" pressure. This peak in pressure is a major clue to indicate the presence of erosive burning. It is high very early in burn and diminishes as the port becomes larger. But why should our "tail-off" of pressure at the end of burn be so extended? We've designed the grain to burn out all at once, so pressure should drop off rapidly. Is this also a result of erosive burning? Yes. Here's why.

Design Topics

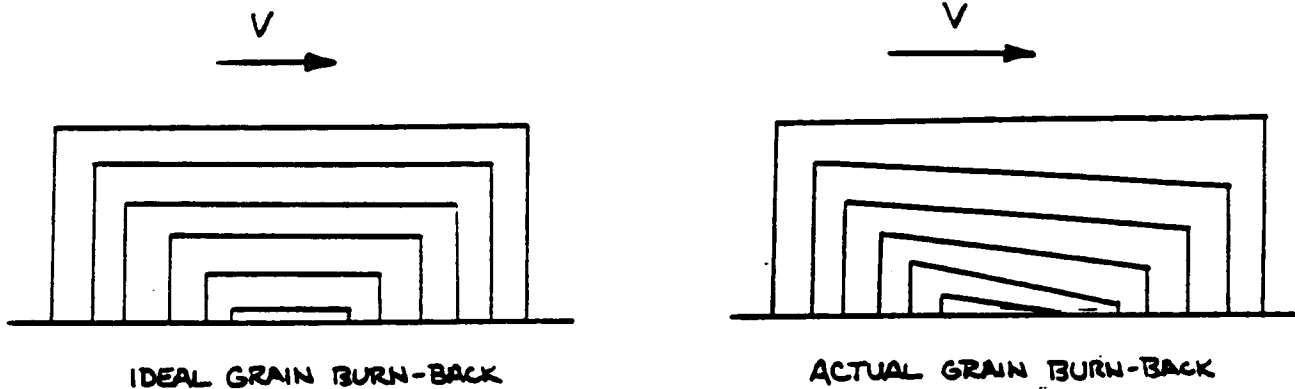

The high velocities at the grain aft end cause the propellant to regress faster in that region. This alters the ideal burn back pattern and results in an anomalous tail-off. Burnout of the aft end actually occurs earlier than expected (and well before the head end).

It's clear that we are unclear about the facts concerning erosive burning. Most of the work on erosive burning is on an empirical or semi-empirical basis (based on experiment). Studies have indicated that:

- (1) Slow burning propellants are more prone to erosive burning than are fast burning propellants
- (2) Flame temperature appears to have influence on erosive burning
- (3) Propellant grain geometry does influence erosive burning (as we have seen).
- (4) There appears to be a threshold effect. This means that below a critical gas velocity erosive burning does not come into play. Once that critical velocity is exceeded, however, erosive burning becomes important. This threshold velocity appears to be somewhere in the neighborhood of 250-300 ft/sec. If we plot burning rate enhancement (or erosive burning rate r_b divided by non erosive burning rate r_o) against velocity (or Mach number), we would produce on chart like this one.

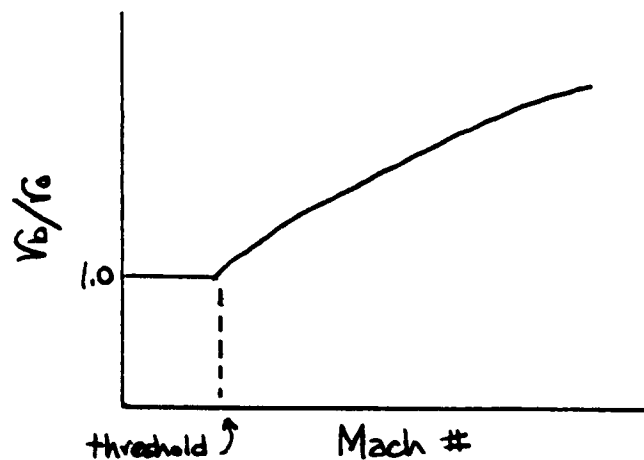

Many ballisticians use an empirical expression for erosive burning known as the Saderholm model.

$$r_b = aP_c^n \left(\frac{M}{M_c} \right)^x \quad \text{for } M > M_c$$

Typical values used are M_c (threshold Mach number) = .07 and $x = 0.5$.

Design Topics

Spin Effects

Many rocket propellants contain finely ground metals such as aluminum which act as a fuel during combustion. As the flame front encounters these particles, they melt and are swept into the gas stream where they continue to "burn" or oxidize releasing a great deal of heat. If the motor is rapidly spinning about its axis (as many indeed are for flight stability), centrifugal forces may cause these molten particles to be held against the grain surface where they enhance the burning rate through increased heat transfer.

Symptoms of spin effects may include:

- Increased motor pressure (from increased r_b).
- A decrease in burn time from that expected.
- An extended tail-off.
- Case overheating.

As one might expect, spin effects become more important as spin rate increases or as the amount of metal in the propellant increases.

6.3 Transient Operation

Earlier, we developed an expression for equilibrium chamber pressure based on conservation of mass; gas generated by the burning propellant is equal to the gas discharged through the nozzle. This is fine for most of the motor operation. But what about start-up and shut-down of the motor? In the start-up, the motor pressure is highly transient as it goes from atmospheric to operating pressure in milliseconds. During shut-down, the propellant has been consumed already, but there is still high pressure in the chamber which must "blow down."

During ignition, some of the gas generated by the burning propellant escapes through the nozzle and some remains in the chamber as pressure rises. We then must re-write our Mass Balance Equation to read

$$\dot{W}_G = \dot{W}_D + \dot{W}_S$$

where

\dot{W}_G = rate of gas generation (lbm/sec)

\dot{W}_D = rate of gas discharge (lbm/sec)

\dot{W}_S = rate of gas storage in the chamber (lbm/sec)

This stored mass serves two purposes,

- (1) gas remains in the chamber to increase the pressure
- (2) gas remains in the chamber to fill the void left by the receding solid propellant surface.

Mathematically

$$A_s r_b \rho_p = \frac{P_c A_t g}{C^*} + \left[\frac{V \frac{\Delta P_c}{\Delta t}}{12RT_c} + \frac{P_c \frac{\Delta V}{\Delta t}}{12RT_c} \right]$$

Design Topics

where

V = gas volume, in³

12 = a required units conversion factor since pressure and volume are in terms of inches and the gas constant, R , is in ft/°R

But, the time rate of change of gas volume is just the volumetric regression of the propellant ($r_b \cdot A_s$)

So,

$$A_s r_b \rho_p = \frac{P_c A_t g}{C^*} + \frac{V \frac{\Delta P_c}{\Delta t}}{12 R T_c} + \frac{P_c A_s r_b}{12 R T_c}$$

or,

$$\frac{\Delta P_c}{\Delta t} = \frac{12 R T_c}{V} \left[A_s r_b \left(\rho_p - \frac{P_c}{12 R T_c} \right) - \frac{P_c A_t g}{C^*} \right]$$

This is our **Transient Pressure Equation**. It applies to either the ignition or tail-off phase.

The equation describes the slope of the pressure curve as a function of the instantaneous conditions (pressure, burn rate, free volume, burning surface, etc.) within the motor. To calculate an ignition transient pressure history, the following procedure is used:

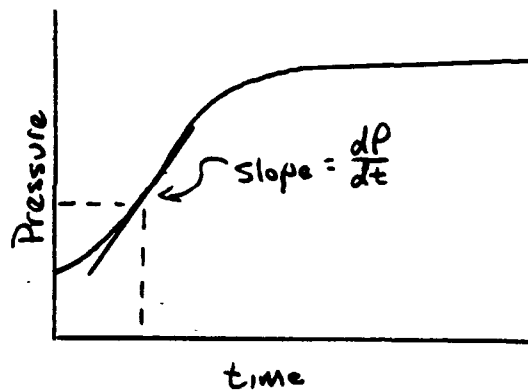

- (1) Assume as a starting pressure the pressure to which the igniter pressurizes the motor. (Say, 50 psi)
- (2) Calculate the burning rate at that pressure from equation 40.
- (3) Use that pressure and rate in the Transient Equation together with the initial gas volume, burning surface, etc to calculate the slope, $\Delta P_c / \Delta t$.
- (4) Establish a time step increment, say .002 sec, and calculate the pressure after this increment.

$$P_2 = P_1 + \left(\frac{\Delta P_c}{\Delta t} \right) \Delta t$$

This defines a point on your pressure-time transient.

- (5) Take as your new starting pressure, the pressure you just calculated and go back to step 2.

You will find as you repeat these steps over and over that pressure will rise and become asymptotic to the value we would calculate from the Equilibrium Pressure Equation.

Design Topics

During tail-off, we usually have no burning surface ($A_s = 0$), so our Transient Equation reduces to

$$\frac{\Delta P_c}{\Delta t} = -\frac{12RT_c}{V} \left(\frac{P_c A_t g}{C^*} \right)$$

for tail-off.

Where, in this case, V corresponds to the empty chamber volume.

The procedure to calculate a tail-off transient is identical to the one we used for ignition, only now our starting pressure is the last equilibrium pressure the motor had just before tail-off began.

Notice the minus sign in our tail-off equation. This indicates that the slope is always negative and pressure will always be decreasing.

6.4 Nozzle Area Variation

Contrary to all our previous discussions, A_t can and does vary during a motor firing. Throat materials (steel, graphite, phenolic) erode during a test. Specific impulse can be degraded due to reduced pressure, reduced expansion ratio and increased nozzle surface roughness. Recent studies have indicated that metal oxides from the combustion products can build up on a cold nozzle immediately following ignition, reducing throat area. These deposits are discharged when (1) the nozzle surface temperature exceeds the oxide melt temperature or (2) gas dynamic drag exceeds the strength of the deposit.

Allowance for nozzle variation is necessary in making accurate performance predictions. One method uses experimental data for each nozzle throat material to establish the constants C_1 and C_2 in the expression

$$r_e = C_1 P_c^{C_2}$$

where r_e = throat erosion rate in ips.

Typical values for C_1 and C_2 appear in a table in the Appendix.

6.5 Miscellaneous Losses

Two-Phase Flow Loss

It has already been mentioned that many propellants contain metal which exist in the gas free stream in either a molten or solid state. Presence of these "condensed species" results in a reduction in the overall performance of the motor. This is because the condensed particles fail to gain momentum or thermal energy as quickly as

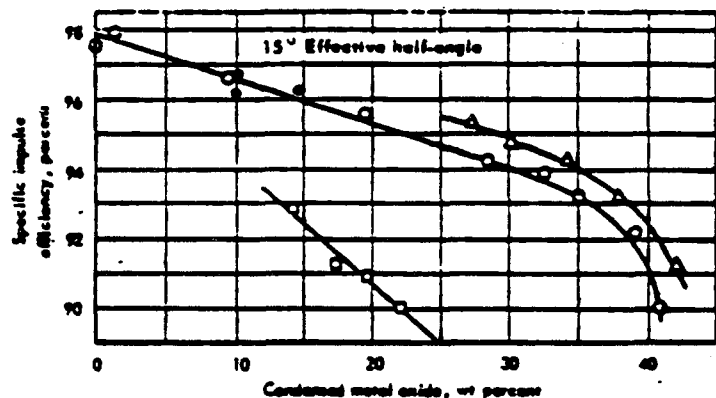

Design Topics

the gas. They gain motion only from drag forces. Its like placing a heavy raft into a swiftly running river. Initially, water rushes all around the raft until the drag forces of the water can impart motion to the vessel. The inability of the condensed particles to achieve kinetic and thermal equilibrium with the gas causes a reduction in I_{sp} .

Recombination Loss

Computer programs have been written to model the complex chemical reactions that take place as propellant is burned. These reaction are dependent on (1) the amounts and types on chemical compounds present, the combustion temperature, and the resident time of the gases within the motor. All chemical reactions, as fast as they may seem to us, take a finite amount of time. In some instances, the gas may be exhausted through the nozzle before all reactions can take place. This results in a loss in performance.

All propellant thermochemistry computer programs assume either (1) **Frozen flow** – a situation in which the reaction rate is much slower than the time the gas is in the motor. The components of the gas are thus “frozen” and are not allowed to react further. (2) **Equilibrium flow** – a condition in which all reactions are assumed to take place instantaneously. Final and complete recombination of all constituents is thus allowed within the motor and nozzle, instantaneously readjusting as the gas flows through the nozzle. Nature actually lies somewhere between (1) and (2).

CHAPTER VII . . . PROPELLANTS

Since our discussion of the ancient Chinese and their "fire arrows", we have scarcely mentioned propellants. Yet, without propellant our rocket wouldn't go very far. This chapter will be devoted to a discussion of solid rocket propellants – desired properties, major ingredients, and manufacturing processes.

Propellant is solid matter, which is physically and chemically stable at ambient temperatures, but which will, once it is ignited, burns smoothly and evolves hot gas continuously without depending on an atmosphere.

Solid propellants usually have a plastic-like, caked appearance and burn on their exposed surfaces to form hot exhaust gases which, in turn, produce a reaction force. A physical mass or body of the propellant is referred to as the grain. Some rockets have more than one grain in the same chamber. A solid propellant contains all the materials necessary for sustaining chemical combustion. It may be a heterogeneous mixture of oxidizing crystals of perchlorate in a matrix of an organic plastic-like fuel such as asphalt or it may be a homogeneous charge of special chemicals such as modified nitrocellulose-type gunpowder.

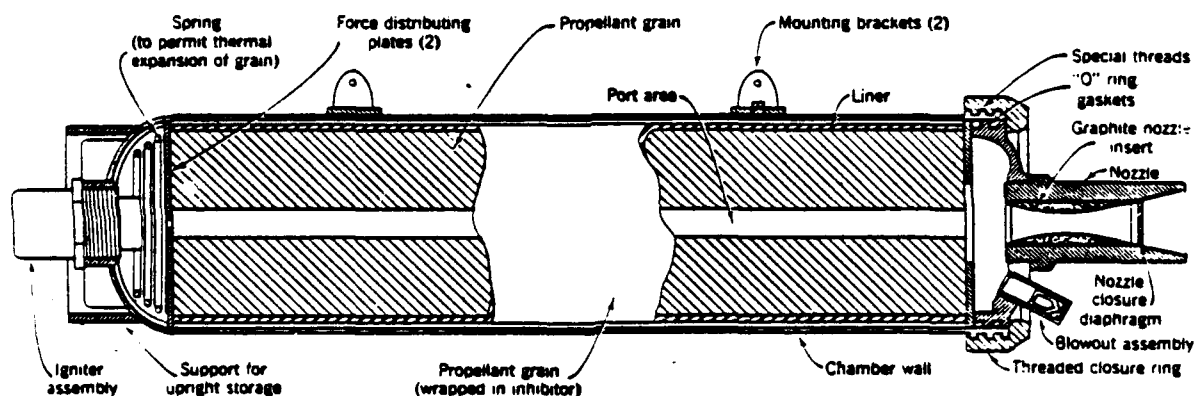

Sectional view of typical solid propellant rocket booster with floating grain.

Once the propellant charge is ignited, a well-designed grain will burn smoothly on its exposed surfaces without severe surges or detonations. The combustion will consume the propellant grain material at a smooth rate in a direction perpendicular to the burning surface.

The shape, size, exposed burning surface, and geometric form of the grain influence the burning characteristics of the rocket and largely determine the propellant mass flow, operating pressure, thrust, and duration. The same propellant (that is, the same chemical formulation) can therefore be made into many different grain configurations.

Any one solid propellant usually includes two or more of the following:

1. Oxidizer (nitrates or perchlorates).
2. Fuel (organic resins or plastics).
3. Chemical compounds combining fuel and oxidizer qualities (nitrocellulose or nitro glycerin)
4. Additives (to control fabrication, process, burning rate, etc.)
5. Inhibitors (bonded, taped, or dip-dried onto propellant) to restrict burning surfaces.

Propellants

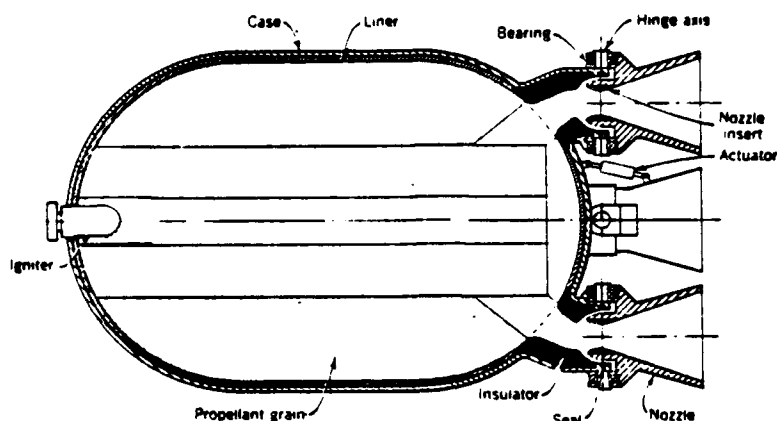

Simplified schematic diagram of typical case-bonded solid propellant rocket with four hinged nozzles.

There are several types of propellants. The first, often called **composite propellant**, has two important ingredients, a fuel and an oxidizer, neither of which would burn satisfactorily without the presence of the other. Often these consist of crystalline, finely ground oxidizers, dispersed in matrix of fuel compound. The second type contains unstable chemical compounds, such as nitrocellulose or nitroglycerin, which are capable of combustion in the absence of all other materials. This type, sometimes called homogeneous propellant, contains no crystals, but uses chemical fuels that contain enough chemically bonded oxidizer material to sustain a combustion. Because many of these propellants are based largely on a colloid of nitroglycerin and nitrocellulose, they are often referred to as **double-base propellants** (this differentiates them from many gun powders which traditionally have been based on one or the other). There are other propellant types such as black powders and types combining some of the ingredients used in the homogeneous and the composite varieties.

Most of the accepted solid propellants contain from four to eight different chemicals. In addition to the principal ingredients (fuel and oxidizer), small percentages of additives are used to control the physical and chemical properties of solid propellant. Additives have been used for the following typical purposes (1) accelerate or decelerate the burning rate (catalyst) (2) increase chemical stability to avoid deterioration during storage (3) control various processing properties of propellant during fabrication (curing time, fluidity for casting, wetting agent, etc.) (4) control heat absorption properties of burning propellant (5) increase physical strength and decrease elastic deformation (6) minimize temperature sensitivity. The table below gives compositions, physical properties, and performance parameters for several types of solid propellants.

Propellants

Propellant Type	Castable Composite		Molded Composites	Extended Double Base	Cast Double Base	Asphalt Base Thermoplastic
	Oxidizer/fuel KClO ₄ /C ₂ H ₄ O ^a	Oxidizer/fuel NH ₄ ClO ₄ /C ₂ H ₄ O ^b				
Propellant system	KClO ₄ (50-80) C ₂ H ₄ O(50-20)	NH ₄ ClO ₄ (50-85) C ₂ H ₄ O(50-15)	Ammonium picrate (AP) Potassium nitrate Fuel	Nitrocellulose (NC) Nitroglycerin (NG) Miscellaneous	Nitrocellulose (NC) Nitroglycerin (NG) Plasticizer (PI) Miscellaneous	Asphalt/perchlorate
Typical ingredient variation, per cent			AP (70-40) KNO ₃ (20-50) C ₂ H ₄ O (10-10) Average about 3200	NC (50-60) NG (30-45) Misc. (1-10) 3800-5200	NC (45-55) NG (25-40) PI (12-22) Misc. (1-2) 2600-4000	Asphalt (22-30) KClO ₄ (78-70)
Adiabatic flame temperature, °F	2800-5000	2800-4500	Average about 30	22-28	22-28	3800-3300
Average molecular weight, lb per mole	25-35	22-25	Average about 30	22-28	22-28	30
Specific heat ratio	1.24-1.27	1.22-1.26	Average about 1.25	1.21-1.25	1.24-1.26	Average 1.25
Typical sea level specific impulse, sec	165-210	175-240	160 to 200	205-210	160-220	180-195
Characteristic velocity, ft/sec	1600-4000	1800-4000	3500-3800	4500-5100	3500-4200	3700-4200
Burning rate at 1000 psi and 70 °F, in/sec	0.5-1.2	0.1-0.5	0.24-1.0	0.6-0.9	0.22-0.37	1.1-1.7
Burning rate exponent, <i>n</i>	1.0-0.7	0.1-0.4	Average about 0.5	0.1-0.8	0.1-0.8	0.7-0.8
Specific weight, lb/in ³	0.06-0.07	0.055-0.063	0.059-0.064	Average 0.058	Average 0.057	0.063
Maximum volume impulse at 1000 psi, ft-sec/in ²	22,500	25,000	19,500	21,500	19,500	21,000
Temperature sensitivity of pressure, per cent	2-0.2	0.4-0.1	0.16-0.3	0.1-0.8	0.1-0.8	Average 1
Lower combustion limit, psi	200-1000	<200	<500	<500	<500	500
Upper pressure limit, psi	>6000	>6000	<3000	>10,000	>5000	10,000
Probable allowable operating temperature limits, °F	-70 to 170	-70 to 170	-40 to 140	-20 to 140	-30 to 140	1-20 to 1120
Storage stability ^c	Good Abundant	Good Much at low oxidizer; little at high oxidizer; mist at relative humidity greater than 60 per cent	Good Abundant	Fair Little	Fair Little	Good Abundant
Smoke						
Mechanical properties	Soft and resilient to hard and tough	Soft and resilient to hard and tough	Hard and brittle	Hard and tough	Hard and tough	Variable with temperature, poor when warm

^a This table is included only as a guide and gives ranges of typical value. Data furnished in part by C. I. Hartley, Grand Central Aircraft Company, and in part by U.S. Naval Ordnance Test Station, China Lake.

^c C₂H₄O is tabulated as typical in per cent composition for many solid propellant fuels.

† Storage stability is rated bad if the propellant cannot be stored indefinitely at temperatures greater than 150°F.

Propellants

Desired Properties

In evaluating and comparing solid propellant properties, the following are considered important and desirable. It is important to distinguish between the properties of the raw materials, the fabricated propellant, and the hot combustion products. The order in which these desirable characteristics are listed below has no relation to their relative importance.

1. A high release of chemical energy promotes a high performance and, therefore, a high value of combustion temperature and specific impulse.
2. A low molecular weight of the combustion products is desirable to increase the value of the specific impulse.
3. The solid propellant should be stable for a long period of time and should not deteriorate chemically or physically during storage.
4. High density of the solid propellant permits the use of a small chamber volume and, therefore, a small chamber weight.
5. The solid propellant should be unaffected by atmospheric conditions; for example, it should not be hygroscopic.
6. The propellant should not be subject to accidental ignition, that is, its auto-ignition temperature should be relatively high and it should be insensitive to impact. For this reason also the lower combustion pressure limit should be higher than atmospheric.
7. The propellant should have high physical strength properties, particularly its tensile, compressive, and shear strength, adhesive qualities, and its modulus of elasticity and elongation.
8. A coefficient of thermal expansion which matches that of the chamber material will minimize the relative motion within the chamber and the thermal stresses within the stored grain.
9. The propellant composition should not require special materials for hardware construction.
10. The propellant should lend itself readily to production and have desirable fabrication properties, such as adequate fluidity during casting, easy control of chemical processes (such as curing), or a minimum of volume change after casting or molding (shrinkage).
11. The propellant's performance properties and fabrication technique should be relatively insensitive to impurities or small processing variations to simplify its production and inspection and reduce its cost.
12. The physical properties and combustion characteristics (burning rate) should be predictable and not be affected appreciably over a wide range of storage and operating temperatures, ideally from -100 to 250°F . This implies that the temperature sensitivity is low.
13. The exhaust gas should be smokeless to avoid deposition of smoke particles at operational locations and to avoid detection in military use.
14. The propellant should lend itself readily to bonding to the metal parts, to the application of inhibitors, to different production techniques, and should be amenable to the use of a simple igniter.
15. The exhaust should be non-luminous (to avoid detection in military applications), non-corrosive, and non-toxic.
16. The method of propellant preparation should be simple and should not require a complex chemical plant installation.
17. The solid propellant's conductivity and specific heat should be such as to control heat transfer to the grain.
18. The propellant grain should be opaque to radiation, to prevent ignition at locations other than the burning surface.

Propellants

19. The propellant should resist erosion and have predictable and repeatable erosive burning characteristics.
20. The propellant grain should withstand repeated temperature cycling prior to operation without physical or chemical deterioration.
21. The propellant raw materials should be cheap, safe and easy to handle or transport.

7.1. Basic Chemicals

The formulation of solid propellants lies within the realm of the chemist who constantly strives to balance desirable and undesirable characteristics of ingredients to maximize the performance while holding costs down.

Oxidizers

None of the oxidizers used today have only desirable properties, in fact every one of them has several serious drawbacks. The list below gives several of the more representative types.

The Perchlorates

All of the perchlorates produce hydrogen chloride (HCl) and other chlorine compounds in their reaction with fuels. Their exhaust gases are not only toxic, but also highly corrosive to many materials. The hydrochloric acid condenses in moist atmospheres to form a dangerous fog. With the exception of ammonium perchlorate and nitronium perchlorate, all form a dense smokey exhaust because KCl or NaCl are white powders. Ammonium and potassium perchlorate are only slightly soluble in water and therefore can be used for propellants which are exposed to moisture. The perchlorates are usually produced by the electrolysis of chlorides which are naturally available materials.

Oxidizer	Available Wt. Per Cent of Oxygen	Specific Gravity
$KClO_4$	46	2.5
NH_4ClO_4	34	1.9
$LiClO_4$	60	2.4
$NaClO_4$	52	2.54
NO_2ClO_4	66	2.25
NH_4NO_3	20	1.9
KNO_3	39.5	2.1
$NaNO_3$	47	2.26

The oxidizing potential of the perchlorates is generally high, and for this reason they are often found in propellants of high specific impulse. The perchlorates are available in the form of small white crystals. Because the crystal size influences the fabrication process and the burning rate, it is necessary to closely control the percentage of the several crystal sizes usually present in the oxidizer. Nitronium perchlorate (NO_2ClO_4) is the most powerful of the perchlorates, but it is very sensitive can be detonated readily. All perchlorate oxidizers are potential explosives. By using special high purity material, special crystals processing techniques, and careful handling, it is possible to formulate high energy propellants with these oxidizers.

Propellants

Inorganic Nitrates

Three nitrates are of interest in solid propellant preparation and are listed in the table above. The first two, potassium nitrate and sodium nitrate, produce undesirable smoke in the exhaust because of the solid material formed in the combustion products. The third, ammonium nitrate, has the big advantage of a smokeless, relatively non-toxic exhaust, but its oxidizing potential is low and it is suitable primarily for low performance, low burning-rate applications. For gas generator propellants, this has considerable merit.

The nitrate salts are used in fertilizers and other industrial applications and are relatively cheap and naturally available. Ammonium nitrate can be produced from nitric acid and ammonia.

Organic Nitrates

These are basically solid monopropellants capable of chemical energy release and they are used as ingredients in homogeneous or double base propellants. Some of the organic nitrates most commonly used in propellants are glycerol trinitrate or nitroglycerin, $\text{CH}_2\text{N}_5(\text{ONO}_2)_3$, diethyleneglycol dinitrate or DEGN, $(\text{CH}_2\text{CH}_2\text{ONO}_2)_2\text{O}$, and cellulose nitrate or nitrocellulose, $\text{C}_6\text{H}_7\text{O}_2(\text{ONO}_2)_3$. The $-\text{ONO}_2$ group is characteristic of nitrates. All are basically unstable compounds which are capable of oxidizing their organic material.

Nitroglycerin is a colorless oily liquid, only slightly soluble in water but readily soluble in alcohol and ether. It is rapidly absorbed through the skin, and undue exposure to this material often causes violent headaches. With a slight shock nitroglycerine can detonate violently. The molecule contains more than sufficient oxygen to convert the carbon and hydrogen to the corresponding oxides, and gaseous nitrogen is liberated. The generally accepted method of production is the nitration of glycerin using a mixture of nitric and sulfuric acids. Nitroglycerin is somewhat less sensitive in the solid form, and also when absorbed in such materials as diatomaceous earth, sawdust, and charcoal. Commercial dynamites usually contain nitroglycerin absorbed in sawdust, in which form it is sufficiently insensitive to shock to permit handling and shipping with comparative safety. A somewhat similar material is obtained when nitrocellulose is gelatinized with nitroglycerin, the resulting material having satisfactory stability. This is the basis of Ballistite type propellants, or so called double base propellants. Commercial nitrocellulose has much the same appearance as ordinary cotton and consists largely of cellulose trinitrate. It is fabricated by the nitration of wood pulp or cotton linters. The degree of nitration influences the properties of nitrocellulose. Highly nitrated material, called guncotton, contains 12.2 to 13.8 percent nitrogen and thus corresponds closely to pure cellulose trinitrate, the theoretical nitrogen content of which is 14.16 percent.

Many different compositions of double base propellants have been used successfully. Additives (5 to 30 percent) are used to aid in the control of physical properties, ease of manufacture, stability during storage, flash suppression, and augmented capacity to prevent ignition by radiation of energy through the translucent grain at locations other than at the burning surface. An increase in nitrocellulose content generally increases the physical strength and a high nitroglycerin content tends to increase the performance and burning rate.

Propellants

Fuels

Many different organic fuels have been used in solid propellants. They are selected in part for their ability to be oxidized, for adding desirable physical properties to the mixtures, and for their desirable fabrication characteristics. In fabrication many fuels are mixed with a crystalline oxidizer while the fuel is in the liquid state and often at an elevated temperature. Thereafter, the fuel undergoes either a chemical change or a physical change (due to a temperature drop between the elevated mixing temperature and ambient temperature) to harden the grain.

Asphalt – Oil Type Fuels

Asphalt is a bituminous hydrocarbon. It needs to be heated and liquefied to permit it to be mixed with the solid oxidizers. The mixture is then cast into rocket chambers and allowed to cool to a semi-solid state. Because asphalt becomes very brittle and has a tendency to crack at low operating temperatures, it has been necessary to mix oils with asphalt to improve the physical characteristics at low temperatures. However, the maximum operating temperature limits of the propellants are narrow because the material with added oil becomes too soft to withstand deformation in storage or operation at the higher temperatures. Several early United States propellants used asphalt as a fuel together with perchlorate oxidizers.

Plastic Fuels

Various thermosetting plastics have been investigated for rocket propellants, including phenolformaldehyde and phenolfurfural resins. The various components of the plastic are mixed, the oxidizer is added, and the mixture is cast before the plastic sets. With non-thermosetting plastics, such as styrene, a soft non-hardening elastic mixture should be retained.

Polyvinyl Chloride

Together with plasticizer, Polyvinyl Chloride (also known as PVC) has been successfully used with ammonium perchlorate or ammonium nitrate oxidizers. In very small particle sizes, it does not react with its plasticizer and it can be mixed readily; when cured at a temperature of 300°F or more it absorbs or dissolves the plasticizer and thus forms the hard matrix of the grain. The high curing temperature causes thermal stresses and shrinkages which limit the size of grains.

Polymers

Many different polymerized organic compounds have been used as the fuel in solid propellants. Here the fuel is chemically transformed by polymerization (which is induced by chemical reagents or cross-linkers and heat) after it has been mixed with its oxidizer and additives. This includes compounds such as various vinylpolyesters, polysulfides, polyurathanes, vinyl pyridines, butadiene polymers, and various types of synthetic rubbers. All of these retain some of their rubbery properties in the grain and, thus, are relatively adaptable to taking internal stresses (usually induced by pressure or by temperature cycling). They form a strong matrix for the grain and take some rugged handling without cracking the grain. They are prepared by the polymerization of monomers which when cross linked form large molecules. These vulcanized organic compounds have been very successful in high performance solid propellants. There is a large variety of these available and there is an infinite number of possible propellant formulations that can result from these fuels.

Propellants

Metallic Fuels

Additives, such as 15 percent aluminum, have been used in composite propellants. The addition of fine aluminum particles seems to help in three ways: it causes the combustion temperature to be higher, thus increasing the specific impulse slightly, it increases the density of the grain and it appears to alleviate certain types of combustion instability. The use of beryllium causes not only an increased combustion temperature, but also a lower molecular weight and thus can increase the theoretical specific impulse by five to ten percent. However, the reaction products containing beryllium are exceedingly toxic and require special safety precautions. Propellants with metallic additives usually contain a condensed phase (liquid or solid) in the exhaust gas; this increases the problems of nozzle material erosion, heat transfer and nozzle material compatibility. It also complicates the prediction of theoretical specific impulse.

7.2 Homogeneous Propellants

Homogeneous propellants are those propellants using nitrocellulose as the basic ingredient in order to give them the structural characteristics of a plastic. This is because nitrocellulose, when properly compounded, forms a colloid which can be processed into many shapes. Whether the compositions contain only nitrocellulose or have nitroglycerin as a second combustible ingredient determines whether these propellants are single- or double-base.

Single-Base Propellants

Single-base propellants contain nitrocellulose as the main ingredient with diphenylamine, or similar compound, as a stabilizer and with other additives depending on the application. These are used primarily in gun applications and cartridge-actuated devices.

Double-Base Propellants

Although Ballistite for guns can (and in Italy for some years did) consist of nothing more than a 50:50 mixture of carefully purified nitrocellulose and nitroglycerin, such a combination is not adequately stable for military use and would not perform well in rockets for numerous reasons. Nevertheless, the U.S. rocket propellant in World War II, JPN (Jet Propulsion/Navy), did consist mainly of nitrocellulose (51 percent) and nitroglycerin (43 percent) and it was based on long-used gun propellants. A fuel-type plasticizer, new stabilizer, a wax, a blackening agent, and a potassium salt were used in minor proportions to improve processing, storability, and combustion properties respectively, but all the energy, or specific impulse (I_{sp}), was derived from the nitrocellulose and nitroglycerin. In other words, all necessary minor ingredients detracted from the basic ballistic performance or I_{sp} . The JPN Ballistite served the U.S. for almost all military rocket needs during World War II in spite of its far-from-ideal internal ballistic properties.

Currently, double-base propellants have two principal ingredients— nitrocellulose and nitroglycerin and certain additives such as the following:

- (1) Plasticizers – phthalates, triacetin
- (2) Stabilizers – 2-nitrodiphenylamine, tertiary butylcatechol, ethylcentralite, N-methyl, p-nitroaniline
- (3) Burning-rate modifiers – lead salts, copper salts
- (4) Extrusion lubricants – stearates, soaps, waxes
- (5) Flash suppressors – potassium salts.

Propellants

Recently, additional oxidizers have been added, such as ammonium perchlorate and HMX, which make a modified type of double-base propellant, termed "composite-modified double-base". Aluminum is also becoming more commonly included to increase energy and to stabilize combustion.

Cast Double-Base Propellants (CDB)

This type of propellant was developed to eliminate the size and shape limitations of extruded propellants. The mold, or chamber, is filled with casting powder (single-base or double-base powder) and then the chamber is "cast", i.e. filled, with nitroglycerin casting solvent (nitroglycerin, plasticizer, and stabilizer). The advantages that apply to the extruded double-base propellants also apply to the cast double-base propellants. However, the cast double-base propellants have no size or shape limitation and the heat effects during curing are small since no chemical reactions are involved. Excluding the size and shape limitations, the disadvantages of the cast double-base propellants are the same as those for the extruded double-base propellants.

Double-Base Processing

Double-base propellant grains are prepared by a solvent or a solventless extrusion process, or sometimes by a casting process. In the solvent process a volatile solvent is mixed with the ingredients to improve the mixing, casting, extrusion, and forming qualities. Resulting grains are dried to remove the solvent. However, the solvent may, by evaporation, cause fissures, shrinkage, and cracks. This process is desirable for propellant grain configurations with thin sections. In the solventless process the blending and mixing are accomplished largely by running the propellant through heated rollers or other mechanical shaping devices.

The material is then generally extruded through a suitable die at very high pressures (on the order of 5000 to 20,000 psi). The extruded grain is generally heated to relieve internal stresses in the material. Although the extrusion process requires costly equipment, it permits the exact control of grain size and shape. In the casting process of double-base propellant, nitroglycerin liquid with additives, is cast into an evacuated mold which has been preloaded with small pellets of nitrocellulose and forms a nearly homogeneous solid with liquid mixture. This process is relatively non-hazardous and permits the manufacture of very large grains.

Casting Powder Manufacture

Casting powder granules are small solid cylinders (approximately 0.050 x 0.050 inch). To prepare the propellant paste or dough, alcohol-wet nitrocellulose is placed in a mixer. The desensitized NG and other ingredients are added, and the mixing is continued until the proper consistency has been achieved. The dough is then placed in sealed cans and transported to the blocking press where it is shaped into convenient sizes for loading into the finishing press. The blocks are loaded in the press and the strands are extruded through a die assembly containing many small holes. Each strand emerges from the press into a Teflon tube which directs the strand to a small can where it is collected. The cans are then transported to the cutting rooms where the strands are fed between two scored rollers to a wheel of rotating blades which cut the strands into individual casting powder grains or granules. The casting powder is then placed on trays and taken to drying rooms for removal of excess volatiles.

Propellants

Cast Propellant Grain Manufacture

The next general procedure in the cast double-base process is the combining of the casting powder with casting solvent (nitroglycerin, inert plasticizer, and stabilizer).

The first step is the preparation of a tube or chamber that will serve as the mold for the cast propellant. Tubes (generally called beakers) made of cellulose acetate film require no special surface preparation since the cast propellants will adhere to this material. However, if a phenolic tube or a Fiberglas/epoxy resin chamber is used, certain materials are applied to the inner wall to present a surface that will permit a firm bond to form between the propellant and the tube.

The loaded mold (filled with casting powder only) is removed to a building for evacuation. Application of vacuum removes the surface moisture and adsorbed air from the casting powder. Removal of water and adsorbed air at this stage promotes better casting and more desired physical properties.

Addition of the casting solvent is considered to be the actual casting step. This liquid phase is composed generally of approximately 75 percent nitroglycerin, an inert plasticizer, such as triacetin, and a stabilizer such as 2-nitrodiphenylamine. These ingredients (previously well-mixed) have been held under vacuum to remove air and moisture to below 0.10 percent water. The casting solvent is handled and transported in a special container called a desiccator. This vessel is discharged by the application of nitrogen or air pressure into the mold which contains the casting powder. Casting can be accomplished either from the top or the bottom of the mold and with or without the use of vacuum.

The driving force necessary to coalesce the solid (casting powder) with liquid (casting solvent) is supplied by heat in a curing bay. Elevated temperatures (100° F, exact level varying with the application) hasten the migration of the plasticizers into the solid phase, and after a period of time (2 to 10 days) the mass is solid and reasonably homogeneous. Some units are cured under pressure (piston pressurized with an inert gas) in order to ensure better homogeneity and density in the structure. The length of time and temperature of the cure are controlled in order to obtain optimum physical properties.

Grains cast in beakers are usually cut to the proper length by a remotely controlled saw. They may also be sectioned for various tests with the use of the same machinery. Various types of coolants are used to aid in sawing and machining as a means of removing the fine particles of propellant as well as for keeping the temperature below the ignition point.

Inspection of the grains consists of measurements for dimensions, visual appearance, and X-ray. This last method serves as a means of internal inspection of the propellant and allows the propellant-to-liner bond to be examined. Separations can sometimes be repaired by filling the crack with a plastic compound. Techniques and compounds have been developed to carry out this work with a considerable degree of success.

Solventless Extrusion Process

One of the oldest processes for the manufacture of propellants is the extrusion method. The mixed material is forced through a die that forms propellant grains of the desired shape.

In the manufacture of small rocket and gas-generator grains, the solventless process is used. This method, as the name implies, does not use solvents such as ether, alcohol, and acetone. Most of the propellant made by this process in the form of "carpet rolls".

Propellants

Preparation of carpet rolls for the extrusion press requires an intimate mixture of all components. The figure below shows the process. All materials not adversely affected by water are added to warm water in a large tank and vigorously stirred. The slurry is dewatered on a filter and put into bags. These are aged for 48 hours or longer so that proper diffusion of the plasticizer can take place. After aging, the paste is dried at an elevated temperature until the moisture content is about 10 percent. Water-soluble materials are then blended with the dried paste in a suitable mixer.

Conversion of the loose granular material from the slurry mixing to a suitable material for press feeding is accomplished on rolling mills. The paste is put first on the differential mill by remote means. The rolls are heated by hot water or steam and rotated at different speeds. Pressure and heat working of the material produce a consolidated sheet that sticks to the faster roll. A cutter, remotely operated, removes the sheet from the roll. Generally, three such sheets are combined, sent to the even-speed mill where they are consolidated, folded in two or more directions and run through several times to remove air streaks. This mill is also heated, but is operated at a lower temperature and slower speed than the differential mill. Material coming from this operation is in the form of long sheets having the desired surface finish and thickness. The even-speed sheets are cut lengthwise into 4-inch-wide strips by a slit and made up into carpet rolls. These are sized a little smaller than the extrusion presses that are to receive them.

In order to extrude the carpet rolls, it is necessary to heat the propellant, generally in the range of 100–160 °F. The press is also heated to about the same temperature. Several rolls of powder are loaded into the press, air is removed by vacuum, and then the roll is extruded into grains by ram pressure of 5,000 to 10,000 psi.

Further processing depends on the end use of the grain. Such operations include annealing, machining, inhibiting, and others. The production rates are large and have been economical on units up to about 12 inches in diameter.

The U.S. has a huge war time capacity for propellant of this type, most of it built by 1945, and maintained by Government contractors in a standby condition. A large portion of this capacity was utilized during World War II and during the Korean and Southeast Asian conflicts. Over 60 million grains of just one type have been produced for 2.75-inch folding-fin rockets in these plants since 1952. Virtually no commercial capacity exists for solventless propellant in the U.S. and even foreign governments have tended to own or control closely their national production of such materials.

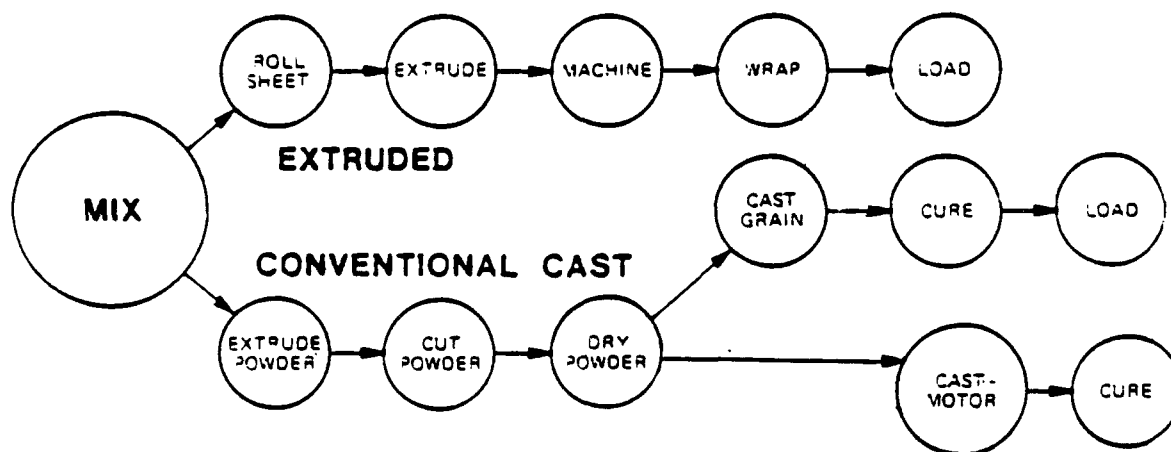

Propellants

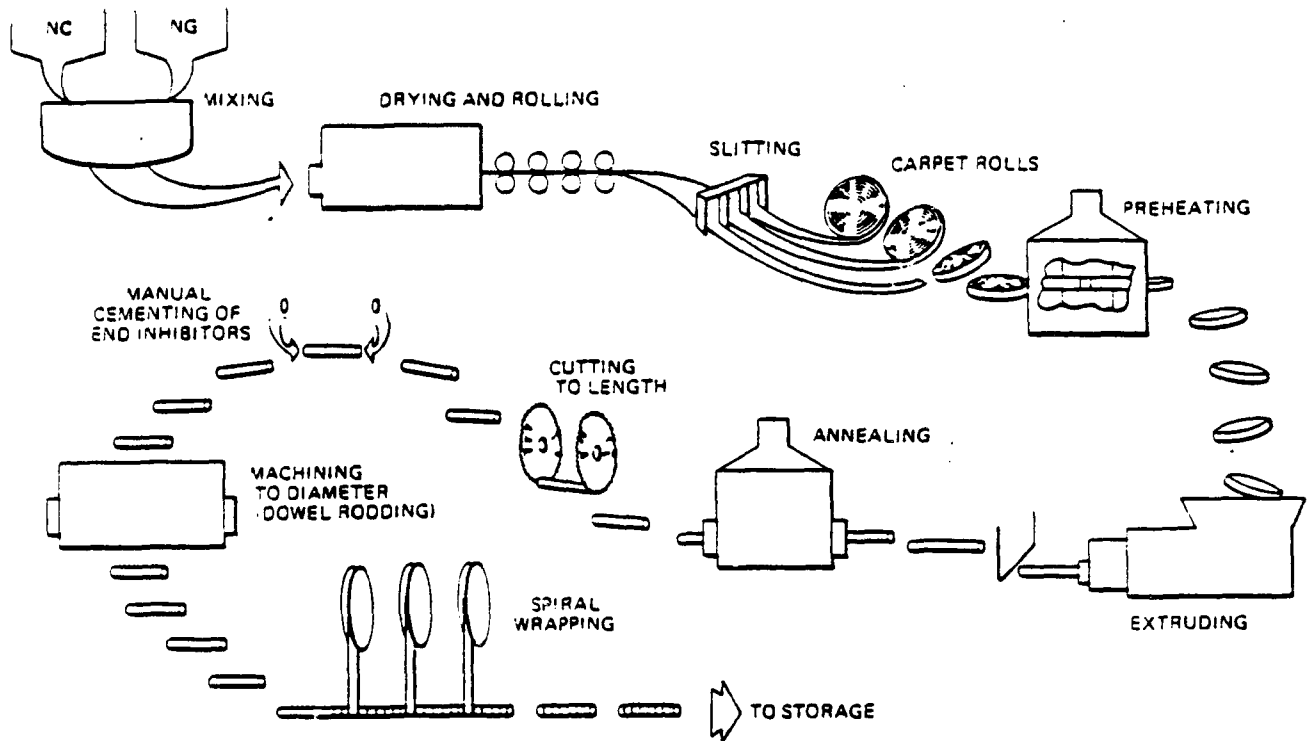

SOLVENTLESS EXTRUDED PROPELLANT PROCESS

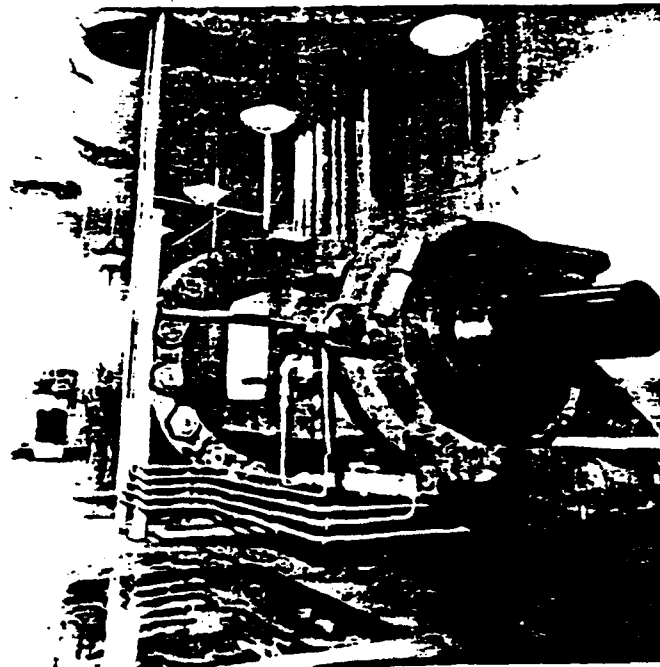

Very large extrusion press used by Phillips Petroleum for the production of ammonium nitrate tubular grains for the JATO 16-NS-100-M15

Propellants

7.3 Nonhomogeneous (Composite) Propellants

Composite propellants are composed of two principal ingredients – a fuel and an oxidizer—neither of which would burn satisfactorily without the presence of the other. The fuel can be the binder (the rubber- or plastic-based material used to form the solid matrix) or a combination of binder and aluminum powder.

The solids content of propellants range between 70 and 90 percent, the higher limit being controlled by processibility. Ammonium perchlorate is the preferred oxidizer and is the highest percentage of the composition ranging up to 85 percent. For special formulations, ammonium nitrate or other oxidizers are used. Aluminum powder is the most frequently used solid-metal fuel. It is used to increase specific impulse in ranges up to 25 percent of the formulations. Early composite propellants used asphalt-based binders but requirements for dimensional stability, increased strain capability, and higher ballistic performance resulted in the use of polymerizable liquids which would convert into a rigid matrix after curing or polymerization. Some binder families are polyesters, polystyrenes, acrylates, polysulfides, polyurethanes, and polybutadienes. Some rubbers such as butyl and polyisoprene are used as binders in special cases and usually result in extrudable systems instead of castable systems. Polyvinyl chloride is used as a binder but curing takes place as a plasticization and not as a chemical reaction as with other binders. Most development work is now directed toward the use of polymers cured with epoxides or imines and isocyanates, respectively. Plasticizers are usually added to the formation to improve processibility by lowering viscosity and to improve low-temperature properties. Some plasticizers are isodecyl pelargonate, dioctyl adipate, and dioctyl sebacate.

Other additives are required in some formulations to improve processing and aging, and to control ballistics. These additives include antifoam agents, antioxidants, metal oxides or chelates and cure accelerators. Some of the individual additives are as follows:

- (1) Stabilizers – phenyl-naphthylamine, magnesium oxide.
- (2) Processing aids – lecithin, silicone oils.
- (3) Ballistic modifiers – dyes, metal wires, carbon black, metal oxides.

Of recent interest are bonding agents, which are materials that bond the oxidizer crystals into the propellant matrix to allow better mechanical properties at higher solids loading.

Composite propellants offer the following advantages: cost of processing in large motors is relatively low, higher energy oxidizers give higher specific impulse, cartridge loading or case-bonded systems are possible, and burning rates are unaffected by high accelerations. On the other hand they offer the following problems: mechanical properties are very different from double-base formulations but allow case bonding, energy is limited by solids loading limitations; moisture usually must be excluded during processing and storing; casting is complicated by gassing and high viscosity, they are smokey in humid atmospheres, and their exhaust is corrosive and, hence, somewhat more toxic than that of double-base.

A feature of ammonium perchlorate, rubber-based, composite propellants is a natural tendency toward low pressure exponent (“n” in the burning rate equation). True plateau burning is seldom achieved in high performance composite systems, but slopes (“n”) of 0.3 or 0.4 are very common and are adequate to ensure operability over a wide range of temperatures. In general burning rate increases with the oxidizer content, together with specific impulse and density, but for the same composition it can be adapted within fairly wide limits by the choice of oxidizer particle size and mixing time, and by adding suitable catalysts.

Propellants

For instance, for the same composition (oxidizer 75 percent, fuel 25 percent) it is possible to increase the burning rate from 0.2 to 0.45 in/sec by varying the particle mean diameter from coarse (150 μ) to fine (25 μ). However, very large particles may not burn completely in the chamber. Catalysts like manganese dioxide, ferric oxide, copper chromite, or many others (Cr_2O_3 , SnO_2 , TiO_2 , ZnO) are also used for increasing r_b . They can also act as radiation-absorbing materials.

A twenty-year, multimillion-dollar effort on binders for ammonium perchlorate oxidizer, aluminum fuel, and energetic gas producers, such as nitroguanidine and HMX, has produced an array of composite propellants that provide the base for most of our present-day guided missiles. Most composite-filled missiles use a polybutadiene as the propellant binder. However, polyglycol-based polyurethanes, polyvinyl chloride, polysulfide, and even nitrocellulose binders are still in the inventories.

Because of the need for maximum volumetric loading, it is customary for composite propellants to be bonded to the inside wall of the rocket chamber. Such a practice is not common with most double-base propellants for a variety of reasons, including cost. In a guided missile, propulsion cost is generally a small fraction of total system cost, especially in proportion to its relatively high weight and volume, so that the added expense of case bonding the propellant by means of an intermediate rubbery liner is almost always justified to obtain maximum volumetric efficiency. It is this normally accepted requirement for case bonding that has justified such an enormous effort in developing binders and liners for composite propellants. It is indeed a major accomplishment for a modern composite propellant, which consists of 85 to 90 percent granular solids (typically ammonium perchlorate, aluminum and burning rate modifiers) and only 10 to 15 percent rubbery binder, to perform properly from -65 degrees to +165 degrees F, after being subjected to the rigors of vibration and temperature cycling. The propellant is under stress at all times yet must not develop cracks, large voids, or unbonded regions at any location, at any time in its useful life. This single requirement for perfect structural integrity forms the principal basis for much of the difficult effort in developing composite propellants. Such stringent requirements for explosives do not exist, and requirements for cartridge-loaded propellant grains place a less severe demand on mechanical properties.

Complex minor ingredients for composite propellants include the following:

- (1) Crosslinking chemicals, which have been assigned various names and acronyms, such as epoxies, MAPO (a trifunctional aziridiny phosphine oxide), MT-4, various isocyanates, such as TDI, HDI, IPDI, and polyols such as trimethylol propane
- (2) Burning rate catalysts, such as copper chromite (or chromate), ferrocene, and several less migratory derivatives of this organic iron compound.
- (3) A variety of processing aids to improve the wetting and adhesion between binders and filler
- (4) Anticaking agents for the AP such as tricalcium phosphate.

As mentioned previously, the potential interaction of all these ingredients in the propellants must be determined, fully understood, and rechecked for each new source, if not for each new lot of each material. When the number of ingredients exceeds 15, the potential for variable interaction of these ingredients is truly staggering and has caused problems in manufacture, storage, and use of the propellant.

Not all composite propellants are complex, however. The system used for first stages of Minuteman, Poseidon, and Titan III is a four-ingredient composition of AP, aluminum, PBAN binder, and an epoxy resin curative. Although the PBAN binder has encountered some problems of quality control, these have been largely resolved by the various manufacturers. Unfortunately, the epoxy-

Propellants

cured PBAN binder is suitable for a relatively limited range of environmental temperatures and cannot be used in case-bonded propellants for typical air-launched missiles.

Composite Processing

Propellant formulations which include a crystalline oxidizer in a fuel matrix usually are a liquid mixture at some stage of the fabrication process. They are usually cast and require the following types of processing steps.

Grinding Of Oxidizer Crystals

It has been found that the particle size of the crystal has a major effect on the burning rate, the processing properties, and the physical properties of the propellant. In general, a decrease in particle size results in an increase in burning rate. The effects of crystal size are sometimes so significant that a whole series of propellants can be made with the same composition by merely varying the particle size. The grinding of the crystals to the proper sizes (and also the proper distribution of particle sizes) under controlled atmosphere conditions is a mechanical process which is often difficult to control. A typical experimental grinder is shown on the next page.

The maximum solids loading of a binder can be obtained by choosing a combination of the three ammonium perchlorate sizes that gives the highest bulk density or packing fraction.

Propellant Mixing

The proper proportions of crystalline oxidizer, fuel, and additives have to be accurately measured and the ingredients mixed thoroughly in a suitable piece of equipment. Batch mixing can be accomplished by mechanical methods, for example, by rotating blades in a mixing vessel. Several different continuous flow mixing processes with accurate quality control have been developed.

Propellants

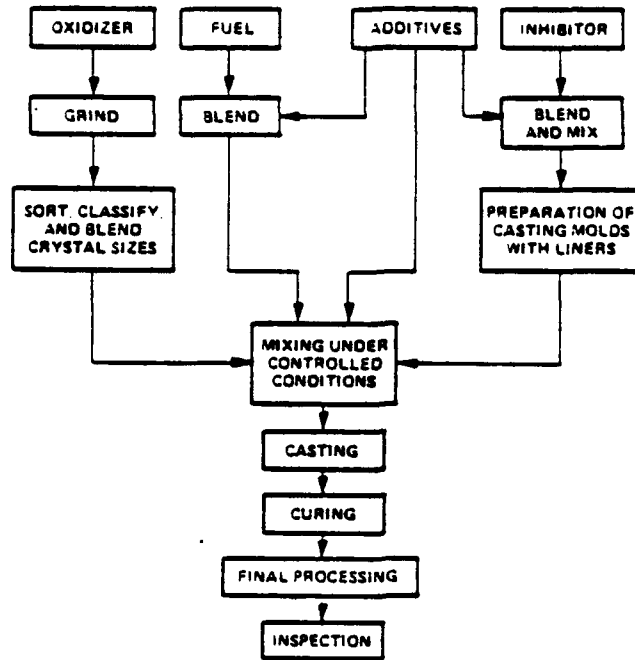

FLOW DIAGRAM OF TYPICAL COMPOSITE SYSTEM PROCESS

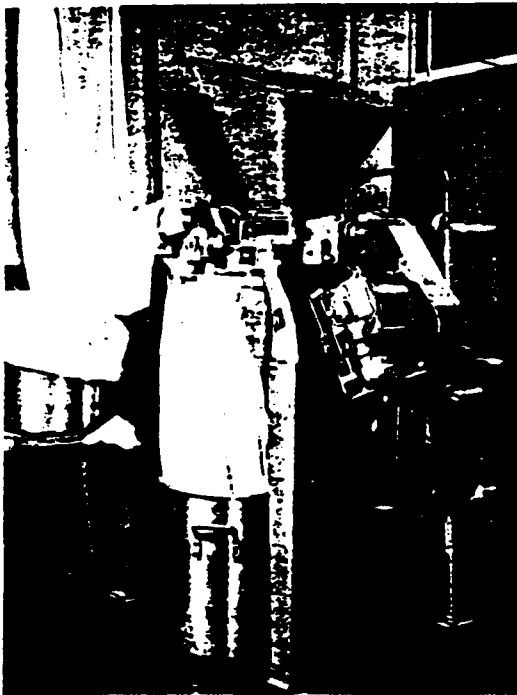

This grinder is used for grinding small quantities of oxidizer crystals to their sized size. Raw material is fed into hopper on top and products are put into buckets derneath machine. Cloth hoses are used to prevent loss of fine crystals. (Courtesy Rocketdyne, a division of North American Aviation, Inc.)



The mixing and blending of crystals of different sizes and other solid ingredients are accomplished in blenders like this one, which is used for experimental batches. The V-shaped tank container is filled through the openings on top of the V and emptied through the valve on the bottom. Blending is accomplished by slow rotation of the unit. (Courtesy Rocketdyne, a division of North American Aviation, Inc.)

Propellants

Some fuels require elevated temperatures (for example, the use of steam-jacketed mixers) to attain sufficient fluidity to permit mixing. Other fuels (usually consisting of two or more basic ingredients) undergo a chemical change and release heat (for example, certain types of polymerizing plastics) to form the grain. With this last type of fuel, the grains must be cast, extruded, or formed within a prescribed time after mixing. If this chemical reaction is highly exothermic, the mixer may have to include cooling provisions.

Most composite propellant mixing is done now in vertical mixers manufactured by the same companies that furnish horizontal mixers for double-base manufacture and for bread dough mixing. The vertical mixer is widely used because (1) its design allows for easy vacuum mixing provisions. (2) the jacketed stainless steel mix cans are removable from the mixer and (3) the steel mix cans are used interchangeably as casting and premix containers.



Large mixer. (Courtesy of Missiles and Rockets).

Most of the mixers in operation today have internal fire protection in the mixer bowl and bowl drop provisions in case of fire or pressure rise.

A mix is started by placing the binder liquids (with the exception of the curing agent) in the mixer bowl and mixing under vacuum at elevated temperature to remove dissolved gases which could cause voids or porosity in the cured propellant. The next step is to add the metal fuels and other additives and again mix under vacuum. The blended preheated oxidizer is then added and mixed. Vacuum is used as soon as all oxidizers have been wetted by the binder, and mixing is continued until a homogeneous mixture is obtained. The curing agent is then added to the propellant and the mix is completed under vacuum. The mixer bowl is removed from the mixer and assembled for casting by placing a pressure plate on the surface of the propellant is cast directly into rocket motor cases.

Casting

In most applications, the propellant is bonded to the wall of the motor case or in insulators through the use of an intermediate layer called a **liner**. **Insulators** are placed in areas that are exposed to the flame front during firing and are made of materials that char and radiate heat when exposed to high temperature. These are usually phenolic or rubber materials filled with silica, asbestos, or Fiberglass. Insulators must be dried to remove substances, such as water, that may interfere with liner cure and prevent a strong bond between the liner and insulator and propellant and liner. Liners are selected which give a chemical bond to the propellant and are usually of the same type polymer as the propellant binder. Liners are castable-curable compositions that are spun, sprayed, or painted on the wall of the chamber. To provide heat resistance, liners may be filled with such materials as ferric oxide or titanium dioxide. Because propellants must adhere strongly to the liners, the best system is one in which the propellant-liner bond strength exceeds the cohesive strength of the propellant.

Propellants

To form the required port area a metal core or mandrel is inserted into the case. This core is usually slightly tapered to permit easy withdrawal after hardening of the propellant. The mandrel is usually coated with some special chemical to prevent the cast propellant from sticking to it.

In the casting area, the mixer bowl is connected to the motor case through the use of manifold valves and sight glasses. Gas pressure is applied in the mixer bowl in the volume between the bowl cover and the pressure plate. When the bottom discharge valve is opened, the propellant flows through the manifold, through a slit plate for deaeration, and into the motor case. The motor case is under vacuum which removes air from the mix as it flows through the slit plate. The motor case may be vibrated during casting but care must be taken to prevent settling of the solids.

Curing

After casting, the propellant is cured. With some fuels, this involves merely a slow and controlled cooling process; with others, it involves a chemical reaction in the propellant. The time required for this chemical process depends on the curing temperature – the higher the temperature the faster the curing. Because the curing is often characterized by an exothermic reaction, the center of the propellant grain may be hotter than the outside.

Final Processing

Final processing includes the withdrawal of mandrels and the sealing of the chamber.

The techniques used for mixing and curing are largely dependent on the fuel nature. With thermoplastic fuels like polyvinyl, the mixing process must take place at fairly elevated temperature (steam-jacketed mixer) and curing involves a controlled cooling process to avoid thermal stresses which cause cracks or pull away from the mold. With cured polymers, the fuel is initially in liquid form at normal room temperature and polymerization is obtained by means of a suitable catalyst added during mixing. Once the catalyst has been included, the propellant must be cast within a prescribed time called "pot-life", before it solidifies (a pot-life between 2 and 24 hours is generally desired). The polymerization can be accelerated by curing at a fairly elevated temperature (up to 100°C; the higher the temperature, the faster the curing) but in some cases significant polymerization may already have taken place at room temperature within the mixer. Case-bonded grains must be cured near room temperature to minimize the thermal stresses due to the differential expansion between the chamber and the grain. Polymerization can be a highly exothermic process requiring an accurate temperature control and even cooling provisions (the center of the grain must not become much hotter than its periphery) and gaseous or liquid reaction by-products must sometimes be avoided. Moreover, low shrinkage during cure is desirable.

Comparison of Propellant Potential

For volume-limited, air-launched missiles, which must function over a very broad spectrum of temperatures, vibration and shock loading, only the best polybutadiene-base, case-bonded composite propellants are presently feasible. Cartridge-loaded, double-base charges are severely deficient for such applications. Case-bonded, composite-modified, double-base charges are deficient in safety aspects, storability, temperature coefficient of ballistic performance, and mechanical properties at extreme low and high temperatures. Nevertheless, each of these systems has its applications and is not, therefore, really competitive with the others. The table on the next page provides basic information about the properties, capabilities, and limitations of each propellant.

Propellants

STATE-OF-RT PROPERTIES OF DOUBLE-BASE AND COMPOSITE PROPELLANTS

Properties	Extruded D.B.	Conv. Cast D.B.	PBAN and CTPB	HTPB	CMDB
Deliverable isp, sea level, at P _c noted (sec)	230 for MKK0 psi, smokeless 230 for 1800 psi with aluminum	220 for 1200 psi low smoke 225 for 1200 psi with aluminum	240 for 1000 psi no aluminum 247 for 1000 with aluminum	243 for 1000 no aluminum 252 for 1000 with aluminum	250 to 262 for 1000 psi
Density, lb/in ³	0.058 to 0.060	0.057 to 0.059	0.060 to 0.064	0.060 to 0.065	0.065 to 0.068
Motor performance index, (sec.)	120 to 160 (This parameter is only partially propellant dependent and is extremely cost related).	115 to 155	150 to 200	155 to 205	160 to 220
$\bar{w}k$ (%/°F)	Zero to 0.15	Zero to 0.15	0.1 to 0.2	0.1 to 0.3	0.3 to 0.5
Pressure exponent	Zero or negative	Zero to 0.3	0.3 to 0.45	0.3 to 0.45	0.4 to 0.65
Exhaust characteristics	Non-corrosive virtually smokeless except when Al is used or components pyrolyze	Non-corrosive low smoke except from components or aluminum	Corrosive secondary smoke from HCl + H ₂ O; primary from aluminum	Corrosive secondary smoke from HCl + H ₂ O; primary from aluminum	Moderate to heavy pit- ting. (Some smokeless are available)
Qualified suppliers	NOS and Army GOC's	NOS, Hercules, and Radford AAP	Ten companies, plus NOSH	Ten companies and NOSH	Hercules, Hunkel, NOSH
Size limitations	12 in. O.D. in thin webs	None; 30 in. O.D. proven	None; (PBAN 240 in. O.D.)	None foreseen	None; 72 in. O.D. proven
Utility in rockets	Excellent, low cost up to 6-in. O.D.	8 in. and larger cart- ridge loaded, widely used.	Excellent in any size; low cost, large. High cost, small. No serious temperature limits	Same as CTPB	Somewhat restrict- ed on temp. range
Safety in mfg	Good	Fair	Good	Good	Fair, but es- tablished hazards
Safety in use and storage	Good to excellent	Good	Very good to ex- cellent	Same as CTPB	Fair, but a known hazard
Mechanical prop- erties	Adequate for cart- ridge loading and firing from -40° to +140°F or better	Adequate for cartridge loading and firing from 0°F to +140°F	PBAN usable from -20° to +165°F, CTPB usable from -65° to +165°F	Usable from -65° to +165°F	Excellent from -40° to +140°F Fair to poor outside this range
Cost	Low in small sizes, large production. High in Astroc size motor (12 in. O.D.)	Moderate in large sizes. High in small sizes	Low (PBAN) in large motors. Moderate (CTPB) in large or med- ium size motors. High cost in small sizes	Moderate, similar to CTPB	High in any diameter

Propellants

7.4 Burning Rate Determination

We've learned so far that burn rate, r_b , is a function of pressure and propellant temperature. But how do we determine what the burn rate vs pressure curve looks like? Several experimental tools have been developed to measure burning rate of solid propellant. Most are based on a very simple idea:

If you have a piece of propellant in a pressurized vessel and measure the time for the grain to burn back a pre-determined amount, you know a single point on the r_b vs P_c curve. Repeat the test at enough different pressures and you can completely define the burn rate curve. The simplest tool for making these measurements is the strand burner or Crawford bomb.

In this vessel, in which the pressure can be pre-set, a strand of propellant is burned like a cigarette. Often a gas, mostly N_2 , which does not influence the propellant burning, ventilates the vessel. The propellant strand is inhibited such that burning will only take place in the longitudinal direction. Two electrical wires are fixed to the strand at a mutual distance L . The melting of those two wires will start and stop, respectively, a chronometer. From the time measured and the distance, L , the average burning rate is determined. By repeating this procedure at different pressures and temperatures, one obtains $r_b(p, T)$.

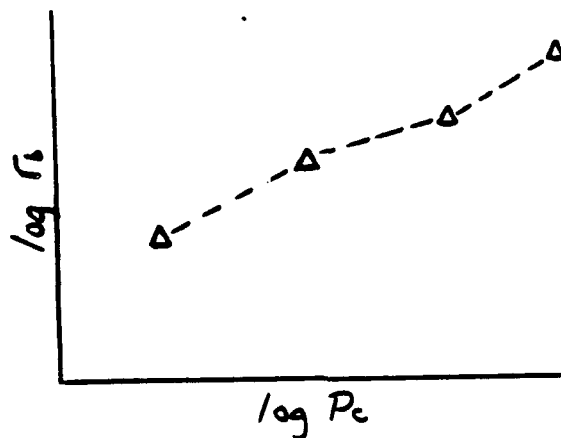
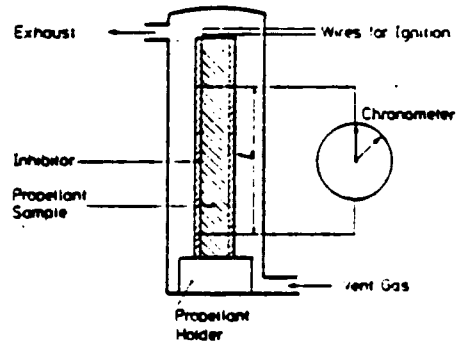

Propellants

As you can see, determination of r_b vs P_c can be fairly time consuming and expensive since only one pressure-rate point is found from each test. To make matters worse, usually 3-5 tests are made at each pressure to allow for test-to-test variations.

If there are breaks or changes in slope for the curve, the test pressures must be properly selected to highlight (and properly identify) the breaks. This is a hit-or-miss process at best

A test burner has been developed which corrects all the above deficiencies of the popular strand burner. The "slab burner" allows the complete burning rate curve to be determined in a single test. Here's how.

The slab burner is a vented pressure vessel (actually a rocket motor) which contains a "brick of propellant approximately 1" thick x 2.5" wide x 6" long. This brick is allowed to burn on all sides producing a surface area that decreases as the brick burns.

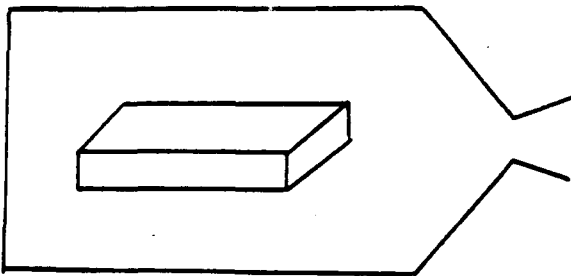

The brick is carefully measured before the test, so its theoretical surface history can be accurately determined. Recalling that motor pressure is proportional to surface area, it should come as no surprise to learn that the pressure-time history of the slab burner is highly regressive (decreases with time).

Instrumentation on the slab motor records pressure every 1/1000 second. At each time point, a computer solves equations similar to those we developed for transient operation. The solution basically answers the question "If I have this surface area, what burn rate must I have had to get this pressure?" A typical pressure range for a test is from 2000 psi to 300 psi and the generated burn rate curve will cover this same range.

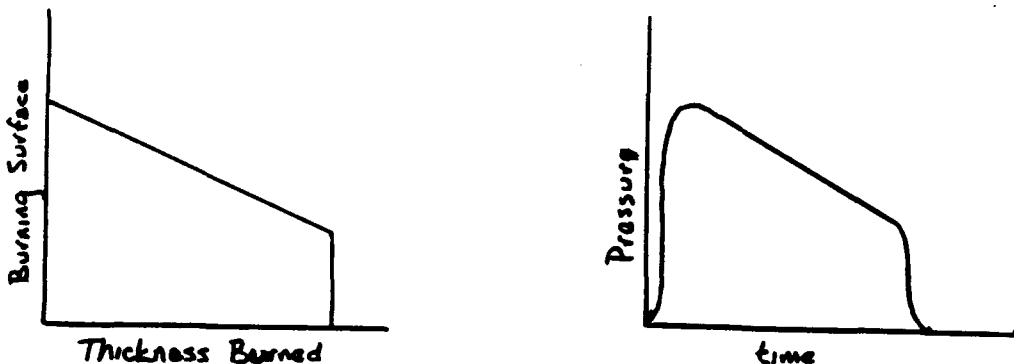

Shown on the following pages is an actual pressure trace and computer printout from a slab burner test. A calculated burning rate history is also shown. Each dot represents a single time point. As you can see, even subtle changes in the burn rate exponent (slope) are made apparent. All this information from a single test!

Other burning rate determination devices used by the propulsion community may be lumped under the generic heading of "subscale motors". These burners try to bridge the scale gap between the strand burner and full scale motors. They contain between 1 and 20 pounds of propellant and are configured such that the pressure remains relatively constant during the burn. By knowing the thickness of the grain and the burn time of the motor, the average burn rate can be determined. As with the strand burner, only a single rate-pressure point is obtained per test.

Propellants

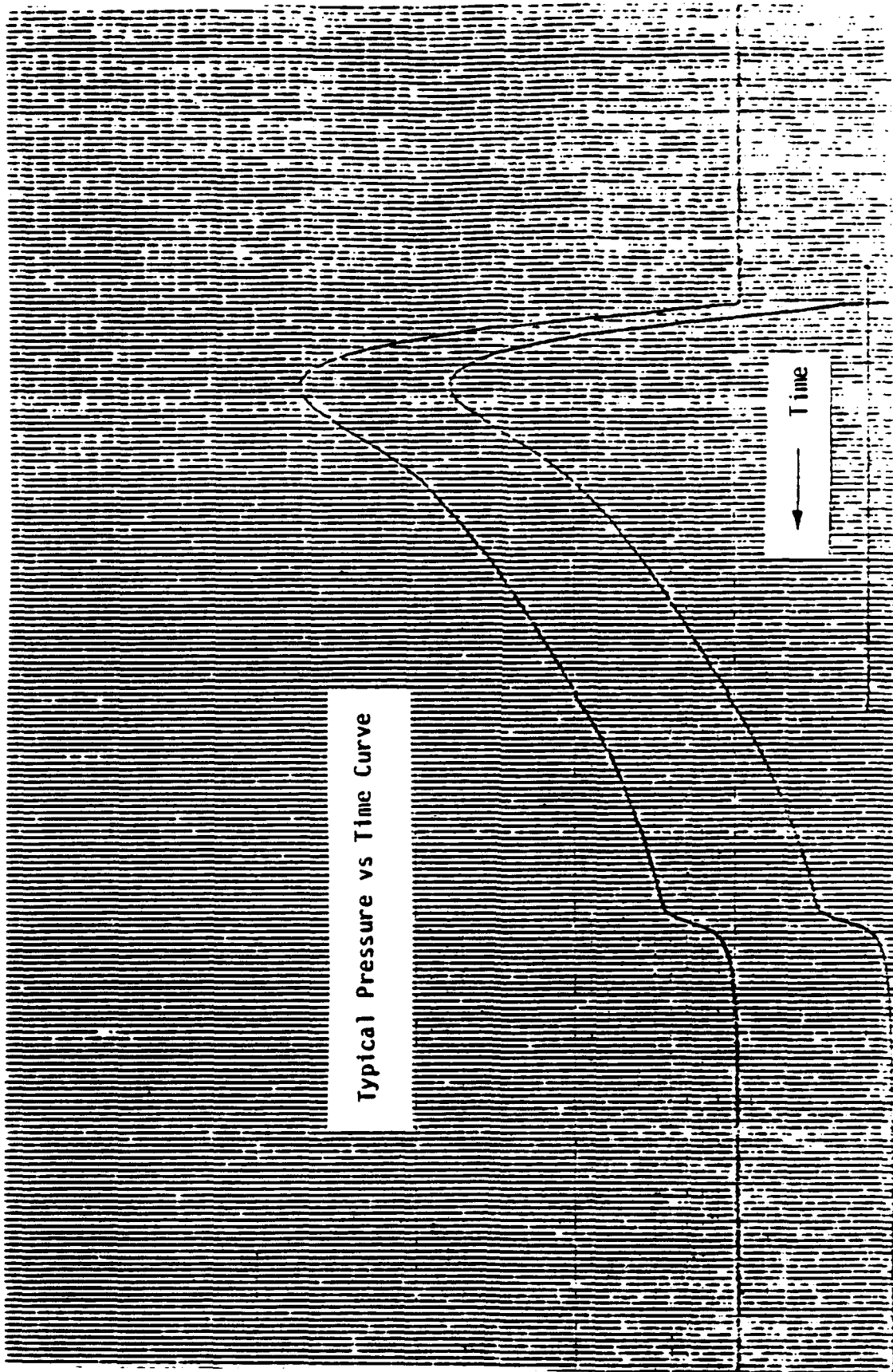

Typical Pressure vs Time Curve

Propellants

TEST # 5301 05/18/77

PAGE 3

ORSEP PROGRAM RUN 5:02 PM THU. 10 MAY. 1980

TIME (SEC)	PRESSURE (PSIA)	RATE (IN/SEC)	VOLUME (CUIN)	DP/DOT (PSI/SEC)	THROAT (CUIN)	SURFACE (SQIN)	THRUST (LBF)	BURNED (IN)	CONSUMED (L)	PTI (PSI-DI)	IMPULSE (LBF-SEC)	(1/2)
.074000	821	.1528	1.5629	57404	.086	48.884	110	.000	.8	0	0	1.55700
.079413	1000	.1844	1.5618	57400	.086	48.888	137	.001	.2	3	0	1.57743
.085000	1692	.3376	1.7596	45801	.086	47.786	270	.005	1.5	21	4	1.73174
.099406	2000	.3571	1.9290	43307	.086	47.613	293	.006	1.9	34	5	1.70779
.115000	2613	.4841	2.1638	31023	.086	47.074	329	.013	4.1	72	10	1.73532
.131189	3000	.5628	2.5367	19787	.086	46.471	451	.021	6.6	115	17	1.74675
.135000	3094	.5638	2.6651	19180	.086	46.262	466	.024	7.4	130	19	1.74787
.150000	3361	.6473	3.2312	9433	.086	45.335	510	.036	11.1	194	29	1.75013
.170000	3497	.6907	3.9330	4716	.087	44.337	533	.050	15.0	263	39	1.75533
.190000	3512	.7109	4.4484	-1153	.087	43.302	537	.064	19.0	333	50	1.75535
.210000	3456	.7166	5.0608	-6393	.087	42.256	530	.078	23.0	403	61	1.75413
.230000	3311	.7038	5.5546	-9223	.088	41.227	509	.092	26.7	471	71	1.75124
.250000	3170	.6975	6.2245	-8175	.088	40.224	480	.106	30.6	530	81	1.74920
.270000	3003	.6729	6.7672	-8604	.088	39.254	463	.120	34.2	599	91	1.74436
.275317	3000	.6725	6.7755	-8704	.088	39.239	462	.120	34.2	599	91	1.74429
.290000	2946	.6557	7.2818	-6708	.089	38.320	439	.133	37.5	656	100	1.74136
.310000	2701	.6369	7.7712	-5974	.089	37.419	417	.146	40.7	711	108	1.73631
.330000	2572	.6248	8.2372	-4821	.089	36.548	397	.159	43.9	764	116	1.73334
.350000	2468	.6147	8.6843	-5031	.089	35.700	382	.171	46.7	814	124	1.72995
.370000	2368	.6034	9.1146	-5079	.090	34.871	366	.183	49.5	863	132	1.72521
.390000	2280	.5977	9.5293	-4088	.090	34.061	353	.195	52.2	909	139	1.72177
.410000	2195	.5905	9.9284	-3773	.090	33.269	340	.207	54.8	954	146	1.71821
.430000	2113	.5832	10.3141	-3563	.090	32.492	327	.219	57.3	997	152	1.71454
.450000	2028	.5741	10.6856	-3459	.091	31.733	314	.231	59.8	1038	159	1.71045
.462992	2000	.5703	10.8120	-3905	.091	31.471	310	.235	60.6	1053	161	1.70991
.470000	1959	.5662	11.0437	-3773	.091	30.929	303	.242	62.1	1078	165	1.70586
.490000	1890	.5633	11.3897	-2935	.091	30.200	293	.253	64.4	1117	171	1.70383
.510000	1821	.5565	11.7237	-2935	.091	29.545	282	.264	66.5	1154	177	1.69993
.530000	1748	.5451	12.0450	-4612	.091	28.846	270	.275	68.6	1189	182	1.69492
.550000	1676	.5389	12.3538	-2725	.091	28.164	259	.286	70.7	1224	187	1.68934
.570000	1613	.5330	12.6512	-2096	.092	27.495	249	.297	72.6	1257	193	1.68456
.590000	1557	.5258	12.9309	-2935	.092	26.841	240	.308	74.5	1298	197	1.68014
.610000	1494	.5171	13.2152	-3039	.092	26.200	230	.318	76.3	1319	202	1.67473
.630000	1434	.5104	13.4803	-2306	.092	25.576	220	.328	78.0	1349	207	1.66919
.650000	1368	.4974	13.7340	-3039	.092	24.969	210	.338	79.7	1376	211	1.66349
.670000	1305	.4909	13.9764	-1048	.092	24.380	200	.348	81.3	1403	215	1.65951
.690000	1255	.4747	14.2105	-4821	.093	23.807	191	.358	82.8	1428	219	1.65494
.710000	1192	.4652	14.4327	-3354	.093	23.244	181	.367	84.2	1453	223	1.64114
.730000	1135	.4564	14.6445	-2306	.093	22.704	172	.376	85.6	1476	226	1.63399
.750000	1082	.4438	14.8465	-3144	.093	22.181	163	.385	86.9	1498	230	1.62435
.770000	1028	.4376	15.0385	-2515	.093	21.675	154	.394	88.2	1519	233	1.61492
.785792	1000	.4377	15.1661	-1729	.093	21.334	150	.400	89.0	1530	235	1.60952

Propellants

SECT. 3 77F

BURNING RATE VERSUS PRESSURE

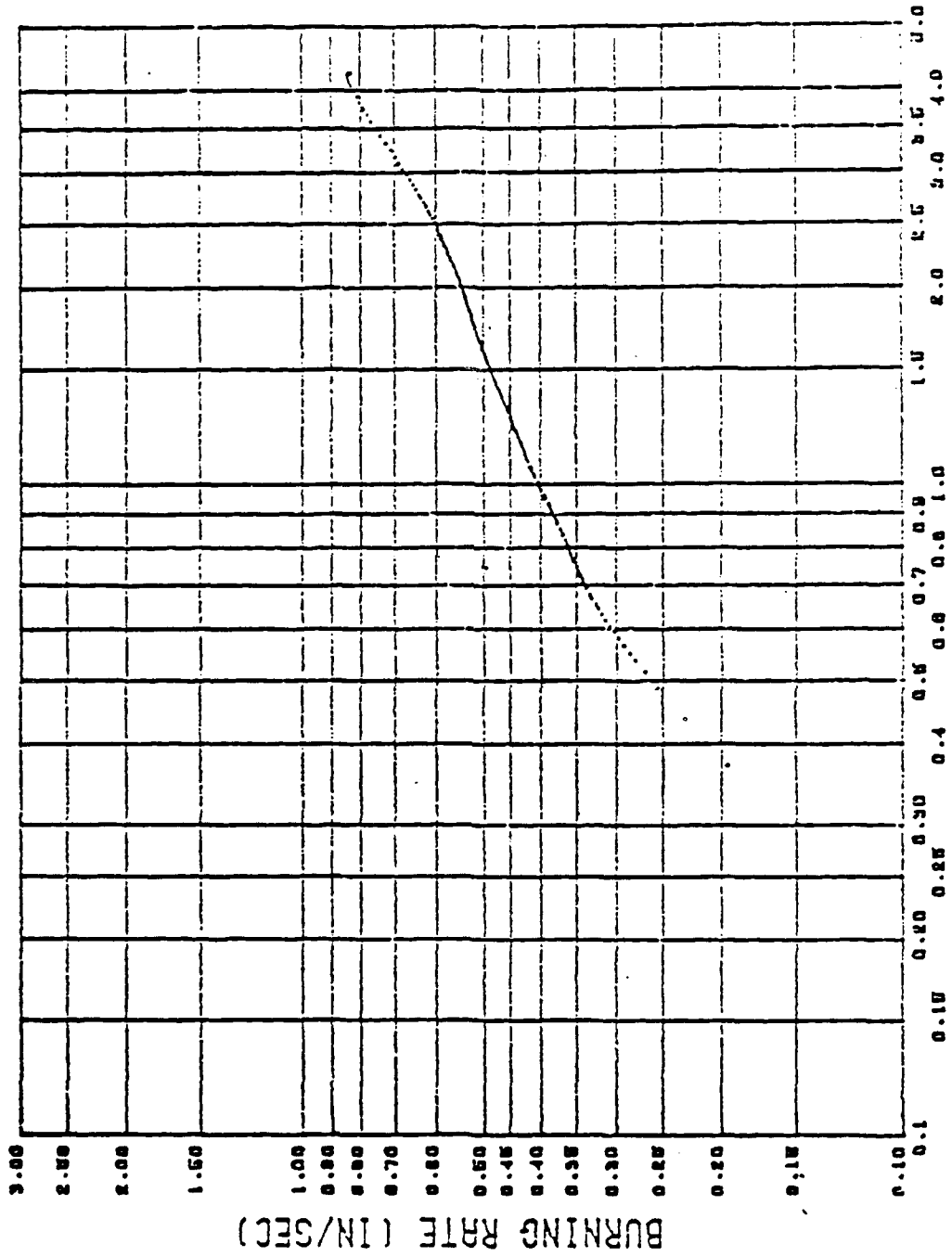

PRESSURE (PSIA X 10⁻³)

CHAPTER VIII GRAIN DESIGN

Motor impulse requirements and propellant I_{sp} establish how much propellant is required not how it must be configured in the motor. Consider the following thrust histories.

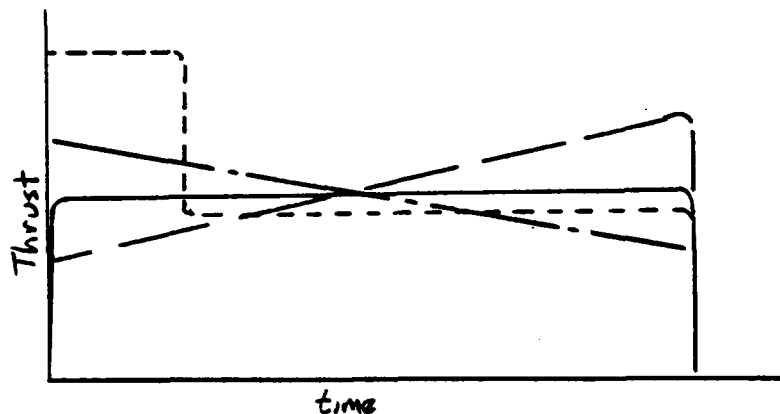

All four traces have the same impulse (area under the curve, remember?) and the same burn time, hence they have the same average thrust. Yet, they would give significantly different flight performances. Clearly, just knowing how much propellant is in the motor is not enough. We must know how to package it to do the job we want.

We have seen that thrust is proportional to pressure and that pressure is proportional to propellant burning surface. One of the primary tasks of the motor designer is to develop a grain with a surface history that corresponds to the desired thrust profile. For example, if we need a motor whose thrust increases steadily as it burns, we must package our propellant grain such that its burning surface increases as the propellant is consumed. A number of grain configurations of various complexities have been developed which package the propellant to suit our needs.

Definitions

Progressive burning –	burning surface increases as the grain burns.
Regressive burning –	burning surface decreases as the grain burns.
Neutral burning –	burning surface remains relatively constant.
Cross-sectional loading density (λ_{cs}) –	the ratio of propellant cross-sectional area to empty chamber cross-sectional area.
Port-to-throat area ratio, A_p/A_t –	the ratio of gas flow area in the grain perforation to the nozzle throat area.
Web thickness –	the dimension of the grain that determines the burning time.
Web fraction –	the ratio of web thickness to motor radius.
Slivers –	propellant remaining in the motor after the web thickness has been burned.

Modern solid rockets mostly use internal burning grains that insulate the chamber wall from hot combustion products. Many grains are cylindrical or consist of cylindrical parts. To determine the burning surface, A_b , of a cylindrical grain with length, L , it suffices to determine the burning perimeter, q , of the cross-sectional area. A_b can then be calculated by

Grain Design

$$A_s = \dot{q} * L$$

The determination of the burning surface of three-dimensional grains is more complicated.

As a propellant burns normal to its surface, a curved surface will propagate as a parallel curved surface. A surface convex towards the gas remains convex, and a surface concave towards the gas remains concave. A cusp, initially concave towards the gas will become an arc of a circle or sphere with its center at the original cusp.

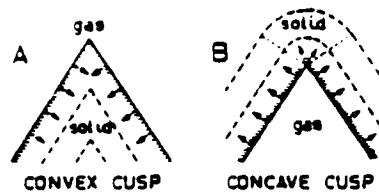

Effect of burning on a convex cusp (case A) and on a concave cusp (case B).

The determination of \dot{q} or A_s is a geometrical problem that can be solved by (analytical) geometry, graphical techniques or numerical procedures. With these methods one can determine A_s as a function of the distance burned. As there is a direct relationship between the distance burned, the burning rate, r_b , and the local pressure, P , the method is only applicable if there are no great differences in the burning rate along the grain, if the pressure is about constant along the grain length and in the absence of erosive burning. If this is not the case, one usually has to resort to numerical methods.

In some designs, a sudden decrease in burning surface may occur. In such a case the chamber pressure may become so low that either the combustion ceases, or that no effective thrust results anymore. Hence, the propellant left does not contribute to the propulsion and should be considered as a dead weight. This amount of propellant is called the sliver.

8.1 Cylindrical Grains

The **endburning grain**, or cigarette burning grain, is the simplest cylindrical grain. Its burning surface area equals its cross-sectional area. The upper limits on burning rates in combination with the grain diameter limit the mass flow and consequently the obtainable thrust. The use of the

endburning grain, therefore, is restricted to some very special applications, usually low-thrust, low performance motors with long burn times. Volumetric loading is reasonably good and the motors are ideally neutral burners. The center of gravity of such motors does, however, shift during motor burn.

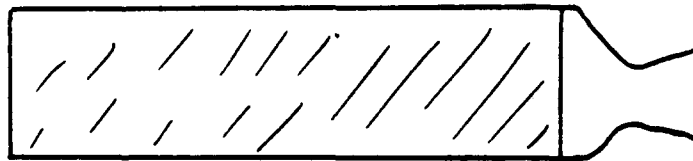

8.2 Internal Burning Tube

The first variation on the end burner is created by placing a hole down the full length of the grain. Combustion is then allowed to take place along the inner bore and the grain burns from the inside out. The propellant itself acts as insulation for the case throughout most of the motor operation. The end faces may either be inhibited or not. Sufficient port area must be provided for gas flow within the grain and loading density is correspondingly reduced.

Grain Design

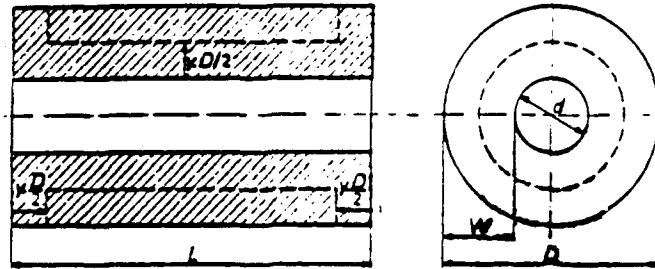

The tubular grain

The tubular grain will burn progressively if the ends are restricted, as the burning perimeter, Q , increases linearly with y (distance burned). If both ends, which burn regressively, are not restricted, it in fact becomes a three-dimensional burning grain, which, depending on the L/D ratio, can exhibit a fair degree of neutrality. The dimensionless burning surface, Σ , is depicted below as a function of y for some L/D ratios and fixed d/D . From the figure we conclude that for L/D around two fairly neutral burning can be obtained. The burning becomes more and more progressive with increasing L/D .

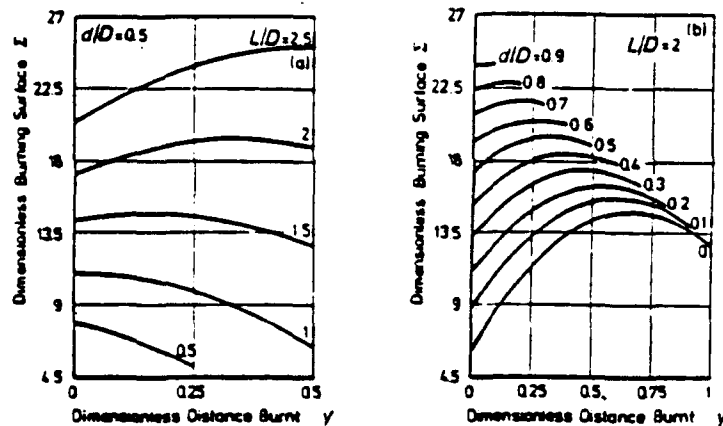

However, for chambers exhibiting a large L/D the grain can be segmented, each segment exhibiting an L/D that ensures neutral burning. This method is applied to many segmented motors, including the Space Shuttle Booster. Of course, those parts of the chamber walls exposed to hot combustion gases have to be insulated in proportion to their time of exposure. The figure depicts Σ versus y for various values of d/D and fixed L/D . The curve for $d/D = 0$ is a limiting case representing a massive cylinder, which is assumed to ignite along its central axis and both its end surfaces. The neutrality increases with increasing d/D .

8.3 Neutral Grains

Grains that exhibit pure neutral burning are the ID-OD burner burning radially at its inner and outer surface and the rod and shell, also with restricted ends. The first configuration exposes the chamber walls to the hot combustion products, while in both the configurations the grain support is difficult and complicated, and maintaining the structural integrity until burnout gives rise to serious problems.

Grain Design

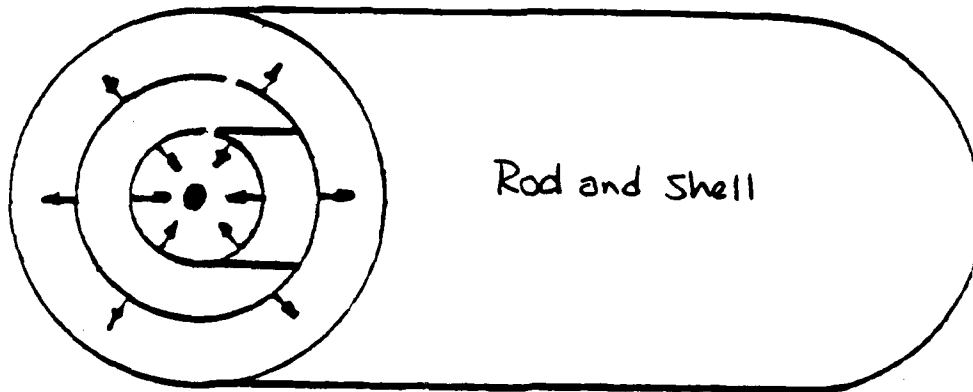
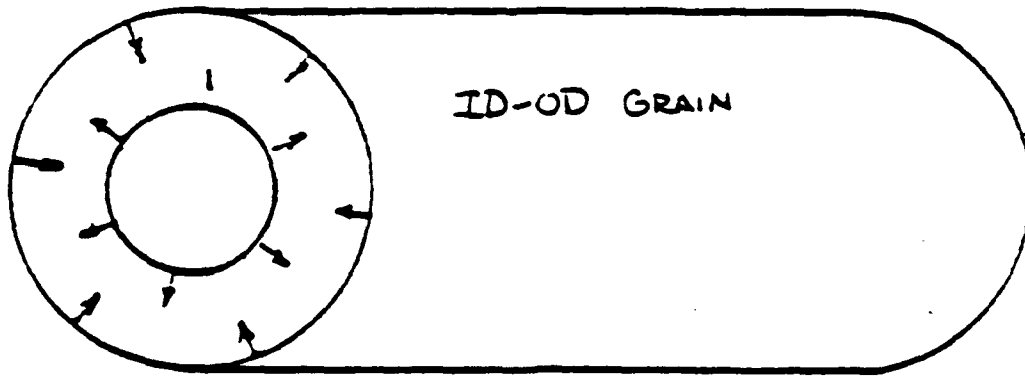

8.4 Noncircular Perforations

As we leave the realm of the circular perforations, we encounter grain designs of increased flexibility, more complexity, and increased slivers. (The grain geometries discussed so far have no sliver.)

The **star** configuration has been used in many solid motors. It is a radially burning cylindrical grain. Neutrality can be obtained by the interaction of the regressive burning star points and the progressive burning tube. The star is defined by six independent variables: N , ξ , η , r , w , and R . The burning perimeter of the star can be determined by analyzing a section such as depicted below. There are four different regions or phases.

Grain Design

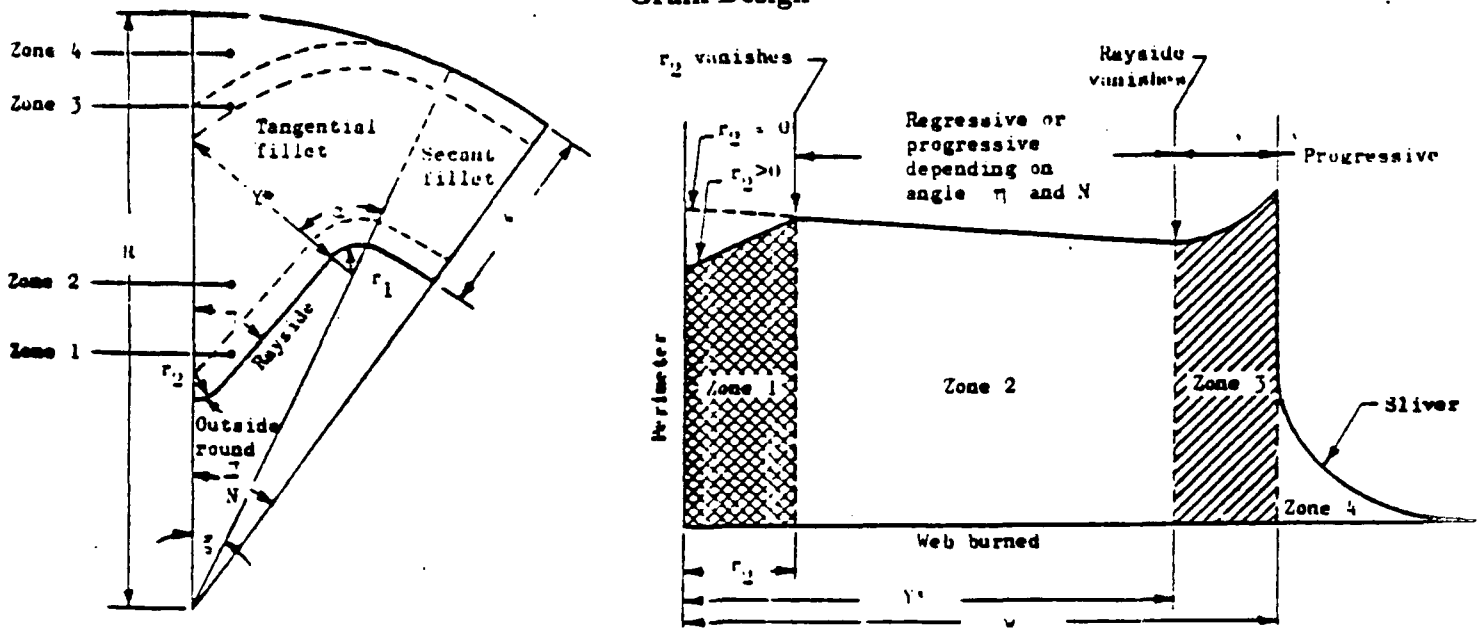

Regions I and II will burn regressively, neutrally or progressively, depending on r , ξ , and η . Region III will burn progressively, while region IV, the sliver, will burn regressively, if it burns at all.

In the Appendix, you will find a computer program (written in BASIC) which calculates the burning geometry of a star grain. Only the initial configuration is input. The program calculates the burning perimeter (LP) of the cross-section and the port area (AP) as functions of the distance burned (T).

The **wagon-wheel** is another often used grain configuration, with two more variables than the star: the length and angle β of the spokes. The wagon-wheel is used if small **web fractions** are required. Next to the conventional wagon-wheel there is also the **dendrite** or **forked wagon-wheel**. It may exhibit a higher volumetric loading fraction. The wagon-wheel configuration can exhibit more phases than the star as the number of phases increases with the number of independent variables. It is possible for the wagon-wheel that, when the spokes are all burned, the burning perimeter decreases discontinuously. Therefore, the wagon-wheel is suitable as a boost - sustain grain.

The **finocyl**, derived from "fins in cylinders", is used in many systems and can provide long burn times for relatively low L/Ds. The finocyl has axial slots to provide regressive burning to compensate for the progressive cylindrical section. Since the propellant under the slots burns out before the cylindrical section, a thick layer of insulation is needed in this area. The finocyl is sliverless.

Grain Design

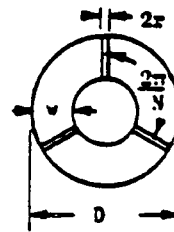
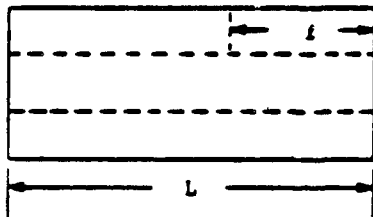
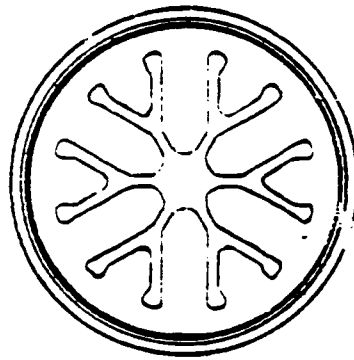
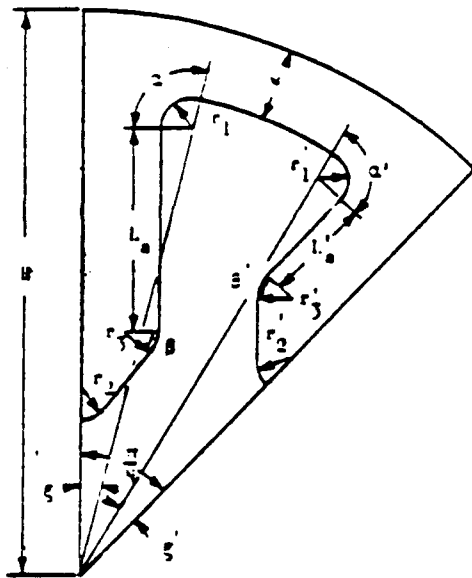
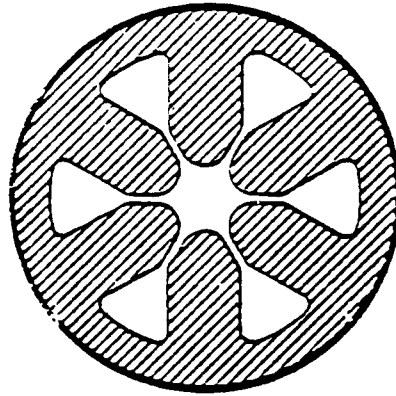
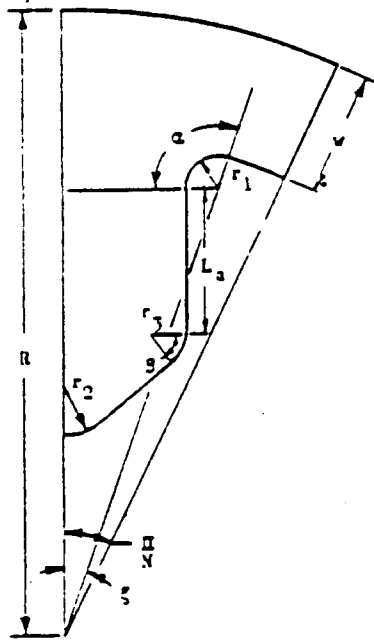

Grain Design

8.5 Dual Thrust Grains

Performance requirements occasionally call for a short period of very high thrust (boost) followed by a long period of low thrust (sustain).

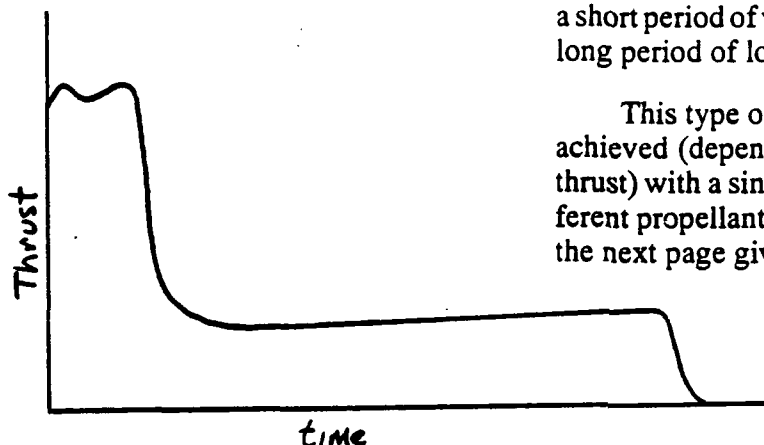

This type of boost-sustain performance may be achieved (depending on the ratio of boost to sustain thrust) with a single propellant grain or using two different propellants in the same chamber. The chart on the next page gives some examples.

Many other grain configurations have not been mentioned. The particular configuration selection is governed by (1) desired thrust history, (2) volumetric loading requirements, and (3) burn time/propellant burning rate. The resulting web fraction guides the grain designer to consider basic grain configurations. See the table below.

Table 1.—Suitability of Grain Configurations for Neutral-Burning Applications

Configuration	Length-to-diameter ratio	Web fraction in typical applications						
		<0.1	0.1-0.2	0.2-0.3	0.3-0.5	0.5-0.6	0.6-0.9	>1.0
End burner	NA ¹							X
Internal-external-burning tube	NA				X			
Internal-burning tube	<2					X	X	
Segmented tube	>2					X	X	
Rod and shell	NA				X			
Star	NA				X	X		
Wagon wheel	NA		X	X				
Finocyl	1 to 2						X	

¹not applicable

DUAL THRUST GRAINS

Single Propellant Systems	
	<p>Boost: radial burning Sustain: end burning</p>
	<p>Boost: radial burning Sustain: radial burning</p>
Dual Propellant Systems	
	<p>Boost: radial burning Sustain: radial burning Concentric full length.</p>
	<p>Boost: radial burning Sustain: radial burning Concentric in aft end</p>
	<p>Boost: radial burning Sustain: radial burning Tandem with boost aft</p>
	<p>Boost: radial burning Sustain: radial burning Tandem with boost forward</p>
	<p>Boost: end burning Sustain: end burning Tandem with boost aft</p>

CHAPTER IX HARDWARE COMPONENT DESIGN

In order to achieve desired performance, it takes much more than the correct propellant configured in the proper grain design. There are other, inert components that must all function correctly. These other components are the chamber, nozzle, insulation, and igniter. It should be clear by now that the operating environment for a rocket is not very friendly – pressures reaching 3500 psi and temperatures approaching 6000°F. These types of constraints limit the motor designer in many ways. Also imposed on the designer are requirements to minimize inert weight (remember the ideal burnout velocity?), cost, and complexity of components. Satisfying all these constraints is a difficult task. It involves a careful study and analysis of both the structural and the thermal loads placed on each component.

It is to the design and analysis of these hardware components that we now turn our attention.

9.1 Chamber and Nozzle Design

The chamber–nozzle assembly is the basic pressure vessel for a solid rocket. Materials for these two components are usually the same, therefore much of our discussion will be concerned with the assembly rather than individual nozzle and chamber.

The chamber of the solid propellant rocket contains the grain and has to withstand pressure, starting surges, and often severe heating. The exact pressure to which a chamber is subjected is often difficult to determine, because some grains (and some igniter designs) cause momentary high pressure surges. As insurance in this situation, chambers are usually designed for pressures significantly higher than those expected during normal operation. These “safety factors” depend upon past experience, expected variations in grain performance, and quality control of the manufactured chambers.

An important “design pressure” for chamber design calculations is the Maximum Expected Operating Pressure (MEOP). The MEOP is defined as the statistical maximum pressure under normal operating conditions. A good rule of thumb for MEOP is **ten percent over the maximum pressure at the hot operating temperature**. (Remember that motor pressure increases with temperature . . . temperature sensitivity).

$$\text{MEOP} = P_{\text{max hot}} * 1.10$$

A safety factor is included to make sure the rupture pressure of the chamber is at least 1.5 times MEOP.

$$P_{\text{burst}} \geq 1.50 * \text{MEOP}$$

This burst pressure is determined experimentally on a representative sample of chambers.

Okay, so now we have a pressure, P_{burst} , that we want the chamber to withstand. How do we relate this to a required chamber wall thickness? Let’s look at the cross–section of a cylindrical motor chamber:

Hardware Design

If we split our case in half we can look at the forces acting on it

According to Newton's 3rd law, the reactive force within the chamber wall is equal to the pressure force

$$\text{Reactive force} = \text{Pressure force}$$

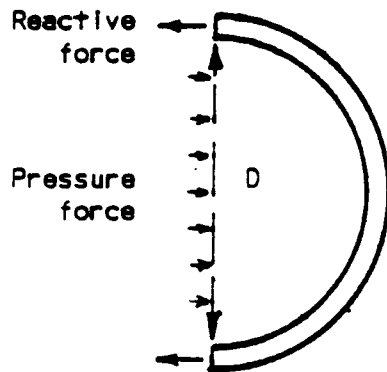
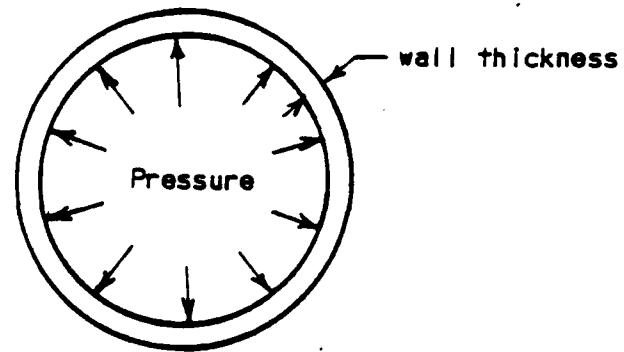

If L is the length of our chamber and D is the internal diameter, the pressure force is

$$\text{Pressure force} = P_c * D * L$$

The reactive force is due to an internal material "pressure" or stress (σ) acting on the material cross-section

$$\text{Reactive force} = \sigma * \tau_{\text{wall}} * L * 2$$

where τ_{wall} = thickness of the chamber wall.

So, now we have,

$$2\sigma\tau_{\text{wall}}L = P_cDL$$

$$\tau_{\text{wall}} = \frac{P_cD}{2\sigma}$$

This equation allows us to calculate the wall thickness necessary to contain a given pressure. The stress value (σ) is dependent on the chamber material and is an indication of the strength of the material. The vast majority of rocket chambers today are composed of either steel or aluminum. Typical strength levels for these materials are

$$\sigma_{\text{steel}} = 100,000 - 200,000 \text{ psi}$$

$$\sigma_{\text{aluminum}} = 50,000 - 80,000 \text{ psi}$$

(Note in the above equation that the required wall thickness is a function of the chamber diameter, D . For any given pressure and material, as the diameter increases, so must the wall thickness).

The strength of the chamber is determined in part by the temperature of the material. It's been found that as metal becomes hotter, its strength diminishes. As an example, at 1200° F, steel has lost roughly 70 percent of its strength at room temperature. Therefore, it is good design practice to limit the heating of rocket chamber walls.

Hardware Design

The chamber design must also provide for the attachment of a nozzle and igniter and must provide for loading the grain. The figure on the next page (of the MK56 rocket motor) shows features typically found on solid rocket motors.

The nozzles of solid propellant rockets, like the chambers, are usually uncooled. The nozzle is subjected to severe conditions because of the high heat transfer rates and because of the mechanical erosion effects of the hot, high velocity gases which contain entrained particulates.

The stress calculations on nozzles are complex because of the several different loading conditions. The exhaust pressure decreases as the gas flows through the nozzle causing longitudinally-varying axial and hoop loads. These have to be added to the stresses caused by very steep thermal gradients.

For low temperature propellants and short durations, simple steel nozzles are adequate. The nozzle on the following page is a typical example. For longer durations and high temperature corrosive propellants, inserts of special materials are put into the throat section (tungsten, various carbides, molybdenum, or graphite). The use of reinforced phenolics which carbonize slowly or char during motor burn has been successful in many applications. The second nozzle sketch which follows shows the complexity of high performance nozzles.

The joint between the chamber and nozzle must be strong and leak-proof. Numerous methods of attachment are in current use. Several of the most common joints are shown in a following sketch. In each case note the thickening of each component in the joint area. This is done in order to make the joint more structurally sound. Also note in each example the presence of a seal to prevent gas from escaping through the joint.

Sophisticated, Finite-Element Modeling (FEM) of the nozzle (and case) is performed in order to evaluate in detail the adequacy of the component. A typical FEM grid and thermal contour plot are shown in the figures which follow.

Hardware Design

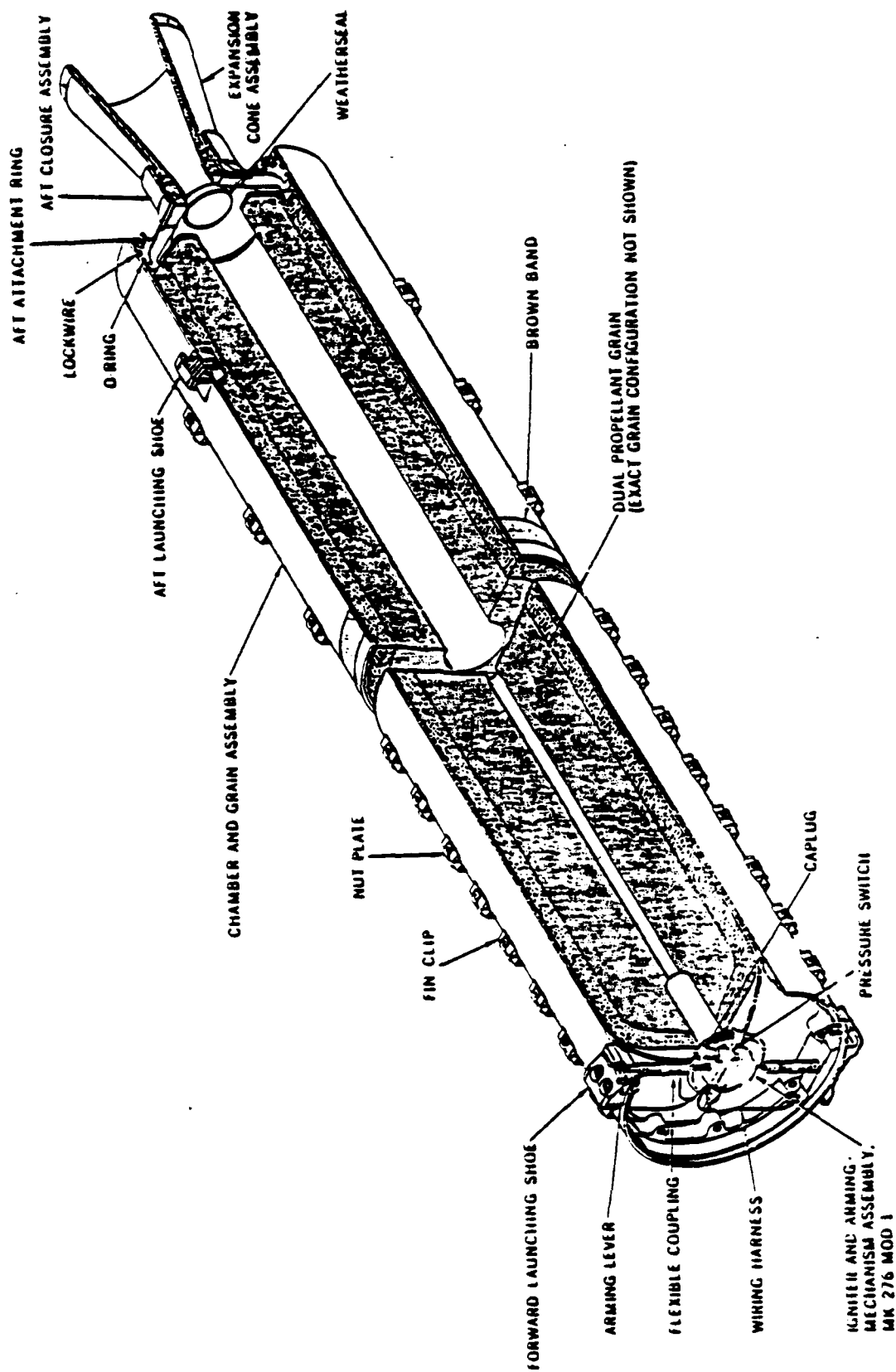

Rocket Motor Mk 56 Mod 1 and 2, Cutaway

Hardware Design

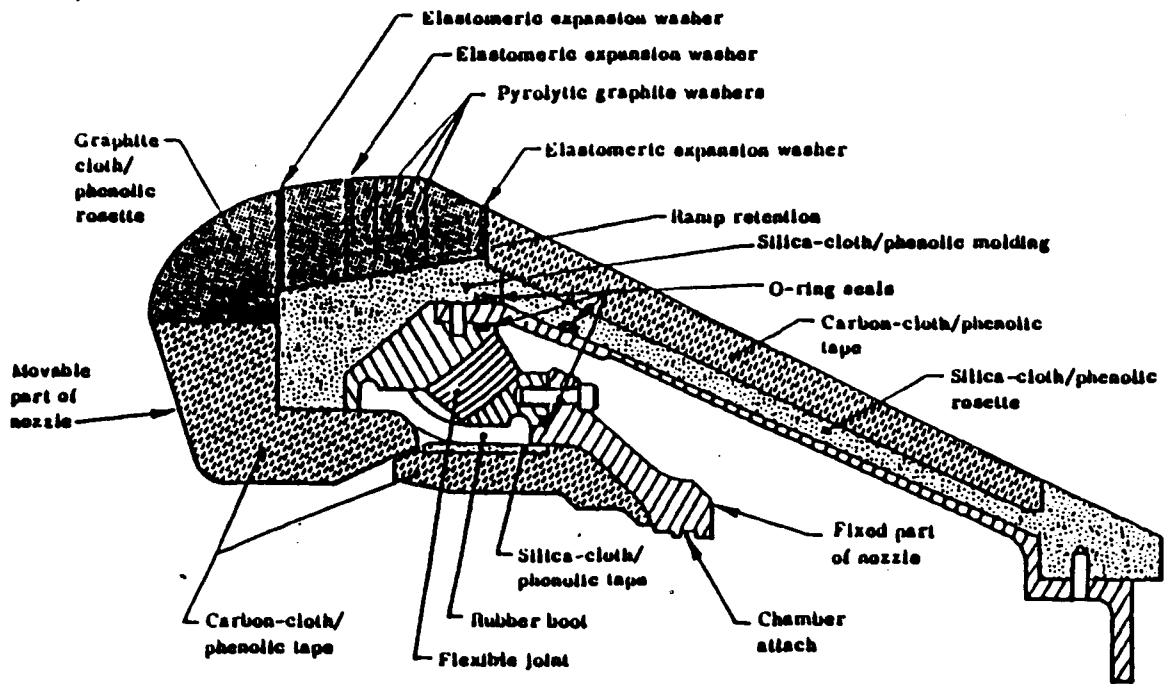

Provisions for thermal expansion of throat insert.

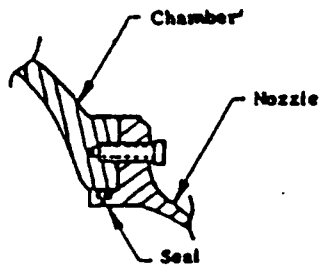

(a) Bolted

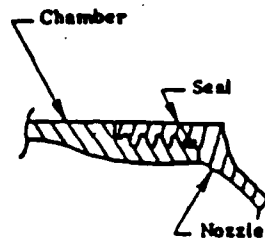

(b) Threaded

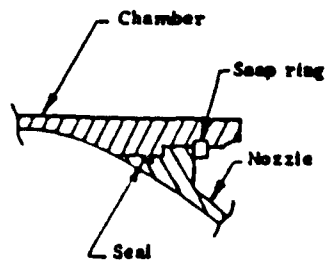

(c) Soap ring

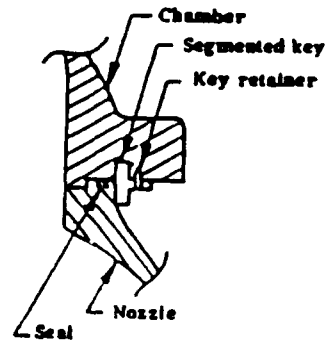

(d) Key

Basic methods for attaching nozzle to chamber.

Hardware Design

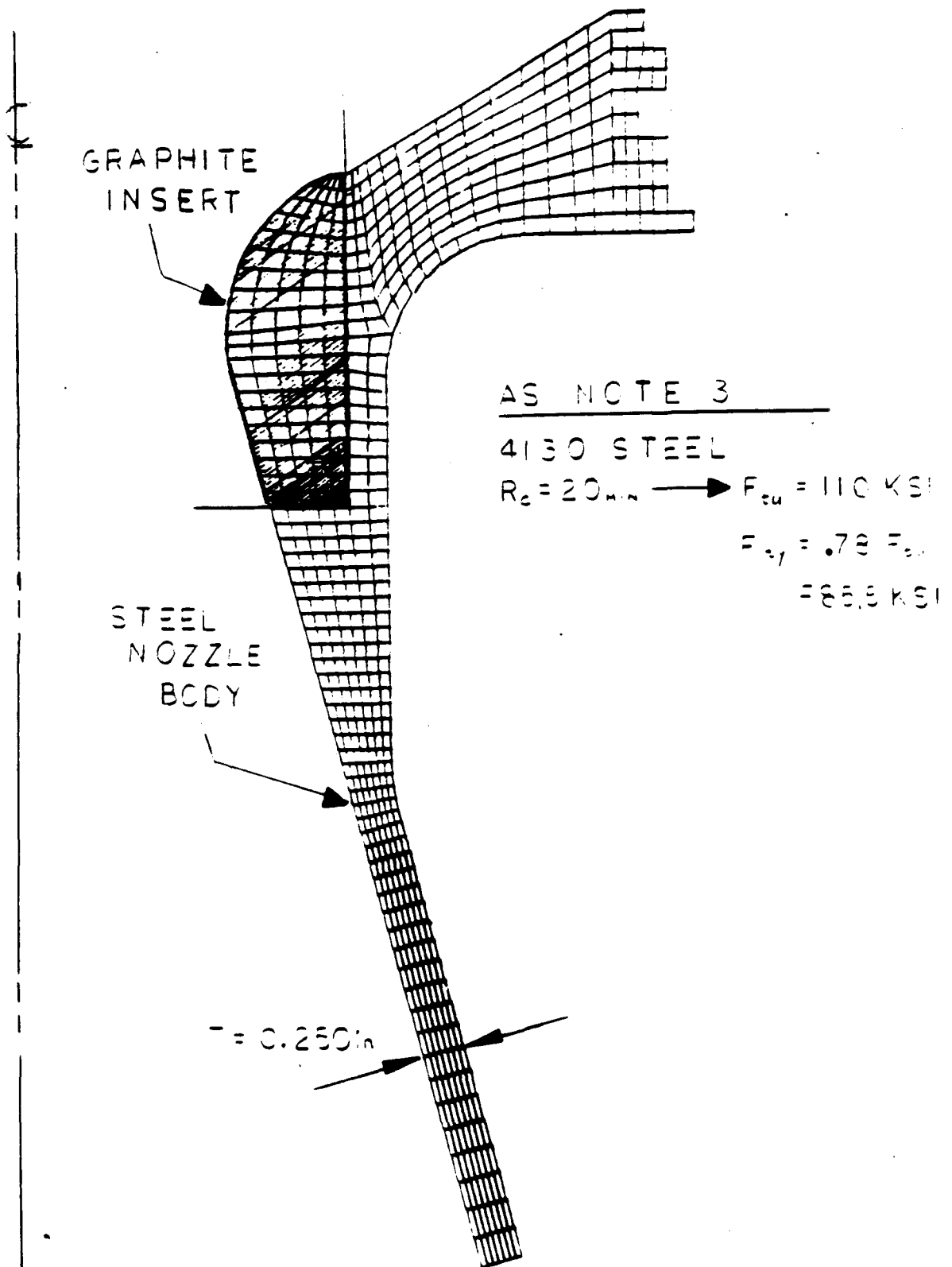

Hardware Design

TEMP.

N O.	VALUE
1	+0.00E-00
2	+4.00E-02
3	+8.00E-02
4	+1.20E-03
5	+1.60E-03
6	+2.00E-03
7	+2.40E-03
8	+2.80E-03
9	+3.20E-03
10	+3.60E-03
11	+4.00E-03

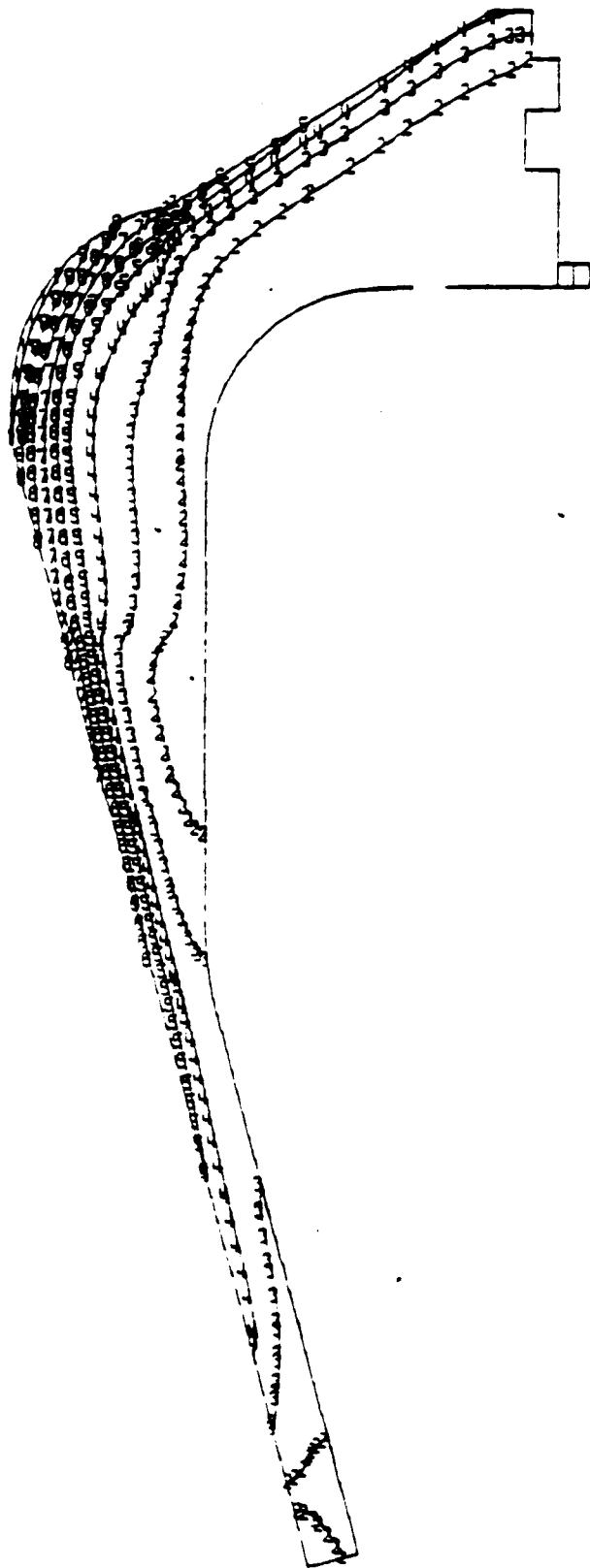

Hardware Design

9.2 Liners, Insulators, and Restrictors

We have seen that the motor chamber and nozzle must have thermal protection if they are to maintain their design capabilities throughout motor operation. Insulating materials must serve several functions: (1) provide an "adhesive" layer between the propellant and chamber, (2) insulate the chamber, and (3) prevent the propellant from burning on undesired surfaces. The number of components varies, of course, with the design requirements. There are three major categories which have the following functions:

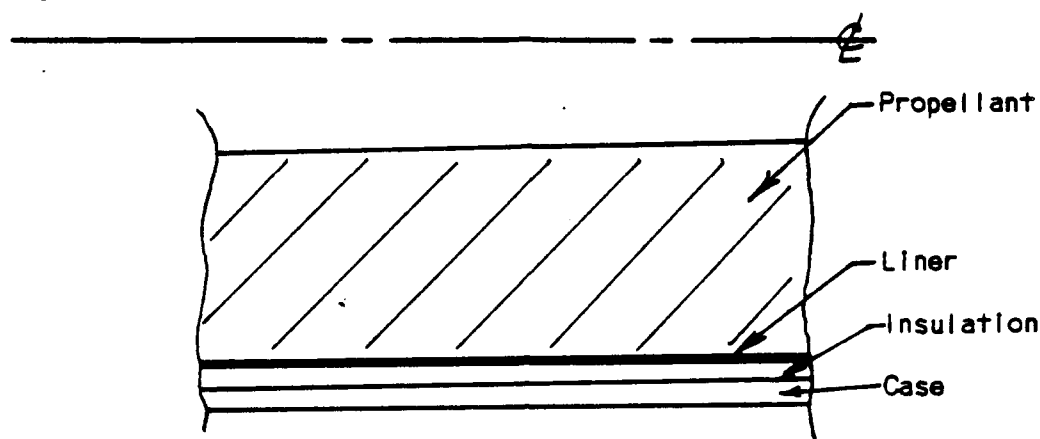

INSULATOR, an inert thermal barrier, positioned and bonded to the case wall or other areas where the combustion flame may impinge. The primary function of the insulator is to prevent case weakening during rocket motor operation.

LINER is applied to the case interior as a means of ensuring propellant adhesion to the case structures. The liner also provides "external" inhibition of the propellant grain should the liner become separated from the case or insulator.

INHIBITOR/RESTRICTOR names apply to materials which perform the function of preventing the ignition or burning of the propellant grain.

Once the requirements for each component are determined then the material selection may begin. There are generalizations which may be applied to the selection of specific materials. Liner formulations should be similar to the propellant (i.e. identical polymers and curatives) for chemical compatibility. The incorporation of filler materials such as carbon black is necessary to provide increased viscosity and greater insulation properties. Inhibitors are generally solid material which are applied to propellant grains, or to containers into which propellant is cast. Inhibitors are selected based on their compatibility with the propellant grain. Mechanical and physical properties of the inhibitor should be matched to the requirements of the motor and propellant. The use of a material which is brittle at -40°F is of no use in a motor which must function at -65°F . Restrictors perform the same functions as inhibitors.

The distinction we use is that restrictors are generally liquid or paste systems with curatives which are applied to propellant surfaces to prevent burning.

Insulators are required when relatively long motor burn times are specified. Selection of insulators is based on the general parameters of heat conduction, thermal properties, etc. The more common insulator materials are glass or asbestos phenolic and polyisoprene rubber.

Hardware Design

9.3 Igniters

The igniters used for solid propellant rockets are of two basic types: **pyrotechnic** and **pyrogen**. The function of either is to provide ignition of the main propellant grain by the generation of an initial burst of hot gases or a combination of gases and particulates. In most designs, the igniter is placed in the forward end of the chamber so that the ignition gases will sweep past the entire grain before exiting the nozzle. Some nozzle-end ignition designs exist, however they must be properly configured to provide a satisfactory ignition blast forward into the motor.

A pyrotechnic igniter is shown in below and usually contains an electrically heated wire, which is surrounded by a small amount of primer (usually less than one gram). The primer propellant is a substance which is sensitive to temperature and will ignite readily and burn when heated. The main igniter charge is immediately adjacent to the primer. It produces a hot flame which ignites the rocket grain. Igniter cases are usually sealed to prevent absorption of moisture and to control the ignition at high altitudes. Some igniter cases are made of a plastic so that they will burn and therefore will not form an obstruction to the gas flow. The igniters, like the propellant charge, must be resistant to moisture and capable of storage and operation over a wide range of operating environments.

The igniter charge for pyrotechnic igniters consists of an energetic material (BKNO_3 , MTV, black powder, etc) configured in pellets, sticks or granules. It ignites the motor through conduction, convection, and radiative heat transfer. Pyrotechnics are relatively cheap and are commonly used on small, high production motors.

The pyrogen type igniter is really a small rocket motor itself—complete with nozzle and its own booster charge, or igniter. The igniter charge is a small propellant grain which produces hot gases to ignite the main rocket motor grain chiefly through convection. The longer functioning time and more complex design is necessary for many larger rocket motors.

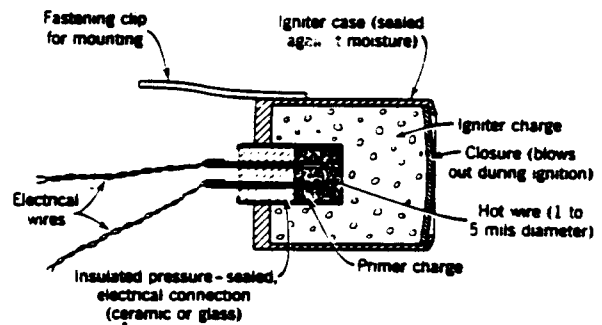

Schematic drawing of typical pyrotechnic igniter.

Some of the principal design considerations in igniters are the type, grain size, formulation, and moisture content of the igniter propellants, the construction and fastening of the igniter case, the location of the igniter with respect to the grain, the surface condition of the main charge, the size, direction, shape, and temperature of the ignition flame, the nozzle closure rupture pressure, the amount of hot solid particles in the igniter gases, the time delay between electrical signal and first pressure, the amount of debris ejected through the nozzle at the start, the electrical energy required to initiate, the time-pressure relationship between igniter pressure, the operating pressure of the rocket, and the variation of igniter characteristics with temperature. With these many variables, many of which are closely interrelated, it has not been possible to postulate a good ignition theory, and an empirical approach has generally been satisfactory.

Hardware Design

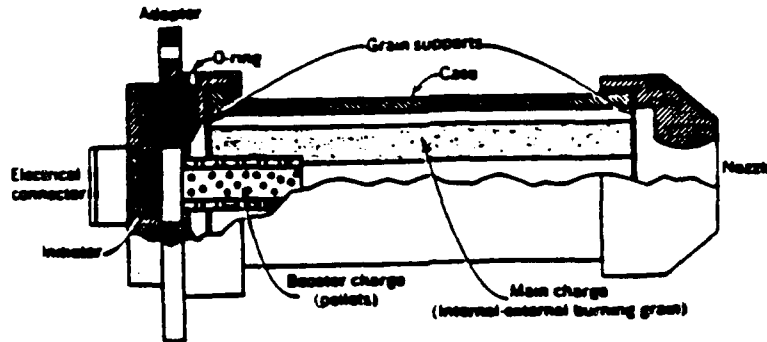

The ignition transient process is shown below. Phase I is the ignition lag time or induction interval which covers ignition switch closure, primer and igniter charge burning, and initial discharge into the motor grain port. Phase II covers the heat transfer and ignition of the main propellant grain and the spreading of flame over the entire propellant surface. As the grain comes to full ignition, motor pressure rises due to chamber filling until steady state equilibrium is reached (Phases II and III). Note the short time interval associated with the ignition transient. It is almost instantaneous and is often treated as such in calculations.

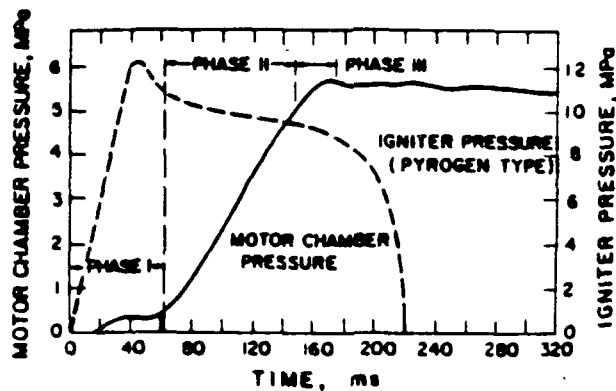

CHAPTER X PREDICTION

The design of a solid rocket motor is an iterative process involving many technical disciplines. It is very much a team effort by a closely communicating group of individuals. To try to depict the flow of the design process is difficult, but the results might look something like

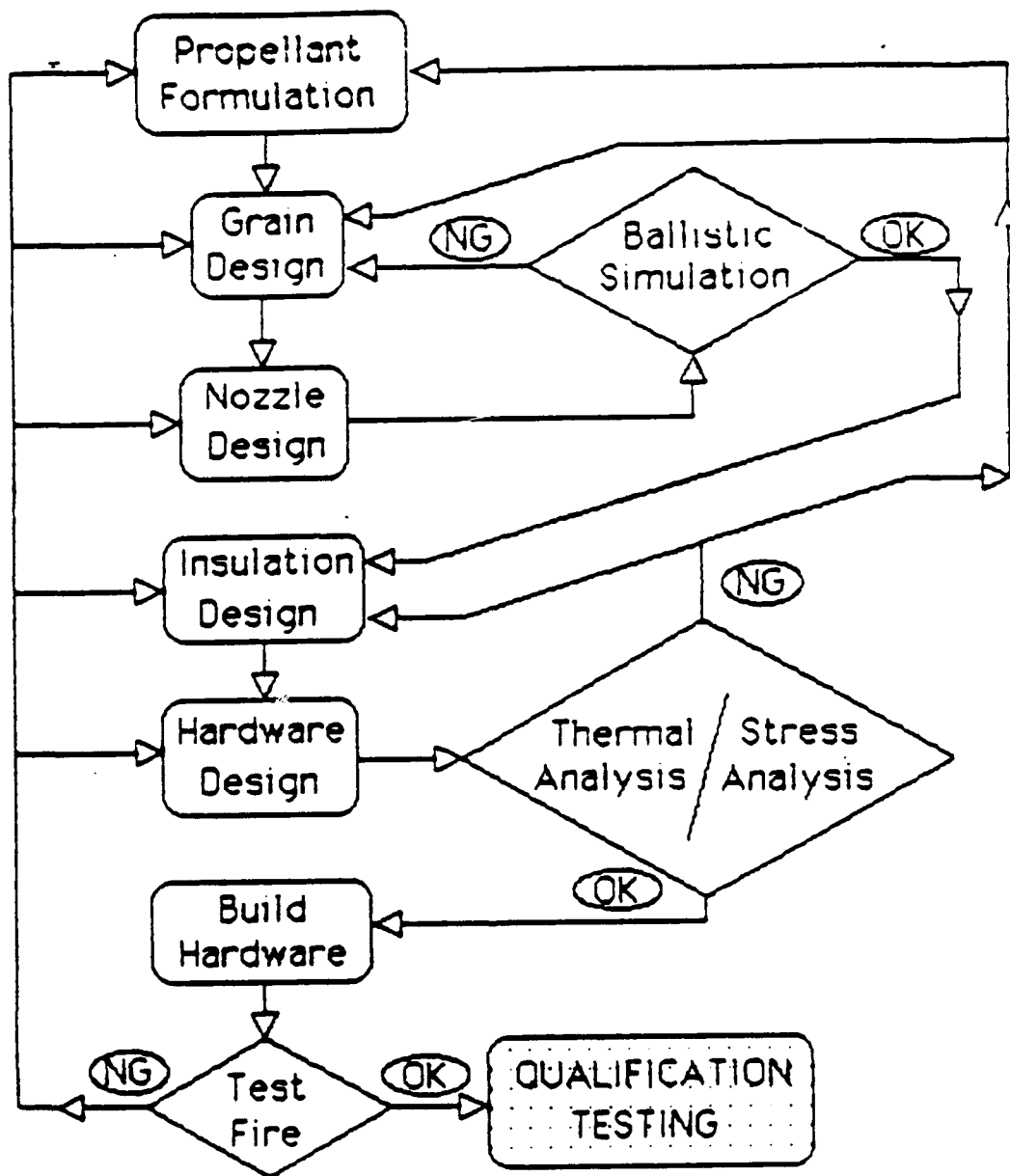

Prediction

We begin with a preliminary selection of propellant, grain design and nozzle design and then (making the necessary compromises) determine the combination which yields the desired ballistic performance. We then follow up with the structural and thermal studies necessary to define the inert hardware design.

By the time we reach this point we have applied the following laws to the development of our design:

Newton's Laws of Motion,
Conservation of Mass, Momentum, and Energy,
Thermodynamic relationships.

Having thus done our "homework" on the design, we fabricate a prototype motor and test it. This is always a time of uncertainty for the design engineer. Why? The truth is that there is one overriding law – actually a set of laws—which have been recently discovered whose implication to engineering often carries dire consequences. This is the law attributed to Edsel P. Murphy.

Murphy's Law—In any field of scientific endeavor, anything that can go wrong will go wrong.

A profound statement that continues to withstand the test of time.

Numerous corollaries to Murphy's Law have arisen. Some of these are

—If there is a possibility of several things going wrong, the one that will go wrong is the one that will do the most damage.

—Nature always sides with the hidden flaw.

—If everything seems to be going well, you have obviously over-looked something.

What has this got to do with rocket motor design? Han Solo summarized it well to Luke Skywalker in Star Wars when he said "Don't get cocky." We never plan for EVERYTHING, though we like to think we do. As we've said, rocket motor design is still far from an exact science.

10.1 First-Order Preliminary Design (FOPD)

With that caveat out of the way, we turn to the task of motor performance prediction. Where do we start? We know enough at this point to conduct what we might refer to as a First-Order Preliminary Design (FOPD) given a basic list of performance requirements. Its called "first-order" because it makes a number of simplifying assumptions. We exclude time-dependent trends and assume only average performance. We do not concern ourselves (at this point) with details of a grain design but only determine gross parameters such as total volume of propellant. As an example, we may know a desired average thrust, average chamber pressure, and total impulse for our design to meet. We then must determine other parameters such as burn time, specific impulse, and required propellant weight to meet the desired performance.

You've seen all the equations before. They've been combined into the BASIC computer program listed in the appendix. Inputs are lumped into performance, propellant, and nozzle categories. The output should be self-explanatory. Temperature dependent parameters are grouped separately.

Prediction

This is an excellent program for getting a preliminary idea of the size of the rocket motor. The **FOPD** program is in daily use at MICOM. Note that, other than TAUW, ASBAR, and VFT no mention is made of grain configuration—any grain satisfying those three constraints will provide the necessary performance. The **FOPD** program is perfect for answering questions like: “What happens if density is increased five percent?” or “What happens if the nozzle exit diameter is increased 0.5 inch?” Try it on your personal computer. You’ll be surprised at how quickly you will pick up on the subtle interrelationships among all the parameters.

10.2 Motor Ballistics (MBAL)

Its obvious that if we are concerned about erosive burning or mass addition, we need more than an **FOPD** program. We need state-of-the-art modeling capabilities. Numerous computer programs exist to model motor performance in detail. Each propulsion facility has its own pet programs. A typical one is **MBAL**.

It is a large jump from the simple performance calculation of **FOPD** to a state-of-the-art ballistic model like **MBAL**. It is impossible to cover, in a short text, the detailed workings of **MBAL**. An outline and brief description can, however, point out its differences and improvements over **FOPD**.

Like **FOPD**, **MBAL** requires inputs of propellant ballistic and physical properties, and nozzle geometry. In addition, **MBAL** requires a description of the initial propellant grain geometry. Primary computed outputs are chamber pressure, thrust, mass flow rate, pressure-time integral, impulse, and propellant weight at selected intervals of burning time. The solution is based on the assumption of equilibrium at each point in time. Pressure variation down the grain due to mass addition is included in the calculations. An optional mode is available for automatic plotting of the computed variables with respect to motor burning time.

Additional miscellaneous inputs are used to control calculation intervals, print options, plots options, and input loading sequence. The program input technique is designed to minimize the effort required of the user. For example, a simple motor configuration may require only about 30 inputs. However, the program has the capability of accepting more than 7300 inputs values if every possible input option is used simultaneously.

Prediction

—— GEOMETRY INPUT AT THIS PLANE
- - - GEOMETRY INTERPOLATED AT THIS PLANE

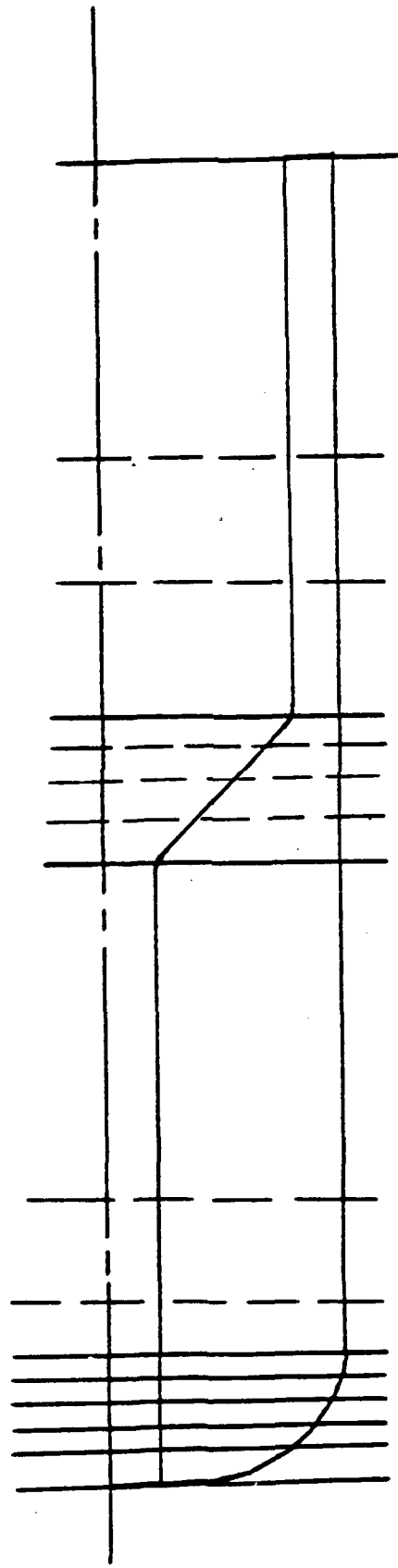

MOTOR SECTIONING FOR MBAL

Prediction

The propellant grain is divided into a number of segments for description. Details of the grain geometry are input at key locations such as those indicated on the previous figure. Geometry information at intermediate planes is determined in MBAL by linear interpolation between the key planes. The resulting motor segments then become the segments over which we determine mass addition influence (remember that?). The number of planes (segments) may range from a minimum of two in very simple designs to a maximum of 100, thus providing considerable flexibility to vary the propellant configuration.

Three basic grain cross-section geometries are "built into" MBAL. These are the wagon-wheel, the slotted tube, and the dogbone. Figures below show the input variables associated with these geometries. These configurations are so general in nature that 95 percent of all rocket grains can be described using one (or more) of them. For instance - the wagonwheel becomes a star if parameter LS2 is set equal to zero. As another example, the slotted tube becomes a simple internal burning cylinder if parameter R5 is set equal to R2.

The full set of equations are programmed into MBAL which compute the burning surface of each configuration automatically. The user only needs to input the initial configuration and then the computer takes over.

The following assumptions are made by MBAL:

- (1) Combustion gases follow steady flow laws.
- (2) Combustion products are considered to be "Perfect Gas".
- (3) Only radial burning in the cylindrical section.
- (4) Linear variation of burn rate along an increment.
- (5) The port perimeter of an increment is defined as the average of the two ends of the increment. Propellant burning surface is equal to this perimeter times the increment length.
- (6) Linear variation for all interpolations.
- (7) Mass flow is at equilibrium at each time increment.

An outline of the MBAL calculating sequence goes something like:

- I. Calculate propellant perimeter and port area at each input plane.
- II. Calculate the burning surface and propellant volume along the grain.
- III. Assume a value for head end chamber pressure.
- IV. Compute: Propellant burning rate, pressure, flow rate, temperature, velocity, specific weight, and Mach number of the chamber gas at the next plane downstream using conditions at the previous plane.
- V. Repeat steps III and IV for each plane until the end of the grain is reached.
- VI. Calculate gas discharge rate through the nozzle throat using nozzle end pressure.
- VII. Compare discharge rate to generation rate.
- VIII. Repeat steps III through VII until weight generated is equal to the weight discharged through the nozzle.
- IX. Calculate motor thrust.
- X. Increment time and thickness burned at each plane using the parameters calculated for that plane in Step IV. Thickness burned is burn rate, times the time increment.
- XI. Repeat the entire analysis for the new time increment.
- XII. Terminate when weight generated is equal to zero or other input cut-off conditions are met.

Simple, huh?

Prediction

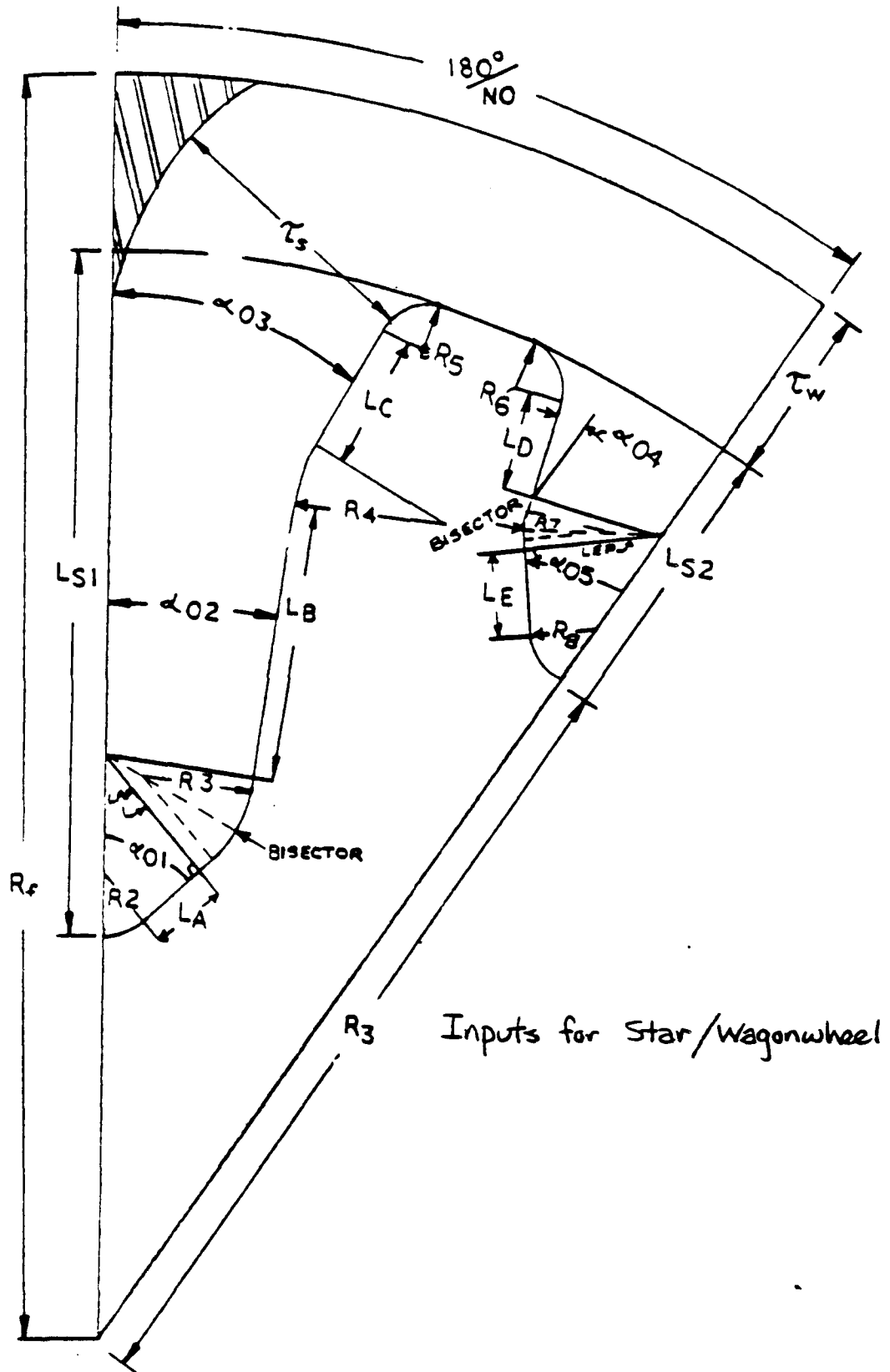

Prediction

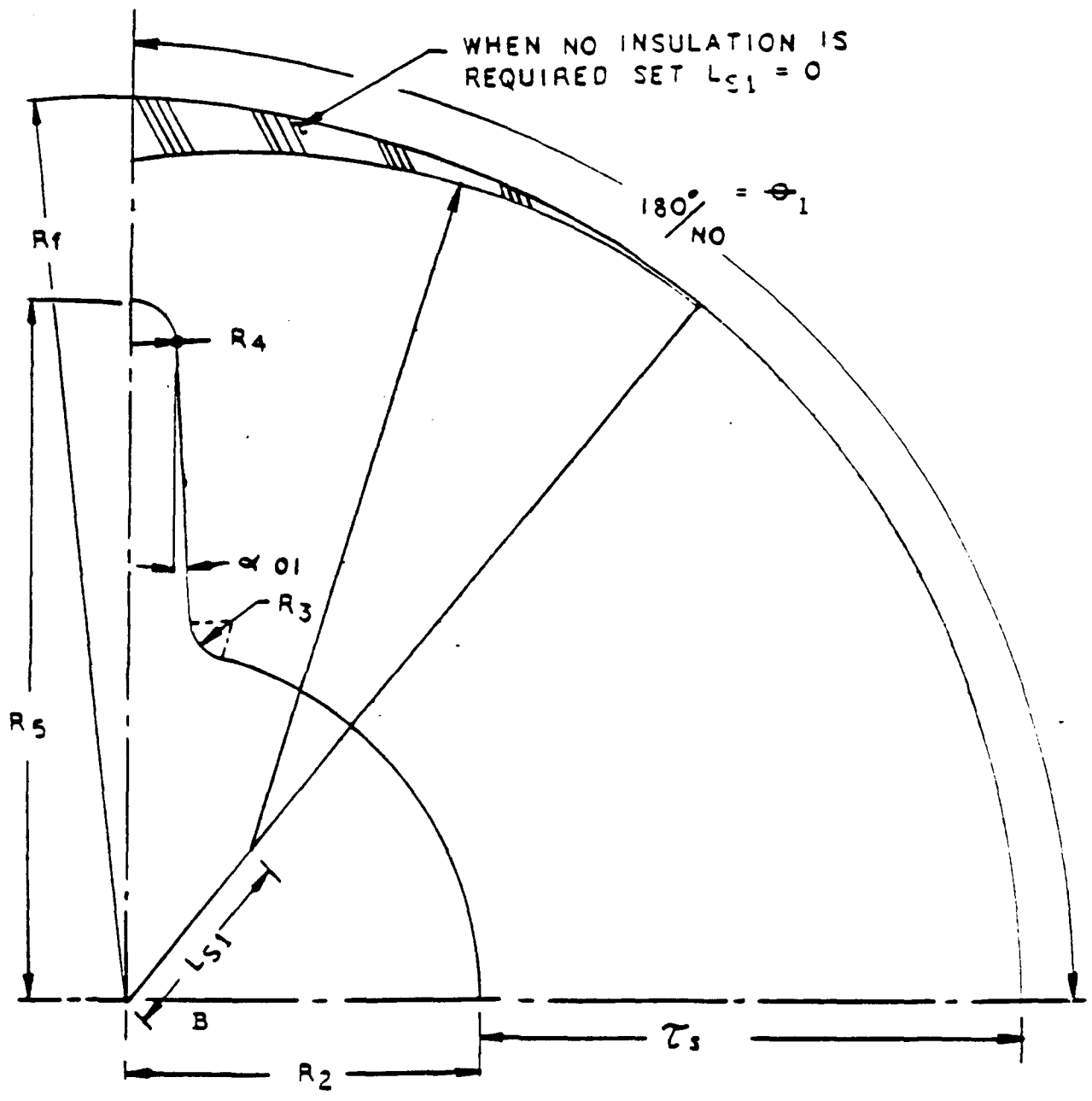

Inputs For Longitudinal Slotted Configuration

Prediction

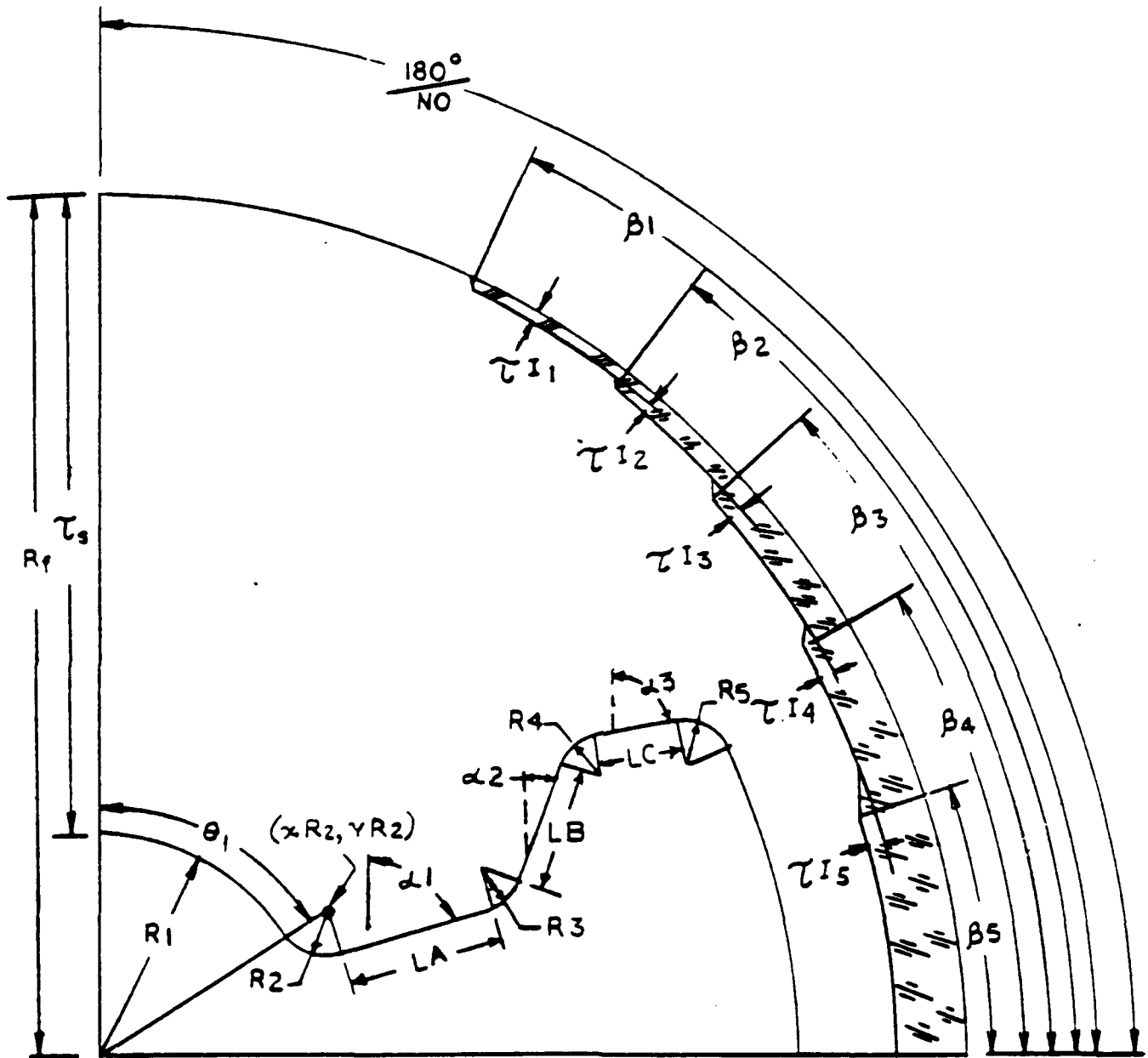

Inputs for Dogbone

Prediction

A sample simulation follows which includes a motor sketch, description of input, and tabular and plot outputs. The input format is probably foreign to you—don't worry about it. Just pay attention to the types of input information required.

The output begins with a regurgitation of the user input followed by a plane-by plane geometry description (several pages of which have been mercifully omitted in this copy). Following the geometry comes the time-dependent performance. Lastly, a plot is generated of the pressure and thrust history.

Prediction

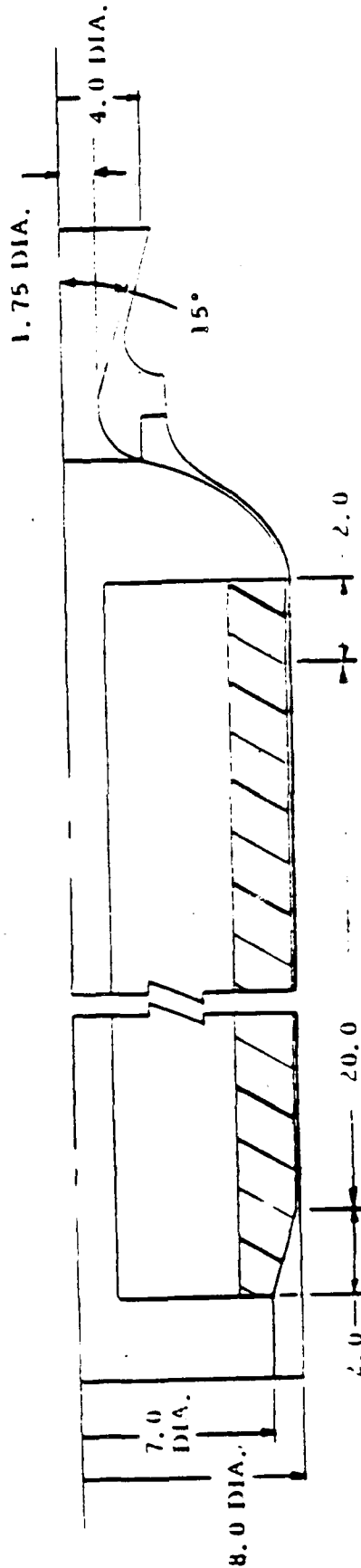
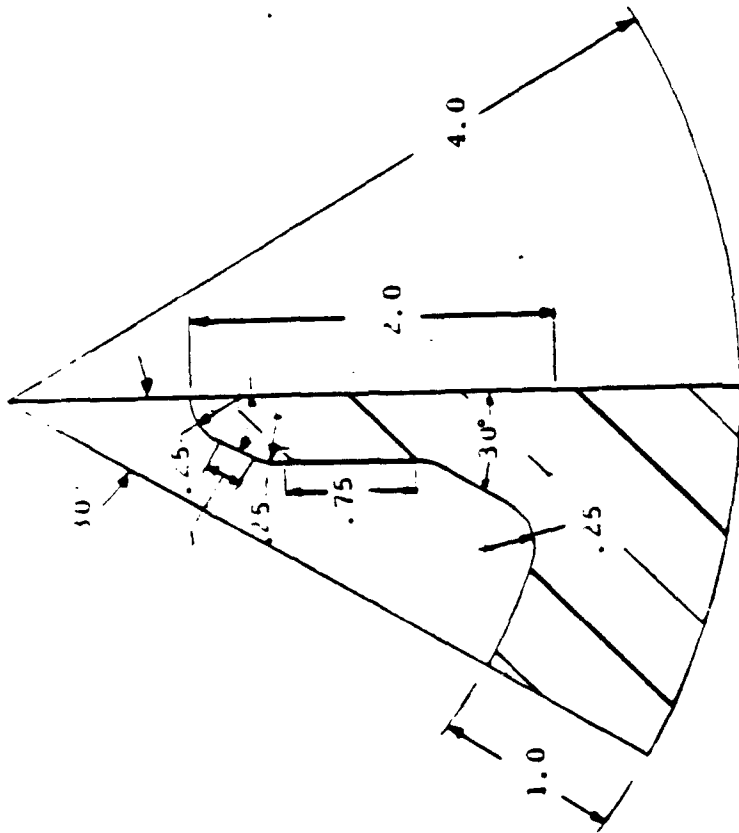

Sample Case Motor Layout

BREAKOUT OF FIRST SAMPLE CASE INPUTS

SOLID PROPELLANT ROCKET MOTOR INTERNAL
BALLISTICS PERFORMANCE ANALYSIS PROGRAM

MODIFICATION DATE - 02/04

1 0.0
EXAMPLE NUMBER 1 --- A 6 POINT STAR DESIGN
2 0.0
5/12
3 0.0

EXAMPLE NUMBER 1 --- A 6 POINT STAR DESIGN

3001	2.00000E 00	3002	2.00000E 00
3004	4.00000E 00	3005	6.00000E 00
3007	2.50000E-01	3008	2.50000E-01
3010	2.50000E-01	3014	2.00000E 00
3017	7.50000E-01	3019	3.00000E 01
3021	3.00000E 01	3024	1.00000E 00
3003	2.00000E 01	2020	0.0
3502	2.00000E 00	3101	3.50000E 00
3503	2.00000E 00	3301	4.00000E 00
3506	2.00000E 00	3801	1.75000E 00
3803	7.00000E-01	3901	4.00000E 00
3512	1.50000E 01	3513	9.60000E-01
3515	1.20000E 00	3516	5.00000E 01
3519	1.47000E 01		
3601	5.999997E-03	3602	6.00000E-01
3606	7.10000E-01	3542	1.00000E 00
6201	5.00000E-02	6102	1.00000E 00
3507	0.0	3508	9.999999E-05
3536	1.00000E 00	3521	-1.00000E 00
9000	0.0	9999	0.0

Title Cards

Prediction

3003	0.0	Description of Plane 1
3006	1.00000E 00	
3009	2.50000E-01	
3016	2.00000E-01	
3020	0.0	
3001	0.0	
3201	2.00000E 00	Description of Plane 20
3401	2.00000E 00	Head End Description
3802	9.999999E-04	Nozzle End Description
3514	6.299996E-02	Nozzle Description
3518	5.10000E 03	Propellant Physical Characteristics
3605	9.299997E-03	Propellant Burning Rate Description
6201	9.999996E-02	Time Increments
3510	1.50000E 01	Print and Stop Controls
3533	1.00000E 00	Plot Controls
		End of Input and Run

Prediction

```

PLANE NUMBER 20      CONFIGURATION TYPE = 2      RATE TYPE = 2      LENGTH = 20.000000      DIRECT INPUTS

NO      NO      TAU      Z2      Z3      Z4      Z5
0.000000 01  2.000000 01  0.100000 01  3.250000 02  0.250000 00  0.250000 00  0.250000 00
00      00      00      00      L51      L52      LA      LB
0.0      0.0      0.0      0.0      3.200000 01  0.0      0.200000 00  0.750000 00
LE      ALPHA 01      ALPHA 02      ALPHA 03      ALPHA 04      ALPHA 05      TAUS
0.0      3.100000 02  0.0      0.300000 02  0.0      0.0      0.100000 01

INITIAL PERIMETER = 0.35954020 02      INITIAL PORT AREA = 3.1093102E 02      INERT SLIVER AREA = 0.2113540E 01

***** HEAD END COORDINATES *****
RADIUS = 0.35000000 01      LENGTH = 0.20000000 01      SINE = 0.2425957E 00
***** NOZZLE END COORDINATES *****
RADIUS = 0.40000000 01      LENGTH = 0.20000000 01      SINE = 0.0
***** INITIAL VOLUMES *****
CHAMBER VOLUME      HEAD      CYLINDRICAL      NOZZLE      TOTAL
0.0044017E 02      0.1009307E 00      0.1009307E 01      3.1104326E 00
PROPELLANT VOLUME  0.3099140E 02      3.5924092E 03      0.0135000E 02      0.7041590E 03
INERT SLIVER VOLUME 0.1033500E 01      3.420472E 02      3.2113127E 01      3.0541333E 02
PORT VOLUME        0.3700317E 02      0.3700311E 03      3.3700316E 02      0.4447971E 03
INERT SLIVER CS = 10.2927

***** SCALE FACTOR INPUTS *****
SCALE FACTOR INPUTS NOT USED

***** NOZZLE DIAMETER INPUTS *****
NOZZLE CODE = 2

3T-INITIAL      KRES      KRES      KRES      3T4-EXIT
1.75000      0.100000E-02  0.700000      3.0      1.00000

***** FINE INCREMENT INPUTS *****
TIME      0.0      0.10000000 01
DELTA-TIME 0.30000000-01  0.00000000-01

***** BURNING RATE INPUTS *****
P-COEFFICIENT  P-EXPOONENT      P-CRITICAL      P-EXPOONENT      NO-COEFFICIENT      NO-EXPOONENT
3.1000000E-02  0.0000000E 00  3.0      0.0      3.9200000E-02  0.7100000E 00

***** BALLISTIC INPUTS *****
ISTAR      DENSITY      GAMMA      G-045      G1      TARP - INLET      P-ATMOS
0.110000 00  3.000000E-01  0.120000 01  3.500000 02  0.700000 03  3.150000 02  0.107000 02
POINT-START  POINT-STOP      TIME-STOP      P-STOP
3.0      3.100000E-09  0.0      3.150000 02

*** POSITIVE BURNING INPUT CONSTANTS HAVE BEEN MODIFIED TO THE FOLLOWING VALUES ***
PRESSURE(00P) = 2020.02      SCALE FACTOR = 1.00000      RATE(00P) = 0.00000
KRS = 0.000000E-01  KNS = 0.301000

***** BALLISTIC PERFORMANCE OUTPUTS *****
TIME      P-HEAD      P-STAR-NOZZLE      THROUST      MASS FLOW      TROBAT AREA      PORT AREA
3.0      3.20000E 00  0.202020E 00  0.092379E 00  3.30000E 02  0.240320E 01  0.100310E 02
INT-START  INT-STOP      INT-STOP      FUEL WEIGHT      EXIT AREA      GAS WGT. NO.
3.0      0.0      3.0      3.00000E 02  0.125000E 02  3.70357E-01
EMP. RATIO  CG      TARED      AEB      ITERATIONS      TOTAL SURFACE
3.522000 01  0.101770E 02  3.0      3.00000E 03  0      0.305000E 03

***** INTERNAL CONDITIONS AT TIME = 3.0 *****
***** HEAD END *****
TAU BURNED      RATE TYPE-0ND      RATE TYPE-INT      SCALE FACTOR      RATE-EXP.
0.0      2      2      3.100000 01  0.000000 00
STATION      SURFACE AREA      PORT AREA      FUEL VOLUME      PRESSURE      TEMPERATURE
1      3.0      3.300000 02  3.0      3.203000 00  3.000000 03
    
```

Prediction

STATION	DENSITY	VELOCITY	MASS FLOW	WACH NO.	BURNING RATE
2	0.199929E 02	0.189316E 02	0.0	0.248000E 00	3.480027E 00
3	0.199929E 02	0.189316E 02	0.0	0.248000E 00	0.480027E 00
4	0.199929E 02	0.189316E 02	0.309915E 02	0.248000E 00	3.480027E 00
STATION	DENSITY	VELOCITY	MASS FLOW	WACH NO.	BURNING RATE
1	0.390000E-03	0.0	0.0	0.0	0.000000E 00
2	0.390000E-03	0.211000E 01	0.211390E 00	0.239072E-02	0.000000E 00
3	0.390000E-03	0.211000E 01	0.211390E 00	0.239072E-02	0.000000E 00
4	0.390000E-03	0.279150E 02	0.370390E 01	0.279030E-02	0.000000E 00
***** CYLINDRICAL SECTION *****					
PLANE 1	LENGTH	TAU BURNED	PERIMETER	SURFACE AREA	PORT AREA
	0.0	0.0	0.355500E 02	0.910000E 02	0.189316E 02
	FUEL VOLUME	PRESSURE	TEMPERATURE	DENSITY	VELOCITY
	0.303915E 02	0.248000E 00	0.480027E 00	0.390000E-03	0.279150E 02
	MASS FLOW	WACH NO.	RATE EQUATION	SCALE FACTOR	BURNING RATE
	0.370390E 01	0.248000E-02	0.0	0.100000E 01	0.000000E 00
PLANE 2	LENGTH	TAU BURNED	PERIMETER	SURFACE AREA	PORT AREA
	0.109263E 01	0.0	0.355500E 02	0.120000E 03	0.189316E 02
	FUEL VOLUME	PRESSURE	TEMPERATURE	DENSITY	VELOCITY
	0.219710E 02	0.248000E 00	0.480027E 00	0.390000E-03	0.279150E 02
	MASS FLOW	WACH NO.	RATE EQUATION	SCALE FACTOR	BURNING RATE
	0.322023E 01	0.100000E-01	0.0	0.100000E 01	0.000000E 00
PLANE 3	LENGTH	TAU BURNED	PERIMETER	SURFACE AREA	PORT AREA
	0.210926E 01	0.0	0.355500E 02	0.109263E 03	0.189316E 02
	FUEL VOLUME	PRESSURE	TEMPERATURE	DENSITY	VELOCITY
	0.112750E 03	0.248000E 00	0.480027E 00	0.390000E-03	0.279150E 02
	MASS FLOW	WACH NO.	RATE EQUATION	SCALE FACTOR	BURNING RATE
	0.270000E 01	0.100000E-01	0.0	0.100000E 01	0.000000E 00
PLANE 4	LENGTH	TAU BURNED	PERIMETER	SURFACE AREA	PORT AREA
	0.315700E 01	0.0	0.355500E 02	0.203340E 03	0.189316E 02
	FUEL VOLUME	PRESSURE	TEMPERATURE	DENSITY	VELOCITY
	0.109263E 03	0.248000E 00	0.480027E 00	0.390000E-03	0.279150E 02
	MASS FLOW	WACH NO.	RATE EQUATION	SCALE FACTOR	BURNING RATE
	0.270000E 01	0.172032E-01	0.0	0.100000E 01	0.000000E 00
PLANE 5	LENGTH	TAU BURNED	PERIMETER	SURFACE AREA	PORT AREA
	0.427000E 01	0.0	0.355500E 02	0.240737E 03	0.189316E 02
	FUEL VOLUME	PRESSURE	TEMPERATURE	DENSITY	VELOCITY
	0.270000E 03	0.248000E 00	0.480027E 00	0.390000E-03	0.279150E 02
	MASS FLOW	WACH NO.	RATE EQUATION	SCALE FACTOR	BURNING RATE
	0.427000E 01	0.248000E-01	0.0	0.100000E 01	0.000000E 00
PLANE 6	LENGTH	TAU BURNED	PERIMETER	SURFACE AREA	PORT AREA
	0.520310E 01	0.0	0.355500E 02	0.270193E 03	0.189316E 02
	FUEL VOLUME	PRESSURE	TEMPERATURE	DENSITY	VELOCITY
	0.203340E 03	0.248000E 00	0.480027E 00	0.390000E-03	0.279150E 02
	MASS FLOW	WACH NO.	RATE EQUATION	SCALE FACTOR	BURNING RATE
	0.113100E 02	0.248000E-01	0.0	0.100000E 01	0.000000E 00
PLANE 7	LENGTH	TAU BURNED	PERIMETER	SURFACE AREA	PORT AREA
	0.619370E 01	0.0	0.355500E 02	0.315019E 03	0.189316E 02
	FUEL VOLUME	PRESSURE	TEMPERATURE	DENSITY	VELOCITY
	0.237000E 03	0.248000E 00	0.480027E 00	0.390000E-03	0.279150E 02
	MASS FLOW	WACH NO.	RATE EQUATION	SCALE FACTOR	BURNING RATE
	0.129307E 02	0.248000E-01	0.0	0.100000E 01	0.000000E 00
PLANE 8	LENGTH	TAU BURNED	PERIMETER	SURFACE AREA	PORT AREA
	0.710000E 01	0.0	0.355500E 02	0.359050E 03	0.189316E 02
	FUEL VOLUME	PRESSURE	TEMPERATURE	DENSITY	VELOCITY
	0.203340E 03	0.248000E 00	0.480027E 00	0.390000E-03	0.279150E 02
	MASS FLOW	WACH NO.	RATE EQUATION	SCALE FACTOR	BURNING RATE
	0.102077E 02	0.248000E-01	0.0	0.100000E 01	0.000000E 00
PLANE 9	LENGTH	TAU BURNED	PERIMETER	SURFACE AREA	PORT AREA
	0.802100E 01	0.0	0.355500E 02	0.403081E 03	0.189316E 02
	FUEL VOLUME	PRESSURE	TEMPERATURE	DENSITY	VELOCITY
	0.290070E 03	0.248000E 00	0.480027E 00	0.390000E-03	0.279150E 02
	MASS FLOW	WACH NO.	RATE EQUATION	SCALE FACTOR	BURNING RATE
	0.130791E 02	0.248000E-01	0.0	0.100000E 01	0.000000E 00
PLANE 10	LENGTH	TAU BURNED	PERIMETER	SURFACE AREA	PORT AREA
	0.907500E 01	0.0	0.355500E 02	0.447112E 03	0.189316E 02
	FUEL VOLUME	PRESSURE	TEMPERATURE	DENSITY	VELOCITY
	0.331007E 03	0.248000E 00	0.480027E 00	0.390000E-03	0.279150E 02
	MASS FLOW	WACH NO.	RATE EQUATION	SCALE FACTOR	BURNING RATE
	0.170000E 02	0.248000E-01	0.0	0.100000E 01	0.000000E 00
PLANE 11	LENGTH	TAU BURNED	PERIMETER	SURFACE AREA	PORT AREA
	0.109263E 02	0.0	0.355500E 02	0.491143E 03	0.189316E 02
	FUEL VOLUME	PRESSURE	TEMPERATURE	DENSITY	VELOCITY
	0.302100E 03	0.248000E 00	0.480027E 00	0.390000E-03	0.279150E 02
	MASS FLOW	WACH NO.	RATE EQUATION	SCALE FACTOR	BURNING RATE
	0.102110E 02	0.248000E-01	0.0	0.100000E 01	0.000000E 00

Prediction

PLANE 16	LENGTH 3.15700E 02	TAU BURNED 3.0	PERIMETER 3.35594E 02	SURFACE AREA 3.65249E 03	PORT AREA 3.16531E 02
	FUEL VOLUME 3.51800E 03	PRESSURE 3.24259E 04	TEMPERATURE 3.27461E 04	DENSITY 3.37066E-03	VELOCITY 3.20099E 03
	MASS FLOW 3.26521E 02	MACH NO. 3.35302E-01	RATE EQUATION 3.10000E 01	SCALE FACTOR 3.10000E 01	BURNING RATE 3.66472E 00
PLANE 17	LENGTH 3.16642E 02	TAU BURNED 3.0	PERIMETER 3.35594E 02	SURFACE AREA 3.66937E 03	PORT AREA 3.16531E 02
	FUEL VOLUME 3.54920E 03	PRESSURE 3.24249E 04	TEMPERATURE 3.27470E 04	DENSITY 3.37042E-03	VELOCITY 3.21212E 03
	MASS FLOW 3.28040E 02	MACH NO. 3.34970E-01	RATE EQUATION 3.10000E 01	SCALE FACTOR 3.10000E 01	BURNING RATE 3.66499E 00
PLANE 18	LENGTH 3.17847E 02	TAU BURNED 3.0	PERIMETER 3.35594E 02	SURFACE AREA 3.72735E 03	PORT AREA 3.16531E 02
	FUEL VOLUME 3.58064E 03	PRESSURE 3.24239E 04	TEMPERATURE 3.27470E 04	DENSITY 3.36917E-03	VELOCITY 3.22370E 03
	MASS FLOW 3.29587E 02	MACH NO. 3.34170E-01	RATE EQUATION 3.10000E 01	SCALE FACTOR 3.10000E 01	BURNING RATE 3.66380E 00
PLANE 19	LENGTH 3.18847E 02	TAU BURNED 3.0	PERIMETER 3.35594E 02	SURFACE AREA 3.78673E 03	PORT AREA 3.16531E 02
	FUEL VOLUME 3.61821E 03	PRESSURE 3.24222E 04	TEMPERATURE 3.27470E 04	DENSITY 3.36939E-03	VELOCITY 3.23300E 03
	MASS FLOW 3.31074E 02	MACH NO. 3.33490E-01	RATE EQUATION 3.10000E 01	SCALE FACTOR 3.10000E 01	BURNING RATE 3.66349E 00
PLANE 20	LENGTH 3.20000E 02	TAU BURNED 3.0	PERIMETER 3.35594E 02	SURFACE AREA 3.82157E 03	PORT AREA 3.16531E 02
	FUEL VOLUME 3.64280E 03	PRESSURE 3.24209E 04	TEMPERATURE 3.27471E 04	DENSITY 3.36932E-03	VELOCITY 3.24497E 03
	MASS FLOW 3.32944E 02	MACH NO. 3.32859E-01	RATE EQUATION 3.10000E 01	SCALE FACTOR 3.10000E 01	BURNING RATE 3.66344E 00
***** WZZLE END *****					
	TAU BURNED 3.0	RATE TYPE=INT 2	RATE TYPE=INT 2	SCALE FACTOR 3.10000E 01	FARE=EXP. 3.664152E 00
STATION 1	SURFACE AREA 3.62119E 03	PORT AREA 3.18531E 02	FUEL VOLUME 3.64480E 03	PRESSURE 3.24200E 04	TEMPERATURE 3.27471E 04
2	3.67247E 03	3.18531E 02	3.70415E 03	3.24184E 04	3.27465E 04
3	3.87126E 03	3.18531E 02	3.70415E 03	3.24184E 04	3.27465E 04
4	4.90900E 03	3.30285E 02	3.70415E 03	3.24250E 04	3.27477E 04
STATION 1	DENSITY 3.34910E-03	VELOCITY 3.24400E 02	MASS FLOW 3.32500E 02	MACH NO. 3.34810E-01	BURNING RATE 3.66344E 00
2	3.34810E-03	3.24240E 02	3.35510E 02	3.34337E-01	3.66160E 00
3	3.34810E-03	3.24240E 02	3.35510E 02	3.34337E-01	3.66160E 00
4	3.34810E-03	3.10284E 02	3.36800E 02	3.28350E-01	3.66414E 00
TIME 3.50000E-01	P=HEAD 3.22719E 04	P-STAG-WZZLE 3.22647E 04	T=HAUST 3.25240E 04	MASS FLOW 3.35292E 02	T=PORT AREA 3.24700E 01
	INF=PORT 3.12314E 03	INF=PORT 3.11970E 03	IMPULSE 3.44540E 03	FUEL WEIGHT 3.42520E 02	EXIT AREA 3.12500E 02
	EXP. RATIO 3.13074E 01	CG 0.10170E 02	TAUSD 0.31500E-01	ASED 0.40607E 03	ITERATIONS 3
TIME 3.12332E 00	P=HEAD 3.21339E 04	P-STAG-WZZLE 3.21271E 04	T=HAUST 3.41824E 04	MASS FLOW 3.33999E 02	T=PORT AREA 3.27525E 01
	INF=PORT 3.23240E 03	INF=PORT 3.23100E 03	IMPULSE 3.47131E 03	FUEL WEIGHT 3.40754E 02	EXIT AREA 3.12500E 02
	EXP. RATIO 3.44618E 01	CG 0.10170E 02	TAUSD 3.41900E-01	ASED 3.70600E 03	ITERATIONS 2
TIME 3.15000E 00	P=HEAD 3.20092E 04	P-STAG-WZZLE 3.20032E 04	T=HAUST 3.78001E 04	MASS FLOW 3.32859E 02	T=PORT AREA 3.25912E 01
	INF=PORT 3.13761E 03	INF=PORT 3.13670E 03	IMPULSE 3.12793E 04	FUEL WEIGHT 3.34059E 02	EXIT AREA 3.12500E 02
	EXP. RATIO 3.44490E 01	CG 0.10181E 02	TAUSD 0.31172E-01	ASED 3.90972E 03	ITERATIONS 2
TIME 3.20000E 00	P=HEAD 3.19047E 04	P-STAG-WZZLE 3.18994E 04	T=HAUST 3.76023E 04	MASS FLOW 3.31700E 02	T=PORT AREA 3.22910E 02
	INF=PORT 3.43722E 03	INF=PORT 3.4349E 03	IMPULSE 3.17614E 04	FUEL WEIGHT 3.17614E 02	EXIT AREA 3.12500E 02
	EXP. RATIO 3.47590E 01	CG 3.10183E 02	TAUSD 0.31942E 00	ASED 3.90672E 03	ITERATIONS 1
TIME 3.25000E 00	P=HEAD 3.18042E 04	P-STAG-WZZLE 3.17994E 04	T=HAUST 3.73303E 04	MASS FLOW 3.30774E 02	T=PORT AREA 3.27092E 01
	INF=PORT 3.51143E 03	INF=PORT 3.5092E 03	IMPULSE 3.20521E 04	FUEL WEIGHT 3.15855E 02	EXIT AREA 3.12500E 02
	EXP. RATIO 3.46100E 01	CG 3.10184E 02	TAUSD 3.14079E 00	ASED 3.90699E 03	ITERATIONS 2
TIME 3.30000E 00	P=HEAD 3.17140E 04	P-STAG-WZZLE 3.17100E 04	T=HAUST 3.70970E 04	MASS FLOW 3.29800E 02	T=PORT AREA 3.27640E 01
	INF=PORT 3.62327E 03	INF=PORT 3.61819E 03	IMPULSE 3.24180E 04	FUEL WEIGHT 3.14280E 02	EXIT AREA 3.12500E 02
	EXP. RATIO 3.45644E 01	CG 3.13100E 02	TAUSD 3.17323E 00	ASED 3.90600E 03	ITERATIONS 2

Prediction

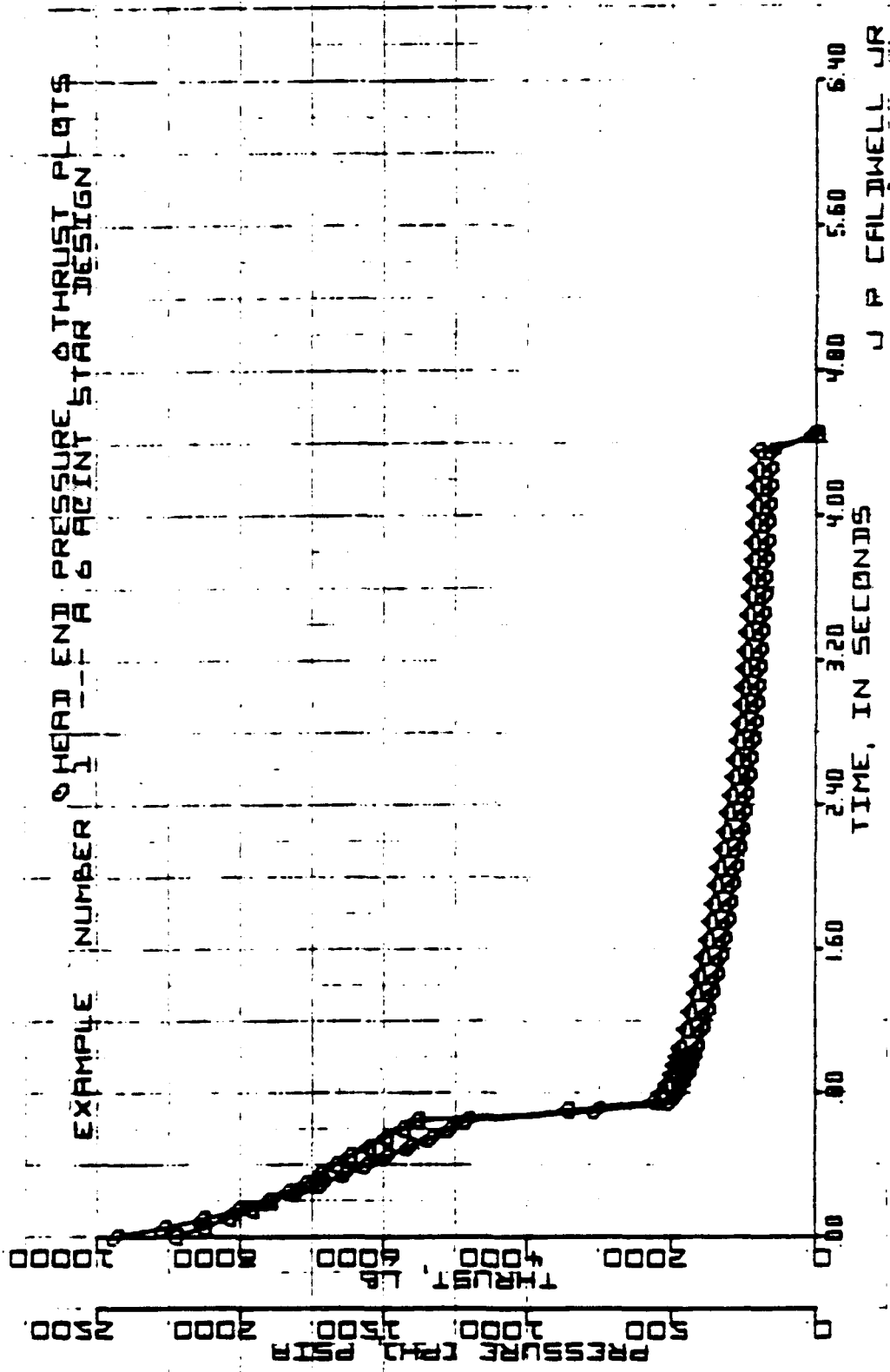

Sample Case Resulting Performance Plot

CHAPTER XI TESTING

There are many reasons for testing physical systems. The purposes of a test data collecting program may be any or all of the following:

- (1) to measure the correctness and completeness of the design
- (2) to evaluate the performance of the system
- (3) to verify system improvement
- (4) to uncover system defects at an early stage and check manufacturing process
- (5) to increase understanding of system operation
- (6) to determine data for new design
- (7) to determine data for improved design
- (8) to perform integrated controls analysis
- (9) to confirm theoretical calculations
- (10) to predict useful life.

It is generally necessary to carry out careful measurements to accomplish these purposes. In conducting experimental work on engineering prototypes, these are the common goals continually sought. Depending on the field of application, these goals and similar measurements are critical indicators of competitive position or even the success of an engineering design. Obviously, application of the measurement equipment associated with such evaluations is extensive in scope.

Preparation for testing includes laying down the theoretical basis for the system parameter to be tested and selecting the appropriate test methods. The test method depends upon three principal factors: the theory of operation of the system to be tested, the available equipment and facilities resources, and the methods available to evaluate and interpret the final data. Expected data types have to be determined before testing so that the unique characteristics of each can be recorded in a proper manner with minimum loss and error. At this point it is worthwhile to separate the quantities that can be measured into one of three categories: static, dynamic, and transient response. This helps to determine the sensitivities, usable range of variables, levels of uncertainty, accuracies, limitations, and other response of the equipment required to perform the testing measurements. When tests are thus refined at the planning stage, it is possible to evaluate data more exactly to give greater confidence to the validity of the data and the relationships established between the system or process variables. Such additional refinements in test methods can produce information that may well lead to reexamination of previously considered second order effects that prove not to be negligible.

The testing procedure that is almost universally followed consists of the following steps:

- (1) planning the tests
- (2) selecting the test equipment
- (3) conducting the tests
- (4) analyzing recorded data.

The test planning is governed by the purpose of the test and should define the input and output variables for the system. Limitations imposed by the nature of the experimental measurement are those imposed by the theory, capabilities of the systems, and quantities that are incapable of being measured. The latter may occur either because of lack of knowledge of the physical theory or the technology has not uncovered a practical method.

Interpretation of the data depends not only on the engineer's experience in performing tests but also on his understanding of the test and the instrumentation capabilities and limitations.

Testing

Testing is necessary to evaluate rockets and missiles (including components) in an environment equivalent to that found in field use. Many different tests, using various techniques, are performed during the development and production of a missile system. Generally, these tests fall into two categories: nondestructive and destructive.

11.1 Nondestructive Tests

Nondestructive testing can determine the integrity of a particular unit or part quite inexpensively without rendering it useless. Specimens tested by destructive test methods usually become bent, twisted, notched, chipped, or broken during the testing and are worthless for further use. Nondestructive testing avoids this limitation. The following briefly describes some of the nondestructive tests currently being conducted. Each method has capabilities and limitations qualifying it for specific uses. In each case, it is necessary to analyze the particular specimen to determine which method will best obtain results. In some instances, more than one method may be required to assess the quality of the part or unit.

Visual Inspection and Measurement of Samples

Propellant grains are visually inspected to detect defects and abnormalities. In addition, samples of the grains are measured for conformity to standards. These simple tests have revealed conditions and changes in the items that explained erratic and abnormal performance in subsequent testing. Examples of conditions revealed are:

- (1) unbonded inhibitors
- (2) grain shrinkage
- (3) inhibitor delaminations.

Radiographic Inspection

Most materials can be X-rayed. The internal nature of the material is revealed and a permanent record of the test specimen is provided on film. Structural discontinuities and fabrication errors are disclosed and necessary corrective action is often indicated.

Propellant grains and loaded motors are X-rayed to detect interior breaks, cracks, inclusions, porosity, unbondedness, fissuring and nonhomogeneity in the propellant, and improper loading of the motor.

Examples of these defects are:

- (1) porosity in cast propellants
- (2) unbondedness in 40-pound charge grains
- (3) missing O-rings
- (4) broken ignition leads.

Ultrasonic Inspection

Using this type of testing, units can be inspected that are accessible from only one side. In some cases this is an advantage over X-ray techniques. In most cases, it is also less expensive. In a test of

Testing

this type, high frequency sound waves are directed into the part and are reflected from discontinuities within. Reflected sound waves are picked up and displayed on an oscilloscope screen. Such defects as cracks, inclusions, and unbonded conditions are seen readily. In many cases, their sizes and orientations can be discerned. Good contact must be maintained between the probe (sound wave producer) and the part to be tested. A coupling liquid which is usually an oil or water is applied to the surface to carry the sound into the part and is wiped off after the test has been completed.

Dye Penetrant Inspection

Through the use of dye penetrants, surface flaws, such as cracks, folds, and porosity, which are ordinarily too small to be observed visually, can be observed. A limiting factor is that the part to be tested must be of a normally nonporous material. The part is cleaned thoroughly and then sprayed with a fluorescent dye. After the dye has been allowed to penetrate into specimen's cracks, the part is wiped clean. The dye remains in the cracks to be brought out by a developer (blotter) spray. Under a black light, indications of cracks appear as thin lines on the dark blotter background. The equipment for this type of testing consists of only three aerosol spray cans and a black light and therefore is very portable.

Magnetic Particle Inspection

Cracks on or near the surface of a particular part can be found using magnetic particle testing. For large steel objects on which small surface defects are suspected, this method is ideal, however, the part must be capable of being magnetized.

A magnetic field is applied to magnetize the part and black iron powder is sprinkled on it. The powder congregates along discontinuities because of the shape and greater strength of the magnetic field produced at these points. This method is simple and inexpensive and the results are easily interpreted. When greater sensitivity is required, fluorescent particles, suspended in a liquid stream, are directed on the part. Again, the particles collect on a discontinuity so that under a black light cracks and other discontinuities show up very well.

Temperature Conditioning and Cycling

Cycling tests are conducted to determine resistance to temperatures that may be encountered during storage or service use. Temperatures may range from -65 degrees to 165 degrees F. Observations are made on grain cracking, inhibitor unbondedness and delamination, migration of nitroglycerin and plasticizers, and the permanent set or cracking of seal rings and O-rings.

Sand and Dust

These tests are conducted to determine resistance to blowing fine sand and dust particles which, because of their abrasive character, can affect items having moving parts (such as the safe-arm mechanism of igniters).

Testing

Jolt and Jumble

Jolt and jumble tests are conducted to determine the effects on small items such as igniters to an environment expected in handling and transportation.

Shock (Mechanical)

Tests are conducted to determine that the structural integrity and performance of an item are satisfactory with respect to the mechanical shock environment expected in handling, transportation, and service use.

Humidity

Items are subjected to high humidity, usually in conjunction with high temperature conditioning tests, to determine their sensitivity to moisture and the type and degree of deterioration that occur. Items containing hygroscopic materials are of particular concern.

Fungus

Fungi secrete enzymes that destroy most organic and mineral substances. By utilizing a fungus chamber to study the resistance of propellants and their associated rocket motors to these enzymes, the enzymatic effect on weapon systems and components can be determined.

Vibration

Items are vibrated to determine that they are constructed to withstand expected dynamic stresses at pronounced resonant frequencies and that performance degradations or malfunctions will not be produced by the service vibration environment.

Acceleration

Inertially-armed devices are tested on a centrifuge to determine conformance to specification requirements under various g-levels.

Drop

Drops of up to two feet can be considered nondestructive tests. Units subjected to this test are dropped onto a steel plate embedded in reinforced concrete. Using normal firing procedures, the dropped units are then static fired with the expectation that they will perform satisfactorily.

Salt Spray

Tests are conducted to determine the resistance of equipment to the effects of a salt atmosphere. Areas of primary concern are paint fading, metal corrosion, and deterioration of natural rubber and plastic components.

Testing

Rain

These tests are conducted to determine the effectiveness of rocket motors and related components after exposure to 40-mile-per-hour, windblown rain.

11.2 Destructive Tests

In many cases, destructive tests are the only valid tests available to analyze a particular specimen. As mentioned previously, specimens subjected to these types of tests are worthless for further use. In general, the specimens destroyed are considered to be a representative sampling of items. If the data from test specimens meet the necessary requirements, the remaining items of the group can be used as designed with a degree of confidence. Typical destructive tests are described in the following paragraphs.

Mechanical Properties

The mechanical properties of propellants are determined by the use of conventional tensile testing equipment. Test specimens, which are machined from the propellant grains and are usually in the form of dumbbells or dog bones, are pulled over a range of temperatures. The load-deformation curve is recorded for each test. The data developed include stress, elongation, and modulus. Results of the tests are used in production control and acceptance of solid propellants.

Strand Burning

Strands or straws filled with liquid or cast propellants are used to determine the burning rates of propellants over a wide range of pressures and temperatures, i.e., up to 8000 psi and from -65° to 250° F. This test is used in evaluating new propellant formulations and for production control and acceptance of propellants.

Partial Burning

On occasion, rocket motors have been partially burned to determine the burning pattern of solid propellant grains and to identify the cause of abnormalities noted in other firings. The motor is mounted vertically, ignited, and after a preselected time the head closure is released to permit the unsecured components within the motor to fall into a water tank. Examination of the extinguished propellant grain can reveal irregular burning, pitting, and abnormal erosion. This is primarily an investigative test.

Static Firings

Static firings are performed on test, experimental, and developmental type motors, and service motors. These test specimens include igniters, gas generators, ejection catapults, cartridge-actuated devices, and rocket motors. The unit is secured to the firing block and instrumented for internal pressure, thrust, and temperature. Data are recorded by a variety of methods, which include oscillograph traces and magnetic tape.

Testing

Centrifuge Firings

In the service firing of a missile containing a gas generator for guidance and control, the gas generator is initiated prior to missile launch. With the firing of the propulsion unit, the burning surface of the gas generator is subjected to high acceleration loads that may affect its gas output. For this reason, some items, principally gas generators, have been fired on the ballistic centrifuge under conditions of high acceleration. Units can be instrumented for internal pressure, temperature. Data are recorded by oscillographs.

Drop Test

The 40-foot drop test is a safety test to determine whether the propulsion unit will withstand a severe handling mishap without igniting or detonating. It is not intended that the unit be serviceable after this drop.

Chemical Analysis

Chemical analysis consists primarily in testing, analyzing, and evaluating propellant ingredients, propellants in-process, finished products, and related end items for their chemical, physical, and stability properties. This type of testing is designed to assure safety and quality control throughout the manufacturing process and during the distribution and use of the end item. Tests may vary from quantitative assay to determination of trace impurities, alloy composition analysis and verification, and physical properties determination and measurement (e.g., viscosity, ignition point, freezing and/or melting point, and heat of explosion or energy content). Such testing involves classical wet chemistry procedures augmented by highly-specialized instrumentation techniques, e.g., gas chromatography, electrochemistry and infrared, ultraviolet, optical emission, X-ray, and nuclear magnetic resonance spectroscopy.

Metallurgical Properties

Metallurgical tests are conducted on propellant processing equipment and inert rocket motor parts to ensure that their mechanical, physical, and chemical properties agree with those specified on their respective part drawing. The mechanical properties determined are tensile, shear, impact, fatigue, and macro- and micro-hardness. The physical properties determined are uniformity in microstructure, grain size, cleanliness, and absence of defects. The chemical properties determined are confined to chemical composition and corrosion resistance.

Test System Components

Motors are designed to operate under certain conditions. They are static-fired during the development, production, and surveillance phases to find if they actually do what they are supposed to do. In the development phase, test trouble can be expected at any time.

Units in the production phase are tested in accordance with established statistical sampling techniques to determine whether production was carried out properly. Surveillance programs, also using statistical sampling methods to reveal time-related changes in performance and especially to

Testing

detect drifts toward submarginal operation (which occurs at the end of useful life) or, more serious, trends toward dangerously anomalous behavior (which ends safe life).

Measurement of ballistic parameters (especially thrust and pressure as a function of time) is now highly developed technology, and improvements are being made rapidly.

A static-test system schematic is shown below. It should be apparent that the accuracy of the resulting measurements depends on the accuracy of all components in the chain of signal flow. Components contributing to errors may include the following:

- (1) Motor, stand, and linkages (misalignment, lack of freedom of axial movement, etc.)
- (2) Transducer (clogged pressure transducer)
- (3) Transmission wires (too far between stand and data recording equipment)
- (4) Recording equipment (faulty calibration)
- (5) Data reduction activities (in the measurement of the pressure or thrust-time integral by hand, as in the old method).

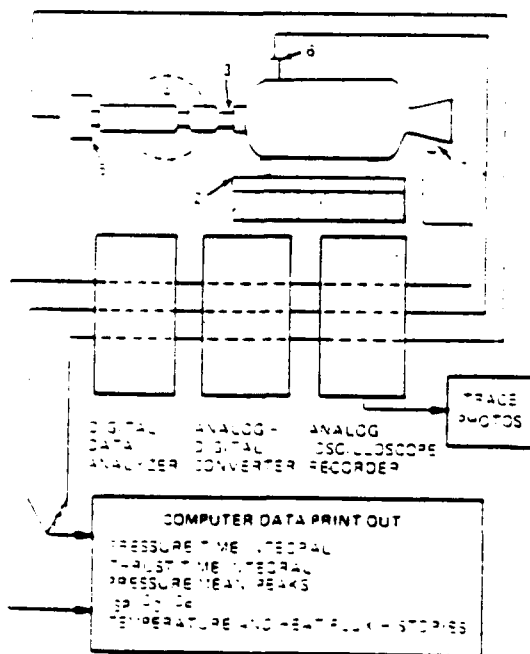

- 1 TEST BLOCK (REINFORCED CONCRETE)
- 2 MOTOR SUSPENSION CARRIAGE
- 3 UNIVERSAL JOINT TO REMOVE NONAXIAL FORCES
- 4 PRECISION MECHANICAL THRUST TRANSMITTING LINKAGE (AEROSPACE STAND)
- 5 THRUST TRANSDUCER (STRAIN GAGE)
- 6 PRESSURE TRANSDUCER (STRAIN GAGE)
- 7 TEMPERATURE TRANSDUCER (THERMOCOUPLE)

TEST SYSTEM COMPONENTS

Testing

A representative matrix of test conditions (destructive and non-destructive) is presented on the following two pages. As you can see, tests are often piggy-backed to reduce the required number of test articles.

Newer weapons and rockets require greater precision in measurements for the following reasons:

- (1) Design margins and tolerances are shrinking as designers try to meet more stringent requirements
- (2) Greater attention is being paid to minor effects as clues to malfunction causes and to long-term storage changes.

MQM-107 JATO

Testing

TEST	13	14	15	16	17	18	19	20	21	22	23	24	25
HIGH TEMP STORAGE	a	a	a	a									
THERMAL SHOCK	b	b			a	a	a	a	a				
VIBRATION	c				b								
	-65°F												
	160°F	c				b							
HUMIDITY							b	b	b				
ALTITUDE							c	c	c				
DUST							d	d	d				
RAIN							e	e	e				
SALT FOG							f	f	f				
FOUR FOOT DROP							g	g	g				
	-65°F												
	70°F												
	160°F												
TEMP GRADIENT										a			
	-40°F												
	140°F										a		
BALLISTIC													
	-40°F	d			b	c	h	h	h	b			
	70°F												
	140°F												
CONTINGENCY		d			b	c			h				a
													a

MQM-107 JATO QUALIFICATION/SAFETY TEST MATRIX

TEST	TEMP.	1	2	3	4	5	6	7	8	9	10	11	12
SLOW COOK OFF		a	a										
NON-PROPULSIVE				a	a								
INSULATION*						a	a						
BALLISTIC	-40°F							a	a				
	70°F								a	a			
	140°F										a	a	a
CONTINGENCY													

Testing

*THIS TEST HAS BEEN REPLACED BY USE OF AN INSTRUMENTED INERT MOTOR PER FLIGHT TEST PLAN

11.3 Instrumentation

Composition of Measuring Systems

Although the eyes are excellent and reliable for reading dials and gauges, they react too slowly to follow the readings of rapidly changing quantities. For high-speed measurements, both the measured variable and the reference quantity must be transformed into a signal suitable for processing and recording. This is also true when the quantities to be measured are very weak or remotely located or when many sources must be recorded simultaneously. In modern engineering work, many measurements formerly performed and interpreted manually are now, by necessity, handled by automatic data recording systems. In addition to the recording device needed for high-speed measurement, very small physical quantities need two or more stages of transformation: first, into a suitable intermediate quantity that can be readily amplified and, second, raised to a power level high enough to operate a suitable recording means. The simplest measuring systems consist basically of three functional units. They are the transducer or **primary detector**, the intermediate means or **signal conditioner**, and the **recorder** or indicator. Exact definitions of these terms vary with the observer, but in general, the following are the ones commonly accepted. More elaborate systems include automatic data processing and computation equipment.

Primary Detector

A primary detector (transducer) is the first system element or group of elements to respond to the physical property or condition that is to be measured.

Signal Conditioner

The intermediate means, where necessary, adapts the operational results of the primary detector to the input requirements of the end device. It consists of those elements necessary to receive the output signal from the primary detector and prepare it for ready acceptance by the recording device used.

Many functions are included in this block. The complexity and type of intermediate converter used are dictated by the type of output of the prime detector with which it must deal. For example, with transducers that produce a series of pulses, an integrating action is desirable for analog indication so that a voltage is produced that is proportional to the pulse repetition rate, thus providing a measurement proportional to the variable. For transducers that produce a tiny output voltage, high-gain amplification is usually needed. In all cases the intermediate means is selected to make compatible both the primary detector, or sensing means, and the readout device. It also may be a device for converting an analog signal into a coded digital form for recording by digital means. In this application it is called simply an analog-to-digital converter or digitizer. The intermediate means then may be an amplifier, digitizer, bridge balance, frequency converter, demodulator, or other similar apparatus. It may be necessary that more than one type of intermediate means is required for a specific measurement.

Recorder or Indicator

An end device, the recorder or indicator is the final system element that responds quantitatively and performs the final conversion of measurement energy to an indication, record, or the initiation of control.

Testing

The end device provides the means of indicating or recording the data sensed by the primary sensor and altered by the intermediate means. The readout may be an analog or digital indication or recording. Analog indicators take such form as panel meters, null balance indicators, gauges, thermometers, and manometers. Digital indicators may consist of numbered drum devices, lighted number banks, neon lamp displays, and others. Analog recorders are in the form of strip chart or circular chart recorders and null balance potentiometers, direct writing and photograph oscillographs, X-Y plotters, and magnetic tape recorders. Digital recording systems may produce punched paper tape, punched cards, or coded pulse magnetic tape.

Data Handling

The concept of a data handling system involves not only the sensing and transmission of data information but also the reduction or final processing and computing function. Automatic methods are used when manual methods are too slow, cumbersome, or expensive. The initial phase of sensing and transmitting data information is called data acquisition, which has been discussed previously. Taken together, the processing and computation of scientific test data are considered as data reduction.

Data processing means the conversion of information in order to present it for visual evaluation, followed by the final encoding of the data for presentation in a form suitable for computation. At this point, recording is required either for permanent record or as a storage means prior to computation. Typical recorders may be magnetic tape recorders, oscillographs, plotters, tabulators, or punched cards or tapes. Equipment to observe the information stored in any of these forms is necessary, either for presentation of data or to provide means for selection of that portion of the acquired data which is to be further processed by computation. Digital data processing includes sampling, conversion, and storage of data in digital form prior to computation. This type of processing is growing rapidly in acceptance because it provides the only realistic way to handle the vast amounts of information acquired during testing at the rate that modern digital computers are capable of performing the necessary computations. Once information is put into digital form, there is a significant improvement in the ratio of extraneous noise to the desired signal and no data are lost through transmission, attenuation, and interference pickup. Digital systems are usually more costly and complex, however, and require a high level of maintenance. Nevertheless, to process large amounts of data quickly, such systems do permit development testing at a faster pace and with shorter development cycles.

The term computation refers to reading the data previously processed, and by combining them or comparing them with known functions, arriving at new or computed values. These values may then be read out or recorded in final computed form as a plot, tabulated column of figures, a group of punched cards or tapes, or signals on magnetic tape. It is possible to feed data information directly to a computer, bypassing the intermediate storage form. This is called "real time" or "on-line operation." To decrease the amount of time involved in assessing the records, automatic systems have been designed. A typical one is the Digital Internal Ballistic Analyzer (DIBA).

System Description

The DIBA measures desired parameters during static tests and presents the measurements in digital form immediately after completion of the test. These data are displayed in reduced form on decimal-coded counters. Analog signals are available which permit recording of curves represent-

Testing

ing both pressure and thrust-time functions. Parameters that are measured and reduced to digital form include the pressure-time and thrust-time integrals, propellant burning time, ignition delay time, and maximum pressures for two preselected time intervals.

A typical pressure versus time curve for a solid propellant rocket motor is given below.

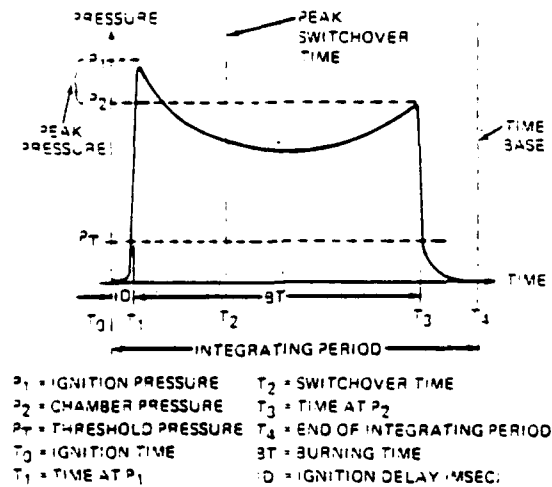

The printed data from the DIBA are defined as follows:

- (1) Ignition time delay (ID) – The interval between the ignition fire pulse and the time the reaction pressure reached the preset threshold pressure, P_t
- (2) Propellant burning time (BT) – Interval between the time the reaction pressure rises to P_t until the reaction pressure drops back to P_t
- (3) Pressure-time integral ($\int P dt$) – Reaction pressure is integrated by gating the counter over the period from the ignition fire pulse to the end of the preselected time-base interval
- (4) Thrust-time integral ($\int F dt$) – Thrust is integrated by gating the counter over same interval as the reaction pressure counter
- (5) Peak pressure one (P_1) – Maximum reaction pressure occurring during the interval between the ignition fire pulse and the preselected switchover time. This is the initial peak pressure (ignition pressure).
- (6) Peak pressure two (P_2) – Maximum reaction pressure occurring during the period from the switchover time to the end of the time-base interval. This is the final peak pressure (chamber pressure).

Testing

AUTOMATIC DATA ACQUISITION SYSTEM

System Description

The Automatic Data Acquisition System (ADA)/computer complex constitutes an integrated system designed to monitor and control solid-propellant motor tests, to record data, and to process the data to obtain useful information. A portion of the data can be analyzed "on-line" during firing depending on the specific requirements of the tests. This system practically eliminates manual assessment of data and speeds up the acceptance testing of motors. The ADA system is composed of three basic sections: the analog data section, the digital data system, and the control panels of the console. Under direction of the operator at the console, commands and controls are sent to the test site, data system, and computer.

The engine under test is equipped with transducers such as strain gauges and thermocouples (see figure below). The signals from the transducers are brought over cables to the analog data acquisition section of the ADA. In this section, these signals are conditioned, amplified, and recorded in analog form. The amplified signals are also sent through a digitizing system which samples each of the many channels in a programmed sequence and converts the analog voltages to digital data which can be recorded with high accuracy. These data are recorded on digital tape and are also sent to the computer where they are evaluated. The entire data system is controlled from the console, which also controls the computer and test site and synchronizes them with the data system. The system can be used "on-line" during actual performance of a test. In this case, the ADA system controls and monitors the calibration, countdown, and actual testing procedure. The system is also used "off-line" in the analysis of the information which has been recorded during the course of the test.

11.4 Data Analysis

The design engineer's job is not over when the fire button is pushed on the test console. This is by far the most nerve racking portion of a motor development, for during the next few seconds, the success (or failure) of perhaps a year's work will be demonstrated. No amount of planning, preparation, and sound engineering can totally remove the queasiness you feel in your stomach. At the instant the button is pushed, you see a bright flash from the nozzle and hear the roar of the exhaust. Then, in seconds, it's all over. Our question shifts from "Will it work?" to "How well did it work?" To answer this, we pour over the data that were taken during the firing.

MQM-107 JATO TEST DATA ACQUISITION SYSTEM

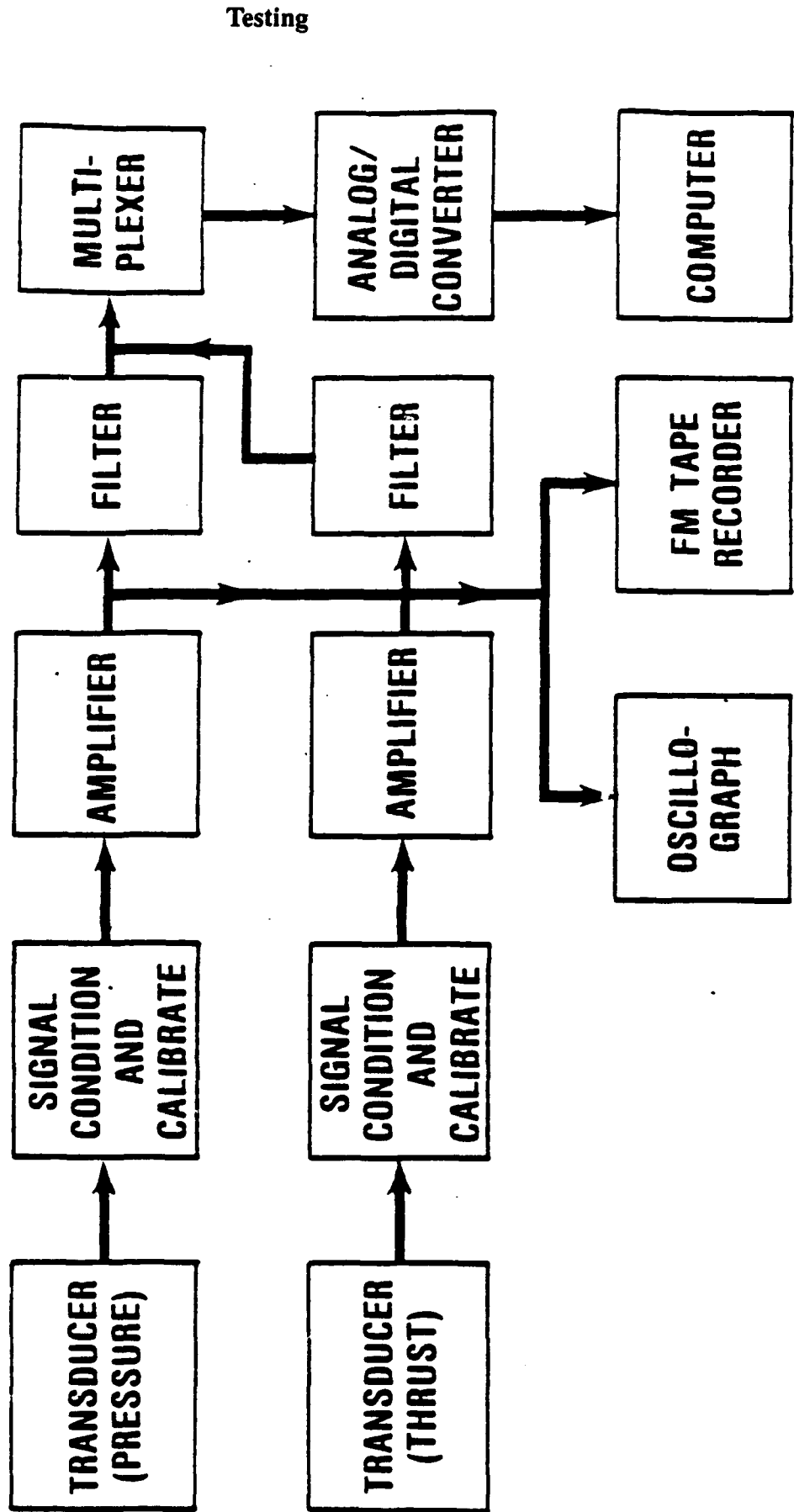

MQM-107 JATO BALLISTIC TEST SET-UP

Testing

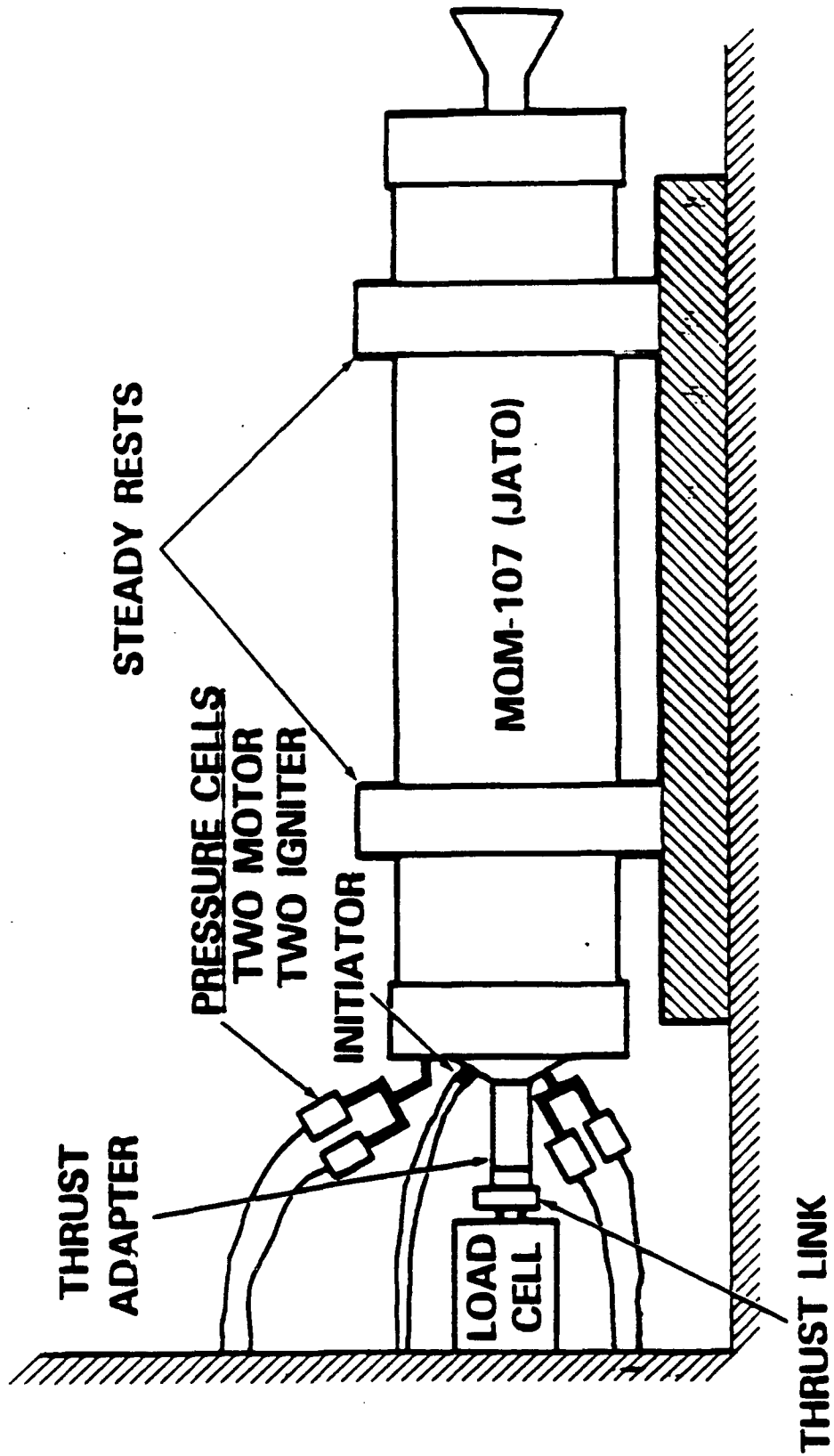

Testing

While the motor was operating, pressure, thrust, and temperature measurements were being made and the information was being stored. Post-fire computer analysis results in tabulated and plotted data for the engineer to review. The figure below is a thrust and pressure history for the HY-DRA-70 or 2.75" rocket motor.

After the test is over, the engineer compares the measured performance to the predicted performance. If all has gone well, the comparison is quite close. Often, however, the actual and predicted curves differ. Reasons for the difference must be established to determine if the computer simulation was in error or whether there is a problem with the motor itself. This can be a very challenging and difficult task, particularly when the predicted and actual performance differ greatly (see the second figure below). The remaining motor hardware must be inspected for clues to the problem. Physical evidence is often found which explains the cause of the problem. Often however, no physical clues can be found and the analyst must systematically vary parameters in the prediction model to try to simulate the observed performance. Very few "rules of thumb" exist for investigating problems. Each situation has its own peculiarities and the engineer has to play detective.

Testing

3812 MK 80-0 IH84E001-010 S/N 14 150F

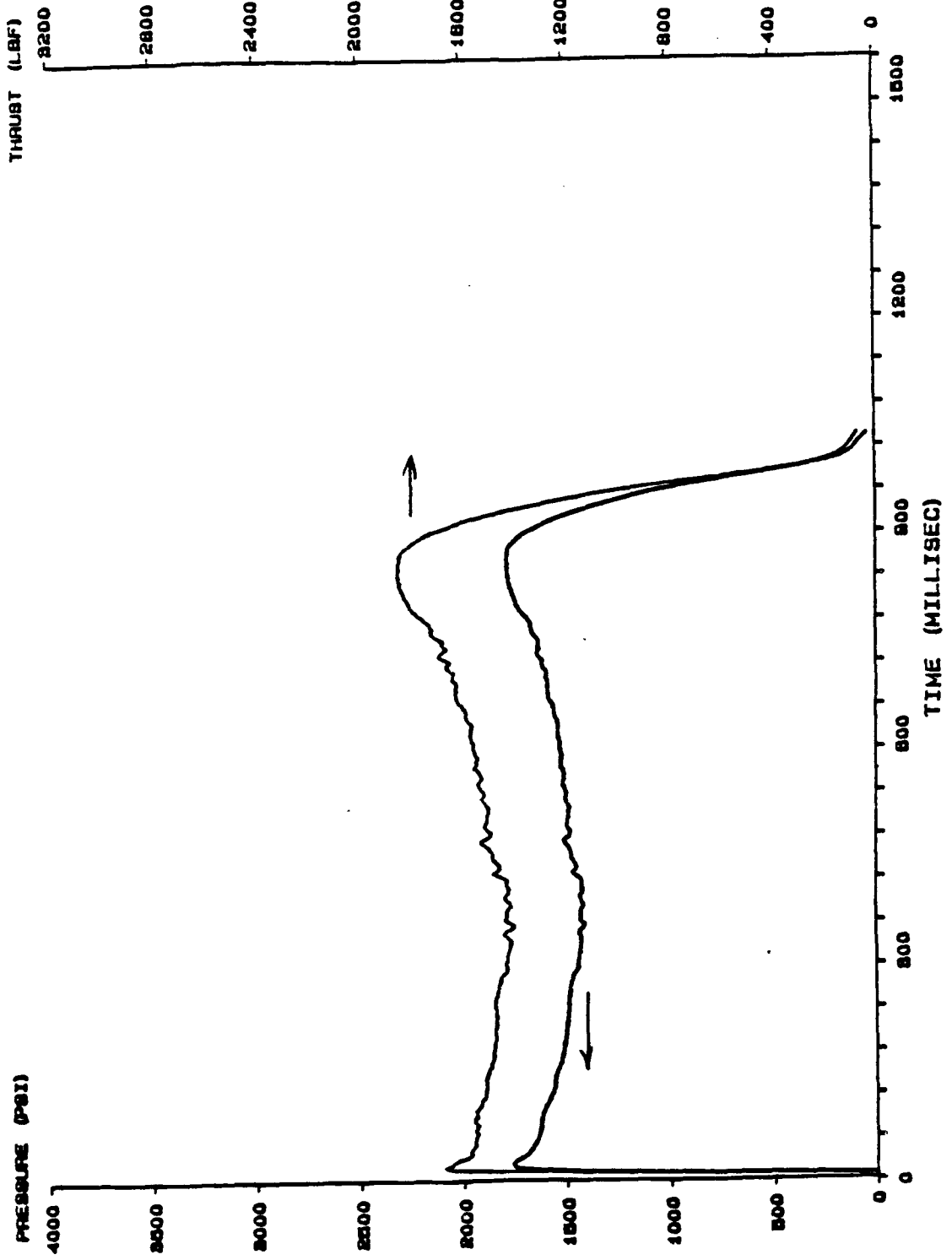

Testing

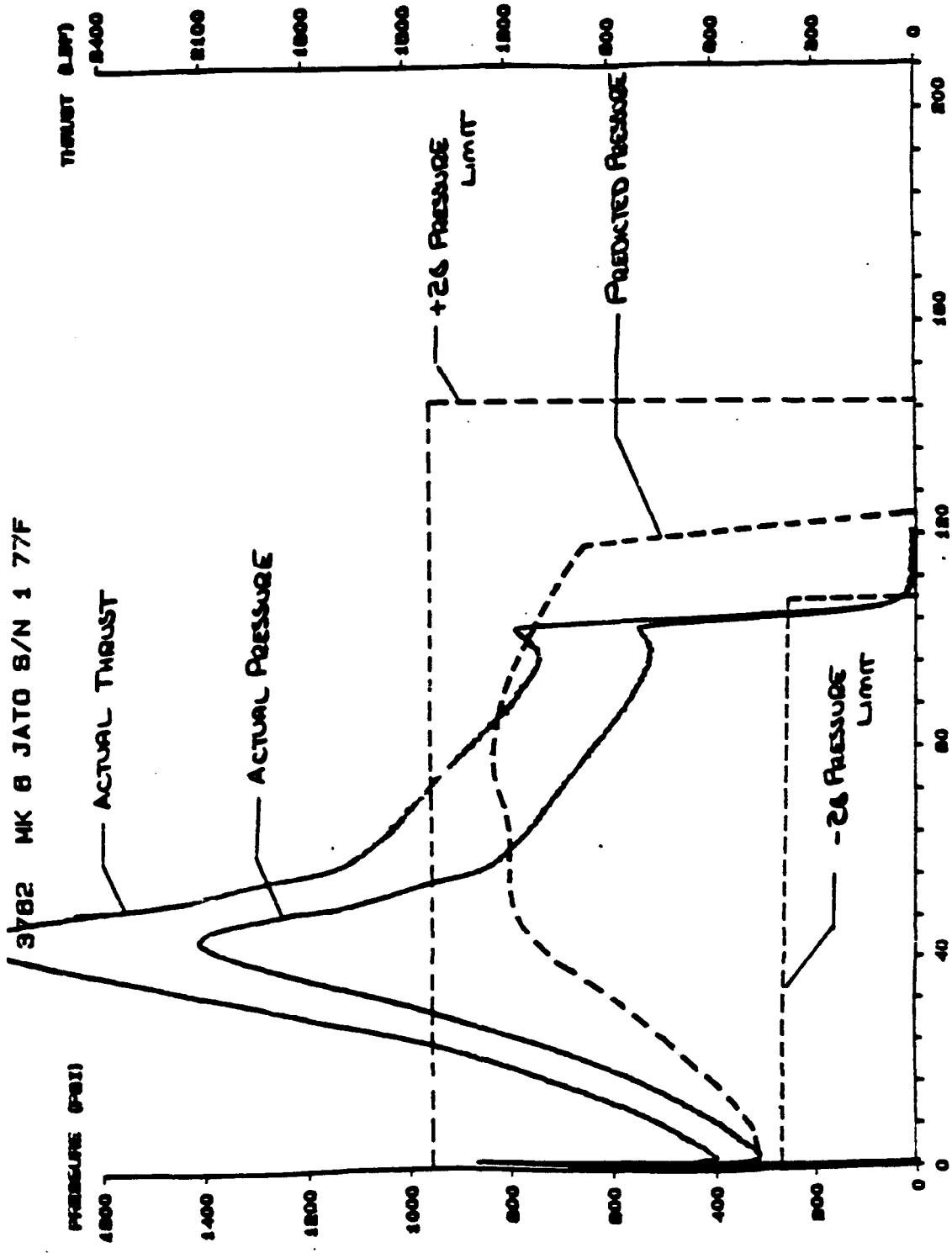

Testing

En. Thoughts

Rocketry has come a long way from Chinese "fire arrows" with ranges of 100 yards to space boosters capable of launching probes beyond the solar system. Yet the principles have remained the same! Only our understanding and application of the principles has developed.

Those of us in the propulsion community take much of this material for granted now – making it as much of a second nature as driving a car. We are so wrapped up with the engineering problems that we don't take time to look back and see how far technology really has come.

Rocket motor development, from inception to production, takes several years. The whole, complex process ties together analysis, test, production, and inspection and involves the close coordination of many people. The chart below will give you an indication of the basic steps. When money to cover the work comes in, design and development work begins. This step includes the analysis, design, and fabrication of prototype units. The designs undergo Ballistic Verification Testing (BVT) and Design Verification Testing (DVT) to assure that all components function as desired and that overall system performance requirements will be met. The qualification test phase (Qual) is an exhaustive test series which subjects sample motors to all of the handling and storage environments to be encountered in the unit's service life.

If the design successfully passes Qual, the unit enters production. Periodic Lot Acceptance Testing (LAT) is conducted to assure that units produced at that particular time also meet the performance requirements.

MOM-107 TARGET BOOSTER PROGRAM FLOW

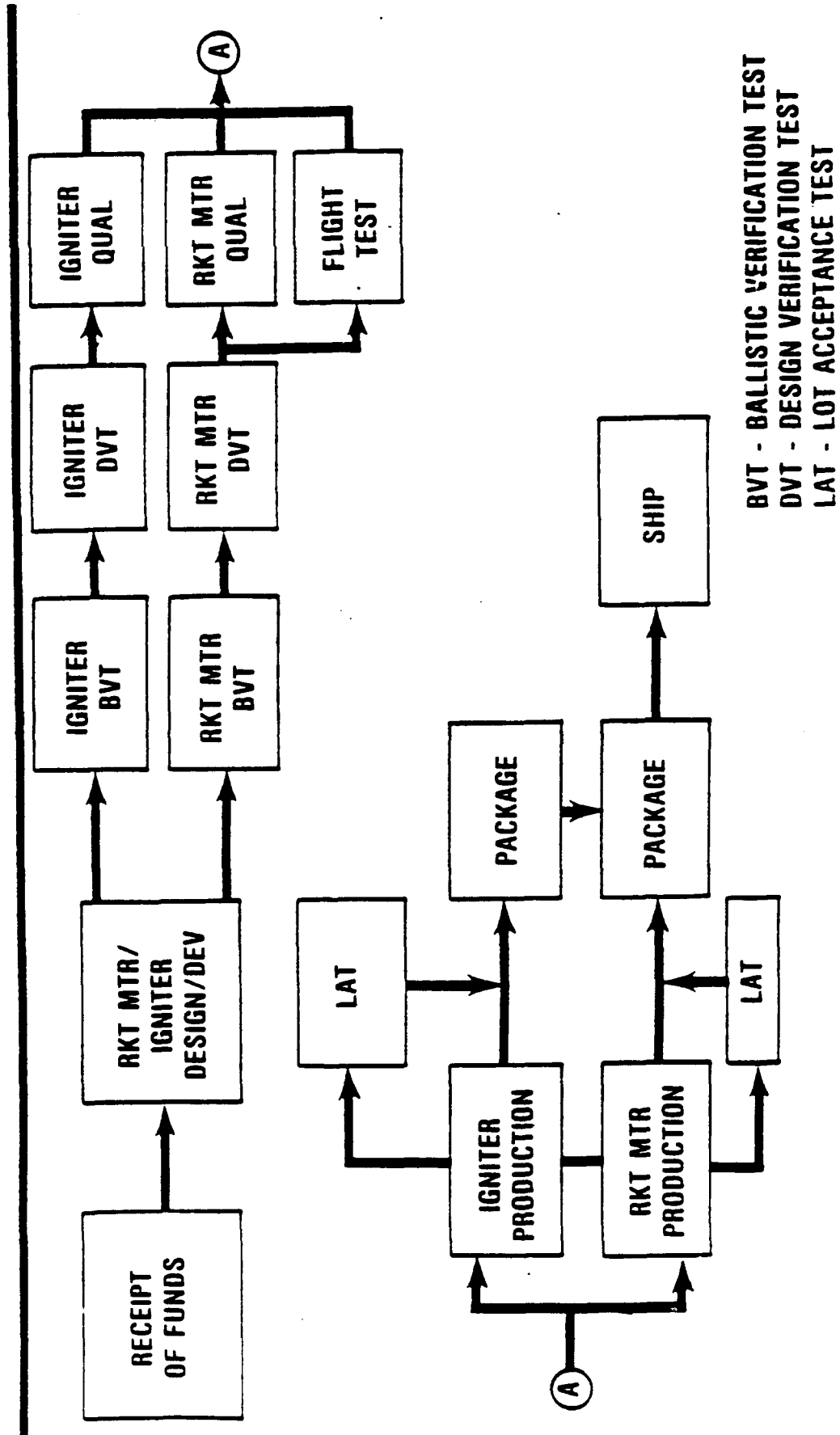

BIBLIOGRAPHY

1. Advanced Ordnance technology notes; series presented by various NAVORDSTA engineers; 1966.
2. Compressed Gas Handbook; J. S. Kunkle et al NASA SP-3045; 1969.
3. History of Rocketry and Space Travel; W. Von Braun; 1966.
4. Introduction to Ordnance Technology; IHSP 76-129; 1976.
5. Physics; D. Halliday and R. Resnick; 1963.
6. Physics Tells Why; O. Luhr; 1946.
7. The Rockets; D. Baker; 1978.
8. Rocket Propulsion Elements; G. P. Sutton; 1964.
9. Rocket Propulsion and Spaceflight Dynamics; J. W. Cornelisse et al; 1979.

APPENDIX A

PROPERTIES OF THE STANDARD ATMOSPHERE

h (ft)	T (°F)	a (ft/sec)	P (#/ft ²)	ρ (slugs/ft ³)
0	59.00	1116	2116.2	.002378
1,000	57.44	1113	2040.9	.002310
2,000	51.37	1109	1967.7	.002242
3,000	48.31	1105	1896.7	.002177
4,000	44.74	1102	1827.7	.002112
5,000	41.18	1098	1760.8	.002049
6,000	37.62	1094	1696.0	.001988
7,000	34.05	1090	1633.0	.001928
8,000	30.49	1086	1571.9	.001869
9,000	26.92	1082	1512.8	.001812
10,000	23.36	1078	1455.4	.001756
11,000	19.80	1074	1399.8	.001702
12,000	16.23	1070	1345.9	.001649
13,000	12.67	1066	1293.7	.001597
14,000	9.10	1062	1243.2	.001546
15,000	5.54	1058	1194.3	.001497
16,000	1.98	1054	1147.0	.001448
17,000	-1.59	1050	1101.1	.001401
18,000	-5.15	1046	1056.9	.001355
19,000	-8.72	1041	1014.0	.001311
20,000	-12.28	1037	972.6	.001267
21,000	-15.84	1033	932.5	.001225
22,000	-19.41	1029	893.8	.001183
23,000	-22.97	1025	856.4	.001143
24,000	-26.54	1021	820.3	.001104
25,000	-30.10	1017	785.3	.001066
26,000	-33.66	1012	751.7	.001029
27,000	-37.23	1008	719.2	.000993
28,000	-40.79	1004	687.9	.000957
29,000	-44.36	999	657.6	.000923
30,000	-47.92	995	628.5	.000890
31,000	-51.48	991	600.4	.000858
32,000	-55.05	987	573.3	.000826
33,000	-58.61	982	547.3	.000796
34,000	-62.18	978	522.2	.000766
35,000	-65.74	973	498.0	.000737
40,000	-67.6	971	391.8	.000586
45,000	-67.6	971	308.0	.000460
50,000	-67.6	971	242.2	.000362
60,000	-67.6	971	150.9	.000224
70,000	-67.6	971	93.5	.000139
80,000	-67.6	971	58.0	.000086
90,000	-67.6	971	36.0	.000054
100,000	-67.6	971	22.4	.000033
150,000	113.5	1174	3.0	.000003
200,000	159.4	1220	.7	.000001

Density of Miscellaneous Non-Metallic Solids

Name	Density*		Name	Density*	
	g per cu cm	lb per cu ft		g per cu cm	lb per cu ft
Agate	2.5-2.7	156-168	Lava, basaltic	2.8-3.0	175-187
Amber	1.06-1.11	66-69	trachytic	2.0-2.7	125-168
Asbestos	2.0-2.8	125-175	Leather	.68-1.02	54-64
Asphalt	1.1-1.5	69-94	Lime, mortar	1.65-1.78	103-111
Basalt	2.4-3.1	150-193	quick (in bulk)	0.8-0.96	50-60
Bauxite	2.55	159	slaked	1.3-1.4	81-87
Beeswax	0.96-0.97	60-61	Limestone	2.00-2.9	125-181
Biotite	2.7-3.1	168-193	Litharge		
Borax	1.7-1.8	106-112	(artificial)	9.3-9.4	580-587
Brick, soft	1.6	100	natural	7.8-8.0	487-499
common	1.79	112	Magnesia		
hard	2.0	125	carbonate	2.4	150
pressed	2.16	135	Magnetite	4.9-5.2	306-324
fire	2.24-2.4	140-150	Marble	2.6-2.84	162-177
sand lime	2.18	136	Masonry, dry		
Brickwork			rubble	2.24-2.56	140-160
mortar	1.6	100	dressed	2.24-2.88	140-180
cement	1.79	112	Mica	2.6-3.2	162-200
Carbon, diamond	3.52	220	Muscovite	2.76-3.00	172-187
graphite	2.25	140	Oligoclase	2.56-2.67	165-167
Cement, natural	2.8-3.2	175-200	Orthoclase	2.58-2.61	161-163
Portland	3.05-3.15	190-197	Paper	0.7-1.15	44-72
loose	1.44	90	Pitch	1.07	67
barreled	1.84	115	Plaster-of-Paris	1.5-1.8	94-112
slag	1.9-2.3	119-144	Porcelain	2.3-2.5	143-156
Chalk	1.9-2.8	119-175	Porphyry	2.6-2.9	162-181
Charcoal, oak	0.57	35	Pumice	0.37-0.90	23-56
pine	0.28-0.44	17-27	Pyrite	4.95-5.1	309-318
Clay	1.8-2.6	112-160	Quartz	2.65	165
Coal, anthracite	1.4-1.8	87-112	Quartzite	2.73	170
bituminous	1.2-1.6	75-100	Resin	1.07	67
charcoal	0.27-0.58	17-36	Riprap		
lignite	1.1-1.4	69-87	limestone	1.3-1.4	81-87
Coke	1.0-1.7	62-106	sandstone	1.4	87
Concrete		144	shale	1.7	106
Corundum	3.9-4.0	244-250	Rock salt	2.18	136
Dolomite	2.84	177	Rubber		
Earth			caoutchouc	0.92-0.96	57-60
dry, loose	1.2	75	manufactured	1.0-2.0	62-125
packed	1.5	94	Salt	0.78-1.25	49-78
moist, loose	1.3	81	Sand, dry	1.44-1.76	90-110
packed	1.6	100	wet	1.89-2.07	118-129
mud, flowing	1.7	106	Selenium	4.82	301
packed	1.8	112	Serpentine	2.50-2.65	156-165
Emery	4.0	250	Shale	2.6-2.9	162-181
Feldspar	2.55-2.75	159-172	Silicon	2.42	151
Flint	2.63	164	Slag, bank	1.1-1.2	69-75
Garnet	3.15-4.3	197-268	bank screenings	1.5-1.9	94-119
Gas carbon	1.88	117	furnace	2.0-3.9	125-244
Gelatin	1.27	80	machine	1.5	94
Glass, common	2.5-2.75	156-172	sand	0.8-0.9	50-56
crystal	2.90-3.00	181-187	Slate	2.6-3.3	162-205
flint	3.2-4.7	200-294	Soapstone	2.6-2.8	162-175
plate	2.45-2.72	153-170	Starch	1.53	95
Glue	1.75	80	Stone, various	2.16-3.4	135-212
Gneiss	2.4-2.7	150-169	crushed	1.6	100
Granite	2.65-2.7	165-169	Sugar	1.61	100
Gravel, dry, loose	1.4-1.7	87-106	Sulfur	2.0-2.1	125-131
packed	1.6-1.9	100-119	Tale	2.7-2.8	168-175
wet	1.9	119	Tar, bituminous	1.02	66
Gypsum	2.31-2.33	144-145	Terracotta	1.9	119
Hematite	4.9-5.3	306-330	Tile	1.76-1.92	110-120
Hornblende	3.0	187	Tourmaline	3.0-3.2	187-200
Iodine	4.94	308	Traprock	2.72-3.4	170-212
Ivory	1.33-1.92	114-120	Wood		

*Ordinary temperatures understood.

Density Characteristics of Common Liquids under Atmospheric Pressure at 60 F

Liquid	Density		Liquid	Density	
	slug/ft ³	lb/ft ³		slug/ft ³	lb/ft ³
Alcohol, ethyl	1.53	49.3	Mercury	26.3	847
Benzene	1.71	54.9	Oil		
Brine (20% NaCl)	2.23	71.6	lubricating	1.65-1.70	53-55
Carbon tetrachloride	3.09	99.5	crude	1.65-1.80	53-58
Gasoline	1.28-1.34	41-43	Water	1.80-1.90	58-61
Glycerin	2.45	78.8	fresh	1.94	62.4
Kerosene	1.51-1.59	49-51	salt	1.99	64.0

Density Characteristics of Common Gases under Atmospheric Pressure at 60 F

Gas	Density	
	slug/ft ³	lb/ft ³
Acetylene	0.00215	0.0693
Air	.00237	.0763
Ammonia	.00141	.0455
Carbon dioxide	.00363	.117
Helium	.000329	.0106
Hydrogen	.000165	.00531
Methane (natural gas)	.00132	.0424
Nitrogen	.00229	.0739
Oxygen	.00262	.0844
Sulfur dioxide	.00537	.173

SUMMARY OF EROSION RATE EQUATIONS

<u>Material and Application</u>	<u>Erosion Rate (in/sec)</u>		
	<u>Exponent</u>	<u>Coefficient</u>	<u>Rate at P_c = 1000</u>
<u>Tungsten</u>			
Higher	1.8	2.0 x 10 ⁻⁹	0.0005
Lower	1.8	6.4 x 10 ⁻¹⁰	0.00016
<u>Pyrolytic Graphite</u>			
Edge Grain	1.8	3.4 x 10 ⁻⁹	0.00085
Coatings, Higher Rates	1.8	1.84 x 10 ⁻⁸	0.0046
Coatings, Lower Rates	1.8	4.4 x 10 ⁻¹⁰	0.00011
<u>Polycrystalline Graphite</u>			
G-90 in TX486 (SAM-D, AD)	1.426	2.78 x 10 ⁻⁶	0.0053
G-90 in TX417 and TE364	1.5	1.56 x 10 ⁻⁷	0.0049
ATJ in TX354	0.907	9.824 x 10 ⁻⁶	0.0052
ATJ in TX174	1.937	6.605 x 10 ⁻⁹	0.0043
CS in TX143	2.444	2.092 x 10 ⁻¹⁰	0.0045
<u>Carbon-Carbon</u>			
Carbitex 700 in 2.75	1.04	1.398 x 10 ⁻⁵	0.0184
Pyrocarb 901	1.262	1.277 x 10 ⁻⁶	0.0078
<u>Graphite Phenolic</u>			
Tape & Laminated (14 motors)	1.262	2.346 x 10 ⁻⁶	0.0143
Poseidon (6 FS + 5 SS)	0.739	8.380 x 10 ⁻⁵	0.0138
<u>Carbon-Phenolic</u>			
Tape & Laminated (6 motors)	1.80	6.09 x 10 ⁻⁸	0.0153
<u>Silica-Phenolic</u>			
Tape - Wrap in TX486-1	0.791	1.154 x 10 ⁻⁴	0.027
Std. Tape in TX454	0.934	4.56 x 10 ⁻⁵	0.029
H.W. Tape in TX454	1.685	1.72 x 10 ⁻⁷	0.019
<u>Glass-Phenolic</u>			
FM16771 in TX622	0.824	1.53 x 10 ⁻⁴	0.045
FM16771 in TX546-3	0.7416	2.22 x 10 ⁻⁸	0.037
FM16771 in TX546-5	0.8304	1.39 x 10 ⁻⁸	0.043
FM16771 in TX546	0.824	1.11 x 10 ⁻⁸	0.033
FM16771 in LCLM	0.8046	1.55 x 10 ⁻⁸	0.040

STAR Propellant Grain Simulation

```
5 CLS
10 DIM TA(200),LPPP(200),APP(200),TP(200),LPP(200),ASS(200)
20 SCREEN 2
30 PI=3.1415927#
40 DEF FNACS(X)=PI/2-ATN(X/SQR(1-X^2))
50 RF=11:TW=3.3:NO=5:LS1=6.1:R2=.5:ALPHA=26.5:R5=1:NITW=4:LG=1:NE=0
60 GOSUB 1290
70 IF (ALPHA<0) THEN PRINT"bad data... ALPHA less than 0": GOTO 60
80 IF (ALPHA>=90) THEN PRINT"bad data... ALPHA greater than 90": GOTO 60
90 IF(RF-TW-LS1<0) THEN PRINT"bad data... RF too small for star": GOTO 60
100 AR=ALPHA*PI/180
110 C=0
120 KOUNT=0
130 DELTAU=TW/NITW
140 VOL = 0
150 TMX=0
160 LPMX=0
170 KJ=1
180 FOR LK=1 TO 200
190 LPPP(LK)=0
200 NEXT LK
210 X45=(R2+R5)*COS(AR)
220 Y45=RF-TW-LS1+R2*(1-SIN(AR))-R5*SIN(AR)
230 LC=((RF-TW-R5)^2-(X45*COS(AR)-Y45*SIN(AR))^2)
240 LC=SQR(LC)-X45*SIN(AR)-Y45*COS(AR)
250 IF (LC<0) THEN PRINT"bad data... LC less than 0": GOTO 60
260 X07=X45+LC*SIN(AR)
270 Y07=Y45+LC*COS(AR)
280 X=Y07/SQR(X07^2+Y07^2)
290 THETA2=FNACS(X)
300 IF(THETA2>PI/NO) THEN PRINT"bad data... no 'flat' at star fillet":GOTO 60
310 T6MAX=R2+LC*TAN(AR)
320 T7MAX=SQR(X07^2+(RF-Y07)^2)-R5
330 IF(LG<T7MAX*NE) THEN PRINT"bad data... grain too short for this many ends" :
340 B71MAX=FNACS(SQR((T7MAX+R5)^2-(RF-Y07)^2)/(T7MAX+R5))-AR
350 IF (B71MAX<0) THEN PRINT"bad data... B71 max less than 0": GOTO 60
360 B72MAX=PI/2+THETA2-B71MAX-AR
370 GOSUB 1740
380 INPUT"HIT ANY KEY TO CONTINUE";SS
390 CLS
400 TAU=0
410 IF(TAU<R2) THEN GOTO 440
420 L1=0
430 GOTO 460
440 L1=(R2-TAU)*(3.14159/2-AR)
450 AF1=(R2-TAU)*L1
460 IF(TAU>R2) THEN GOTO 500
470 L6=LC
480 AF6=(R2-2*TAU+T6MAX)*L6
490 GOTO 540
500 IF (TAU>T6MAX) THEN GOTO 530
510 L6=LC*(T6MAX-TAU)/(T6MAX-R2)
520 GOTO 540
530 L6=0
540 IF(TAU>T6MAX) THEN GOTO 580
550 B71=B71MAX
560 AFP=(R5+T7MAX)*(R5+T6MAX)*SIN(B71)-B71*(R5+TAU)^2
570 GOTO 600
580 Z=FNACS(X07/(R5+TAU))
590 B71=B71MAX+AR-Z
```

```

600 IF(TAU>TW) THEN GOTO 660
610 B72=B72MAX
620 AF7=RF^2*THETA2-B72*(R5+TAU)^2-RF*X07+AFP
630 L8=(RF-TW+TAU)*(3.14159/NO-THETA2)
640 AF8=(RF^2-(RF-TW+TAU)^2)*(3.14159/NO-THETA2)
650 GOTO 710
660 TEMP=((R5+TAU)^2+(RF-TW-R5)^2-RF^2)/(2*(R5+TAU)*(RF-TW-R5))
670 Z=FNACS(TEMP)
680 B72=Z-B71MAX-AR+THETA2-3.14159/2
690 L8=0
700 AF8=0
710 L7=(B71+B72)*(R5+TAU)
720 LP=2*NO*(L1+L6+L7+L8)
730 IF (LP<.00001) THEN LP=0
740 IF(TAU>0) THEN GOTO 880
750 AF=NO*(AF1+AF6+AF7+AF8)
760 AP=3.14159*RF^2-AF
770 PRINT" Tau As Ap":PRINT
780 AREAS=LP*(LG-TAU*NE)+NE*(PI*RF^2-AP)
790 IF (AREAS<0) THEN AREAS=0
800 PRINT USING"###.### *****.## *****.##";TAU;AREAS;AP
810 IF(TAU>TMX) THEN TMX=TAU
820 IF(AREAS>LPMX) THEN LPMX=AREAS
830 TA(KJ)=TAU
840 ASS(KJ)=AREAS
850 APP(KJ)=AP
860 KJ=KJ+1
870 GOTO 1010
880 AP=APLAST+((LP+LPLAST)/2)*DELTAU
890 IF(LP<.001) THEN LP=0: AP=PI*RF^2
900 IF(AP>3.14159*RF^2) THEN AP=3.14159*RF^2
910 VOL=VOL+(LP+LPLAST)/2*DELTAU
920 AREAS=LP*(LG-TAU*NE)+NE*(PI*RF^2-AP)
930 IF(AREAS<0) THEN AREAS=0
940 PRINT USING"###.### *****.## *****.##";TAU;AREAS;AP
950 IF(TAU>TMX) THEN TMX=TAU
960 IF(AREAS>LPMX) THEN LPMX=AREAS
970 TA(KJ)=TAU
980 ASS(KJ)=AREAS
990 APP(KJ)=AP
1000 KJ=KJ+1
1010 LPLAST=LP
1020 APLAST=AP
1030 TAU=TAU+DELTAU
1040 IF (TAU>=TW) THEN GOSUB 1690
1050 IF (TAU>T7MAX) THEN GOTO 1070
1060 GOTO 410
1070 IF (C=1) THEN GOTO 1110
1080 C=1
1090 TAU=T7MAX
1100 GOTO 410
1110 PRINT:PRINT"Integrated fuel volume = ";VOL*LG
1120 PRINT:PRINT:INPUT"Want to see surface history ? (y/n) ";CS
1130 IF(CS="n") THEN GOTO 1150 ELSE GOTO 1140
1140 IF(CS="N") THEN GOTO 1150 ELSE GOSUB 2500
1150 PRINT:INPUT"Want to store this surface history (Y/N)";DS
1160 IF(DS="Y") THEN GOTO 1190
1170 IF(DS="y") THEN GOTO 1190
1180 GOTO 1260
1190 INPUT"FILENAME TO STORE THIS DATA";GS

```

```

1200 BS="A "+GS
1210 OPEN "O",#1,BS
1220 FOR L=1 TO KJ-1
1230 PRINT #1,TA(L),ASS(L),APP(L)
1240 NEXT L
1250 CLOSE #1
1260 PRINT:PRINT:INPUT"Another run ? (y/n) ";CS
1270 IF(CS="n") THEN END ELSE GOTO 1280
1280 IF(CS="N") THEN END ELSE GOTO 60
1290 REM *** default input routine ***
1300 PRINT"READY FOR INPUT..... HIT ANY KEY TO CONTINUE":INPUT FS
1310 CLS
1320 PRINT"INPUT THE FUEL RADIUS. DEFAULT = ";RF: INPUT VS
1330 IF(VS="") THEN GOTO 1340 ELSE RF=VAL(VS)
1340 PRINT"INPUT THE WEB THICKNESS. DEFAULT = ";TW: INPUT VS
1350 IF (VS="") THEN GOTO 1360 ELSE TW=VAL(VS)
1360 PRINT"INPUT THE NUMBER OF STAR POINTS, DEFAULT = ";NO :INPUT VS
1370 IF(VS="") THEN GOTO 1380 ELSE NO=VAL(VS)
1380 PRINT"INPUT THE STAR POINT HEIGHT, DEFAULT = ";LS1 : INPUT VS
1390 IF(VS="") THEN GOTO 1400 ELSE LS1=VAL(VS)
1400 PRINT"INPUT THE TIP RADIUS, DEFAULT = ";R2 : INPUT VS
1410 IF (VS="") THEN GOTO 1420 ELSE R2=VAL(VS)
1420 PRINT"INPUT ANGLE ALPHA (IN DEGREES), DEFAULT = ";ALPHA : INPUT VS
1430 IF (VS="") THEN GOTO 1440 ELSE ALPHA=VAL(VS)
1440 PRINT"INPUT THE FILLET RADIUS, DEFAULT = ";R5 : INPUT VS
1450 IF(VS="") THEN GOTO 1460 ELSE R5=VAL(VS)
1460 PRINT"INPUT THE NUMBER OF BURN INCREMENTS, DEFAULT = ";NITW : INPUT VS
1470 IF(VS="") THEN GOTO 1480 ELSE NITW=VAL(VS)
1480 PRINT"INPUT LENGTH OF GRAIN, DEFAULT = ";LG:INPUT VS
1490 IF(VS="") THEN GOTO 1500 ELSE LG=VAL(VS)
1500 PRINT"INPUT THE NUMBER OF GRAIN ENDS TO BURN, DEFAULT = ";NE:INPUT VS
1510 IF(VS="") THEN GOTO 1520 ELSE NE=VAL(VS)
1520 PRINT:PRINT
1530 PRINT:CLS
1540 PRINT"INPUT LISTING:"
1550 PRINT
1560 PRINT"fuel radius = ";RF
1570 PRINT"web thickness = ";TW
1580 PRINT"number of star points = ";NO
1590 PRINT"star point height = ";LS1
1600 PRINT"tip radius = ";R2
1610 PRINT"fillet radius = ";R5
1620 PRINT"alpha = ";ALPHA
1630 PRINT"number of burn increments = ";NITW
1640 PRINT"length of grain = ";LG
1650 PRINT"number of ends burning = ";NE
1660 PRINT
1670 INPUT"ARE THESE INPUTS SATISFACTORY";SS
1671 IF(SS="N") THEN GOTO 1310
1672 IF(SS="n") THEN GOTO 1310
1680 RETURN
1690 IF(KOUNT=0) THEN TAU=TW :DELTAU =TW/NITW
1700 IF (KOUNT=1) THEN TAU=TW+.001:DELTAU=.001
1710 IF(KOUNT>=2) THEN DELTAU=TW/NITW/5
1720 KOUNT=KOUNT+1
1730 RETURN
1740 DEF FNXNEW(X,Y,ANGLE)=X*COS(ANGLE)-Y*SIN(ANGLE)
1750 CLS
1760 DEF FNYNEW(X,Y,ANGLE)=X*SIN(ANGLE)+Y*COS(ANGLE)
1770 SF=150/RF

```

```

1780 XC=300
1790 YC=90
1800 TH=PI/NO
1810 CIRCLE (XC, YC), RF*SF
1820 LINE(XC, YC)-(XC, YC)
1830 FOR ANGLE=0 TO 2*PI STEP 2*PI/NO
1840 XC2=FNXNEW( (RF-TW-LS1+R2), 0, ANGLE)
1850 YC2=FNYNEW( (RF-TW-LS1+R2), 0, ANGLE)/2.38
1860 A1=PI/2+AR+ANGLE
1870 IF(A1>2*PI) THEN A1=A1-2*PI
1880 A2=3*PI/2-AR+ANGLE
1890 IF(A1>2*PI) THEN A2=A2-2*PI
1900 IF(A2>2*PI) THEN A2=A2-2*PI
1910 CIRCLE(XC+XC2*SF, YC-YC2*SF), R2*SF, , A1, A2
1920 X12=(RF-TW-LS1+R2)-R2*SIN(AR)
1930 Y12=R2*COS(AR)
1940 X122=FNXNEW(X12, Y12, ANGLE)*SF
1950 Y122=FNYNEW(X12, Y12, ANGLE)*SF/2.38
1960 LC5=LC
1970 X13=X12+LC5*COS(AR)
1980 Y13=Y12+LC5*SIN(AR)
1990 X133=FNXNEW(X13, Y13, ANGLE)
2000 Y133=FNYNEW(X13, Y13, ANGLE)
2010 LINE(XC+X122, YC-Y122)-(XC+X133*SF, YC-Y133*SF/2.38)
2020 XC5=X13-R5*SIN(AR)
2030 YC5=Y13+R5*COS(AR)
2040 XC52=FNXNEW(XC5, YC5, ANGLE)
2050 YC52=FNYNEW(XC5, YC5, ANGLE)
2060 LINE(XC+XC52*SF, YC-YC52*SF/2.38)-(XC+XC52*SF, YC-YC52*SF/2.38)
2070 A1=3*PI/2+AR+ANGLE
2080 IF(A1>2*PI) THEN A1=A1-2*PI
2090 IF(A1>2*PI) THEN A1=A1-2*PI
2100 A2=THETA2+ANGLE
2110 IF(A2>2*PI) THEN A2=A2-2*PI
2120 IF(A2>2*PI) THEN A2=A2-2*PI
2130 CIRCLE(XC+XC52*SF, YC-YC52*SF/2.38), R5*SF, , A1, A2
2140 A1=THETA2+ANGLE
2150 IF(A1>2*PI) THEN A1=A1-2*PI
2160 IF(A1>2*PI) THEN A1=A1-2*PI
2170 A2=TH+ANGLE
2180 IF(A2>2*PI) THEN A2=A2-2*PI
2190 IF(A2>2*PI) THEN A2=A2-2*PI
2200 CIRCLE(XC, YC), (RF-TW)*SF, , A1, A2
2210 Y12=-R2*COS(AR)
2220 X122=FNXNEW(X12, Y12, ANGLE)*SF
2230 Y122=FNYNEW(X12, Y12, ANGLE)*SF/2.38
2240 Y13=Y12-LC5*SIN(AR)
2250 X133=FNXNEW(X13, Y13, ANGLE)
2260 Y133=FNYNEW(X13, Y13, ANGLE)
2270 LINE(XC+X122, YC-Y122)-(XC+X133*SF, YC-Y133*SF/2.38)
2280 XC5=X13-R5*SIN(AR)
2290 YC5=Y13-R5*COS(AR)
2300 XC52=FNXNEW(XC5, YC5, ANGLE)
2310 YC52=FNYNEW(XC5, YC5, ANGLE)
2320 LINE(XC+XC52*SF, YC-YC52*SF/2.38)-(XC+XC52*SF, YC-YC52*SF/2.38)
2330 A1=2*PI-THETA2+ANGLE
2340 IF(A1>2*PI) THEN A1=A1-2*PI
2350 IF(A1>2*PI) THEN A1=A1-2*PI
2360 A2=PI/2-AR+ANGLE
2370 IF(A2>2*PI) THEN A2=A2-2*PI

```

```

2380 IF(A2>2*PI)THEN A2=A2-2*PI
2390 CIRCLE(XC+XC52*SF,YC-YC52*SF/2.38),R5*SF,,A1,A2
2400 A1=2*PI-TH+ANGLE
2410 IF(A1>2*PI) THEN A1=A1-2*PI
2420 IF(A1>2*PI) THEN A1=A1-2*PI
2430 A2=2*PI-THETA2+ANGLE
2440 IF(A2>2*PI) THEN A2=A2-2*PI
2450 IF(A2>2*PI) THEN A2=A2-2*PI
2460 CIRCLE(XC,YC),(RF-TW)*SF,,A1,A2
2470 NEXT ANGLE
2480 PAINT(XC+RF*SF-1,YC),1
2490 RETURN
2500 CLS
2510 X0=150
2520 Y0=150
2530 TP(1)=TA(1)/TMX*350+150
2540 LPP(1)=150-ASS(1)/LPMX*100
2550 LINE(X0,Y0)-(X0+400,Y0)
2560 LINE(X0,Y0)-(X0,Y0-120)
2570 FOR I=2 TO KJ-1
2580 TP(I)=TA(I)/TMX*350+150
2590 LPP(I)=150-ASS(I)/LPMX*100
2600 LINE(TP(I-1),LPP(I-1))-(TP(I),LPP(I))
2610 NEXT I
2620 RETURN

```

Sample output

VARIABLE LISTING

FUEL RADIUS= 11
 WEB THICKNESS= 3.3
 NUMBER OF POINTS= 5
 STAR POINT HEIGHT= 6.1
 VALLEY RADIUS= .5
 ALPHA= 26.5
 TIP RADIUS= 1
 NUMBER OF BURN INCREMENTS= 4

T= 0	LP= 76.3494	AP= 79.665
T= .825	LP= 78.6165	AP= 143.588
T= 1.65	LP= 76.3965	AP= 207.531
T= 2.475	LP= 74.1766	AP= 269.643
T= 3.3	LP= 73.0852	AP= 330.388
T= 4.125	LP= 27.4297	AP= 371.851
T= 4.95	LP= 8.15081	AP= 386.528
T= 5.32216	LP= 0	AP= 389.89

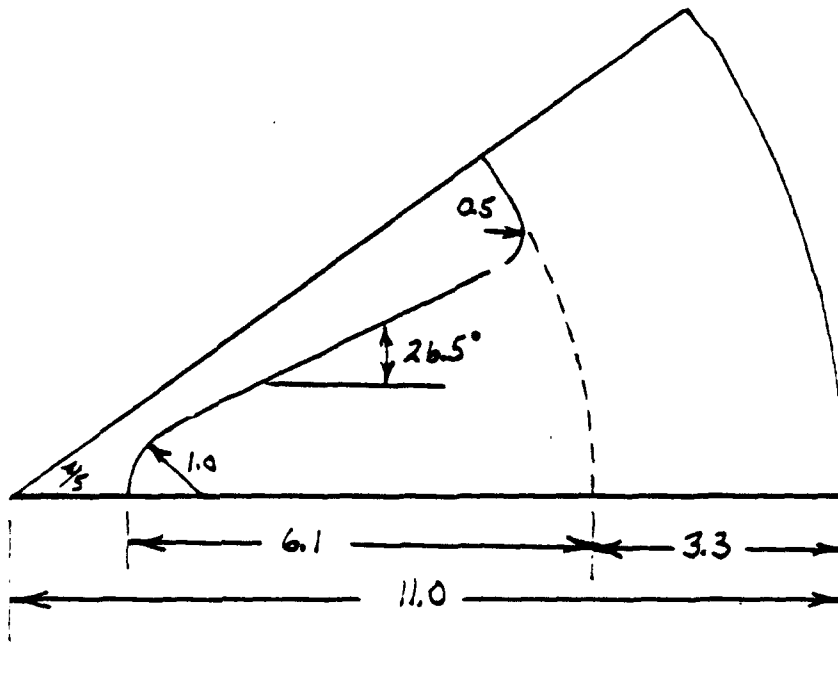

FOPD Program

```
10 REM PROGRAM FOPD
15 DIM TAW(50),SURF(50),PORT(50)
16 DIM TM(200),THRST(200),PRESS(200)
17 DIM PRES(25),RATE(25)
18 DEF FNAS(X)=ATN(X/SQR(1-X^2))
19 DEF FNAC(X)=-ATN(X/SQR(1-X^2))+PI/2
20 PI=3.14159
30 RAD=PI/180
40 G=32.174
50 XCASE=0
60 EPSON = 7
70 IT=40000!
80 F=18000
90 PC=1600
100 KF=1
110 CSTAR=4800
120 GAM=1.19
130 PIK=.0018
140 SIK=.00175
150 DELF=.06
160 LAT=.0429
170 N=.45
180 DELIM=5!
190 ALPHA=15
200 K00=.00001
210 K01=.907
220 CM=.95
230 PA=14.7
240 NO=5!
250 RF=5!
260 NNPD=0
270 ALFAS=5
280 TAUS=.25
290 RS=.25
300 BETA=2/3
310 THI=160
320 TLO=-50
330 TN=70
340 DELTIM=.1
350 TEMPS=0
360 TYPE1=0
365 NITW=42
400 GOSUB 6000
460 XCASE=XCASE+1
470 T3=0
480 CLS:PRINT" CONFIGURATION ";XCASE
500 DELT=DELTIM
510 COEF=LAT
520 CSTOR=CSTAR
530 PSTOR=F
540 AE=PI/4*DELIM^2
550 ALPHAR=ALPHA*RAD
560 LAMN=.5+.5*COS(ALPHAR)
570 EPSONL=EPSON
580 GOSUB 4500
590 GOSUB 4860
600 EPSON=AE/AT
610 IF(ABS(EPSON-EPSONL)/EPSON>.001) THEN GOTO 570
620 IF(PEPC>(PA/PC)) THEN GOTO 670
630 PEPC=PA/PC
```

```

640 GOSUB 4770
650 GOSUB 4860
660 AE=AT*EPSON
670 ISPT=CSTAR*CFLM/G
680 WFT=IT/ISPT
690 TW=IT/F
700 K1=EXP(PIK*(THI-TN))
710 K2=EXP(PIK*(TLO-TN))
720 K3=EXP(SIK*(THI-TN))
730 K4=EXP(SIK*(TLO-TN))
740 TWHI=TW/K3
750 TWLO=TW/K4
760 PHI=PC*K1
770 PLO=PC*K2
780 FHI=(F+PA*AE)*K1-PA*AE
790 FLO=(F+PA*AE)*K2-PA*AE
800 CFLMHI=FHI/PHI/AT
810 CFMLO=FLO/PLO/AT
820 ITHI=FHI*TWHI
830 ITLO=FLO*TWLO
840 ISPTHI=ITHI/WFT
850 ISPTLO=ITLO/WFT
860 VFT=WFT/DELF
870 RB=LAT*PC^N
880 R1000=LAT*1000^N
890 WEB=RB*TW
900 ASBAR=VFT/WEB
910 DTI=SQR(4*AT/PI)-K00*PC^K01*TW
920 ATI=PI*DTI^2/4
930 DTF=SQR(4*AT/PI)+K00*PC^K01*TW
940 ATP=PI*DTF^2/4
950 DE=SQR(4*AE/PI)
960 EPI=(DE/DTI)^2
970 EPF=(DE/DTF)^2
980 PRINT" PARAMETER          TEMPERATURE"
990 PRINT USING"          ###.      ###.      ###. ";TLO;TN;THI
1020 PRINT USING"WEB TIME, SECS  ##.####  ##.####  ##.####";TWLO;TW;TWHI
1040 PRINT USING"THRUST, LBS     #####.###  #####.###  #####.###";FLO;F;FHI
1060 PRINT USING"PRESSURE, PSI  #####.###  #####.###  #####.###";PLO;PC;PHI
1080 PRINT USING"THRUST COEFF. #.####  #.####  #.####";CFMLO;CFLM;CFLMHI
1100 PRINT USING"TOTAL IMPULSE #####.#  #####.#  #####.#";ITLO;IT;ITHI
1120 PRINT USING"ISP           ###.##  ###.##  ###.##";ISPTLO;ISPT;ISPTHI
1125 PRINT:PRINT
1130 PRINT USING"CSTAR   ####.#  DELF   .#####  GAMMA  #.####";CSTAR;DELF;GAM
1140 PRINT USING"RATE COEFF. .#####  N      .####  RB      ##.###";LAT;N;RB
1150 PRINT USING"DTI     ##.####  K00   .#####  K01   .####";DTI;K00;K01
1160 PRINT USING"DE      ##.####  ALPHA  ##.###  EPSON  ##.####";DE;ALPHA;EPSON
1170 PRINT USING"WFT     #####.##  VFT   #####.##  TAUW   ##.####";WFT;VFT;WEB
1180 PRINT USING"PA      ##.##  R1000  ##.###  ASBAR  #####.###";PA;R1000;ASBAR
1190 PRINT USING"CM      .####  PIK   .#####  SIK   .#####";CM;PIK;SIK
1200 PRINT:PRINT:PRINT
1201 INPUT"ANOTHER RUN (Y/N)";G$
1202 IF(G$="N") THEN END ELSE GOTO 1203
1203 IF(G$="n") THEN END ELSE GOTO 400
4500 REM  PEPC SUBROUTINE
4510 GAMP1=GAM+1
4520 GAMM1=GAM-1
4530 RETAN=0
4540 PEPC1=1
4550 TEMP1=(PEPC1^(1/GAM))

```



```

4560 TEMP2=(SQR(GAMM1/(GAMP1-(2*PEPC1)/TEMP1)))/EPSON
4570 TEMP=TEMP2/TEMP1-1
4580 IF(ABS(TEMP)-.00001>=0) THEN GOTO 4590 ELSE GOTO 4740
4590 PEPC2=TEMP2^GAM
4600 IF(RETAN<>0) THEN GOTO 4660 ELSE GOTO 4610
4610 RETAN=1
4620 PPC1=1
4630 PPC2=PEPC2
4640 PEPC1=PEPC2
4650 GOTO 4550
4660 TEMP3=PPC2-PEPC2
4670 TEMP4=PPC1-PEPC1
4680 PPC2=PEPC2
4690 PPC1=PEPC1
4700 PEPC1=(PEPC1*TEMP3-PEPC2*TEMP4)/(TEMP3-TEMP4)
4710 IF(PEPC1-1>=0) THEN GOTO 4720 ELSE GOTO 4550
4720 PEPC1=PEPC2
4730 GOTO 4550
4740 PEPC=PEPC1*(2/GAMP1)^(GAM/GAMM1)
4750 RETURN
4770 REM      EP SUBROUTINE
4780 GP1=GAM+1
4790 GM1=GAM-1
4800 TOP=(2/GP1)^(1/GM1)*(1/PEPC)^(1/GAM)
4810 BOT=1-(PEPC)^(GM1/GAM)
4820 BOT=(BOT*GP1/GM1)^.5
4830 EPSON=TOP/BOT
4840 RETURN
4860 REM      CFL1 SUBROUTINE
4880 GP1=GAM+1
4890 GM1=GAM-1
4900 A=(1-PEPC^(GM1/GAM))*2*GAM*GAM/GM1
4910 B=A*(2/GP1)^(GP1/GM1)
4920 CFV=SQR(B)+PEPC*EPSON
4930 CFLM=CM*(CFV*LAMN+PEPC*EPSON*(1-LAMN))
4940 CFLM=CFLM-PA/PC*EPSON
4944 IF(PON=0) THEN PON=PC
4945 IF(Q>1) THEN CFLM=CFLM+PA/PC*EPSON-PA/PON*EPSON:RETURN
4950 AT=F/PC/CFLM
4960 RETURN
6000 REM      DEFAULT INPUT SUBROUTINE
6010 CLS
6020 PRINT"INPUT DESIRED TOTAL IMPULSE.  DEFAULT =";IT:INPUT V$
6030 IF(V$="") THEN GOTO 6040 ELSE IT=VAL(V$)
6040 PRINT"INPUT DESIRED THRUST.  DEFAULT =";F:INPUT V$
6050 IF(V$="") THEN GOTO 6060 ELSE F=VAL(V$)
6060 PRINT"INPUT DESIRED PRESSURE.  DEFAULT =";PC:INPUT V$
6070 IF(V$="") THEN GOTO 6080 ELSE PC=VAL(V$)
6080 PRINT"INPUT CSTAR.  DEFAULT =";CSTAR:INPUT V$
6090 IF(V$="") THEN GOTO 6100 ELSE CSTAR=VAL(V$)
6100 PRINT"INPUT PROPELLANT DENSITY.  DEFAULT =";DELF:INPUT V$
6110 IF(V$="") THEN GOTO 6120 ELSE DELF=VAL(V$)
6120 PRINT"INPUT GAMMA.  DEFAULT =";GAM:INPUT V$
6130 IF(V$="") THEN GOTO 6140 ELSE GAM=VAL(V$)
6140 PRINT"INPUT BURN RATE COEFFICIENT.  DEFAULT =";LAT:INPUT V$
6150 IF(V$="") THEN GOTO 6160 ELSE LAT=VAL(V$)
6160 PRINT"INPUT BURN RATE EXPONENT.  DEFAULT =";N:INPUT V$
6170 IF(V$="") THEN GOTO 6180 ELSE N=VAL(V$)
6180 PRINT"INPUT PI-K.  DEFAULT =";PIK:INPUT V$
6190 IF(V$="") THEN GOTO 6200 ELSE PIK=VAL(V$)

```

```
6200 PRINT"INPUT SIGMA-K.  DEFAULT =";S1K:INPUT V$
6210 IF(V$="") THEN GOTO 6220 ELSE S1K=VAL(V$)
6220 PRINT"INPUT MOTOR EFFICIENCY.  DEFAULT =";CM:INPUT V$
6230 IF(V$="") THEN GOTO 6240 ELSE CM=VAL(V$)
6240 PRINT"INPUT THROAT EROSION COEFFICIENT.  DEFAULT =";K00:INPUT V$
6250 IF(V$="") THEN GOTO 6260 ELSE K00=VAL(V$)
6260 PRINT"INPUT THROAT EROSION EXPONENT.  DEFAULT =";K01:INPUT V$
6270 IF(V$="") THEN GOTO 6280 ELSE K01=VAL(V$)
6280 PRINT"INPUT NOZZLE HALF ANGLE.  DEFAULT =";ALPHA:INPUT V$
6290 IF(V$="") THEN GOTO 6300 ELSE ALPHA =VAL(V$)
6300 PRINT"INPUT NOZZLE EXIT DIAMETER.  DEFAULT =";DELIM:INPUT V$
6310 IF(V$="") THEN GOTO 6320 ELSE DELIM=VAL(V$)
6320 PRINT"INPUT LOW OPERATING TEMPERATURE.  DEFAULT =";TLO:INPUT V$
6330 IF(V$="") THEN GOTO 6340 ELSE TLO=VAL(V$)
6340 PRINT"INPUT NOMINAL OPERATING TEMPERATURE.  DEFAULT =";TN:INPUT V$
6350 IF(V$="") THEN GOTO 6360 ELSE TN=VAL(V$)
6360 PRINT"INPUT HIGH OPERATING TEMPERATURE.  DEFAULT =";THI:INPUT V$
6370 IF(V$="") THEN GOTO 6380 ELSE THI=VAL(V$)
6380 RETURN
```

Sample input & output

VARIABLE LIST

#	VARIABLE	VALUE
1	TOTAL IMPULSE	400000
2	THRUST	25000
3	CHAMBER PRESSURE	2000
4	CHAR EXHAUST VELOCITY	5050
5	PROPELLANT DENSITY	.06
6	GAMMA	1.19
7	PI-K	.0022
8	SIGMA-K	.00215
9	BURN RATE COEFFICIENT	.00549
10	BURN RATE EXPONENT	.69
11	NOZZLE EXIT DIAMETER	7.5
12	NOZZLE HALF ANGLE	15
13	NOZZLE EROSION COEFF	0
14	NOZZLE EROSION EXPONENT	0
15	MOTOR COEFFICIENT	.96
16	ATMOSPHERIC PRESSURE	14.7
17	HOT TEMPERATURE	130
18	NOMINAL TEMPERATURE	70
19	LOW TEMPERATURE	-45

OUTPUT NOMENCLATURE

DELF - PROPELLANT DENSITY
 RB - BURNING RATE AT MOTOR PRESSURE
 DTI - NOZZLE PREFIRE THROAT DIAMETER
 K00 - NOZZLE EROSION COEFFICIENT
 K01 - NOZZLE EROSION EXPONENT
 DE - NOZZLE EXIT DIAMETER
 ALPHA - EXIT CONE HALF-ANGLE
 EPSON - NOZZLE EXPANSION RATIO
 WFT - TOTAL PROPELLANT WEIGHT
 VFT - TOTAL PROPELLANT VOLUME
 TAUW - REQUIRED GRAIN WEB THICKNESS
 PA - ATMOSPHERIC PRESSURE
 R1000 - BURN RATE AT 1000 PSI
 ASBAR - REQUIRED AVERAGE BURNING SURFACE
 - MOTOR EFFICIENCY

CONFIGURATION 1

PARAMETER	TEMPERATURE		
	-45	70	130
WEB TIME SEC	20.4880	16.0000	14.3636
THRUST LBS	19266.50	25000.00	28619.30
PRESSURE PSI	1552.940	2000.000	2282.220
THRUST COEFF.	1.54467	1.55631	1.56131
TOTAL IMPULSE	394732	400000	402491
ISP LB-SEC/LB	241.060	244.276	245.797
CSTAR	5050.0000	EPSILON	5.50044
DELF	0.06000	WFT	1637.49000
GAMMA	1.19000	VFT	27291.50000
LAT	0.00549	TAUW	16.64960
N	0.69000	PA	14.70000
RB	1.04060	R1000	0.64502
DTI	3.19788	ASBAR	1639.17000
K00	0.00000	CM	0.96000
K01	0.00000	PI-K	0.00220
DE	7.50000	SIGMA-K	0.00215
ALPHA	15.00000		

APPENDIX B
INTRODUCTION TO ROCKET PROPULSION
PROBLEMS

INTRODUCTION TO ROCKET PROPULSION PROBLEMS

1. On a standard day the barometer will read 29.92 inches of Hg. What is this pressure in psi? If a pressure gauge reads 10 psi, what is the absolute pressure acting on the gauge?
2. a) Find the pressure in lb/in^2 , 500 feet below the surface of the ocean.
b) Find the pressure in the atmosphere ten miles above sea level.
3. Water is poured to the same level in each of the three vessels shown, all of the same base area. If the pressure is the same at the bottom of each vessel, the force experienced by the base of each vessel is the same. Why then do the three vessels have different weights when put on a scale? This apparently contradictory result is commonly known as the "hydrostatic paradox."

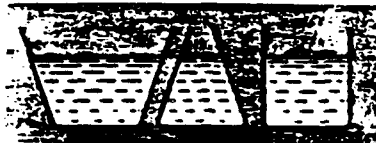

4. Explain why an inflated balloon will rise to a definite height once it starts to rise, whereas a submarine will always sink to the bottom of the ocean once it starts to sink, if no changes are made. How then can a submarine stay at a definite level under the water?
5. A simple U-tube contains mercury. When 13.6 inches of water is poured into the right arm, how high does the mercury rise in the left arm from its initial level?
6. If the effective temperature of the atmosphere at 80,000 feet is -67.6°F convert this to:
a. $^\circ\text{C}$ b. $^\circ\text{K}$ c. $^\circ\text{R}$
7. Oxygen boils at -183°C . What is its boiling point in
a. $^\circ\text{F}$ b. $^\circ\text{R}$ c. $^\circ\text{K}$
8. At what temperature do the Fahrenheit and Celsius scales give the same reading? The Fahrenheit and the Kelvin scales?
9. The density of standard sea level air is .002378 slugs per cubic foot.
a. What is its weight density?
b. What is its specific volume?
10. A room (10 x 20 x 30) ft^3 contains standard sea level air.
a. What is the weight of the air in the room?
b. What is the mass of the air in the room?
c. What is the specific volume of the air?

11. If a combustion chamber heats air from 300°F to 1500°F at a constant pressure of 75 psia, what are the changes in specific volume and weight density? Air has a molecular weight of 29.
12. An airplane tire has a volume of one cubic foot. If the pressure in the tire is 50 psig and the temperature is 70°F , what weight of air is in the tire when it is at sea level?
13. A spherical balloon 30 feet in diameter is filled at sea level conditions with hot air at 240°F and 2 psig.
- What is the weight of the air in the balloon?
 - What is the weight of the air it displaces?
 - What is the lifting force if the balloon itself weighs 100#?
 - If the balloon were filled with hydrogen at the same conditions, what would the lifting force be? (M.W. of hydrogen is 2)
14. One pound of a gas (molecular weight = 30) is compressed in a cylinder to a volume of one cubic foot and a pressure of 300 psig. If the atmospheric pressure is 14.7 psia, what is the final gas temperature?
15. Air is heated at constant pressure until its temperature is doubled. What is the change in:
- specific volume
 - weight density
 - mass density
 - weight
16. A rigid container contains air at the standard conditions of 26,000 feet. Heat is applied to the container so that the temperature is raised 100°F .
- What is the initial density?
 - What is the final pressure?
 - What is the final density?
17. How will the temperature of a given mass of air change if its volume is decreased five times and its pressure is increased ten times?
18. An aircraft flies at an altitude of 25,000 feet with a speed of 500 mph. What is its flight Mach #?
19. The final velocity of the final stage of a multistage rocket is much greater than the final velocity of a single-stage rocket of the same total weight and fuel supply. Explain this fact.
20. Why is the following statement false: "A rocket cannot move under its own power in outer space because there is no air for its exhaust to push against"?
21. A bird is in a wire cage hanging from a spring balance. Is the reading of the balance when the bird is flying greater than, less than, or the same as that when the bird sits in the cage?
22. A body is acted on by two forces F_1 and F_2 , as shown below. If $w = 5\text{lbw}$, $F_1 = 3\text{ lbf}$, and $F_2 = 4\text{ lbf}$, find the vector acceleration of the body.

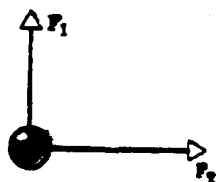

23. A block of mass m is supported by a cord C from the ceiling, and another cord D is attached to the bottom of the block. Explain the following observations: If you give a sudden jerk to D it will break, but if you pull on D steadily C will break.

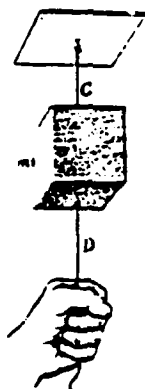

24. A bucket of water is suspended from a spring balance. Does the balance reading change when a piece of iron suspended from a string is immersed in the water? When a piece of cork is put in the water?

25. Three blocks are connected, as shown below on a horizontal frictionless table and pulled to the right with a force $T_3 = 60$ lbsf. If $m_1 = 10$ lbm, $m_2 = 20$ lbm, and $m_3 = 30$ lbm, find the tensions T_1 and T_2 .

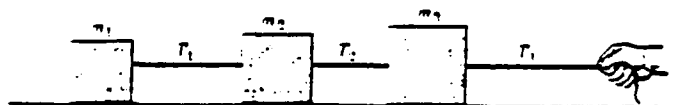

26. A block of mass $m_1 = 1$ slugs on a smooth inclined plane of angle 30° is connected by a cord over a small frictionless pulley to a second block of mass $m_2 = 2$ slugs hanging vertically.
- What is the acceleration of each body?
 - What is the tension in the cord?

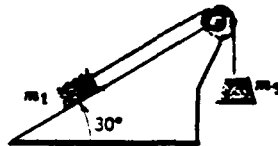

27. A uniform flexible chain one foot long, weighing λ lb/ft, passes over a small frictionless, massless pulley. It is released from a rest position with x feet of chain hanging from one side and $(1-x)$ feet from the other side.
- Under what circumstances will it accelerate?
 - Assuming these circumstances are met, find the acceleration a as a function of x .
28. A car moving initially at a speed of 50 miles/hr and weighing 3000 lb is brought to a stop in a distance of 200 feet. Find the braking force and the time required to stop. Assuming the same braking force, find the distance and time required to stop if the car was going 25 miles/hr initially.
29. A 13,200 lb rocket is set for a vertical firing. If the exhaust speed is 3280 ft/sec, how much gas must be ejected per second to supply the thrust needed
- to overcome the weight of the rocket,
 - to give the rocket an initial upward acceleration of 64 ft/sec^2 ?
30. a) Water flows in a 4" diameter pipe at a velocity of 20 ft/sec. What is the mass flow rate and the weight flow rate?
 b) If the water came to a sudden enlargement in the pipe, the diameter of the enlargement being 8", what would the velocity of the water be in the enlarged section ($\rho g = 62.4 \text{ #/ft}^3$)
31. Air at standard sea level conditions enters a nozzle of inlet area 40 in^2 at a velocity of 20 ft/sec. It leaves the nozzle at a pressure of 7 psia, a temperature of 38°F , and exit area of 3.21 in^2 . What is the exit velocity and mass and weight flow rates?
32. A garden hose having an internal diameter of 0.75 inches is connected to a lawn sprinkler that consists merely of an enclosure with 24 holes, each 0.05 in. in diameter. If the water in the hose has a speed of 3.0 ft/sec, at what speed does it leave the sprinkler holes?
33. A vessel at rest explodes, breaking into three pieces. Two pieces, having equal mass, fly off perpendicular to one another with the same speed of 300 ft/sec. The third piece has three times the mass of each other piece. What is the direction and magnitude of its velocity immediately after the explosion?
34. (a) Can a body have energy without having momentum? Explain.
 (b) Can a body have momentum without having energy? Explain.

35. What is the momentum of a 4000-lb car whose speed is 30 mph? At what speed would a 10-ton truck have the same momentum? The same kinetic energy?

36. A 200-lb man standing on a surface of negligible friction kicks forward a 0.1 lb stone lying at his feet so that it acquires a speed of ten ft/sec. What velocity does the man acquire as a result?

37. A Venturi meter has a pipe diameter of 10.0 in. and a throat diameter of 5.0 inches. If the water pressure in the pipe is 8.0 lb/in^2 and in the throat is 6.0 lb/in^2 , determine the rate of flow of water in ft^3/sec (volume flux).

38. Models of torpedoes are sometimes tested in a pipe of flowing water, much as a wind tunnel is used to test model airplanes. Consider a circular pipe of internal diameter 10.0 inches and a torpedo model, aligned along the axis of the pipe, with a diameter of 2.0 inches. The torpedo is to be tested with water flowing past it at 8.0 ft/sec.

- (a) With what speed must the water flow in the unstricted part of the pipe?
- (b) What will the pressure difference be between the constricted and unstricted parts of the pipe?

39. Air streams horizontally past an airplane wing of area 36 ft^2 weighing 540 lb. The speed over the top surface is 200 ft/sec and 150 ft/sec under the bottom surface. What is the lift on the wing? The net force on it?

40. A hollow tube has a disk **DD** attached to its end. When air is blown through the tube, the disk attracts the card **CC**. Let the area of the card be A and let V be the average airspeed between **CC** and **DD**; calculate the resultant upward force on **CC**. Neglect the card's weight. See figure below.

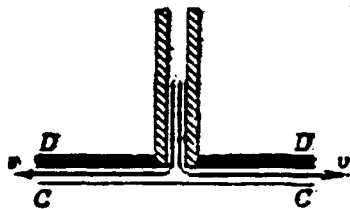

41. A tank is filled with water to a height H . A hole is punched in one of the walls at a depth H below the water surface.

- (a) Find the distance x from the foot of the wall at which the stream strikes the floor.
- (b) Could a hole be punched at another depth so that this second stream would have the same range? If so, at what depth? See figure above.

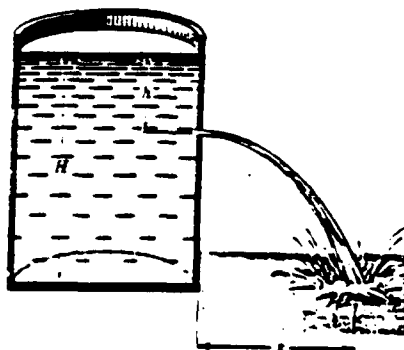

42. One pound of a gas (MW = 30) is heated from 500 R to 1500°R at constant pressure by the absorption of 250 BTU. Calculate R, Cp, Cv, γ change in U, and change in h.

43. A horse is urged to pull a wagon. The horse refuses to try, citing Newton's third law for this situation as his defense: "The pull of the horse on the wagon is equal but opposite to the pull of the wagon on the horse. If I can never exert a greater force on the wagon than it exerts on me, how can I ever start the wagon moving?" asks the horse. How would you reply?

44. Air (compressible, with $\gamma = 1.4$) flows through a nozzle under the following condition:

$$\begin{aligned} P_1 &= 20 \text{ psi} \\ P_2 &= 14.7 \text{ psia} \\ T_1 &= 1600^\circ\text{F} \\ T_2 &= 1405^\circ\text{F} \\ V_1 &= 0 \end{aligned}$$

What is the exit velocity?

45. Design an optimum nozzle for an ideal rocket which has to operate at 40,000 feet altitude and give a 1000-lb thrust at a chamber pressure of 300 psia and a chamber temperature of 5000°R. Assume that $\gamma = 1.30$ and $R = 66$. Determine the throat area, exit area, throat velocity, exit velocity, and exit temperature.

46. Given the following data for a rocket:

Time	Thrust
0	1500
.5	2000
1.0	1750
2.0	1800
2.5	1800
3.0	1700
3.25	1800
3.30	0

Determine the total impulse of the motor.

47. During strand test of two composite solid propellants, the following data were obtained. The initial propellant temperature was the same in each case.

Propellant 1	Pressure (psia)	Burning Rate (inch/sec)
	900	0.117
	1220	0.133
	1402	0.139
	1601	0.150
	1810	0.159

Propellant 2	Pressure (psia)	Burning Rate (inch/sec)
	898	0.742
	1181	0.920
	1400	1.053
	1605	1.181
	1802	1.296

Determine appropriate empirical relationships between burning rate and pressure for these propellants.

48. A rocket motor has been designed with a nozzle expansion ratio of 8.5. What is the ratio of exit pressure to chamber pressure for the motor? Ratio of specific heats for the combustion gas is 1.19.

49. During static test of a ballistic test motor the following were measured, recorded directly, or computed:

Time integral of combustion chamber pressure over the equilibrium burning time of the propellant = 619 psia-secs

Throat area of the nozzle = 0.962 in²

Nozzle expansion ratio = 8.5

Atmospheric pressure = 14.69 lbs/in²

Weight of propellant burned = 5.5 lbs

Percent of propellant burned during equilibrium time (estimated from trace) = 95%

Equilibrium burning time = 0.621 sec

Ratio of specific heats of combustion gases = 1.20

Average molecular weights of exhaust = 29.9 lbs/lb mole

- Determine:
- The characteristic velocity
 - The average specific impulse delivered
 - The average thrust delivered
 - The flame temperature of the propellant

50. Determine the ratio of the burning area to the nozzle throat area for a solid propellant rocket motor with the following characteristics. Neglect effect of erosive burning.

Burning rate data n = 0.4
 a = 0.0076

Chamber pressure 1000 psia

Propellant weight density 0.064 lbs/in³

Specific heat ratio of combustion products 1.19

Gas constant 70 ft/°R

Propellant flame temperature 5500°R

51. A solid propellant rocket motor has the following characteristics:

Nozzle throat area 1 inch²

Initial port area 1.5 inch²

Nozzle expansion ratio 7.0

Ratio of specific heats of exhaust products 1.215

Design maximum operating pressure 1000 psia

Determine the initial equilibrium sea level thrust of the rocket motor when designed to operate at maximum chamber pressure by:

Assuming no total pressure drop in the combustion chamber.

52. Given the following additional information about the motor in the previous problem

$$r_b = .00546 P_c^{0.69} \text{ in/sec}$$

$$T_c = 5745^\circ\text{R}$$

$$\rho = .0585 \text{ lb/in}^3$$

$$\text{Gas molecular wt} = 26.4$$

- a. Assuming no mass addition, find the length of an internal burning, cylindrical grain with $A_p = 1.5 \text{ in}^2$ which has an initial equilibrium pressure of 1000 psi. Neglect burning on the grain ends.
- b. What is the initial motor head end pressure when mass addition is included?

53. Determine the minimum port area at the aft end of the propellant grain of a case-bonded solid propellant rocket motor for which no erosive burning will take place if the following data apply:

$$\text{Threshold velocity} = 200 \text{ ft/sec}$$

$$\text{Flame temperature} = 5000^\circ\text{F}$$

$$\text{Nozzle throat cross-sectional area} = 1 \text{ inch}^2$$

$$\text{Ratio of specific heats of combustion products} = 1.24$$

$$\text{Molecular weight of combustion products} = 22.0 \text{ lb/lbmole}$$

(Assume that the ends of the grain are inhibited so that only the surface of the perforation is burning)

What do you conclude about the existence of erosive burning in practical rocket motors assuming this propellant data is typical?

54. Given the motor in problem 52 and assuming the final equilibrium chamber pressure is 1000 psia and the grain burns out at all points simultaneously, determine the time after burnout required to reach 50 psia when the inside diameter of the motor case is 10 inches. Assume the total empty volume of the motor is ten percent greater than the volume of the cylindrical portion.

55. Show that for a cylindrical perf grain with web fraction = 0.5 burning on both ends, neutrality ($A_{s_i} = A_{s_f}$) is obtained when $L/D = 1.75$.

56. A 6.75 inch diameter rocket motor is to be designed for a MEOP of 2780 psi. Compare the thickness and weight of steel vs. an aluminum case design. The density of steel is 0.283 \#/in^3 and aluminum weighs $.100 \text{ \#/in}^3$. $\sigma_{\text{steel}} = 150 \text{ ksi}$ and $\sigma_{\text{al}} = 65 \text{ ksi}$

57. A small high thrust rocket motor has been designed by an inexperienced designer, (i.e., he didn't take Introduction to Rocket Propulsion) with an initial port-to-throat area ratio of 1.0. A design burst pressure of 1200 psi was used in determining the thickness of the case and this strength was verified by a rigorous test-to-failure program. Unfortunately, the first two motors to be tested burst upon ignition whereupon further testing was suspended. The igniter is known to have worked satisfactorily on a similar motor. SAE 4130 steel was used in the design of the motor case. The ratio of specific heats of the propellant gases is 1.2. There were no unanticipated temperature conditions and the propellant is known to be relatively insensitive to temperature changes.

- a. List five reasonable possible causes of the failure based on the information given above.

- b. While reviewing this design and the failures, you discover that during each test a single transducer placed at the nozzle throat to measure static pressure at that point recorded a maximum pressure of 660 psia just prior to the failures. Prove, if it is possible, based upon this information and that given above, that the failure could have been caused by a single phenomenon.

INITIAL DISTRIBUTION

	<u>Copies</u>
AMSMI-RD	1
AMSMI-RD-CS-R	5
AMSMI-RD-CS-T	1
AMSMI-GC-IP, Mr. Bush	1
AMSMI-RD-PR-S, Mr. Lyon	50
U.S. Army Materiel System Analysis Activity	
ATTN: AMXSU-MP (Herbert Cohen)	1
Aberdeen Proving Ground, MD 21005	
IIT Research Institute	
ATTN: GACIAC	1
10 W. 35th Street	
Chicago, IL 60616	

DIST-1/(DIST-2 Blank)