



# AMD RS880D Databook

**Technical Reference Manual**  
**Rev 1.30**

P/N: 46135\_rs880d\_ds\_pub\_1.30  
© 2010 Advanced Micro Devices Inc

Please note that in this databook, references to "DVI" and "HDMI" may refer to: (1) the function of the integrated DVI/HDMI interface described in details in section 2.3 and 3.8, as well as in other sections; or (2) the capability of the TMDS interface, multiplexed on the PCI-E external graphics interface, to enable DVI or HDMI through passive enabling circuitries. Any statement in this databook on any DVI or HDMI-related functionality must be understood to apply to (1), (2), or both, according to the immediate context of the reference.

USE OF THIS PRODUCT IN ANY MANNER THAT COMPLIES WITH THE MPEG-2 STANDARD IS EXPRESSLY PROHIBITED WITHOUT A LICENSE UNDER APPLICABLE PATENTS IN THE MPEG-2 PATENT PORTFOLIO, WHICH LICENSE IS AVAILABLE FROM MPEG LA, L.L.C., 6312 S. FIDDLERS GREEN CIRCLE, SUITE 400E, GREENWOOD VILLAGE, COLORADO 80111.

#### **Trademarks**

AMD, the AMD Arrow, ATI, the ATI logo, 3Dc+, AMD Athlon, AMD Phenom, AMD OverDrive, AMD PowerNow!, Avivo, Cool'n'Quiet, HyperMemory, PowerPlay, PowerShift, AMD PowerXpress, AMD Radeon, SurroundView, Vari-Bright, CrossFire, and combinations thereof are trademarks of Advanced Micro Devices, Inc.

DisplayPort is a trademark of the Video Electronics Standards Association.

HyperTransport is a trademark of the HyperTransport Technology Consortium.

Microsoft, Windows, Windows Vista, Windows 7, DirectDraw, and DirectX are registered trademarks of Microsoft Corporation.

OpenGL is a registered trademark of Silicon Graphics Internal.

PCI Express and PCIe are registered trademarks of PCI-SIG.

WinBench is a registered trademark of Ziff Davis, Inc.

Linux is a registered trademark of Linus Torvalds in the U.S. and other countries.

Other product names used in this publication are for identification purposes only and may be trademarks of their respective companies.

#### **Disclaimer**

The contents of this document are provided in connection with Advanced Micro Devices, Inc. ("AMD") products. AMD makes no representations or warranties with respect to the accuracy or completeness of the contents of this publication and reserves the right to make changes to specifications and product descriptions at any time without notice. No license, whether express, implied, arising by estoppel, or otherwise, to any intellectual property rights are granted by this publication. Except as set forth in AMD's Standard Terms and Conditions of Sale, AMD assumes no liability whatsoever, and disclaims any express or implied warranty, relating to its products including, but not limited to, the implied warranty of merchantability, fitness for a particular purpose, or infringement of any intellectual property right.

AMD's products are not designed, intended, authorized or warranted for use as components in systems intended for surgical implant into the body, or in other applications intended to support or sustain life, or in any other application in which the failure of AMD's product could create a situation where personal injury, death, or severe property or environmental damage may occur. AMD reserves the right to discontinue or make changes to its products at any time without notice.

# Table of Contents

---

## Chapter 1: Overview

1.1	Introducing the RS880D .....	1-1
1.2	RS880D Features .....	1-2
1.2.1	CPU HyperTransport™ Interface .....	1-2
1.2.2	Memory Interface .....	1-2
1.2.3	AMD HyperMemory™ .....	1-2
1.2.4	PCI Express® Interface .....	1-2
1.2.5	A-Link Express III Interface .....	1-4
1.2.6	2D Acceleration Features .....	1-4
1.2.7	3D Acceleration Features .....	1-4
1.2.8	Motion Video Acceleration Features .....	1-5
1.2.9	Multiple Display Features .....	1-5
1.2.10	DVI/HDMI™ .....	1-7
1.2.11	DisplayPort™ Interface .....	1-7
1.2.12	Integrated HD Audio Controller and Codec .....	1-8
1.2.13	System Clocks .....	1-8
1.2.14	Power Management Features .....	1-8
1.2.15	PC Design Guide Compliance .....	1-8
1.2.16	Test Capability Features .....	1-8
1.2.17	Packaging .....	1-9
1.3	Software Features .....	1-9
1.4	Branding Diagram .....	1-9
1.5	Graphics Device ID and Graphics Engine Clock Speed .....	1-10
1.6	Conventions and Notations .....	1-10
1.6.1	Pin Names .....	1-10
1.6.2	Pin Types .....	1-10
1.6.3	Numeric Representation .....	1-11
1.6.4	Register Field .....	1-11
1.6.5	Hyperlinks .....	1-11
1.6.6	Acronyms and Abbreviations .....	1-11

## Chapter 2: Functional Descriptions

2.1	Host Interface .....	2-1
2.2	Side-Port Memory Interface .....	2-3
2.2.1	DDR2 Memory Interface .....	2-3
2.2.2	DDR3 Memory Interface .....	2-5
2.3	DVI/HDMI™ .....	2-6
2.3.1	DVI/HDMI™ Data Transmission Order and Signal Mapping .....	2-6
2.3.2	Support for HDMI™ Packet Types .....	2-9
2.4	VGA DAC Characteristics .....	2-10
2.5	Clock Generation .....	2-10

## Chapter 3: Pin Descriptions and Strap Options

3.1	Pin Assignment Top View .....	3-2
3.1.1	RS880D Pin Assignment Top View .....	3-2
3.2	Interface Block Diagram .....	3-4
3.3	CPU HyperTransport™ Interface .....	3-5

3.4	Side-port Memory Interface .....	3-5
3.5	PCI Express® Interfaces .....	3-6
3.5.1	1 x 16 Lane Interface for External Graphics .....	3-6
3.5.2	A-Link Express III Interface for Southbridge .....	3-6
3.5.3	6 x 1 Lane Interface for General Purpose External Devices .....	3-6
3.5.4	Miscellaneous PCI Express® Signals .....	3-6
3.6	Clock Interface .....	3-7
3.7	CRT Interface .....	3-7
3.8	Integrated DVI/HDMI™ Interface .....	3-8
3.9	TMD5 Interface Multiplexed on the PCI Express® Graphics Lanes .....	3-9
3.10	DisplayPort™ Interface .....	3-10
3.11	Power Management Pins .....	3-11
3.12	Miscellaneous Pins .....	3-11
3.13	Power Pins .....	3-12
3.14	Ground Pins .....	3-13
3.15	Strapping Options .....	3-14
<b>Chapter 4: Timing Specifications</b>		
4.1	HyperTransport™ Bus Timing .....	4-1
4.2	HyperTransport™ Reference Clock Timing Parameters .....	4-1
4.3	PCI Express® Differential Clock AC Specifications .....	4-2
4.4	Timing Requirements for REFCLK_P Used as OSCIN (14.3181818MHz) .....	4-2
4.5	Side-port Memory Timing for DDR2 Mode .....	4-2
4.5.1	Read Cycle DQ/DQS Delay .....	4-2
4.5.2	Write Cycle DQ/DQS Delay .....	4-3
4.6	Power Rail Power-up Sequence .....	4-3
<b>Chapter 5: Electrical Characteristics and Physical Data</b>		
5.1	Electrical Characteristics .....	5-1
5.1.1	Maximum and Minimum Ratings .....	5-1
5.1.2	DC Characteristics .....	5-2
5.2	RS880D Thermal Characteristics .....	5-6
5.2.1	RS880D Thermal Limits .....	5-6
5.2.2	Thermal Diode Characteristics .....	5-7
5.3	Package Information .....	5-8
5.3.1	Physical Dimensions .....	5-8
5.3.2	Pressure Specification .....	5-9
5.3.3	Board Solder Reflow Process Recommendations .....	5-10
<b>Chapter 6: Power Management and ACPI</b>		
6.1	ACPI Power Management Implementation .....	6-1
6.2	Power Management for the Graphics Controller .....	6-2
6.2.1	PCI Function Power States .....	6-2
6.2.2	PCI Power Management Interface .....	6-2
6.2.3	Capabilities List Data Structure in PCI Configuration Space .....	6-2
6.2.4	Register Block Definition .....	6-3
6.2.5	Capability Identifier: CAP_ID (Offset = 0) .....	6-4
6.2.6	Next Item Pointer (Offset = 1) .....	6-5
6.2.7	PMC - Power Management Capabilities (Offset = 2) .....	6-6

**Chapter 7: Testability**

7.1 Test Capability Features.....	7-1
7.2 Test Interface.....	7-1
7.3 XOR Test.....	7-1
7.3.1 Description of a Generic XOR Tree.....	7-1
7.3.2 Description of the RS880D XOR Tree.....	7-2
7.3.3 XOR Tree Activation.....	7-2
7.3.4 XOR Tree for the RS880D.....	7-2
7.4 VOH/VOL Test.....	7-4
7.4.1 Description of a Generic VOH/VOL Tree.....	7-4
7.4.2 VOH/VOL Tree Activation.....	7-5
7.4.3 VOH/VOL Pin List.....	7-6

**Appendix A: Pin Listings**

A.1 RS880D Pin List Sorted by Ball Reference.....	1-2
A.2 RS880D Pin List Sorted by Pin Name.....	1-7

**Appendix B: Revision History**

This page is left blank intentionally.

# List of Figures

---

Figure 1-1: Possible Configurations for the x16 PCIe® Graphics Interface .....	1-3
Figure 1-2: RS880D Multiple Display Options .....	1-6
Figure 1-3: RS880D ASIC A11 Production Branding .....	1-10
Figure 2-1: RS880D Internal Block Diagram .....	2-1
Figure 2-2: Host Interface Block Diagram .....	2-2
Figure 2-3: RS880D Host Bus Interface Signals .....	2-3
Figure 2-4: RS880D Side-Port Memory Interface .....	2-4
Figure 2-5: Data Transmission Ordering for the Integrated DVI/HDMI™ and TMDS Interfaces .....	2-6
Figure 3-1: RS880D Pin Assignment Top View (Left) .....	3-2
Figure 3-2: RS880D Pin Assignment Top View (Right) .....	3-3
Figure 3-3: RS880D Interface Block Diagram .....	3-4
Figure 5-1: DC Characteristics of the Integrated DVI/HDMI™ and the TMDS Interfaces .....	5-5
Figure 5-2: RS880D 528-Pin FCBGA Package Outline .....	5-8
Figure 5-3: RS880D Ball Arrangement (Bottom View) .....	5-9
Figure 5-4: Recommended Stencil Opening Sizes for Solder Paste Pads on PCB .....	5-10
Figure 5-5: RoHS/Lead-Free Solder (SAC305/405 Tin-Silver-Copper) Reflow Profile .....	5-11
Figure 6-1: Linked List for Capabilities .....	6-5
Figure 7-1: Example of a Generic XOR Tree .....	7-2
Figure 7-2: Sample of a Generic VOH/VOL Tree .....	7-5

This page is left blank intentionally.

# List of Tables

---

Table 1-1: Possible Configurations for the PCIe® General Purpose Links .....	1-3
Table 1-2: Graphics Device ID and Graphics Engine Clock Speed .....	1-10
Table 1-3: Pin Type Codes .....	1-10
Table 1-4: Acronyms and Abbreviations .....	1-11
Table 2-1: Supported DDR2 Components .....	2-4
Table 2-2: DDR2 Memory Row and Column Addressing .....	2-4
Table 2-3: Supported DDR3 Components .....	2-5
Table 2-4: DDR3 Memory Row and Column Addressing .....	2-5
Table 2-5: Single Link Signal Mapping for DVI/HDMI™ .....	2-7
Table 2-6: Dual-Link Signal Mapping for DVI .....	2-8
Table 2-7: Support for HDMI™ Packet Type .....	2-9
Table 2-8: VGA DAC Characteristics .....	2-10
Table 3-1: CPU HyperTransport™ Interface .....	3-5
Table 3-2: Side-Port Memory Interface .....	3-5
Table 3-3: 1 x 16 or 2 x 8 Lane PCI Express® Interface for External Graphics .....	3-6
Table 3-4: 1 x 4 Lane A-Link Express III Interface for Southbridge .....	3-6
Table 3-5: 6 x 1 Lane PCI Express® Interface for General Purpose External Devices .....	3-6
Table 3-6: PCI Express® Interface for Miscellaneous PCI Express® Signals .....	3-6
Table 3-7: Clock Interface .....	3-7
Table 3-8: CRT Interface .....	3-7
Table 3-9: Integrated DVI/HDMI™ Interface .....	3-8
Table 3-10: TMDS Interface Multiplexed on the PCI Express® Graphics Interface (Dual-Link DVI) .....	3-9
Table 3-11: TMDS Interface Multiplexed on the PCI Express® Graphics Interface (HDMI™ on Lane 0-3) .....	3-9
Table 3-12: TMDS Interface Multiplexed on the PCI Express® Graphics Interface (HDMI™ on Lane 4-7) .....	3-9
Table 3-13: Miscellaneous TMDS Interface Signals .....	3-10
Table 3-14: DisplayPort™ Interface Multiplexed on the PCI Express® Graphics Interface .....	3-10
Table 3-15: Miscellaneous DisplayPort™ Signals .....	3-11
Table 3-16: Power Management Pins .....	3-11
Table 3-17: Miscellaneous Pins .....	3-11
Table 3-18: Power Pins .....	3-12
Table 3-19: Ground Pins .....	3-13
Table 3-20: Strap Definitions for the RS880D .....	3-14
Table 4-1: Timing Requirements for HyperTransport™ Reference Clock (100MHz) Output by the Clock Generator .....	4-1
Table 4-2: PCI Express® Differential Clock (GFX_REFCLK, GPPSB_REFCLK, 100MHz) AC Characteristics .....	4-2
Table 4-3: Timing Requirements for REF_CLKP Used as OSCIN (14.3181818MHz) .....	4-2
Table 4-4: RS880D Power Rail Power-up Sequence .....	4-3
Table 5-1: Maximum and Minimum Ratings .....	5-1
Table 5-2: DC Characteristics for 3.3V TTL Signals .....	5-2
Table 5-3: DC Characteristics for DDC Signals (DDC Mode) .....	5-2
Table 5-4: DC Characteristics for AUX Signals (AUX Mode) .....	5-2
Table 5-5: DC Characteristics for POWERGOOD .....	5-2
Table 5-6: DC Characteristics for HyperTransport™ and PCI-E Differential Clock (HT_REFCLK, GFX_REFCLK, GPPSB_REFCLK, 100MHz) .....	5-3
Table 5-7: DC Characteristics for REFCLK_P as OSCIN Input (14.3181818MHz) .....	5-3
Table 5-8: DC Characteristics for the Memory Interface when Supporting DDR2 .....	5-3
Table 5-9: DC Characteristics for the Memory Interface when Supporting DDR3 .....	5-3
Table 5-10: DC Characteristics for the Integrated DVI/HDMI™ .....	5-4
Table 5-11: DC Characteristics for the TMDS Interface Multiplexed on the PCI Express® Gfx Lanes .....	5-4
Table 5-12: Electrical Specifications for the DisplayPort Interface .....	5-5
Table 5-13: RS880D Thermal Limits .....	5-6
Table 5-14: RS880D 528-Pin FCBGA Package Physical Dimensions .....	5-8
Table 5-15: Recommended Board Solder Reflow Profile - RoHS/Lead-Free Solder .....	5-11

Table 6-1: ACPI States Supported by the RS880D .....	6-1
Table 6-2: ACPI Signal Definitions .....	6-1
Table 6-3: Standard PCI Configuration Space Header Type 0 .....	6-2
Table 6-4: PCI Status Register .....	6-3
Table 6-5: Capabilities Pointer (CAP_PTR) .....	6-3
Table 6-6: Power Management Register Block .....	6-3
Table 6-7: Power Management Control/Status Register (PMCSR) .....	6-4
Table 6-8: Capability Identifier (CAP_ID) .....	6-4
Table 6-9: Next Item Pointer (NEXT_ITEM_PTR) .....	6-5
Table 6-10: Power Management Capabilities – PMC .....	6-6
Table 7-1: Pins on the Test Interface .....	7-1
Table 7-2: Example of an XOR Tree .....	7-2
Table 7-3: RS880D XOR Tree .....	7-3
Table 7-4: Truth Table for the VOH/VOL Tree Outputs .....	7-5
Table 7-5: RS880D VOH/VOL Tree .....	7-7

# Chapter 1

## Overview

### 1.1 Introducing the RS880D

The RS880D is an eighth-generation high-end Integrated Graphics Processor (IGP) that integrates a DirectX® 10.1 compliant Shader Model 4.1 graphics core, a Universal Video Decoder (UVD) 2.0, and a system controller in a single chip. It supports AMD's AM3-socket CPUs, including the AMD Phenom™ II and later desktop processors. The RS880D integrates an ATI RV620-based graphics engine, dual digital displays, an integrated DVI/HDMI™ interface, internal or external TMDS, DisplayPort capability, and Northbridge functionality in a single BGA package. The ATI Hybrid Graphics® technology provides significant performance boost to AMD-based systems by enabling both the discrete GPU and the RS880D graphics core to render simultaneously in Hybrid CrossFire® mode. It supports two x8 PCI Express® (PCIe®) links in CrossFire® mode, and is also capable of driving 6 monitors under the SurroundView™ set-up. This high level of integration and scalability enables manufacturers to offer enthusiast level capabilities and performance while minimizing board space and system cost.

#### Robust and Flexible Core Logic Features

The RS880D combines graphics and system logic functions in a single chip using a 21mm body BGA package, reducing overall solution area. For optimal system and graphics performance, the RS880D supports a high speed HyperTransport™ interface to the AMD processor, running at a data rate of up to 4.8 GT/s and supporting both HT 1.0 and HT 3.0 protocols. The RS880D is ideally suited for 64-bit operating systems, and supports platform configurations with greater than 4GB of system memory. The rich PCI Express® (PCIe®) expansion capabilities of RS880D include support for PCI Express external graphics and up to six other PCI Express peripherals, all supporting the PCI Express 2.0 standard with data rates of up to 5.0GT/s. These capabilities are complemented by the advanced I/O features of AMD's SB700 and SB800-series Southbridges.

#### Designed for Windows Vista®

The RS880D delivers a compelling Windows Vista experience. It harnesses the increased bandwidth of HyperTransport 3.0 to a DirectX 10.1 graphics core, which provides the 3D rendering power needed to generate the Windows Vista desktop even under the most demanding circumstances. The AMD RV620-based graphics core employs a unified shader architecture to deliver excellent 3D performance across the whole spectrum of 3D applications. It meets all current Windows Vista Premium Logo requirements.

#### Leading 3D Performance

Coupled with the latest AMD Phenom II processor, improved memory controller architecture, and the HyperTransport 3.0 interface, the RS880D delivers an exceptional 3D performance. With a discrete graphic card, the Hybrid CrossFire set-up provides an exhilarating 3D performance, allowing users to play most 3D games available in the market today. The RS880D also supports two x8 PCI Express Gen 2 links for a CrossFire set-up.

#### Leading Multimedia Capabilities

The RS880D incorporates AMD's Unified Video Decoder (UVD) 2.0 technology, which provides dedicated hardware decode of the H.264, VC-1, and MPEG-2 video formats used for HD contents and Blu-ray disks. The RS880D also incorporates the innovative AMD Avivo™ HD display architecture, providing users with amazing visual quality. Advanced scaling and color correction capabilities, along with increased precision through the entire display pipeline, ensure an exceptional image on CRT monitors, LCD panels, and any other display device. Dual DisplayPort output capability provides the ability to interface to the next generation of digital display devices. That is complemented by a fully integrated DVI/HDMI and HDCP support, allowing compatibility with even the most modern high definition televisions without the additional cost of external components.

**\*Note:** AMD Avivo HD is a technology platform that includes a broad set of capabilities offered by certain AMD Radeon™ products. Support for any AMD Avivo HD capability is subject to qualification of the RS880D ASIC. Full enablement of some AMD Avivo HD capabilities may require complementary products.

## Low Power Consumption and Industry Leading Power Management

The RS880D is manufactured using the power efficient 55 nm technology, and it supports a whole range of industry standards and new proprietary power management features. System power can be further reduced through the dedicated local frame buffer interface supported by the RS880D. The integrated UVD dramatically reduces CPU loading and hence overall power consumption during Blu-ray video and HD contents playback.

## Software Compatibility

The graphics driver for the RS880D is fully compatible with all other AMD Radeon™ class graphics controllers from AMD. A single driver can support multiple graphics configurations across AMD's product lines, including the AMD Radeon family and the AMD chipset family. In addition, this driver compatibility allows the RS880D to benefit immediately from AMD's software optimization and from the advanced Windows® XP, Windows Vista®, and Windows 7® support available in the Radeon family drivers.

## 1.2 RS880D Features

### 1.2.1 CPU HyperTransport™ Interface

- Supports 16-bit up/down HyperTransport (HT) 3.0 interface up to 4.8 GT/s.
- Supports 200, 400, 600, 800, and 1000 MHz HT1 frequencies.
- Supports 1.6, 1.8, 2.0, 2.2, and 2.4 GHz HT3 frequencies.
- Supports AMD's AM3-socket CPUs, including the AMD Phenom II and later desktop processors.
- Supports LDTSTOP interface and CPU link stutter mode.

### 1.2.2 Memory Interface

- Supports an optional dedicated local frame buffer (side-port) of up to 128MB through a 16-bit interface. Note, however, that the memory interface is optimized for a 64MB local frame buffer. As such, the system BIOS will downsize the side-port size if a 128MB memory device is populated.
- New highly flexible memory architecture allows asymmetric side-port and shared system memory frame buffer sizes. Supported configurations include UMA only and UMA+side-port (interleave mode).
- New dynamic memory allocation scheme improves performance and reduces power simultaneously.
- Support for DDR2 system memories up to DDR2-1066, with a maximum memory clock speed of 533MHz. Memory clock is independent of any other clock source and can therefore be set to any frequency equal to or less than 533MHz (DDR2-1066), allowing the use of lower speed side-port memories.
- Support for DDR3 system memories up to DDR3-1333, with a maximum memory clock speed of 667MHz. Memory clock is independent of any other clock source and can therefore be set to any frequency equal to or less than 667MHz (DDR3-1333), allowing the use of lower speed side-port memories.
- Support one memory device of x16 width (see [section 2.2.1.1, "Supported DDR2 Components," on page 2-4](#) and [section 2.2.2.1, "Supported DDR3 Components," on page 2-5](#), for details).
- Asynchronous HyperTransport and memory controller interface speeds.
- Supports DDR SDRAM self refresh mechanism.
- Supports dynamic CKE and ODT for power conservation.

### 1.2.3 AMD HyperMemory™

- Supports AMD HyperMemory™\*.

\* **Note:** Includes dedicated and shared memory. The amount of HyperMemory available is determined by various factors. For details, please consult your AMD CSS representative.

### 1.2.4 PCI Express® Interface

- Supports PCIe Gen2 (version 2.0).

- Optimized peer-to-peer and general purpose link performance.
- Highly flexible PCI Express implementation to suit a variety of platform needs.
- A dual-port, x16 graphics interface, configurable to any one of the modes illustrated in *Figure 1-1*:

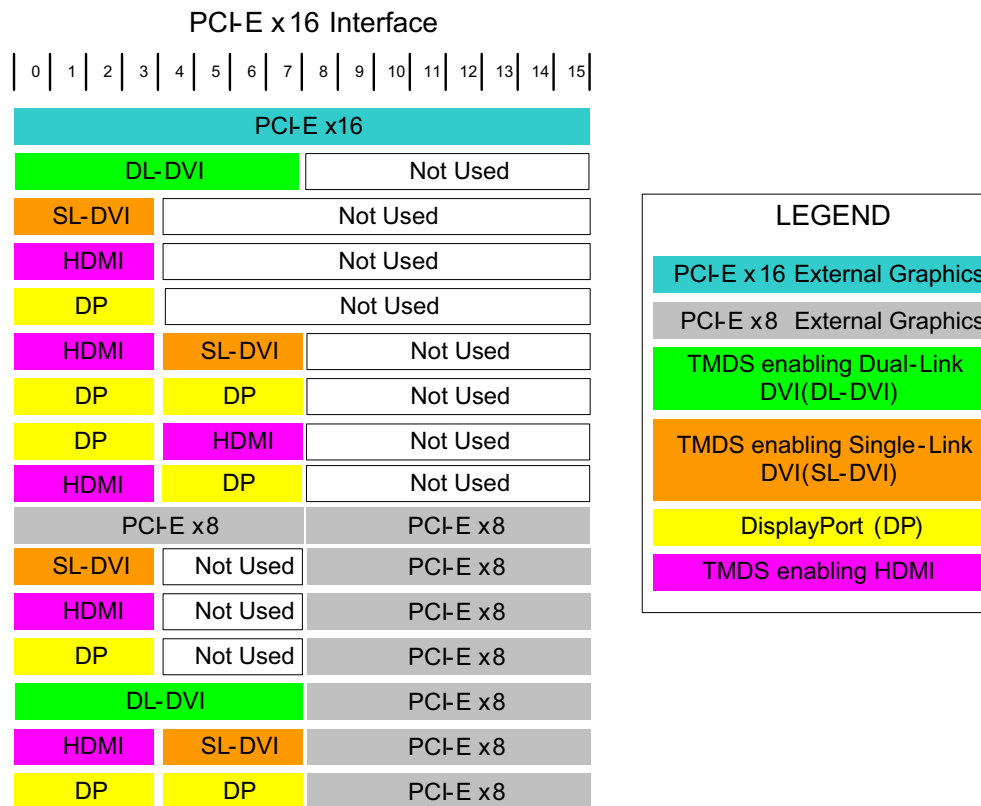

**Figure 1-1 Possible Configurations for the x16 PCIe® Graphics Interface**

- Supports programmable lane reversal for the graphics link to ease motherboard layout when the end device does not support lane reversal.
- Supports six general purpose lanes, for up to six devices on specific ports. Possible configurations are listed in *Table 1-1*.

**Table 1-1 Possible Configurations for the PCIe® General Purpose Links**

	Config. B	Config. C	Config. C2	Config. E	Config. K	Config. L
GPP1	x4	x4	x2	x2	x2	x1
GPP2	-	-	-	-	-	x1
GPP3	-	-	x2	x1	x2	x1
GPP4	-	-	-	x1	-	x1
GPP5	x2	x1	x2	x1	x1	x1
GPP6	-	x1	-	x1	x1	x1

- Supports x1, x2, x4, x8, x12 and x16 polarity inversion.

### 1.2.5 A-Link Express III Interface

- One x4 A-Link Express III interface for connection to an AMD Southbridge. The A-Link Express III is a proprietary interface developed by AMD basing on the PCI Express technology, with additional Northbridge-Southbridge messaging functionalities. It supports the PCIe Gen 2 transfer rate of 5 GT/s, and is backward compatible with the A-Link Express II interface.
- Supports programmable lane reversal to ease motherboard layout.

### 1.2.6 2D Acceleration Features

- Highly-optimized 128-bit engine, capable of processing multiple pixels per clock.
- Hardware acceleration of Bitblt, line drawing, polygon and rectangle fills, bit masking, monochrome expansion, panning and scrolling, scissoring, and full ROP support (including ROP3).
- Optimized handling of fonts and text using AMD proprietary techniques.
- Game acceleration including support for Microsoft's DirectDraw<sup>®</sup>: Double Buffering, Virtual Sprites, Transparent Blit, and Masked Blit.
- Acceleration in 1/8/15/16/32-bpp modes:
  - Pseudocolor mode for 8bpp
  - ARGB1555 and RGB565 modes for 16bpp
  - ARGB8888 mode for 32bpp
- Significant increase in the High-End Graphics WinBench<sup>®</sup> score due to capability for C18 color expansion.
- Setup of 2D polygons and lines.
- Support for GDI extensions:
  - In Windows XP and Windows Vista: Alpha BLT, Transparent BLT, and Gradient Fill.
  - In Windows 7: Alpha BLT, Transparent BLT, Color Fill BLT, Stretch BLT, and Clear Type BLT.
- Hardware cursor (up to 64x64x32bpp), with alpha channel for direct support of Windows XP, Windows Vista and Windows 7 alpha cursor.

### 1.2.7 3D Acceleration Features

- DirectX 10.1 compliant, including full speed 32-bit floating point per component operations
  - Shader Model 4.1 geometry and pixel support in a unified shader architecture:
    - Full speed 32-bit floating point processing per component.
    - High dynamic range rendering with floating point blending, texture filtering and anti-aliasing support.
    - High performance dynamic branching and flow control.
    - Nearly unlimited shader instruction store, using an advance caching system.
    - Advanced shader design, with ultra-threading sequencer for high efficiency operations.
    - Advanced, high performance branching support, including static and dynamic branching.
    - 32-bit floating point components for high dynamic range computations.
    - Full anti-aliasing on render surfaces up to and including 128-bit floating point formats.
- Support for OpenGL<sup>®</sup> 2.0
- Anti-Aliasing Filtering:
  - 2x/4x/8x modes.
  - Sparse multi-sample algorithm with gamma correction, programmable sample patterns, and centroid sampling.
  - Temporal anti-aliasing.
  - Adaptive anti-aliasing mode.
  - Lossless color compression (up to 8:1) at all resolutions, up to and including widescreen HDTV.
- Anisotropic Filtering:
  - 2x/4x/8x/16x modes

- Up to 128-tap texture filtering.
- Adaptive algorithm with performance (bi-linear) and quality (tri-linear) options.
- Improved quality mode due to improved subpixel precision, higher precision LOD computations, and rotationally invariant LOD computations.
- Advanced Texture Compression (3Dc+™):
  - High quality 4:1 compression for normal maps and luminance maps.
  - Works with any single-channel or two-channel data format.
- HW support to overcome "Small batch" issues in CPU limited applications.
- 3D resources virtualized to a 32-bit addressing space, for support of large numbers of render targets and textures.
- New vertex cache and vertex fetch design, to increase vertex throughput from previous generations.
- Full support of 64-bit and 128-bit textures and surfaces, which can be 4x to 8x faster than previous generation of HW.
- Up to 8K x 8K textures, including 128 bpp texture are supported.
- New multi-level texture cache to give optimal performance, greater than 8x the previous designs.
- High efficiency ring bus memory controller:
  - Programmable arbitration logic maximizes memory efficiency, software upgradeable.
  - Fully associative texture, color, and Z cache design.
  - New hierarchical Z and stencil buffers with early Z Test.
  - New lossless Z-buffer compression for both Z and stencil.
  - Fast Z-Buffer Clear.
  - Z cache optimized for real-time shadow rendering.
  - Z and color compression resources virtualized to a 32-bit addressing space, for support of multiple render targets and textures simultaneously.

### 1.2.8 Motion Video Acceleration Features

- Video scaling and fully programmable YCrCb to RGB color space conversion for full-speed video playback and fully adjustable color controls.
- Adaptive de-interlacing eliminates video artifacts caused by displaying interlaced video on non-interlaced displays, and by analyzing image and using optimal de-interlacing function on a per-pixel basis.
- Motion video acceleration for HD contents and Blu-ray technology.
- Dedicated UVD (Unified Video Decoder) 2.0 hardware for H.264, VC-1, and MPEG-2 decode:
  - H.264 implementation is based on the ISO/IEC 14496-10 spec.
  - VC-1 implementation is based on the SMPTE 421M spec.

### 1.2.9 Multiple Display Features

#### General

- Dual independent displays. Possible configurations are illustrated in [Figure 1-2](#).

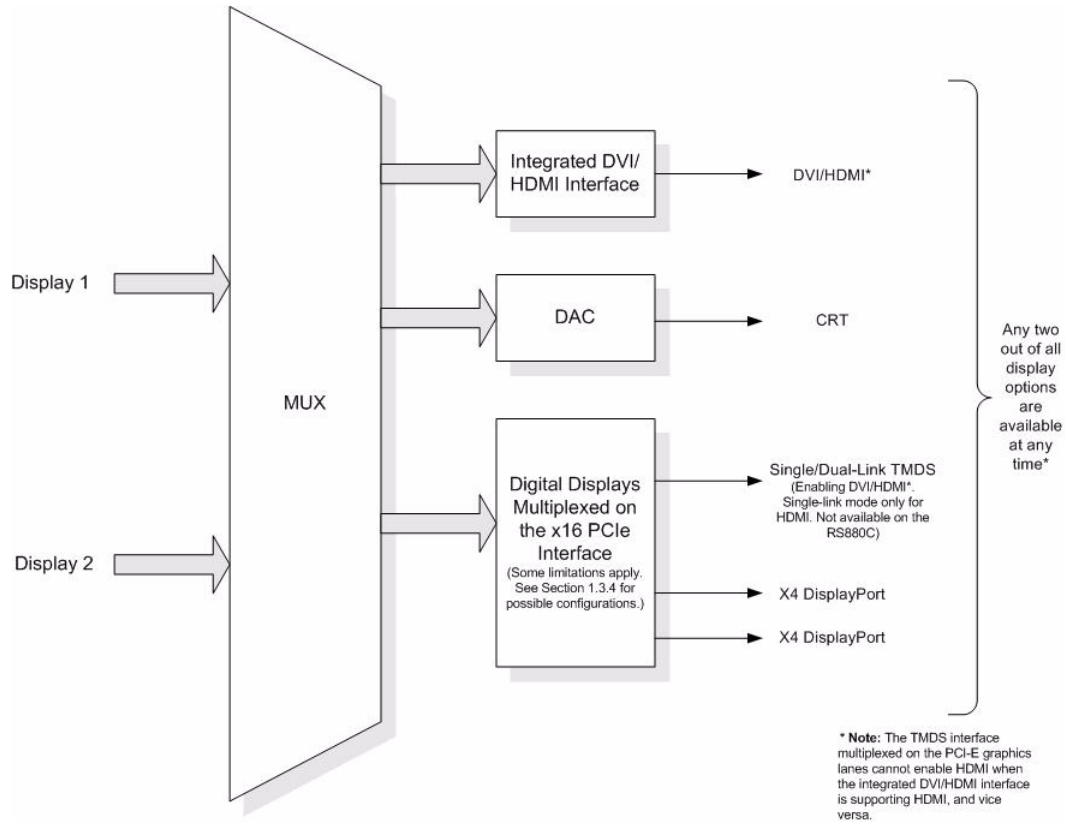

**Figure 1-2 RS880D Multiple Display Options**

- Resolution, refresh rates, and display data can be completely independent for the two display paths.
- Each display controller supports true 30 bits per pixel throughout the display pipe.
- Each display path supports VGA and accelerated modes, video overlay, hardware cursor, hardware icon, and palette gamma correction.
- Supports both interlaced and non-interlaced displays.
- Full ratiometric expansion ability is supported for source desktop modes up to 1920 pixels/line.
- Maximum DAC frequency of 400 MHz.
- Supports 8, 16, 32, and 64-bpp depths for the main graphics layer:
  - For 32-bpp depth, supports xRGB 8:8:8:8, xRGB 2:10:10:10, sCrYCb 8:8:8:8, and xCrYCb 2:10:10:10 data formats.
  - For 64-bpp depth, supports xRGB 16:16:16:16 data format.
- Independent gamma, color conversion and correction controls for main graphics layer.
- Support for DDC1 and DDC2B+ for plug and play monitors.
- 8-bit alpha blending of graphics and video overlay.
- Hardware cursor up to 64x64 pixels in 2 bpp, full color AND/XOR mix, and full color 8-bit alpha blend.
- Hardware icon up to 128x128 pixels in 2 bpp, with two colors, transparent, and inverse transparent. AND/XOR mixing. Supports 2x2 icon magnification.
- Virtual desktop support.
- Support for flat panel displays via VGA, DVI, or HDMI.
- Integrated HD audio controller for HDMI audio data.

### VGA Output

- Maximum resolutions supported by the VGA output for different refresh rates are:
  - 2048x1536 @85Hz (pixel clock at 388.5MHz) for 4:3 format
  - 2560x1440 @75Hz (pixel clock at 397.25MHz) for 16:9 format
  - 2456x1536 @60Hz (pixel clock at 320MHz) for 16:10 format
- Support for stereoscopic monitors.

### SurroundView™

- RS880D's SURROUNDVIEW™ feature allows support for up to six independent monitors for systems equipped with two ATI discrete graphics cards (requires special BIOS and display driver support).

### 1.2.10 DVI/HDMI™

- Integrated DVI or HDMI\* interface (passing HDMI CTS v1.3b): single-link support only for HDMI‡, 30-bit dual-link support for DVI.
- Also supports a TMDS interface, enabling DVI or HDMI (passing HDMI CTS v1.3b), which is multiplexed on the PCIe external graphics interface.‡
- 1620 Mbps/channel with 162 MHz pixel clock rate per link.
- Supports industry standard EIA-861B video modes including 480p, 720p, 1080i, and 1080p (for a full list of currently supported modes, contact your AMD CSS representative). Maximum resolutions supported by various modes are:
  - Single-link DVI: 1600x1200 @60Hz with standard timings, and 1920x1200 @60Hz with reduced blanking timings.
  - Dual-link DVI: 2560x1600 @60Hz.
  - HDMI: 1080p.
- Supports YCbCr 4:4:4 and 4:2:2 modes with HDMI.
- HDMI basic audio support at 32, 44.1 or 48 kHz. Supports two-channel uncompressed audio data, and, for Windows Vista platforms only, 5.1-channel audio data and DTS. HD audio device compatible with the Microsoft HD audio driver.
- HDCP support for two independent display streams with on-chip key storage. Also available when the integrated DVI/HDMI interface or the TMDS interface runs in dual-link mode.\*\*

**Notes:** \* CEC is not supported.

\*\* HDCP content protection support is only available to HDCP licensees and can only be enabled when connected to an HDCP-capable receiver.

‡ The TMDS interface multiplexed on the PCIe graphics lanes cannot enable HDMI when the integrated DVI/HDMI interface is supporting HDMI, and vice versa.

### 1.2.11 DisplayPort™ Interface

- Supports all mandatory features of the VESA DisplayPort Standard, Version 1.1, plus the following optional features:
  - 10-bit support.
  - YCbCr 4:4:4 and 4:2:2 support.
  - HDCP support
  - Optional test pattern support.
- Supports two independent displays over the PCIe interface for external graphics (see [Figure 1-1, "Possible Configurations for the x16 PCIe® Graphics Interface,"](#) on page 1-3 for details).
- Supports 4, 2, or 1-lane transmission.
- Supports both the 2.7 Gbps and 1.62 Gbps link symbol rates.

- Supports the Auxiliary Channel (AUX CH).
- Supports a maximum resolution of 2560x1600 @60Hz with 4 lanes.

### 1.2.12 Integrated HD Audio Controller and Codec

- Integrated HD Audio codec supports linear PCM and AC3 (5.1) audio formats for HDMI output.
- Separate logical chip function.
- Can encrypt data onto one associated HDMI output.
- Uses Microsoft UAA driver.
- Internally connected to the integrated HDMI, or HDMI-enabled interface, hence no external cable required.
- Support for basic audio (32, 44.1 or 48 KHz stereo) and AC3 or DTS at the same sample rates.

### 1.2.13 System Clocks

- Support for an external clock chip to generate side-port memory, PCIe, and A-Link Express III clocks. Alternatively, internal generation for these clocks, with clock input from an SB800-series Southbridge, can be used (subject to characterization with actual RS880D and SB800-series devices).

### 1.2.14 Power Management Features

- Single chip solution in 55nm, 1.1V CMOS technology.
- Full ACPI 2.0 and IAPC (Instantly Available PC) power management support.
- Static and dynamic power management support (APM as well as ACPI) with full VESA DPM and Energy Star compliance.
- The Chip Power Management Support logic supports four device power states defined for the OnNow Architecture—On, Standby, Suspend, and Off. Each power state can be achieved by software control bits.
- Hardware controlled intelligent clock gating enables clocks only to active functional blocks, and is completely transparent to software.
- Dynamic self-refresh for the side-port memory.
- Support for Cool'n'Quiet™ via FID/VID change.
- Support for AMD PowerNow!™.
- Clocks to every major functional block are controlled by a unique dynamic clock switching technique that is completely transparent to the software. By turning off the clock to the block that is idle or not used at that point, the power consumption can be significantly reduced during normal operation.
- Supports AMD Vari-Bright™ technology.
- Supports dynamic lane reduction for the PCIe graphics interface when coupled with an AMD-based graphics device, adjusting lane width according to required bandwidth.

### 1.2.15 PC Design Guide Compliance

The RS880D complies with all relevant Windows Logo Program (WLP) requirements from Microsoft for WHQL certification.

### 1.2.16 Test Capability Features

The RS880D has a variety of test modes and capabilities that provide a very high fault coverage and low DPM (Defect Per Million) ratio:

- Full scan implementation on the digital core logic through ATPG (Automatic Test Pattern Generation Vectors).
- Dedicated test logic for the on-chip custom memory macros to provide complete coverage on these modules.
- A JTAG test mode to allow board level testing of neighboring devices.
- An EXOR tree test mode on all the digital I/O's to allow for proper soldering verification at the board level.
- A VOH/VOL test mode on all digital I/O's to allow for proper verification of output high and output low values at the

board level.

- Access to the analog modules to allow full evaluation and characterization.
- IDDQ mode support to allow chip evaluation through current leakage measurements.

These test modes can be accessed through the settings on the instruction register of the JTAG circuitry.

### 1.2.17 Packaging

- Single chip solution in 55nm, 1.1V low power CMOS technology.
- 528-FCBGA package, 21mmx21mm.

## 1.3 Software Features

- Supports Microsoft Windows XP, Windows Vista, and Windows 7.
- BIOS ability to read EDID 1.1, 1.2, and 1.3.
- Ability to selectively enable and disable several devices including CRT, LCD, and DFP.
- Register-compatible with VGA standards, BIOS-compatible with VESA VBE2.0.
- Supports corporate manageability requirements such as DMI.
- ACPI support.
- Full Write Combining support for maximum performance of the CPU.
- Full-featured, yet simple Windows utilities:
  - Calibration utility for WYSIWYG color
  - Independent brightness control of desktop and overlay
  - End user diagnostics
- Drivers meet Microsoft's rigorous WHQL criteria and are suitable for systems with the "Designed for Windows" logos.
- Comprehensive OS and API support.
- Hot-key support (Windows ACPI 2.0 or AMD Event Handler Utility where appropriate).
- Extensive power management support.
- Rotation mode support in software.
- Dual CRT, simultaneous view, extended desktop support (Windows XP, Windows Vista, and Windows 7)
- DirectX 10.1 support.
- Switchable overlay support.
- H.264 playback support.
- Supports AMD OverDrive™ utility.

**\*\*\*Warning\*\*\*** AMD and ATI processors are intended to be operated only within their associated specifications and factory settings. Operating the AMD or ATI processor outside of specification or in excess of factory settings, including but not limited to overclocking, may damage the processor and/or lead to other problems, including but not limited to, damage to the system components (including the motherboard and components thereon (e.g. memory)), system instabilities (e.g. data loss and corrupted images), shortened processor, system component and/or system life and in extreme cases, total system failure. AMD does not provide support or service for issues or damages related to use of an AMD or ATI processor outside of processor specifications or in excess of factory settings.

- Supports Hybrid CrossFire™.

## 1.4 Branding Diagram

**Note:** The branding can be in laser, ink, or mixed laser-and-ink marking.

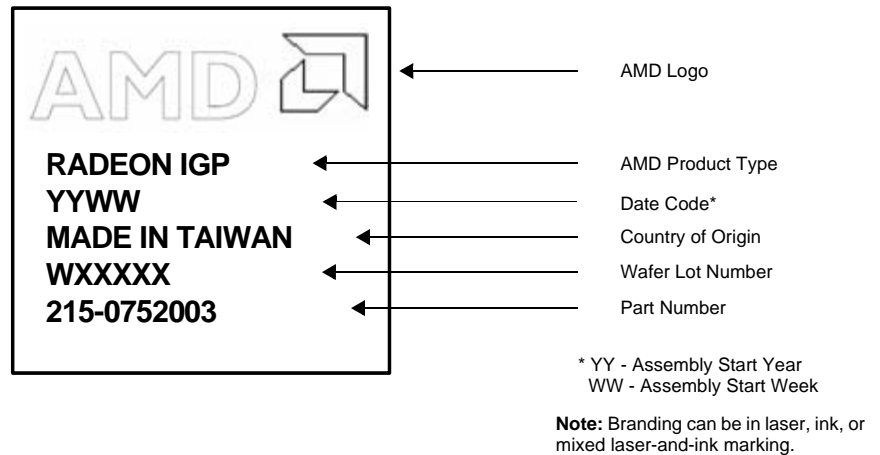

Figure 1-3 RS880D ASIC A11 Production Branding

## 1.5 Graphics Device ID and Graphics Engine Clock Speed

Table 1-2 Graphics Device ID and Graphics Engine Clock Speed

Variant	Graphics Device ID	Graphics Engine Clock Speed (MHz)	
		Min.	Max.
RS880D	0x9714	500	700

## 1.6 Conventions and Notations

The following conventions are used throughout this manual.

### 1.6.1 Pin Names

Pins are identified by their pin names or ball references. Multiplexed pins sometimes assume alternate “functional names” when they perform their alternate functions, and these “functional names” are given in *Chapter 3, “Pin Descriptions and Strap Options.”*

All active-low signals are identified by the suffix ‘#’ in their names (e.g., MEM\_RAS#).

### 1.6.2 Pin Types

The pins are assigned different codes according to their operational characteristics. These codes are listed in *Table 1-3.*

Table 1-3 Pin Type Codes

Code	Pin Type
I	Digital Input
O	Digital Output
OD	Open Drain
I/O	Bi-Directional Digital Input or Output
I/OD	Digital Input or Open Drain
M	Multifunctional
Pwr	Power
Gnd	Ground
A-O	Analog Output
A-I	Analog Input

**Table 1-3 Pin Type Codes (Continued)**

Code	Pin Type
A-I/O	Analog Bi-Directional Input/Output
A-Pwr	Analog Power
A-Gnd	Analog Ground
Other	Pin types not included in any of the categories above

### 1.6.3 Numeric Representation

Hexadecimal numbers are appended with “h” (Intel assembly-style notation) whenever there is a risk of ambiguity. Other numbers are in decimal.

Pins of identical functions but different running integers (e.g., “GFX\_TX7P, GFX\_TX6P,... GFX\_TX0P”) are referred to collectively by specifying their integers in square brackets and with colons (i.e., “GFX\_TX[7:0]P”). A similar short-hand notation is used to indicate bit occupation in a register. For example, NB\_COMMAND[15:10] refers to the bit positions 10 through 15 of the NB\_COMMAND register.

### 1.6.4 Register Field

A field of a register is referred to by the format of [Register Name].[Register.Field]. For example, “NB\_MC\_CNTL.DISABLE\_BYPASS” is the “DISABLE\_BYPASS” field of the register “NB\_MC\_CNTL.”

### 1.6.5 Hyperlinks

Phrases or sentences in *blue italic font* are hyperlinks to other parts of the manual. Users of the PDF version of this manual can click on the links to go directly to the referenced sections, tables, or figures.

### 1.6.6 Acronyms and Abbreviations

The following is a list of the acronyms and abbreviations used in this manual.

**Table 1-4 Acronyms and Abbreviations**

Acronym	Full Expression
ACPI	Advanced Configuration and Power Interface
A-Link-E	A-Link Express interface between the IGP and the Southbridge.
BGA	Ball Grid Array
BIOS	Basic Input Output System. Initialization code stored in a ROM or Flash RAM used to start up a system or expansion card.
BIST	Built In Self Test.
BLT	Blit
bpp	bits per pixel
CEC	Consumer Electronic Control
CPIS	Common Panel Interface Specification
CRT	Cathode Ray Tube
CSP	Chip Scale Package
DAC	Digital to Analog Converter
DBI	Dynamic Bus Inversion
DDC	Display Data Channel. A VESA standard for communicating between a computer system and attached display devices.
DDR	Double Data Rate
DFP	Digital Flat Panel. Monitor connection standard from VESA.
DP	DisplayPort
DPM	Defects per Million
DTV	Digital TV

Table 1-4 Acronyms and Abbreviations (Continued)

Acronym	Full Expression
DVD	Digital Video Disc
DVI	Digital Video Interface. Monitor connection standard from the DDWG (Digital Display Work Group).
DVS	Digital Video Stream
EPROM	Erasable Programmable Read Only Memory
FIFO	First In, First Out
FPDI	Flat Panel Display Interface
GDI	Graphics Device Interface
GND	Ground
GPIO	General Purpose Input/Output
HDCP	High-Bandwidth Digital Content Protection
HDMI	High Definition Multimedia Interface
HDTV	High Definition TV. The 1920x1080 and the 1280x720 modes defined by ATSC.
HPD	Hot Plug Detect
iDCT	inverse Discrete Cosine Transform
IDDQ	Direct Drain Quiescent Current
IGP	Integrated Graphics Processor. A single device that integrates a graphics processor and a system controller.
JTAG	Joint Test Access Group. An IEEE standard.
MB	Mega Byte
MPEG	Motion Pictures Experts Group. Refers to compressed video image streams in either MPEG-1 or MPEG-2 formats.
NTSC	National Television Standards Committee. The standard definition TV system used in North America and other areas.
PAL	Phase Alternate Line. The standard definition TV system used in Europe and other areas.
PCI	Peripheral Component Interface
PCIe	PCI Express
PLL	Phase Locked Loop
POST	Power On Self Test
PD	Pull-down Resistor
PU	Pull-up Resistor
ROP	Raster Operation
SDRAM	Synchronous Dynamic RAM
TMDS	Transition Minimized Differential Signaling
UMA	Unified Memory Architecture
UV	Chrominance (also CrCb). Corresponds to the color of a pixel.
UVD	Unified Video Decoder
UXGA	Ultra Extended Graphics Array
VBI	Vertical Blank Interval
VESA	Video Electronics Standards Association
VGA	Video Graphics Adapter
VRM	Voltage Regulation Module

# Chapter 2

## Functional Descriptions

This chapter describes the functional operation of the major interfaces of the RS880D system logic. *Figure 2-1, “RS880D Internal Block Diagram,”* illustrates the RS880D internal blocks and interfaces.

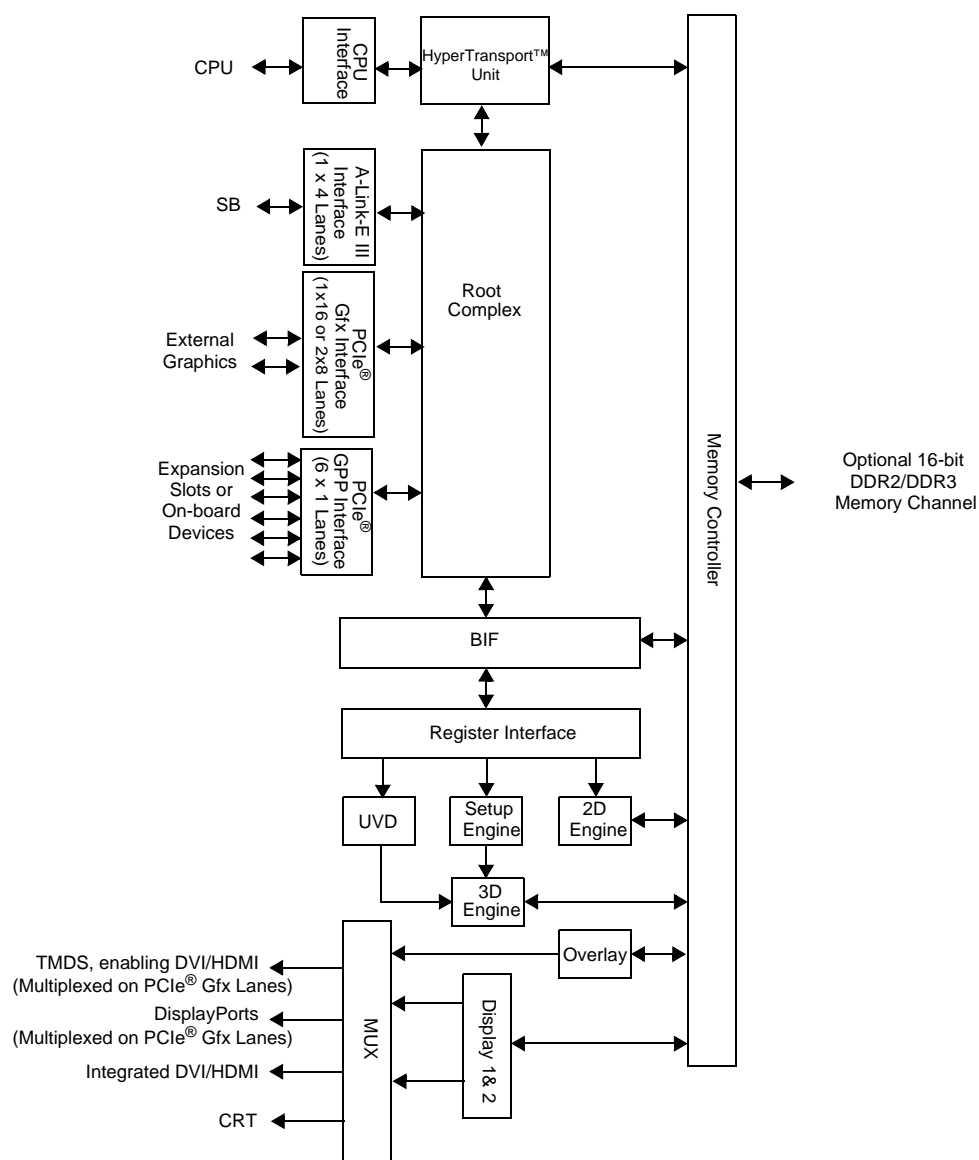
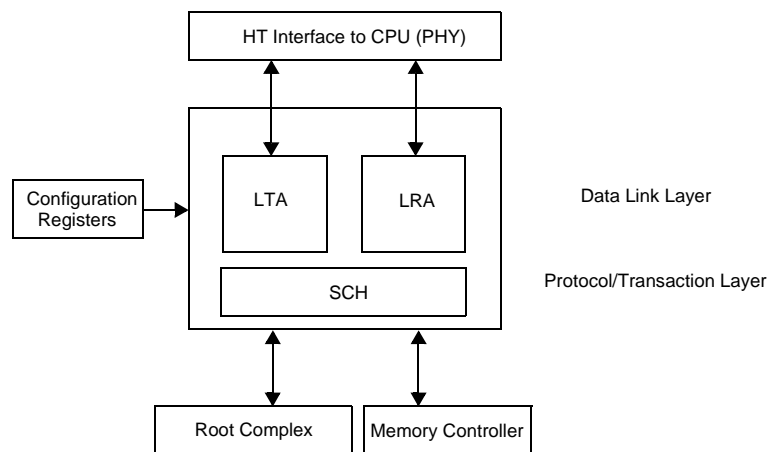

**Figure 2-1 RS880D Internal Block Diagram**

### 2.1 Host Interface

The RS880D is optimized to interface with AMD processors through the HyperTransport™ interface. This section presents an overview of the HyperTransport interface. For a detailed description of the interface, please refer to the

*HyperTransport I/O Link Specification* from the HyperTransport Consortium. *Figure 2-2, “Host Interface Block Diagram,”* illustrates the basic blocks of the host bus interface of the RS880D.



**Figure 2-2 Host Interface Block Diagram**

The HyperTransport (HT) Interface, formerly known as the LDT (Lightning Data Transport) interface, is a high speed, packet-based link implemented on two unidirectional buses. It is a point-to-point interface where data can flow both upstream and downstream at the same time. The commands, addresses, and data travel in packets on the HyperTransport link. Lengths of packets are in multiples of four bytes. The HT link consists of three parts: the physical layer (PHY), the data link layer, and the protocol/transaction layer. The PHY is the physical interface between the RS880D and the CPU. The data link layer includes the initialization and configuration sequences, periodic redundancy checks, connect/disconnect sequences, and information packet flow controls. The protocol layer is responsible for maintaining strict ordering rules defined by the HT protocol.

The RS880D HyperTransport bus interface consists of eighteen unidirectional differential data/control pairs and two differential clock pairs in each of the upstream and downstream direction. On power up, the HT link is 8-bit wide and runs at a default speed of 400MT/s. After negotiation, carried out by the HW and SW together, the link width can be brought up to 16-bit and the interface can run up to 4.8GT/s. The interface is illustrated in *Figure 2-3, “RS880D Host Bus Interface Signals.”* The signal name and direction for each signal is shown with respect to the processor. Note that the signal names may be different from those used in the pin listing of the RS880D. Detailed descriptions of the signals are given in *section 3.3, “CPU HyperTransport™ Interface,”* on page 3-5.

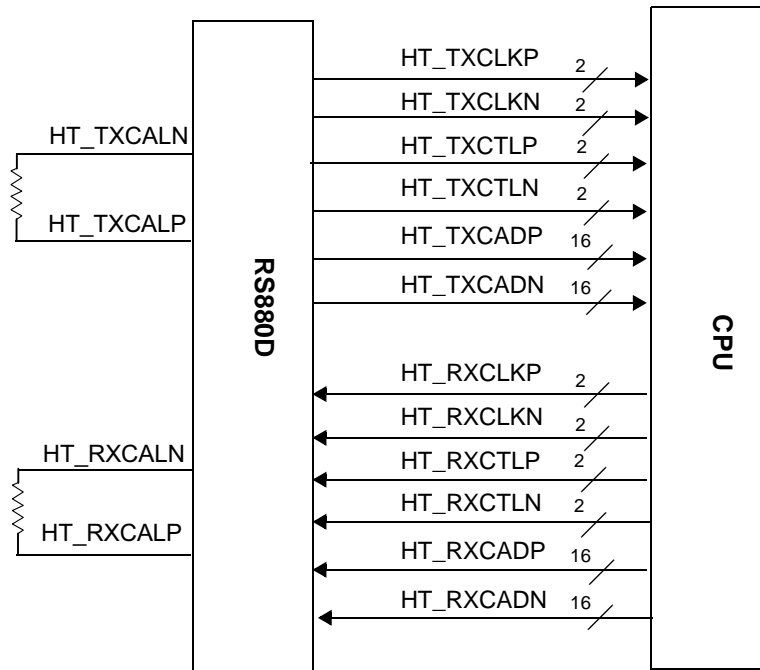

Figure 2-3 RS880D Host Bus Interface Signals

## 2.2 Side-Port Memory Interface

In order to significantly decrease system power and increase graphics performance, the RS880D provides an optional side-port memory interface for dedicated frame buffer memory, to be used exclusively for the integrated graphics core. The side-port memory interface can significantly reduce system power by allowing the CPU to stay in its lowest power state during periods of inactivity. Screen refreshes are fetched from the side-port memory, and there is no need to "wake up" the CPU to fetch screen refresh data.

The RS880D memory controller is unique and highly optimized. It operates in 16-bit mode at very high speed (up to DDR2-1066 and DDR3-1333), and has a programmable interleaved mode that significantly increases the memory bandwidth and reduces data latency to the integrated graphics core. The additional bandwidth provided to the internal graphics core will also aid the RS880D in reaching and exceeding Microsoft's Windows Vista® Premium logo requirements.

### 2.2.1 DDR2 Memory Interface

Figure 2-4, "RS880D Side-Port Memory Interface," on page 2-4 illustrates the side-port memory interface of the RS880D.

RS880D memory controller features and limitations:

- Supports a single memory device up to 128MB of physical size. However, as the memory interface is optimized for a 64MB local frame buffer, the system BIOS will downsize the side-port memory if a 128MB memory device is populated.
- Controls a single rank of DDR2 devices in 16-bit memory configuration.
- Supports device sizes of 256, 512, and 1024 Mbits, and a device width of x16.
- As the memory controller supplies only one chip select signal, only devices with one chip select are supported.
- A wide range of DDR2 timing parameters, configurations, and loadings are programmable via the RS880D memory controller configuration registers.

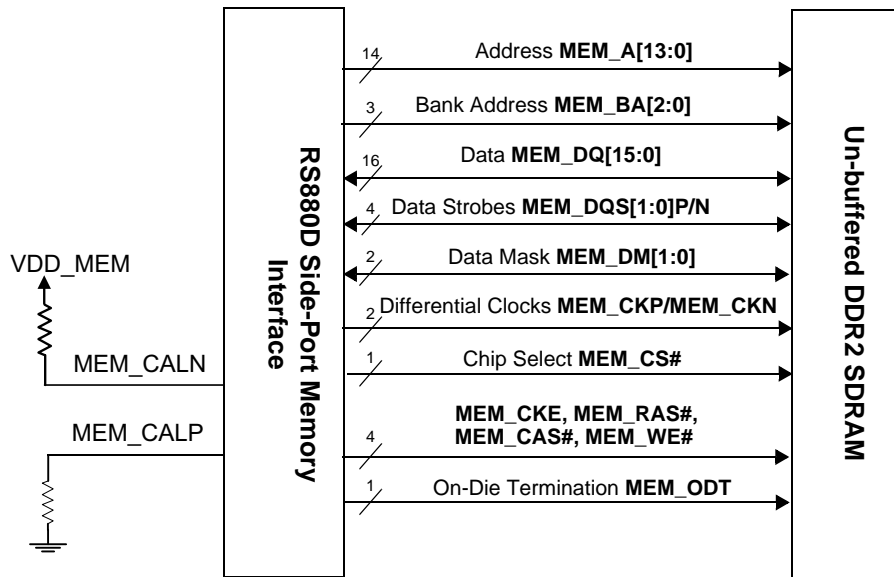

Figure 2-4 RS880D Side-Port Memory Interface

2.2.1.1 Supported DDR2 Components

The memory controller supports DDR2 SDRAM chips in several configurations. These chips are organized in banks, rows (or pages), and columns. The supported DDR2 components have four or eight banks. Table 2-1 lists the supported memory components.

Table 2-1 Supported DDR2 Components

DDR2 SDRAM						Mbytes
Config	Mbits	CS Mode	Bank Bits	Row Bits	Col Bits	
16Mbx16	256	4	2	13	9	32
32Mbx16	512	10	2	13	10	64
64Mbx16	1024	11	3	13	10	128
128Mbx16	2048	7	3	14	10	256

2.2.1.2 Row and Column Addressing

Table 2-2 shows how the physical address P (after taking out the bank bit) is used to provide the row and column addressing for each size of DDR2 memories.

Table 2-2 DDR2 Memory Row and Column Addressing

Address														
	A13	A12	A11	A10	A9	A8	A7	A6	A5	A4	A3	A2	A1	A0
16Mbx16 devices														
Row		P10	P14	P13	P12	P11	P22	P21	P20	P19	P18	P17	P16	P15
Column		-	-	PC	-	P9	P8	P7	P6	P5	P4	P3	P2	P1
32Mbx16 devices														
Row		P23	P14	P13	P12	P11	P22	P21	P20	P19	P18	P17	P16	P15
Column		-	-	PC	P10	P9	P8	P7	P6	P5	P4	P3	P2	P1

Address														
	A13	A12	A11	A10	A9	A8	A7	A6	A5	A4	A3	A2	A1	A0
<b>64Mbx16 devices</b>														
Row		P23	P14	P13	P12	P11	P22	P21	P20	P19	P18	P17	P16	P15
Column		-	-	PC	P10	P9	P8	P7	P6	P5	P4	P3	P2	P1
<b>128Mbx16 devices</b>														
Row	P24	P23	P14	P13	P12	P11	P22	P21	P20	P19	P18	P17	P16	P15
Column		-	-	PC	P10	P9	P8	P7	P6	P5	P4	P3	P2	P1

Note: PC = precharge flag

## 2.2.2 DDR3 Memory Interface

RS880D memory controller features and limitations:

- Supports a single memory device up to 128MB of physical size. However, as the memory interface is optimized for a 64MB local frame buffer, the system BIOS will downsize the side-port memory if a 128MB memory device is populated.
- Supports a single rank of DDR3 device in 16-bit memory configuration.
- Supports device sizes of 512 and 1024 Mbits, and a device width of x16.
- A wide range of DDR3 timing parameters, configurations, and loadings are programmable via the RS880D memory controller configuration registers.

### 2.2.2.1 Supported DDR3 Components

The memory controller supports DDR3 SDRAM chips in several configurations. These chips are organized in banks, rows (or pages), and columns. [Table 2-3](#) lists the supported memory components.

**Table 2-3 Supported DDR3 Components**

DDR3 SDRAM						Mbytes
Config	Mbits	CS Mode	Bank Bits	Row Bits	Col Bits	
32Mbx16	512	9	3	12	10	64
64Mbx16	1024	11	3	13	10	128

### 2.2.2.2 Row and Column Addressing

[Table 2-4](#) shows how the physical address P (after taking out the bank bit) is used to provide the row and column addressing for each size of DDR3 memories.

**Table 2-4 DDR3 Memory Row and Column Addressing**

Address														
	A13	A12	A11	A10	A9	A8	A7	A6	A5	A4	A3	A2	A1	A0
<b>32Mbx16 devices</b>														
Row		P23	P14	P13	P12	P11	P22	P21	P20	P19	P18	P17	P16	P15
Column		-	-	PC	P10	P9	P8	P7	P6	P5	P4	P3	P2	P1
<b>64Mbx16 devices</b>														
Row		P23	P14	P13	P12	P11	P22	P21	P20	P19	P18	P17	P16	P15
Column		-	-	PC	P10	P9	P8	P7	P6	P5	P4	P3	P2	P1

Note: PC = precharge flag

## 2.3 DVI/HDMI™

### 2.3.1 DVI/HDMI™ Data Transmission Order and Signal Mapping

The RS880D contains an integrated DVI/HDMI interface and a TMDS interface (multiplexed on the PCI Express® graphics lanes), both supporting clock frequencies of up to 162 MHz for each signal link. The multiplexing relationships between the PCIe external graphics signals and the TMDS signals are given in [section 3.9, “TMDS Interface Multiplexed on the PCI Express® Graphics Lanes,” on page 3-9](#). [Figure 2-5](#) below shows the transmission ordering of the signals on both interfaces in single-link mode.

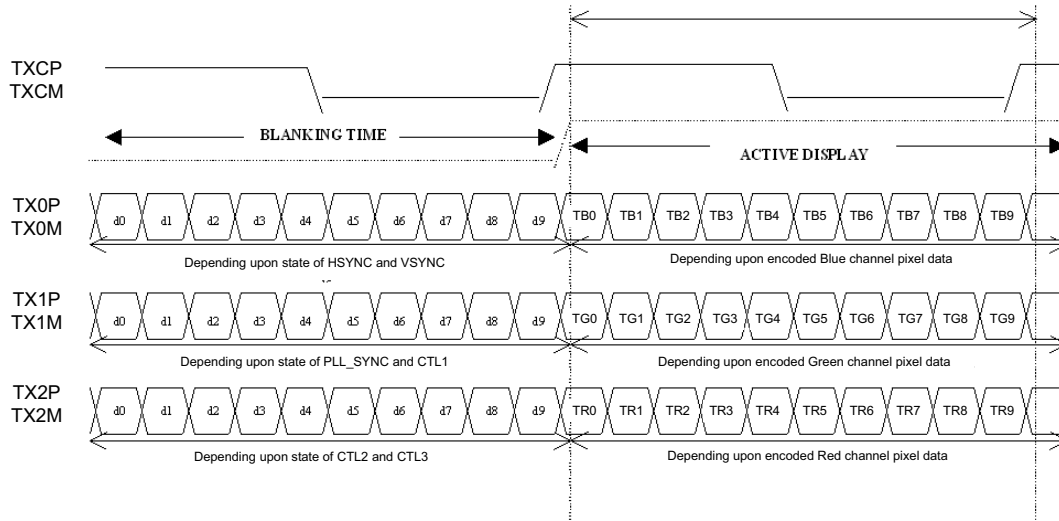

**Figure 2-5 Data Transmission Ordering for the Integrated DVI/HDMI™ and TMDS Interfaces**

For dual-link mode, which is for DVI only, the same transmission order applies to data channels on the second link, with the first link transmitting data for even pixels and the second link for odd pixels. See [Table 2-6](#) below for details.

The signal mapping for the transmission is shown in [Table 2-5](#) (single link) and [Table 2-6](#) (dual-link DVI) below.

Table 2-5 Single Link Signal Mapping for DVI/HDMI™

DVI/HDMI™ Functional Name	Data Phase	Signal
TX0M/P	Phase 1	B0
	Phase 2	B1
	Phase 3	B2
	Phase 4	B3
	Phase 5	B4
	Phase 6	B5
	Phase 7	B6
	Phase 8	B7
	Phase 9	B8
	Phase 10	B9
TX1M/P	Phase 1	G0
	Phase 2	G1
	Phase 3	G2
	Phase 4	G3
	Phase 5	G4
	Phase 6	G5
	Phase 7	G6
	Phase 8	G7
	Phase 9	G8
	Phase 10	G9
TX2M/P	Phase 1	R0
	Phase 2	R1
	Phase 3	R2
	Phase 4	R3
	Phase 5	R4
	Phase 6	R5
	Phase 7	R6
	Phase 8	R7
	Phase 9	R8
	Phase 10	R9

**Note:** HVSYNC are transmitted on TX0M/P (Blue) channel during blank.

Table 2-6 Dual-Link Signal Mapping for DVI

Link 1			Link 2		
DVI Functional Name	Data Phase	Signal	DVI Functional Name	Data Phase	Signal
TX0M/P	Phase 1	EVEN_B0	TX3M/P	Phase 1	ODD_B0
	Phase 2	EVEN_B1		Phase 2	ODD_B1
	Phase 3	EVEN_B2		Phase 3	ODD_B2
	Phase 4	EVEN_B3		Phase 4	ODD_B3
	Phase 5	EVEN_B4		Phase 5	ODD_B4
	Phase 6	EVEN_B5		Phase 6	ODD_B5
	Phase 7	EVEN_B6		Phase 7	ODD_B6
	Phase 8	EVEN_B7		Phase 8	ODD_B7
	Phase 9	EVEN_B8		Phase 9	ODD_B8
	Phase 10	EVEN_B9		Phase 10	ODD_B9
TX1M/P	Phase 1	EVEN_G0	TX4M/P	Phase 1	ODD_G0
	Phase 2	EVEN_G1		Phase 2	ODD_G1
	Phase 3	EVEN_G2		Phase 3	ODD_G2
	Phase 4	EVEN_G3		Phase 4	ODD_G3
	Phase 5	EVEN_G4		Phase 5	ODD_G4
	Phase 6	EVEN_G5		Phase 6	ODD_G5
	Phase 7	EVEN_G6		Phase 7	ODD_G6
	Phase 8	EVEN_G7		Phase 8	ODD_G7
	Phase 9	EVEN_G8		Phase 9	ODD_G8
	Phase 10	EVEN_G9		Phase 10	ODD_G9
TX2M/P	Phase 1	EVEN_R0	TX5M/P	Phase 1	ODD_R0
	Phase 2	EVEN_R1		Phase 2	ODD_R1
	Phase 3	EVEN_R2		Phase 3	ODD_R2
	Phase 4	EVEN_R3		Phase 4	ODD_R3
	Phase 5	EVEN_R4		Phase 5	ODD_R4
	Phase 6	EVEN_R5		Phase 6	ODD_R5
	Phase 7	EVEN_R6		Phase 7	ODD_R6
	Phase 8	EVEN_R7		Phase 8	ODD_R7
	Phase 9	EVEN_R8		Phase 9	ODD_R8
	Phase 10	EVEN_R9		Phase 10	ODD_R9

**Notes:**

- H/VSYNC are transmitted on TX0M/P (Blue) channel during blank.
- For DVI dual-link mode, the first active data pixel is defined as pixel#0 (an even pixel), as opposed to the DVI specifications.

## 2.3.2 Support for HDMI™ Packet Types

Table 2-7 Support for HDMI™ Packet Type

Packet Value	Packet Type	Supported or Not	Source	Comment	
0x00	Null	Yes	Inserted by hardware when needed.	Sent when required to meet maximum time between data island specification.	
0x01	Audio Clock Regeneration	Yes	Inserted by hardware as required.	—	
0x02	Audio Sample	Yes	Audio samples come from HD audio DMA. Channel status from HD audio and video registers. Inserted in horizontal blank whenever audio FIFO contains data.	—	
0x03	General Control	No	Sending and contents controlled by video driver.	—	
0x04	ACP Packet	No	—	—	
0x05	ISRC1 Packet	No	—	—	
0x06	ISRC2 Packet	No	—	—	
0x07	Reserved	N/A	N/A	N/A	
InfoFrame Packet Type					
HDMI™ ID	EIA-861B ID				
0x80	0x00	Vendor-Specific	Yes*	—	—
0x81	0x01	AVI	Yes	Inserted on line selected by software.	For colorimetry, repetition count, video format, picture formatting.
0x82	0x02	Source Product Descriptor	Yes*	—	—
0x83	0x03	Audio	Yes	Inserted on line selected by software. Contents from registers written by video and HD audio drivers.	For channel counts, sampling frequency, etc.
0x84	0x04	MPEG Source	No	—	According to the CEA-861 specification, MPEG Source InfoFrames should not be used.

\* **Note:** These packet types are supported using generic packet types. A maximum of two of them can be supported simultaneously.

## 2.4 VGA DAC Characteristics

**Table 2-8 VGA DAC Characteristics**

Parameter	Min	Typ	Max	Notes
Resolution	10 bits	-	-	1
Maximum PS/2 setting Output Voltage	-	0.7V	-	1
Maximum PS/2 setting Output Current	-	18.7mA	-	1
Full Scale Error	+8% / -3%	-	+10%	2, 3
DAC to DAC Correlation	-2%	-	+2%	1, 4
Differential Linearity	-2 LSB	-	+2 LSB	1, 5
Integral Linearity	-2 LSB	-	+2 LSB	1, 5
Rise Time (10% to 90%)	0.58ns	-	1.7ns	1, 6
Full Scale Settling Time	-	TBA	-	1, 7, 8
Glitch Energy	-	TBA	-	1, 8
Monotonicity	-	-	-	9

**Notes:**

- 1 - Tested over the operating temperature range at nominal supply voltage, with an Iref of -1.50mA (Iref is the level of the current flowing out of the RSET resistor).
- 2 - Tested over the operating temperature range at reduced supply voltage, with an Iref of -1.50mA (Iref is the level of the current flowing out of the Rset resistor).
- 3 - Full scale error from the value predicted by the design equations.
- 4 - About the mid-point of the distribution of the three DACs measured at full scale deflection.
- 5 - Linearity measured from the best fit line through the DAC characteristics. Monotonicity guaranteed.
- 6 - Load = 37.5Ω + 20 pF with Iref = -1.50 mA (Iref is the current flowing out of the Rset resistor).
- 7 - Measured from the end of the overshoot to the point where the amplitude of the video ringing is down to +/-5% of the final steady state value.
- 8 - This parameter is sampled, not 100% tested.
- 9 - Monotonicity is guaranteed.

## 2.5 Clock Generation

The RS880D provides support for an external clock chip to generate side-port memory, PCIe, and A-Link Express III clocks. Alternatively, internal generation for these clocks, with clock input from an SB800-series Southbridge, can be implemented (subject to characterization with actual RS880D and SB800-series devices). For information on the supported external clock chips and on the internal clock generator, please consult your AMD CSS representative.

---

# Chapter 3

## Pin Descriptions and Strap Options

---

This chapter gives the pin descriptions and the strap options for the RS880D. To jump to a topic of interest, use the following list of hyperlinked cross references:

- [“Pin Assignment Top View” on page 3-2](#)
- [“Interface Block Diagram” on page 3-4](#)
- [“CPU HyperTransport™ Interface” on page 3-5](#)
- [“Side-port Memory Interface” on page 3-5](#)
- [“PCI Express® Interfaces” on page 3-6:](#)
  - [“1 x 16 Lane Interface for External Graphics” on page 3-6](#)
  - [“A-Link Express III Interface for Southbridge” on page 3-6](#)
  - [“6 x 1 Lane Interface for General Purpose External Devices” on page 3-6](#)
  - [“Miscellaneous PCI Express® Signals” on page 3-6](#)
- [“Clock Interface” on page 3-7](#)
- [“CRT Interface” on page 3-7](#)
- [“Integrated DVI/HDMI™ Interface” on page 3-8](#)
- [“TMDS Interface Multiplexed on the PCI Express® Graphics Lanes” on page 3-9](#)
- [“DisplayPort™ Interface” on page 3-10](#)
- [“Power Management Pins” on page 3-11](#)
- [“Miscellaneous Pins” on page 3-11](#)
- [“Power Pins” on page 3-12](#)
- [“Ground Pins” on page 3-13](#)
- [“Strapping Options” on page 3-14](#)

### 3.1 Pin Assignment Top View

#### 3.1.1 RS880D Pin Assignment Top View

The figures below only represent the relative ball positions. For the actual physical layout of the balls, please refer to *Figure 5-3, “RS880D Ball Arrangement (Bottom View),”* on page 5- 9.

	1	2	3	4	5	6	7	8	9	10	11	12	13
A		VSSAPCIE	GFX_RX1P	GFX_TX1P	GFX_TX0P	VDDPCIE	DDC_DATA1/AUX1N	DDC_CLK0/AUX0P	I2C_DATA	POWERGOOD	DAC_HSYNC	PLLVD	VDDLTP18
B	VSSAPCIE	GFX_TX2N	GFX_RX1N	GFX_TX1N	GFX_TX0N	VDDPCIE	DDC_CLK1/AUX1P	DDC_DATA0/AUX0N	I2C_CLK	STRP_DATA	DAC_VSYNC	PLLVSS	VSSLTP18
C	GFX_RX2N	GFX_RX2P	GFX_TX2P	GFX_RX0N		VDDPCIE		AUX_CAL		LDTSTOP#		ALLOW_LDTSTOP	
D	GFX_TX3P	GFX_TX3N	VSSAPCIE	GFX_RX0P	VSSAPCIE	VDDPCIE	VDDA18PCIEP_LL	SYSRESET#	TMDS_HPD	HPD	VSS	SUS_STAT#	TESTMODE
E	GFX_TX4N	GFX_TX4P		VSSAPCIE	GFX_RX3P	VDDPCIE	VDDA18PCIEP_LL	DAC_SDA	GPIO3		REFCLK_P	AVDD	
F	GFX_TX6P	GFX_TX6N	GFX_TX5N	GFX_TX5P	GFX_RX3N	VDDPCIE	GPIO2	DAC_SCL	VDD18		REFCLK_N	AVDD	
G	VSSAPCIE	VSSAPCIE		VSSAPCIE	GFX_RX4P	GFX_RX4N	VDDPCIE	VSS	VDD18		RESERVED	GPIO4	
H	GFX_TX8P	GFX_TX8N	GFX_TX7N	GFX_TX7P	GFX_RX5P	GFX_RX5N	VSSAPCIE	VDDPCIE	VDDA18PCIE		VDD33	VDD33	
J	GFX_TX9N	GFX_TX9P		VSSAPCIE	GFX_RX6N	GFX_RX6P	GFX_RX7P	GFX_RX7N	VDDPCIE	VDDA18PCIE	VDDC	VSS	
K	GFX_TX11P	GFX_TX11N	GFX_TX10N	GFX_TX10P					VDDPCIE	VDDA18PCIE	VSS	VDDC	
L	VSSAPCIE	VSSAPCIE		VSSAPCIE	GFX_RX8P	GFX_RX8N	VSSAPCIE	GFX_RX9N	VDDPCIE	VDDA18PCIE	VDDC	VSS	
M	GFX_TX13P	GFX_TX13N	GFX_TX12N	GFX_TX12P	GFX_RX11N	VSSAPCIE	GFX_RX10N	GFX_RX9P	VDDPCIE	VDDA18PCIE	VSS	VDDC	VDDC
N	GFX_TX14N	GFX_TX14P		VSSAPCIE								VDDC	VSS
P	GFX_TX15P	GFX_TX15N	GFX_RX14N	GFX_RX14P	GFX_RX11P	VSSAPCIE	GFX_RX10P	GFX_RX12N	VDDPCIE	VDDA18PCIE	VDDC	VSS	VDDC
R	VSSAPCIE	VSSAPCIE		VSSAPCIE	GFX_RX13N	GFX_RX13P	VSSAPCIE	GFX_RX12P	VDDPCIE	VDDA18PCIE	VSS	VDDC	
T	GFX_REFCLK_N	GFX_REFCLK_P	GFX_RX15N	GFX_RX15P					VDDPCIE	VDDA18PCIE	VDDC	VSS	
U	GPP_REFCLK_P	GPP_REFCLK_N		VSSAPCIE	GPP_RX4P	GPP_RX4N	GPP_RX5N	GPP_RX5P	VDDPCIE	VDDA18PCIE	VSS	VDDC	
V	GPP_TX5P	GPP_TX5N	GPPSB_REFC_LKN	GPPSB_REFC_LKP	GPP_RX3P	VSSAPCIE	VSSAPCIE	VSSAPCIE	VDDPCIE		MEM_A2	VSS	
W	VSSAPCIE	VSSAPCIE		VSSAPCIE	SB_RX3P	GPP_RX3N	VSSAPCIE	VSSAPCIE	VDDA18PCIE		VSS	MEM_RAS#	
Y	GPP_TX3P	GPP_TX3N	GPP_TX4N	GPP_TX4P	SB_RX3N	VSSAPCIE	SB_RX1N	SB_RX0N	VDDA18PCIE		VDD_MEM	MEM_CAS#	
AA	GPP_TX2N	GPP_TX2P		VSSAPCIE	SB_RX2P	SB_RX2N	SB_RX1P	SB_RX0P	VDDA18PCIE		VDD_MEM	MEM_A4	
AB	VSSAPCIE	VSSAPCIE	GPP_TX1N	GPP_TX1P	VSSAPCIE	SB_TX2P	VSSAPCIE	PCE_CALRN	VDDA18PCIE	VDD_MEM	VSS	MEM_A0	MEM_CS#
AC	GPP_TX0P	GPP_TX0N	VSSAPCIE	VSSAPCIE		SB_TX2N		PCE_CALRP		VDD_MEM		VSS	
AD	GPP_RX2P	GPP_RX2N	GPP_RX1N	GPP_RX0N	SB_TX3P	SB_TX1N	SB_TX0P	THERMALDIO_DE_N	VDDA18PCIE	VDD_MEM	VDD18_MEM	MEM_COMPN	MEM_A8
AE	VSSAPCIE	GPP_RX1P	GPP_RX0P	VSSAPCIE	SB_TX3N	SB_TX1P	SB_TX0N	THERMALDIO_DE_P	VDDA18PCIE	VDD_MEM	VDD18_MEM	MEM_COMPN	MEM_A11
	1	2	3	4	5	6	7	8	9	10	11	12	13













	CPU Interface
	A-Link Express III Interface
	Clock Interface
	Side-port Memory Interface
	CRT Interface
	External graphics Interface
	Integrated DVI/HDMI Interface
	General Purpose External Device Interface
	Power Management Interface
	Powers
	Grounds
	Others

Figure 3-1 RS880D Pin Assignment Top View (Left)

14	15	16	17	18	19	20	21	22	23	24	25	
VDDL33	VDDL18	TXCLK_LN	TXOUT_U1P	TXOUT_U0N	TXOUT_L3P	TXOUT_L2N	TXOUT_L1P	TXOUT_L0P	VDDHTRX	HT_RXCALN	VSSAHT	A
VDDL33	VDDL18	TXCLK_LP	TXOUT_U1N	TXOUT_U0P	TXOUT_L3N	TXOUT_L2P	TXOUT_L1N	TXOUT_L0N	VDDHTRX	HT_TXCALP	HT_TXCALN	B
VSSLT		VSSLT		VSSLT		VSSLT		VSSLT	HT_RXCALP	HT_REFCLKN	HT_REFCLKP	C
PLLVDD18	VSSLT	TXCLK_UP	TXCLK_UN	TXOUT_U3P	TXOUT_U3N	TXOUT_U2P	TXOUT_U2N	VDDHTRX	VSSAHT	HT_TXCAD0P	HT_TXCAD0N	D
VSS	VSS		RESERVED	GREEN	BLUE	VSSLT	VDDHTRX	VSSAHT		HT_TXCAD1P	HT_TXCAD1N	E
AVDDDI	RESERVED		RESERVED	GREEN#	BLUE#	VDDHTRX	HT_TXCAD8P	HT_TXCAD3N	HT_TXCAD3P	HT_TXCAD2P	HT_TXCAD2N	F
DAC_RSET	AVSSDI		RED#	RED	VDDHTRX	HT_TXCAD9P	HT_TXCAD8N	VSSAHT		VSSAHT	VSSAHT	G
AVSSQ	AVDDO		VDDA18HTPLL	VDDHTRX	VSSAHT	VSSAHT	HT_TXCAD9N	HT_TXCAD4N	HT_TXCAD4P	HT_TXCLK0P	HT_TXCLK0N	H
VDDC	VSS	VDDC	VDDHT	HT_TXCAD11P	HT_TXCAD12N	HT_TXCAD10P	HT_TXCAD10N	VSSAHT		HT_TXCAD5N	HT_TXCAD5P	J
VSS	VDDC	VDDHT	HT_TXCAD11N					HT_TXCAD7N	HT_TXCAD7P	HT_TXCAD6P	HT_TXCAD6N	K
VDDC	VSS	VDDHT	VSSAHT	HT_TXCAD13N	HT_TXCAD12P	HT_TXCLK1N	HT_TXCLK1P	VSSAHT		VSSAHT	VSSAHT	L
VSS	VDDC	VDDHT	VDDHTTX	HT_TXCAD15N	HT_TXCAD13P	VSSAHT	HT_TXCAD14P	HT_RXCTL0P	HT_RXCTL0N	HT_TXCTL0P	HT_TXCTL0N	M
VDDC								VSSAHT		HT_RXCAD7P	HT_RXCAD7N	N
VDDC	VSS	VDDHT	VDDHTTX	HT_TXCAD15P	HT_TXCTL1P	VSSAHT	HT_TXCAD14N	HT_RXCAD5P	HT_RXCAD5N	HT_RXCAD6N	HT_RXCAD6P	P
VSS	VDDC	VDDHT	VDDHTTX	HT_TXCTL1N	VSSAHT	HT_RXCTL1N	HT_RXCTL1P	VSSAHT	VSSAHT	VSSAHT	VSSAHT	R
VDDC	VDDC	VDDHT	VDDHTTX					HT_RXCLK0P	HT_RXCLK0N	HT_RXCAD4N	HT_RXCAD4P	T
VSS	VSS	VDDC	VDDHTTX	HT_RXCAD15	HT_RXCAD15	HT_RXCAD14	HT_RXCAD14	VSSAHT		HT_RXCAD3P	HT_RXCAD3N	U
MEM_ODT	MEM_CK0		MEM_DQ4	VDDHTTX	VSSAHT	HT_RXCAD13	HT_RXCAD13	HT_RXCAD1P	HT_RXCAD1N	HT_RXCAD2N	HT_RXCAD2P	V
MEM_CK1	VSS		MEM_DM0	MEM_DQS0N	VDDHTTX	HT_RXCAD12	HT_RXCAD12	VSSAHT		VSSAHT	VSSAHT	W
MEM_A13	MEM_DQ7		MEM_DQS0P	VSS	MEM_DQ3	VDDHTTX	VSSAHT	HT_RXCAD11P	HT_RXCAD11N	HT_RXCAD0N	HT_RXCAD0P	Y
VSS	MEM_DQ6		MEM_DQ5	MEM_DQ0	MEM_DQ2	MEM_DQ1	VDDHTTX	HT_RXCLK1N		HT_RXCAD10	HT_RXCAD10	AA
MEM_A6	VSS	MEM_A5	VSS	MEM_CKE	VSS	MEM_DQ12	VSS	VDDHTTX	HT_RXCLK1P	HT_RXCAD9N	HT_RXCAD9P	AB
MEM_A12		MEM_A10		MEM_DQ11		MEM_DQ8		MEM_DQ14	VDDHTTX	HT_RXCAD8P	HT_RXCAD8N	AC
MEM_A7	MEM_A9	MEM_BA0	MEM_BA2	MEM_WE#	MEM_DQ9	MEM_DQS1P	MEM_DQ15	MEM_DQ13	IOPLLSS	VDDHTTX	VSSAHT	AD
VSS	MEM_A3	MEM_A1	MEM_BA1	MEM_VREF	MEM_DM1	VSS	MEM_DQS1N	MEM_DQ10	IOPLLVDD18	IOPLLVDD	VDDHTTX	AE
14	15	16	17	18	19	20	21	22	23	24	25	

	CPU Interface
	A-Link Express III Interface
	Clock Interface
	Side-port Memory Interface
	CRT Interface
	External graphics Interface
	Integrated DVI/HDMI Interface
	General Purpose External Device Interface
	Power Management Interface
	Powers
	Grounds
	Others

Figure 3-2 RS880D Pin Assignment Top View (Right)

### 3.2 Interface Block Diagram

Figure 3-3 shows the different interfaces on the RS880D. Interface names in blue are hyperlinks to the corresponding sections in this chapter.

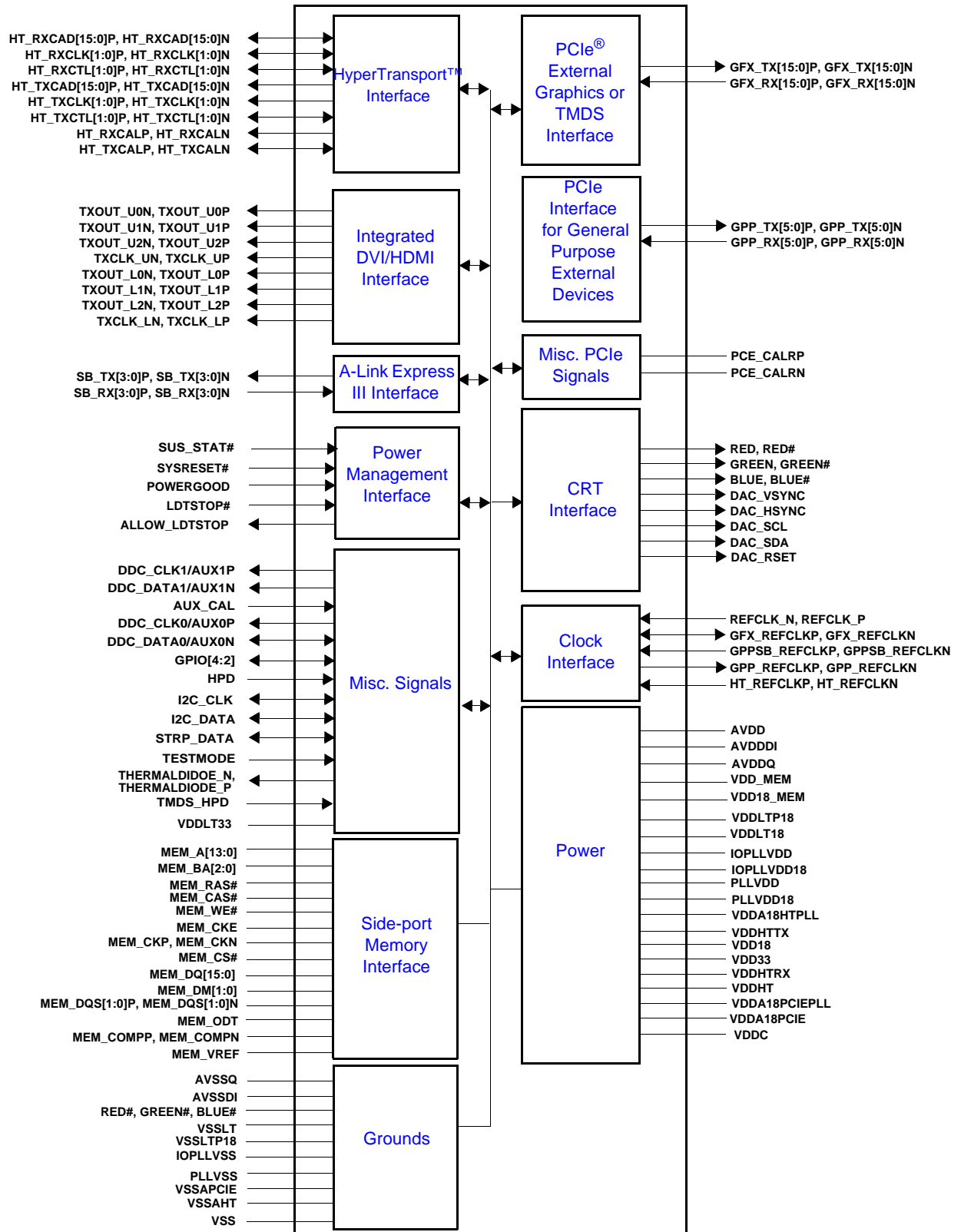

Figure 3-3 RS880D Interface Block Diagram

### 3.3 CPU HyperTransport™ Interface

Table 3-1 CPU HyperTransport™ Interface

Pin Name	Type	Power Domain	Ground Domain	Functional Description
HT_RXCAD[15:0]P, HT_RXCAD[15:0]N	I	VDDHTRX	VSS	Receiver Command, Address, and Data Differential Pairs
HT_RXCLK[1:0]P, HT_RXCLK[1:0]N	I	VDDHTRX	VSS	Receiver Clock Signal Differential Pairs. Forwarded clock signal. Each byte of RXCAD uses a different clock signal. Data is transferred on each clock edge.
HT_RXCTL[1:0]P, HT_RXCTL[1:0]N	I	VDDHTRX	VSS	Receiver Control Differential Pairs. For distinguishing control packets from data packets.
HT_TXCAD[15:0]P, HT_TXCAD[15:0]N	O	VDDHTTX	VSS	Transmitter Command, Address, and Data Differential Pairs
HT_TXCLK[1:0]P, HT_TXCLK[1:0]N	O	VDDHTTX	VSS	Transmitter Clock Signal Differential Pairs. Each byte of TXCAD uses a different clock signal. Data is transferred on each clock edge.
HT_TXCTL[1:0]P, HT_TXCTL[1:0]N	O	VDDHTTX	VSS	Transmitter Control Differential Pairs. Forwarded clock signal. For distinguishing control packets from data packets.
HT_RXCALN	Other	VDDHTRX	VSS	Receiver Calibration Resistor to VDD_HT power rail.
HT_RXCALP	Other	VDDHTRX	VSS	Receiver Calibration Resistor to Ground
HT_TXCALP	Other	VDDHTTX	VSS	Transmitter Calibration Resistor to HTTX_CALN
HT_TXCALN	Other	VDDHTTX	VSS	Transmitter Calibration Resistor to HTTX_CALP

### 3.4 Side-port Memory Interface

Table 3-2 Side-Port Memory Interface

Pin Name	Type	Power Domain	Ground Domain	Integrated Termination	Functional Description
MEM_A[13:0]	O	VDD_MEM	VSS	None	Memory Address Bus. Provides the multiplexed row and column addresses to the memory.
MEM_BA[2:0]	O	VDD_MEM	VSS	None	Memory Bank Address
MEM_RAS#	O	VDD_MEM	VSS	None	Row Address Strobe
MEM_CAS#	O	VDD_MEM	VSS	None	Column Address Strobe
MEM_WE#	O	VDD_MEM	VSS	None	Write Enable Strobe
MEM_CKE	O	VDD_MEM	VSS	None	Clock Enable
MEM_CKP, MEM_CKN	O	VDD_MEM	VSS	None	Memory Differential Clock
	O	VDD_MEM	VSS	None	
MEM_CS#	O	VDD_MEM	VSS	None	Chip Select
MEM_ODT	O	VDD_MEM	VSS	None	On-die Termination
MEM_DQ[15:0]	I/O	VDD_MEM	VSS	None	Memory Data Bus. Supports SSTL2 and SSTL3.
MEM_DM[1:0]	I/O	VDD_MEM	VSS	None	Data masks for each byte during memory write cycles
MEM_DQS[1:0]P, MEM_DQS[1:0]N	I/O	VDD_MEM	VSS	None	Memory Data Strobes. These are bi-directional data strobes for latching read/write data.
	I/O	VDD_MEM	VSS	None	
MEM_COMPP, MEM_COMPN	Other	VDD_MEM	VSS	None	Memory interface compensation pins for N and P channel devices. Connect through resistors to VDD_MEM and ground respectively (refer to the reference schematics for the proper resistor values).
MEM_VREF	Other	–	VSS	None	Reference voltage. It supplies the threshold value for distinguishing between “1” and “0” on a memory signal. Typical value is 0.5*VDD_MEM.

## 3.5 PCI Express® Interfaces

### 3.5.1 1 x 16 Lane Interface for External Graphics

**Table 3-3 1 x 16 or 2 x 8 Lane PCI Express® Interface for External Graphics**

Pin Name	Type	Power Domain	Ground Domain	Integrated Termination	Functional Description
GFX_TX[15:0]P, GFX_TX[15:0]N	O	VDDPCIE	VSSAPCIE	50Ω between complements	Transmit Data Differential Pairs. Connect to external connector[s] for external graphics card[s] on the motherboard (if implemented).
GFX_RX[15:0]P, GFX_RX[15:0]N	I	VDDPCIE	VSSAPCIE	50Ω between complements	Receive Data Differential Pairs. Connect to external connector[s] for external graphics card[s] on the motherboard (if implemented).

### 3.5.2 A-Link Express III Interface for Southbridge

**Note:** The widths of the A-Link Express III interface and the general purpose links for external devices are configured through the programmable strap GPPSB\_LINK\_CONFIG, which is programmed through RS880D's registers. See the *RS880 ASIC Family Register Reference Guide*, order# 46142, and the *RS880 ASIC Family Register Programming Requirements*, order# 46141, for details.

**Table 3-4 1 x 4 Lane A-Link Express III Interface for Southbridge**

Pin Name	Type	Power Domain	Ground Domain	Integrated Termination	Functional Description
SB_TX[3:0]P, SB_TX[3:0]N	O	VDDPCIE	VSSAPCIE	50Ω between complements	Transmit Data Differential Pairs. Connect to the corresponding Receive Data Differential pairs on the Southbridge.
SB_RX[3:0]P, SB_RX[3:0]N	I	VDDPCIE	VSSAPCIE	50Ω between complements	Receive Data Differential Pairs. Connect to the corresponding Transmit Data Differential pairs on the Southbridge.

### 3.5.3 6 x 1 Lane Interface for General Purpose External Devices

**Note:** The widths of the A-Link Express III interface and the general purpose links for external devices are configured through the programmable strap GPPSB\_LINK\_CONFIG, which is programmed through RS880D's registers. See the *RS880 ASIC Family Register Reference Guide*, order# 46142, and the *RS880 ASIC Family Register Programming Requirements*, order# 46141, for details.

**Table 3-5 6 x 1 Lane PCI Express® Interface for General Purpose External Devices**

Pin Name	Type	Power Domain	Ground Domain	Integrated Termination	Functional Description
GPP_TX[5:0]P, GPP_TX[5:0]N	O	VDDPCIE	VSSAPCIE	50Ω between complements	Transmit Data Differential Pairs. Connect to external connectors on the motherboard for add-in card or ExpressCard support.
GPP_RX[5:0]P, GPP_RX[5:0]N	I	VDDPCIE	VSSAPCIE	50Ω between complements	Receive Data Differential Pairs. Connect to external connectors on the motherboard for add-in card or ExpressCard support.

### 3.5.4 Miscellaneous PCI Express® Signals

**Table 3-6 PCI Express® Interface for Miscellaneous PCI Express® Signals**

Pin Name	Type	Power Domain	Ground Domain	Functional Description
PCE_CALRN	Other	VDDPCIE	VSSAPCIE	RX Impedance Calibration. Connect to VDDPCIE on the motherboard with an external resistor of an appropriate value.
PCE_CALRP	Other	VDDPCIE	VSSAPCIE	TX Impedance Calibration. Connect to GND on the motherboard with an external resistor of an appropriate value.

### 3.6 Clock Interface

Table 3-7 Clock Interface

Pin Name	Type	Power Domain	Ground Domain	Integrated Termination	Functional Description
HT_REFCLKP, HT_REFCLKN	I	VDDA18H TPLL	VSSAHT	–	HyperTransport™ 100MHz reference clock differential pair <b>External clock mode:</b> Input from external clock source, as a reference clock for the HyperTransport interface. <b>Internal clock mode*:</b> Input from the SB8xx Southbridge, as a reference clock for the HyperTransport interface.
GFX_REFCLKP, GFX_REFCLKN	I/O	VDDPCIE	VSSAPCIE	50Ω between complements	Clock Differential Pair for external graphics. <b>External clock mode:</b> Input from the external clock generator, as a reference clock for external graphics. <b>Internal clock mode*:</b> Not used. Pull down following instructions in the <i>RS880-Series IGP Motherboard Schematic Review Checklist</i> .
GPPSB_REFCLKP, GPPSB_REFCLKN	I	VDDPCIE	VSSAPCIE	50Ω between complements	Clock Differential Pair for Southbridge and general purpose PCIe® devices. <b>External clock mode:</b> Input from the external clock generator, as a reference clock for A-Link Express III and general purpose PCIe. <b>Internal clock mode*:</b> Input from the SB8xx Southbridge, as a reference clock for A-Link III and general purpose PCIe.
GPP_REFCLKP, GPP_REFCLKN	O	VDDPCIE	VSSAPCIE	50Ω between complements	Clock Differential Pair for general purpose PCIe devices. <b>External clock mode:</b> Not used. Can be left unconnected, or connected to the external clock generator for maintaining system compatibility with the RX881. <b>Internal clock mode*:</b> Output to a GPP device slot as a GPP clock.
REFCLK_P, REFCLK_N	I	VDD33	VSS	–	Reference clock input for the RS880D's display engine. <b>External clock mode:</b> REFCLK_P is a single-ended, 14.31818MHz input from the external clock generator; input swing should be 1.1V. Connect REFCLK_N to VREF (0.55V) on the motherboard. <b>Internal clock mode*:</b> Differential clock input from the SB8xx Southbridge.

\*Note: Internal clock mode is only available when using an SB8xx Southbridge. Use of the internal clock generator function is subject to characterization with actual RS880D and SB8xx devices

### 3.7 CRT Interface

Table 3-8 CRT Interface

Pin Name	Type	Power Domain	Ground Domain	Integrated Termination	Functional Description
RED	A-O	AVDD	–	–	Red for CRT monitor output
GREEN	A-O	AVDD	–	–	Green for CRT monitor output
BLUE	A-O	AVDD	–	–	Blue for CRT monitor output
DAC_HSYNC	A-O	VDD33	VSS	50kΩ programmable; PU/PD/none	Display Horizontal Sync
DAC_VSYNC	A-O	VDD33	VSS	50kΩ programmable; PU/PD/none	Display Vertical Sync
DAC_RSET	Other	N/A	AVSSQ	–	DAC internal reference to set full scale DAC current through 1% resistor to AVSSQ

Table 3-8 CRT Interface (Continued)

Pin Name	Type	Power Domain	Ground Domain	Integrated Termination	Functional Description
DAC_SDA	I/O	VDD33	VSS	50k $\Omega$ programmable: PU/PD/none	I2C data for display (to video monitor). The signal is 5V-tolerant.
DAC_SCL	I/O	VDD33	VSS	50k $\Omega$ programmable: PU/PD/none	I2C clock for display (to video monitor). The signal is 5V-tolerant.

### 3.8 Integrated DVI/HDMI™ Interface

Table 3-9 Integrated DVI/HDMI™ Interface

Pin Name	DVI/HDMI™ Functional Name	Type	Power Domain	Ground Domain	Integrated Termination	Functional Description
TXOUT_L0N	TX0M	O	VDDL18	VSSLT	None	DVI/HDMI™ data channel 0 (-)
TXOUT_L0P	TX0P	O	VDDL18	VSSLT	None	DVI/HDMI data channel 0 (+)
TXOUT_L1N	TX1M	O	VDDL18	VSSLT	None	DVI/HDMI data channel 1 (-)
TXOUT_L1P	TX1P	O	VDDL18	VSSLT	None	DVI/HDMI data channel 1 (+)
TXOUT_L2N	TX2M	O	VDDL18	VSSLT	None	DVI/HDMI data channel 2 (-)
TXOUT_L2P	TX2P	O	VDDL18	VSSLT	None	DVI/HDMI data channel 2 (+)
TXOUT_L3N	TX3M	O	VDDL18	VSSLT	None	DVI data channel 3 (-). The channel is only used in DVI dual-link mode and is not used for HDMI support.
TXOUT_L3P	TX3P	O	VDDL18	VSSLT	None	DVI data channel 3 (+). The channel is only used in DVI dual-link mode and is not used for HDMI support.
TXOUT_U0N	TX4M	O	VDDL18	VSSLT	None	DVI data channel 4 (-). The channel is only used in DVI dual-link mode and is not used for HDMI support.
TXOUT_U0P	TX4P	O	VDDL18	VSSLT	None	DVI data channel 4 (+). The channel is only used in DVI dual-link mode and is not used for HDMI support.
TXOUT_U1N	TX5M	O	VDDL18	VSSLT	None	DVI data channel 5 (-). The channel is only used in DVI dual-link mode and is not used for HDMI support.
TXOUT_U1P	TX5P	O	VDDL18	VSSLT	None	DVI data channel 5 (+). The channel is only used in DVI dual-link mode and is not used for HDMI support.
TXOUT_U2N	–	O	VDDL18	VSSLT	None	Unused
TXOUT_U2P	–	O	VDDL18	VSSLT	None	Unused
TXOUT_U3N	–	O	VDDL18	VSSLT	None	Unused
TXOUT_U3P	–	O	VDDL18	VSSLT	None	Unused
TXCLK_LN	TXCM	O	VDDL18	VSSLT	None	DVI/HDMI clock channel (-)
TXCLK_LP	TXCP	O	VDDL18	VSSLT	None	DVI/HDMI clock channel (+)
TXCLK_UN	–	O	VDDL18	VSSLT	None	Unused
TXCLK_UP	–	O	VDDL18	VSSLT	None	Unused

### 3.9 TMDS Interface Multiplexed on the PCI Express® Graphics Lanes

The RS880D supports a dual-link TMDS interface, enabling DVI/HDMI, which is multiplexed on the PCIe® external graphics lanes.

HDMI is enabled only through the single-link mode. [Table 3-10](#) to [Table 3-12](#) show the multiplexing relationships between the PCIe external graphics signals and the TMDS signals for different configurations. [Table 3-13](#) lists the miscellaneous TMDS signals that are not multiplexed on the PCIe graphics interface.

**Table 3-10 TMDS Interface Multiplexed on the PCI Express® Graphics Interface (Dual-Link DVI)**

Pin Name	Ball Reference	TMDS Function
GFX_TX0P	A5	TX2P - 1st Link Red+
GFX_TX0N	B5	TX2M - 1st Link Red-
GFX_TX1P	A4	TX1P - 1st Link Green+
GFX_TX1N	B4	TX1M - 1st Link Green-
GFX_TX2P	C3	TX0P - 1st Link Blue+
GFX_TX2N	B2	TX0M- 1st Link Blue -
GFX_TX3P	D1	TXCP - Clock+
GFX_TX3N	D2	TXCM - Clock-
GFX_TX4P	E2	TX5P- 2nd Link Red+
GFX_TX4N	E1	TX5M - 2nd Link Red-
GFX_TX5P	F4	TX4P- 2nd Link Green+
GFX_TX5N	F3	TX4M - 2nd Link Green-
GFX_TX6P	F1	TX3P - 2nd Link Blue+
GFX_TX6N	F2	TX3M - 2nd Link Blue-

**Table 3-11 TMDS Interface Multiplexed on the PCI Express® Graphics Interface (HDMI™ on Lane 0-3)**

Pin Name	Ball Reference	TMDS Function
GFX_TX0P	A5	TX2P - Red+
GFX_TX0N	B5	TX2M - Red-
GFX_TX1P	A4	TX1P - Green+
GFX_TX1N	B4	TX1M - Green-
GFX_TX2P	C3	TX0P - Blue+
GFX_TX2N	B2	TX0M- Blue -
GFX_TX3P	D1	TXCP - Clock+
GFX_TX3N	D2	TXCM - Clock-

**Table 3-12 TMDS Interface Multiplexed on the PCI Express® Graphics Interface (HDMI™ on Lane 4-7)**

Pin Name	Ball Reference	TMDS Function
GFX_TX4P	E2	TX2P - Red+
GFX_TX4N	E1	TX2M - Red-
GFX_TX5P	F4	TX1P - Green+
GFX_TX5N	F3	TX1M - Green-
GFX_TX6P	F1	TX0P - Blue+
GFX_TX6N	F2	TX0M- Blue -

Table 3-12 TMDS Interface Multiplexed on the PCI Express® Graphics Interface (HDMI™ on Lane 4-7) (Continued)

Pin Name	Ball Reference	TMDS Function
GFX_TX7P	H4	TXCP - Clock+
GFX_TX7N	H3	TXCM - Clock-

Table 3-13 Miscellaneous TMDS Interface Signals

Pin Name	Ball Reference	TMDS Function
DDC_CLK0/AUX0P	A8	DDC Clock 0 for display connected onto lane 0 to 3 (or 0 to 7 for dual-link DVI) of the PCIe® external graphics interface.* For detailed pin information, <i>see Table 3-17, “Miscellaneous Pins”</i> .
DDC_DATA0/AUX0N	B8	DDC Data Channel 0 for display connected onto lane 0 to 3 (or 0 to 7 for dual-link DVI) on the PCIe external graphics interface.* For detailed pin information, <i>see Table 3-17, “Miscellaneous Pins”</i> .
DDC_CLK1/AUX1P	B7	DDC Clock 1 for display connected onto lane 4 to 7 of the PCIe external graphics interface.* For detailed pin information, <i>see Table 3-17, “Miscellaneous Pins”</i> .
DDC_DATA1/AUX1N	A7	DDC Data Channel 1 for display connected onto lane 4 to 7 on the PCIe external graphics interface.* For detailed pin information, <i>see Table 3-17, “Miscellaneous Pins”</i> .

\*Note: Typical arrangements shown here. BIOS can select which DDC clock/data pair is to be used for each display.

### 3.10 DisplayPort™ Interface

The RS880D supports a maximum two DisplayPort™ (DP) channels through signals multiplexed on the PCIe graphics interface. Different implementations are possible, depending on the system configuration. *Table 3-10* shows only one possibility, which uses the lower eight lanes of the interface for a dual-link DP output. For more explanations, please refer to *RS880 DisplayPort Implementation Details*. *Table 3-15* lists the miscellaneous DP signals that are not multiplexed on the PCIe graphics interface.

Table 3-14 DisplayPort™ Interface Multiplexed on the PCI Express® Graphics Interface

Pin Name	Ball Reference	DisplayPort™ Function
GFX_TX0P, GFX_TX0N	A5/B5	Main Link Channel Pair 0 on the first DP connector
GFX_TX1P, GFX_TX1N	A4/B4	Main Link Channel Pair 1 on the first DP connector
GFX_TX2P, GFX_TX2N	C3/B2	Main Link Channel Pair 2 on the first DP connector
GFX_TX3P, GFX_TX3N	D1/D2	Main Link Channel Pair 3 on the first DP connector
DDC_CLK0/AUX0P, DDC_DATA0/AUX0N	A8/B8	Auxiliary Channel Pair 0 on the first DP connector
GFX_TX4P, GFX_TX4N	E2/E1	Main Link Channel Pair 0 on the second DP connector
GFX_TX5P, GFX_TX5N	F4/F3	Main Link Channel Pair 1 on the second DP connector
GFX_TX6P, GFX_TX6N	F1/F2	Main Link Channel Pair 2 on the second DP connector
GFX_TX7P, GFX_TX7N	H4/H3	Main Link Channel Pair 3 on the second DP connector
AUX_CAL	C8	Calibration for auxiliary pads.

Table 3-15 Miscellaneous DisplayPort™ Signals

Pin Name	Ball Reference	Display Port™ Function
DDC_CLK0/AUX0P, DDC_DATA0/AUX0N	A8/B8	Auxiliary Channel Pair 0 on the first DP connector. For detailed pin information, <i>see Table 3-17, “Miscellaneous Pins”</i> .
DDC_CLK1/AUX1P, DDC_DATA1/AUX1N	B7/A7	Auxiliary Channel Pair 1 on the second DP connector. For detailed pin information, <i>see Table 3-17, “Miscellaneous Pins”</i> .
HPD	D10	Hot plug detect for DisplayPort. Can also be used as GPIO. For detailed pin information, <i>see Table 3-17, “Miscellaneous Pins”</i> .

### 3.11 Power Management Pins

Table 3-16 Power Management Pins

Pin Name	Type	Power Domain	Ground Domain	Functional Description
LDTSTOP#	I	VDD33	VSS	HyperTransport™ Stop. Used for systems requiring power management. It is a single-ended signal for input from the Southbridge to enable and disable the HyperTransport link during system state transitions. <b>Note:</b> For platforms supporting DDR2 system memory, 1.8V signalling can be used on the signal. For platforms supporting DDR3 system memory, follow recommendations in the <i>RS880-Series IGP Motherboard Schematic Review Checklist</i> .
ALLOW_LDTSTOP	OD	VDD33	VSS	Allow LDTSTOP. The signal is used for controlling LDTSTOP assertions. It is an output to the SB. 1 = LDTSTOP# can be asserted 0 = LDTSTOP# has to be de-asserted <b>Note:</b> For platforms supporting DDR2 system memory, 1.8V signalling can be used on the signal. For platforms supporting DDR3 system memory, follow recommendations in the <i>RS880-Series IGP Motherboard Schematic Review Checklist</i> .
SYSRESET#	I	VDD33	VSS	Global Hardware Reset. This signal comes from the Southbridge.
SUS_STAT#	I	VDD33	VSS	Suspend Status. SUS_STAT# from the Southbridge is connected to the pin to gate the sideport memory I/Os while power is ramping up and the POWERGOOD signal to the RS880D is still low.
POWERGOOD	I	VDD18	VSS	Input from the motherboard signifying that the power to the RS880D is up and ready. Signal High means all power planes are valid. It is not observed internally until it has been high for more than six consecutive REFCLK cycles. The rising edge of this signal is deglitched.

### 3.12 Miscellaneous Pins

Table 3-17 Miscellaneous Pins

Pin Name	Type	Power Domain	Ground Domain	Integrated Termination	Functional Description
AUX_CAL	I	VDD33	VSS	50kΩ programmable: PU/PD/non	Calibration for auxiliary pads.
DDC_CLK0/AUX0P	I/O	VDD33	VSS	50kΩ programmable: PU/PD/none	DDC Clock 0 for displays, or AUX0P of the auxiliary pair for the DisplayPort connected onto lane 0 to 3 of the PCIe® external graphics interface. Can also be used as a GPIO.
DDC_DATA0/AUX0N	I/O	VDD33	VSS	50kΩ programmable: PU/PD/none	DDC Data Channel 0 for displays, or AUX0N of the auxiliary pair for the DisplayPort connected onto lane 0 to 3 on the PCIe external graphics interface. Can also be used as a GPIO.
DDC_CLK1/AUX1P	I/O	VDD33	VSS	50kΩ programmable: PU/PD/none	DDC Clock 1 for displays, or AUX1P of the auxiliary pair for the DisplayPort connected onto lane 4 to 7 of the PCIe external graphics interface. Can also be used as a GPIO.

Table 3-17 Miscellaneous Pins (Continued)

Pin Name	Type	Power Domain	Ground Domain	Integrated Termination	Functional Description
DDC_DATA1/AUX1N	I/O	VDD33	VSS	50k $\Omega$ programmable: PU/PD/none	DDC Data Channel 1 for displays, or AUX1N of the auxiliary pair for the DisplayPort connected onto lane 4 to 7 on the PCIe external graphics interface. Can also be used as a GPIO.
GPIO[4:2]	I/O	VDDR3	VSS	50k $\Omega$ programmable: PU/PD/none	General Purpose I/O. These pins can also be used as outputs to the voltage regulator for pulse-width modulation of various voltages on the motherboard. If not used for pulse-width-modulation, GPIO3 can also be used as a "hot plug" panel detection input pin that monitors if the voltage is greater than 2.0V on the hot-plugging line from a digital display.
HPD	I	VDD33	VSS	50k $\Omega$ programmable: PU/PD/none	Hot plug detect for DisplayPort. Can also be used as GPIO.
I2C_CLK	I/O	VDD33	VSS	50k $\Omega$ programmable: PU/PD/none	I <sup>2</sup> C interface clock signal. It can also be used as GPIO. The signal is 5V-tolerant.
I2C_DATA	I/O	VDD33	VSS	50k $\Omega$ programmable: PU/PD/none	I <sup>2</sup> C interface data signal. It can also be used as GPIO. The signal is 5V-tolerant.
NC	–	–	–	–	No connect. These pins should be left unconnected to anything.
STRP_DATA	I/O	VDD33	VSS	50k $\Omega$ programmable: PU/PD/none	I <sup>2</sup> C interface data signal for external EEPROM based strap loading. Can also be used as GPIO, or as output to the voltage regulator for pulse-width modulation of RS880D's core voltage.
TESTMODE	I	VDD33	VSS	–	When High, puts the RS880D in test mode and disables the RS880D from operating normally.
THERMALDIODE_P, THERMALDIODE_N	A-O	–	–	–	Diode connections to external SMBus microcontroller for monitoring IC thermal characteristics.
TMDS_HPD	I/O	VDD33	VSS	50k $\Omega$ programmable: PU/PD/none	TMDS Hot Plug Detect. It monitors the hot-plug line for panel detection. It is a 3.3V CMOS compatible input. When not used for hot plug detection, it can also be used as output to the voltage regulator for pulse-width modulation of various voltages on the motherboard.
VDDL33	Other	–	–	–	These balls are only for maintaining pin-compatibility with earlier generations of AMD IGP's or chipsets. They can either be connected to a 3.3V rail or left unconnected on RS880D systems.

### 3.13 Power Pins

Table 3-18 Power Pins

Pin Name	Voltage	Pin Count	Ball Reference	Pin Description
AVDD	3.3V	2	E12, F12	Dedicated power for the DAC. Effort should be made at the board level to provide as clean a power as possible to this pin to avoid noise injection, which can affect display quality. Adequate decoupling should be provided between this pin and AVSS.
AVDDDI	1.8V	1	F14	Dedicated digital power for the DAC
AVDDQ	1.8V	1	H15	DAC Bandgap Reference Voltage
IOPLLVD	1.1V	1	AE24	1.1V power for memory I/O PLLs
IOPLLVD18	1.8V	1	AE23	1.8V power for memory I/O PLLs
PLLVDD	1.1V	1	A12	1.1V Power for system PLLs
PLLVDD18	1.8V	1	D14	1.8V power for system PLLs
VDD_MEM	1.5/1.8V	6	AA11, AB10, AC10, AD10, AE10, Y11	Isolated power for side-port memory interface.
VDD18_MEM	1.8V	2	AD11, AE11	1.8V power for side-port memory interface

Table 3-18 Power Pins (Continued)

Pin Name	Voltage	Pin Count	Ball Reference	Pin Description
VDDA18HTPLL	1.8V	1	H17	I/O power for HyperTransport™ PLL
VDDA18PCIE	1.8V	15	AA9, AB9, AD9, AE9, H9, J10, K10, L10, M10, P10, R10, T10, U10, W9, Y9	1.8V I/O power for PCIe® graphics, SB, and GPP interfaces
VDDA18PCIEPLL	1.8V	2	D7, E7	1.8V I/O power for PCIe PLLs
VDDC	1.3V	22	J11, J14, J16, K12, K15, L11, L14, M12, M13, M15, N12, N14, P11, P13, P14, R12, R15, T11, T14, T15, U12, U16	Core power
VDD18	1.8V	2	F9, G9	1.8V I/O transform power
VDD33	3.3V	2	H11, H12	3.3V I/O power
VDDHT	1.1V	7	J17, K16, L16, M16, P16, R16, T16	Digital I/O power for HyperTransport interface
VDDHTRX	1.1V	7	A23, B23, D22, E21, F20, G19, H18	I/O power for HyperTransport receive interface
VDDHTTX	1.2V	13	AA21, AB22, AC23, AD24, AE25, M17, P17, R17, T17, U17, V18, W19, Y20	I/O power for HyperTransport transmit interface
VDDL18	1.8V	2	A15, B15	1.8V I/O power for the integrated DVI/HDMI™ interface
VDDLTP18	1.8V	1	A13	Power for integrated DVI/HDMI PLL macro.
VDDPCIE	1.1V	17	A6, B6, C6, D6, E6, F6, G7, H8, J9, K9, L9, M9, P9, R9, T9, U9, V9	Main I/O power for PCIe graphics, SB, and GPP interfaces
Total Power Pin Count		107		

### 3.14 Ground Pins

Table 3-19 Ground Pins

Pin Name	Pin Count	Ball Reference	Comments
AVSSDI	1	G15	Dedicated digital ground for the DAC (1.8V)
AVSSQ	1	H14	Dedicated ground for the Band Gap Reference. Effort should be made at the board level to provide as clean a ground as possible to this pin to avoid noise injection, which can affect display quality. Adequate decoupling should be provided between this pin and AVDD.
PLLVSS	1	B12	Ground pin for graphics core PLL
RED#, GREEN#, BLUE#	3	G17, F18, F19	Grounds for the DAC. These pins must be connected directly to ground.
VSS	34	AA14, AB11, AB15, AB17, AB19, AB21, AC12, AE14, AE20, D11, E14, E15, G8, J12, J15, K11, K14, L12, L15, M11, M14, N13, P12, P15, R11, R14, T12, U11, U14, U15, V12, W11, W15, Y18	Common Ground

Table 3-19 Ground Pins (Continued)

Pin Name	Pin Count	Ball Reference	Comments
VSSAHT	27	A25, AD25, D23, E22, G22, G24, G25, H19, H20, J22, L17, L22, L24, L25, M20, N22, P20, R19, R22, R24, R25, U22, V19, W22, W24, W25, Y21	Ground pin for HyperTransport interface PLL
VSSAPCIE	40	A2, AA4, AB1, AB2, AB5, AB7, AC3, AC4, AE1, AE4, B1, D3, D5, E4, G1, G2, G4, H7, J4, L1, L2, L4, L7, M6, N4, P6, R1, R2, R4, R7, U4, V6, V7, V8, W1, W2, W4, W7, W8, Y6	Ground for PCI Express® Interface
VSSLT	7	C14, C16, C18, C20, C22, D15, E20	Integrated DVI/HDMI™
VSSLTP18	1	B13	Ground for Integrated DVI/HDMI PLL macro
Total Ground Pin Count	113		

### 3.15 Strapping Options

The RS880D provides strapping options to define specific operating parameters. The strap values are latched into internal registers after the assertion of the POWERGOOD signal to the RS880D. [Table 3-20, “Strap Definitions for the RS880D,”](#) shows the definitions of all the strap functions. These straps are set by one of the following four methods:

- Attaching pull-up resistors to specific strap pins listed in [Table 3-20](#) to set their values to “1”.
- Attaching pull-down resistors to specific strap pins listed in [Table 3-20](#) to set their values to “0”.
- Downloading the strap values from an I<sup>2</sup>C serial EEPROM (for debug purpose only; contact your AMD CSS representative for details).
- Setting through an external debug port, if implemented (contact your AMD CSS representative for details).

All of the straps listed in [Table 3-20](#) are defined active low. To select “1”, the strap pins must be pulled up to VDD33 through resistors. To select “0”, the strap pins must be pulled down to VSS through resistors. During reset, the strap pins are undriven, allowing the external pull-up or pull-down to pull a pin to “0” or “1.” The values on the strap pins are then latched into the device and used as operational parameters. However, for debug purposes, those latched values may be overridden through an external debug strap port or by a bit-stream downloaded from a serial EEPROM.

Table 3-20 Strap Definitions for the RS880D

Strap Function	Strap Pin	Description
STRAP_DEBUG_BUS_GPIO_ENABLE#	DAC_VSYNC	Enables debug bus access through memory I/O pads and GPIOs. 0: Enable 1: Disable (See debug bus specification documents for more details.)
SIDE_PORT_EN#	DAC_HSYNC	Indicates if memory side-port is available or not. 0: Available 1: Not available
LOAD_EEPROM_STRAPS#	SUS_STAT#	Selects loading of strap values from EEPROM. 0: I <sup>2</sup> C master can load strap values from EEPROM if connected, or use default values if EEPROM is not connected. Please refer to RS880D's reference schematics for system level implementation details. 1: Use default values

**Note:** On the RS880D, the widths of the A-Link Express III interface and the general purpose PCIe links are configured through the programmable strap GPPSB\_LINK\_CONFIG, which is programmed through RS880D's registers. See the *RS880 ASIC Family Register Reference Guide*, order# 46142, and the *RS880 ASIC Family Register Programming Requirements*, order# 46141, for details.

# Chapter 4

## Timing Specifications

### 4.1 HyperTransport™ Bus Timing

For HyperTransport™ bus timing information, please refer to CPU specifications.

### 4.2 HyperTransport™ Reference Clock Timing Parameters

**Table 4-1 Timing Requirements for HyperTransport™ Reference Clock (100MHz) Output by the Clock Generator**

Symbol	Parameter	Minimum	Maximum	Unit	Note
$\Delta V_{\text{CROSS}}$	Change in Crossing point voltage over all edges	-	140	mV	1
F	Frequency	99.9	100	MHz	2
ppm	Long Term Accuracy	-300	+300	Ppm	3
$S_{\text{FALL}}$	Output falling edge slew rate	-10	-0.5	V/ns	4, 5
$S_{\text{RISE}}$	Output rising edge slew rate	0.5	10	V/ns	4, 5
$T_{\text{jc max}}$	Jitter, cycle to cycle	-	150	ps	6
$T_{\text{j-accumulated}}$	Accumulated jitter over a 10 $\mu\text{s}$ period	-1	1	ns	7
$V_{\text{D(PK-PK)}}$	Peak to Peak Differential Voltage	400	2400	mV	8
$V_{\text{D}}$	Differential Voltage	200	1200	mV	9
$\Delta V_{\text{D}}$	Change in $V_{\text{DDC}}$ cycle to cycle	-75	75	mV	10
DC	Duty Cycle	45	55	%	11

**Notes:**

More details are available in *AMD HyperTransport 3.0 Reference Clock Specification* and *AMD Family 10h Processor Reference Clock Parameters*, order # 34864.

1 Single-ended measurement at crossing point. Value is maximum-minimum over all time. DC value of common mode is not important due to blocking cap.

2 Minimum frequency is a consequence of 0.5% down spread spectrum.

3 Measured with spread spectrum turned off.

4 Only simulated at the receive die pad. This parameter is intended to give guidance for simulation. It cannot be tested on a tester but is guaranteed by design.

5 Differential measurement through the range of  $\pm 100\text{mV}$ , differential signal must remain monotonic and within slew rate specification when crossing through this region.

6  $T_{\text{jc max}}$  is the maximum difference of  $t_{\text{CYCLE}}$  between any two adjacent cycles.

7 Accumulated  $T_{\text{jc}}$  over a 10 $\mu\text{s}$  time period, measured with J1T2 TIE at 50ps interval.

8  $V_{\text{D(PK-PK)}}$  is the overall magnitude of the differential signal.

9  $V_{\text{D(min)}}$  is the amplitude of the ring-back differential measurement, guaranteed by design that the ring-back will not cross 0V  $V_{\text{D}}$ .

$V_{\text{D(max)}}$  is the largest amplitude allowed.

10 The difference in magnitude of two adjacent  $V_{\text{DDC}}$  measurements.  $V_{\text{DDC}}$  is the stable post overshoot and ring-back part of the signal.

11 Defined as  $t_{\text{HIGH}}/t_{\text{CYCLE}}$ .

### 4.3 PCI Express® Differential Clock AC Specifications

Table 4-2 PCI Express® Differential Clock (GFX\_REFCLK, GPPSB\_REFCLK, 100MHz) AC Characteristics

Symbol	Description	Minimum	Maximum	Unit
Rising Edge Rate	Rising Edge Rate	0.6	4.0	V/ns
Falling Edge Rate	Falling Edge Rate	0.6	4.0	V/ns
T <sub>PERIOD AVG</sub>	Average Clock Period Aquaria	-300	+2800	ppm
T <sub>PERIOD ABS</sub>	Absolute Period (including jitter and spread spectrum modulation)	9.847	10.203	ns
T <sub>CCJITTER</sub>	Cycle to Cycle Jitter	-	150	Ps
Duty Cycle	Duty Cycle	40	60	%
Rise-Fall Matching	Rising edge rate (REFCLK+) to falling edge rate (REFCLK-) matching	-	20	%

### 4.4 Timing Requirements for REFCLK\_P Used as OSCIN (14.3181818MHz)

Table 4-3 Timing Requirements for REF\_CLKP Used as OSCIN (14.3181818MHz)

Symbol	Parameter	Min	Max	Unit	Note
TIP	REFCLK Period	69.82033	69.86224	ns	
TIH	REFCLK High Time	2.0	–	ns	
TIL	REFCLK Low Time	2.0	–	ns	
TIR	REFCLK Rise Time	–	1.5	ns	1
TIF	REFCLK Fall Time	–	1.5	ns	1
TIRR	REFCLK Rising Edge Rate	0.09	4.0	V/ns	
TIFR	REFCLK Falling Edge Rate	0.09	4.0	V/ns	
TIDC	Duty Cycle	45	55	%	2
TIJCC	REFCLK Cycle-to-Cycle Jitter Requirement	–	300	ps	3
TIJPP	REFCLK Peak-to-Peak Jitter Requirement	–	200	ps	2, 3
TIJLT	REFCLK Long Term Jitter Requirement (1µs after scope trigger)	–	500	ps	

**Notes:**

1. Measured from -150mV to + 150mV from VREF, which is 0.55V.
2. Measured at VREF, which is 0.55V.
3. Measured with spread spectrum disabled.

### 4.5 Side-port Memory Timing for DDR2 Mode

The RS880D's side-port memory DDR2 interface complies with all the timing requirements given in the JESD79-2B specification. Please refer to the JEDEC standard for any timing details.

#### 4.5.1 Read Cycle DQ/DQS Delay

During a memory read cycle, there is a DLL inside the RS880D that can delay each DQS signal with respect to its byte of the DQ valid window. This delay ensures adequate setup and hold time to capture the memory data. This DLL delay is programmable through the following registers:

MCA\_DLL\_SLAVE\_RD\_0. MCA\_DLL\_ADJ\_DQSR\_0 <NBMCIND : 0xE0[7:0]>

MCA\_DLL\_SLAVE\_RD\_1. MCA\_DLL\_ADJ\_DQSR\_1 <NBMCIND : 0xE1[7:0]>

The fraction of strobe delay, in terms of a memory clock period is  $(24 + \text{MCA\_DLL\_ADJ\_DQSR}) / 240$ . For example: if  $\text{MCA\_DLL\_ADJ\_DQSR}_1 = 36$ , then DQS1 is delayed by  $0.25 \times \text{memory\_clock\_period}$ . So, if the memory clock period is 5ns, then DQS1 is delayed internally by 1.25ns with respect to DQ[15:8].

## 4.5.2 Write Cycle DQ/DQS Delay

Similar to a read cycle, during memory write cycle there is a DLL inside the RS880D that can delay each DQS signal with respect to its byte of the DQ valid window. This delay ensures adequate setup and hold time for DQ and DQS to the memory. This DLL delay is programmable by the following registers in the same manner as with the read cycle:

`MCA_DLL_SLAVE_WR_0.MCA_DLL_ADJ_DQ_B0 <NBMCIND : 0xE8[7:0]>`

`MCA_DLL_SLAVE_WR_1.MCA_DLL_ADJ_DQ_B1 <NBMCIND : 0xE9[7:0]>`

Again, the fraction of strobe delay, in terms of a memory clock period is  $(24 + \text{MCA\_DLL\_ADJ\_DQSR}) / 240$ . For example: if `MCA_DLL_ADJ_DQ_B0 = 96`, then `DQS0` is delayed by  $0.5 \times \text{memory\_clock\_period}$ . So, if the memory clock period is 5ns, then `DQS0` is delayed internally by 2.5ns with respect to `DQ[7:0]`.

Depending on the board layout of DQS and DQ signals, it may be necessary to have different delays for each DQS signal. Layouts of the DQS and DQ signals should follow the rules given in the *AMD RS880-Series IGP Motherboard Design Guide*, order# 46103.

## 4.6 Power Rail Power-up Sequence

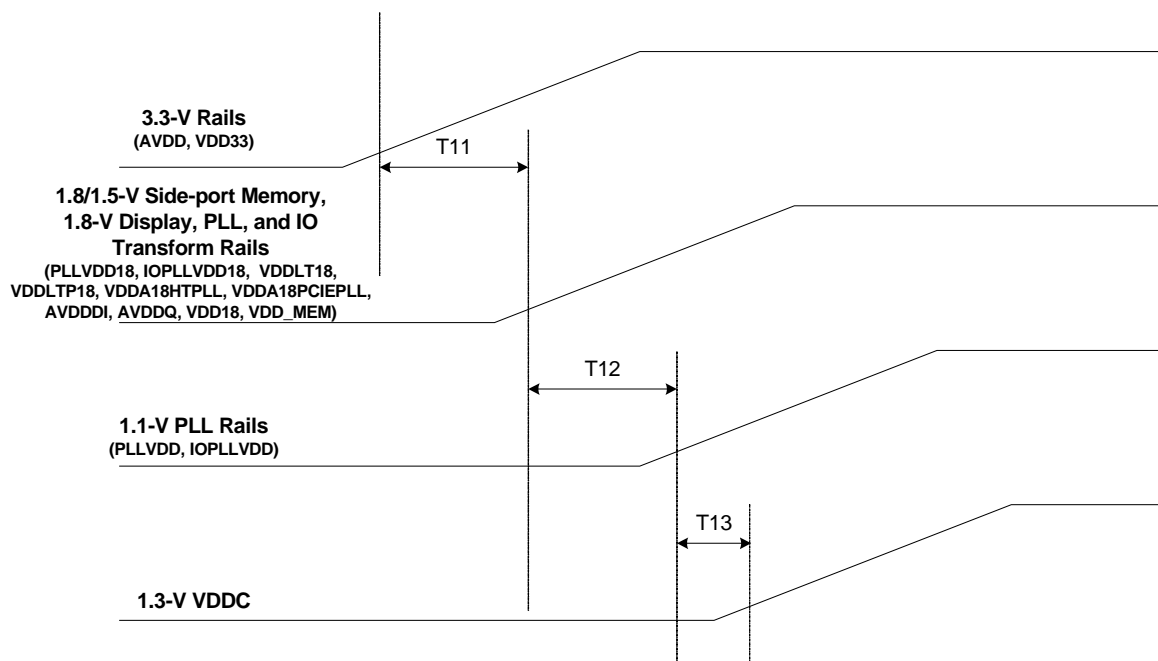

Note: There are no specific requirements for the following 1.1-V or 1.2-V rails: VDDHT, VDDHTRX, VDDHTTX, VDDPCIE

Table 4-4 RS880D Power Rail Power-up Sequence

Symbol	Parameter	Voltage Difference During Ramping	
		Minimum (V)	Maximum (V)
T11	3.3-V rails ramp high relative to 1.8/1.5-V Side-Port Memory, 1.8-V Display, PLL, and I/O Transform rails	0	2.1
T12	1.8/1.5-V Side-Port Memory, 1.8-V Display, PLL, and I/O Transform rails ramp high relative to 1.1-V PLL rails	0	No restrictions
T13	1.1-V PLL rails ramp high relative to VDDC (1.3V)	0	No restrictions

This page is left blank intentionally.

# Chapter 5

## Electrical Characteristics and Physical Data

### 5.1 Electrical Characteristics

#### 5.1.1 Maximum and Minimum Ratings

Table 5-1 Maximum and Minimum Ratings

Pin	Minimum	Typical	Maximum	Unit	Comments
AVDD	3.135	3.3	3.465	V	Dedicated power for the DAC
AVDDDI	1.71	1.8	1.89	V	Dedicated digital power for the DAC
IOPLLVD	1.045	1.1	1.155	V	1.1V power for memory I/O PLLs
IOPLLVD18	1.71	1.8	1.89	V	1.8V power for memory I/O PLLs
PLLVD	1.045	1.1	1.155	V	1.1V power for system PLLs
PLLVD18	1.71	1.8	1.89	V	1.8V power for system PLLs
VDD_MEM	1.425/1.71	1.5/1.8V	1.575/1.89	V	Isolated power for side-port memory interface
VDD18_MEM	1.71	1.8	1.89	V	1.8V power for side-port memory interface
VDDA18HTPLL	1.71	1.8	1.89	V	I/O power for HyperTransport™ PLL
VDDA18PCIE	1.71	1.8	1.89	V	1.8V I/O power for PCIe® graphics, SB, and GPP interfaces
VDDA18PCIEPLL	1.71	1.8	1.89	V	1.8V I/O power for PCIe PLLs
VDDC	1.235	1.3	1.365	V	Core power
VDD18	1.71	1.8	1.89	V	1.8V I/O transform power
VDD33	3.135	3.3	3.465	V	3.3V I/O power
VDDHT	1.045	1.1	1.155	V	I/O power for HyperTransport interface
VDDHTRX	1.045	1.1	1.155	V	I/O power for HyperTransport receive interface
VDDHTTX	1.14	1.2	1.26	V	I/O power for HyperTransport transmit interface
VDDL18	1.71	1.8	1.89	V	1.8V I/O power for the integrated DVI/HDMI™ interface
VDDLTP18	1.71	1.8	1.89	V	Power for integrated DVI/HDMI PLL macro
VDDPCIE	1.045	1.1	1.155	V	Main I/O power for PCIe graphics, SB, and GPP interfaces

**Note:** Numbers in this table are to be qualified.

5.1.2 DC Characteristics

Table 5-2 DC Characteristics for 3.3V TTL Signals

Pins	Symbol	Description	Minimum	Maximum	Unit
All pins belonging to the VDD33 domain (refer to pin description tables in this chapter).	VILdc	DC voltage at the pad that will produce a stable low input to the chip	–	0.7	V
	VIHdc	DC voltage at pad that will produce a stable high input to the chip	1.4	–	V
	VILac	AC input low voltage	–	0.15	V
	VIHac	AC input high voltage	2.5	–	V
	VOLdc	Output low voltage**	–	0.53	V
	VOHdc	Output high voltage**	2.46	–	V
	IOLdc	Output low current at V=0.1V**	2.8	–	mA
	IOHdc	Output high current at V=VDD33-0.1V**	2.6	–	mA

Note: \* Measured with edge rate of 1µs at PAD pin.

\*\* For detailed current/voltage characteristics, please refer to the IBIS model.

Table 5-3 DC Characteristics for DDC Signals (DDC Mode)

Pins	Symbol	Description	Minimum	Maximum	Unit	Note
DDC_DATA0/AUX0N DDC_CLK0/AUX0P DDC_DATA1/AUX1N DDC_CLK1/AUX1P	VILdc	DC voltage at the pad that will produce a stable low input to the chip	–	1.5	V	1
	VIHdc	DC voltage at pad that will produce a stable high input to the chip	3.0	–	V	1
	VOL	Output low voltage	–	86mV @ I=3mA, 230mV @ I=8mA	V	2, 3, 4
	VOH	Output high voltage	VDD5-0.25 (VDD5 is external 5V DDC pull-up supply)	–	V	2, 3, 4
	IOL	Output low current at V=0.1V	0.55	6.25	mA	2, 3, 4

Notes:

1. Measured with edge rate of 1µs at PAD pin.
2. For detailed current/voltage characteristics, please refer to the IBIS model.
3. Measurement taken with PMOS/NMOS strength set to default values, PVT=Nominal Case.
4. Interface circuit is open drain. Pulled high by external power.

Table 5-4 DC Characteristics for AUX Signals (AUX Mode)

Pins	Symbol	Description	Minimum	Maximum	Unit
DDC_DATA0/AUX0N DDC_CLK0/AUX0P DDC_DATA1/AUX1N DDC_CLK1/AUX1P	Vcm	Input/output common mode voltage	569	610	mV
	Vdiff	Pad differential output swing	525	622	mV

Note: The AUX signals comply with VESA's *DisplayPort Standard*; please refer to the document for other electrical characteristics of the signals.

Table 5-5 DC Characteristics for POWERGOOD

Symbol	Description	Minimum	Typical	Maximum
VIL	Input Low Voltage	0	0V	300mV
VIH	Input High Voltage	1.62V	1.8V	1.98V

**Table 5-6 DC Characteristics for HyperTransport™ and PCI-E Differential Clock (HT\_REFCLK, GFX\_REFCLK, GPPSB\_REFCLK, 100MHz)**

Symbol	Description	Minimum	Maximum	Unit
V <sub>IL</sub>	Differential Input Low Voltage	-	-150	mV
V <sub>IH</sub>	Differential Input High Voltage	+150	-	mV
V <sub>CROSS</sub>	Absolute Crossing Point Voltage	+250	+550	mV
V <sub>CROSS DELTA</sub>	Variation of V <sub>CROSS</sub> over all rising clock edges	-	+140	mV
V <sub>RB</sub>	Ring-back Voltage Margin	-100	+100	mV
V <sub>IMAX</sub>	Absolute Max Input Voltage	-	+1.15	V
V <sub>IMIN</sub>	Absolute Min Input Voltage	-	-0.15	V

**Table 5-7 DC Characteristics for REFCLK\_P as OSCIN Input (14.3181818MHz)**

Symbol	Description	Minimum	Maximum	Unit	Note
V <sub>IL</sub>	Single Input Low Voltage	-	0.40	V	1
V <sub>IH</sub>	Single Input High Voltage	0.70	-	V	2
V <sub>IMAX</sub>	Absolute Max Input Voltage	-	+1.15	V	
V <sub>IMIN</sub>	Absolute Min Input Voltage	-	-0.15	V	
Z <sub>C-DC</sub>	Clock source DC impedance	40	60	Ω	

**Notes:**

1. V<sub>ILmax</sub> = VREF - 0.15V, where VREF = 0.55V
2. V<sub>IHmin</sub> = VREF + 0.15V, where VREF = 0.55V

**Table 5-8 DC Characteristics for the Memory Interface when Supporting DDR2**

Symbol	Description	Minimum	Maximum	Comments
V <sub>IL(dc)</sub>	DC Input Low Voltage	-0.3V	VREF-0.15V	For DQ and DQS
V <sub>IH(dc)</sub>	DC Input High Voltage	VREF + 0.15V	VDDQ + 0.3V	For DQ and DQS. (VDDQ is I/O voltage of memory device.)
V <sub>IL(ac)</sub>	AC Input Low Voltage	-	VREF - 0.31V	For DQ and DQS
V <sub>IH(ac)</sub>	AC Input High Voltage	VREF + 0.31V	-	For DQ and DQS
V <sub>USH</sub>	Minimum Voltage Allowed for Undershoot	- 0.3V	-	For DQ and DQS
V <sub>OSSH</sub>	Maximum Voltage Allowed for Overshoot	-	VDDQ + 0.3V	For DQ and DQS. (VDDQ is I/O voltage of memory device.)
V <sub>OI</sub>	Output Low Voltage	0.186V	0.305V	I <sub>out</sub> = 16.5mA
V <sub>OH</sub>	Output High Voltage	1.7V	1.9V	I <sub>out</sub> = -16.5mA
VREF	DC Input Reference Voltage	0.882V	0.918V	
I <sub>LI</sub>	Input Leakage Current	10μA	15μA	
I <sub>LO</sub>	Tri-state Leakage Current	10μA	15μA	
I <sub>OL</sub>	Output Low Current	19mA	28mA	
I <sub>OH</sub>	Output High Current	-19mA	-29.5mA	
C <sub>IN</sub>	Input Capacitance	3pF	5pF	

**Table 5-9 DC Characteristics for the Memory Interface when Supporting DDR3**

Symbol	Description	Minimum	Maximum	Comments
V <sub>IL(dc)</sub>	DC Input Low Voltage	-0.3V	VREF - 0.1V	For DQ and DQS
V <sub>IH(dc)</sub>	DC Input High Voltage	VREF + 0.1V	VDDQ + 0.3V	For DQ and DQS. (VDDQ is IO voltage of memory device.)

Symbol	Description	Minimum	Maximum	Comments
VIL(ac)	AC Input Low Voltage	–	VREF - 0.15V	For DQ and DQS
VIH(ac)	AC Input High Voltage	VREF + 0.15V	–	For DQ and DQS
VUSH	Minimum Voltage Allowed for Undershoot	- 0.3V	–	For DQ and DQS
VOSH	Maximum Voltage Allowed for Overshoot	–	VDDQ + 0.3V	For DQ and DQS. (VDDQ is IO voltage of memory device.)
VOI	Output Low Voltage	0.186V	0.305V	I <sub>out</sub> = 16.5mA
VOH	Output High Voltage	1.4V	1.6V	I <sub>out</sub> = -16.5mA
VREF	DC Input Reference Voltage	0.735V	0.765V	
ILI	Input Leakage Current	10μA	15μA	
ILO	Tri-state Leakage Current	10μA	15μA	
IOL	Output Low Current	16.5mA	24.3mA	
IOH	Output High Current	-15.8mA	-24.6mA	
CIN	Input Capacitance	3pF	5pF	

Table 5-10 DC Characteristics for the Integrated DVI/HDMI™

Symbol	Parameter	Min	Typical	Max	Unit	Note
VH	Single-ended High Level Output Voltage	AVCC - 10	–	AVCC + 10	mV	1
VL	Single-ended Low Level Output Voltage	AVCC - 600	–	AVCC - 400	mV	1
VSW	Single-ended Output Swing	400	–	600	mV	
VOS	Differential Output Overshoot (Ringing)	–	–	15%*2VSW	–	
VUS	Differential Output Undershoot (Ringing)	–	–	25%*2VSW	–	
IDDLP	Average Supply Current at LPVDD	–	20.0	–	mA	2
IDDLV	Average Supply Current at LVDDR18 and LVDDR33	–	100.0	–	mA	2
IOL	Output Low Current	–	8	–	mA	
IOH	Output High Current	–	12	–	mA	
IPDLP	Power Down Current at LPVDD	–	10.0	–	μA	3
IPDLV	Power Down Current at LVDDR18 and LVDDR33	–	10.0	–	μA	3

**Notes:**

- 1 AVCC stands for the termination supply voltage of the receiver, which is 3.3V +/- 5%.
- 2 Measured under typical conditions, at minimum differential clock frequency and maximum DVI/HDMI™ PLL VOC frequency.
- 3 Measured under typical conditions, based on typical leakage values.
- 4 Figure 5-1 below illustrates some of the DC Characteristics of the DVI/HDMI interface.

Table 5-11 DC Characteristics for the TMDS Interface Multiplexed on the PCI Express® Gfx Lanes

Symbol	Parameter	Min	Typical	Max	Unit	Note
VH	Single-ended High Level Output Voltage	AVCC - 10	–	AVCC + 10	mV	1
VL	Single-ended Low Level Output Voltage	AVCC - 600	–	AVCC - 400	mV	1
VSW	Single-ended Output Swing	400	–	600	mV	
VOS	Differential Output Overshoot (Ringing)	–	–	15%*2VSW	–	
VUS	Differential Output Undershoot (Ringing)	–	–	25%*2VSW	–	

**Notes:**

- 1 AVCC stands for the termination supply voltage of the receiver, which is 3.3V +/- 5%.
- 2 Figure 5-1 below illustrates some of the DC Characteristics of the TMDS interface.

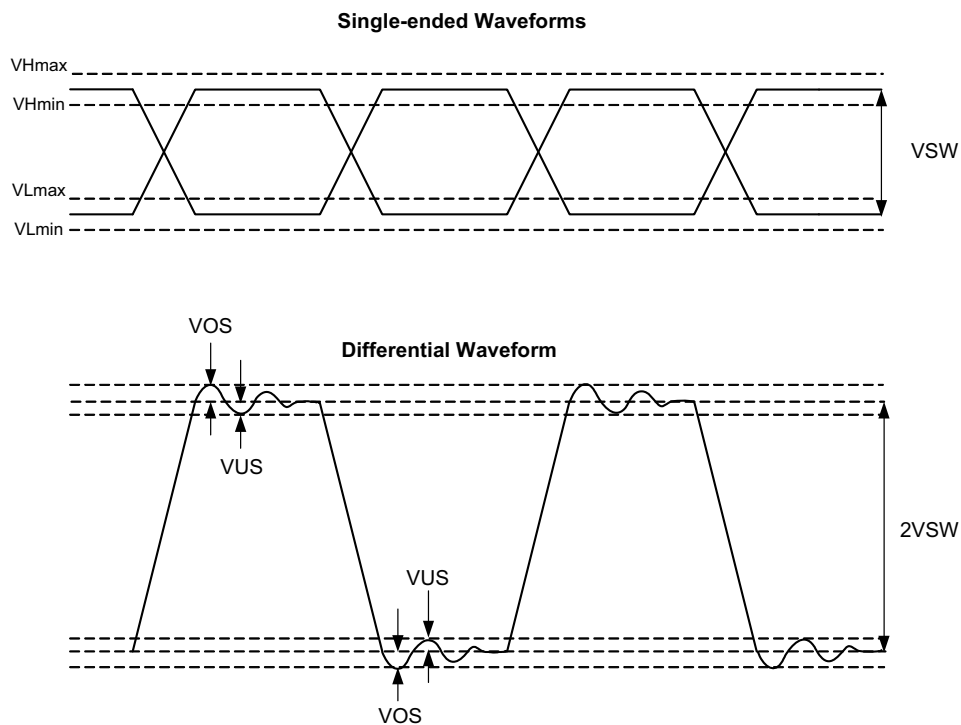

Figure 5-1 DC Characteristics of the Integrated DVI/HDMI™ and the TMDS Interfaces

Table 5-12 Electrical Specifications for the DisplayPort Interface

Symbol	Parameter	Min	Typ	Max	Unit	Notes
U <sub>I</sub> HIGH_RATE	Unit Interval for DP High Bit Rate (2.7 Gbps/lane)	-	370	-	ps	High limit = +300 ppm Low limit = -5300 ppm
U <sub>I</sub> LOW_RATE	Unit Interval for DP Reduced Bit Rate (1.62 Gbps/lane)	-	617	-	ps	High limit = +300 ppm Low limit = -5300 ppm
V <sub>TX-DIFFP_p</sub>	Differential Peak-to-Peak Output Voltage Level	0.34	-	0.92	V	-
V <sub>TX-PREEMPP-RATIO</sub>	Pre-emphasis Level	0	-	7.2	dB	-

## 5.2 RS880D Thermal Characteristics

This section describes some key thermal parameters of the RS880D. For a detailed discussion on these parameters and other thermal design descriptions including package level thermal data and analysis, please consult the *Thermal Design and Analysis Guidelines for the RS880 Product Family*, order# 46139.

### 5.2.1 RS880D Thermal Limits

**Table 5-13 RS880D Thermal Limits**

Parameter	Minimum	Nominal	Maximum	Unit	Note
Operating Case Temperature	0	—	95	°C	1
Absolute Rated Junction Temperature	—	—	115	°C	2
Storage Temperature	-40	—	60	°C	
Ambient Temperature	0	—	45	°C	3
Thermal Design Power	—	25	—	W	4

**Notes:**

1 - The maximum operating case temperature is the die geometric top-center temperature measured via a thermocouple based on the methodology given in the document *Thermal Design and Analysis Guidelines for the RS880 Product Family*, order# 46139 (Chapter 12). This is the temperature at which the functionality of the chip is qualified.

2 - The maximum absolute rated junction temperature is the junction temperature at which the device can operate without causing damage to the ASIC. This temperature can be measured via the integrated thermal diode described in the next section.

3 - The ambient temperature is defined as the temperature of the local intake air to the thermal management device. The maximum ambient temperature is dependent on the heat sink's local ambient conditions as well as the chassis' external ambient, and the value given here is based on AMD's reference heat sink solution for the RS880D. Refer to Chapter 6 in the *Thermal Design and Analysis Guidelines for the RS880 Product Family*, order# 46139 for heatsink and thermal design guidelines. Refer to Chapter 7 of the above mentioned document for details of ambient conditions.

4 - Thermal Design Power (TDP) is defined as the highest power dissipated while running currently available worst case applications at nominal voltages. Since the core power of modern ASICs using 65nm and smaller process technology can vary significantly, parts specifically screened for higher core power were used for TDP measurement. **The TDP is intended only as a design reference.**

## 5.2.2 Thermal Diode Characteristics

The RS880D has an on-die thermal diode, with its positive and negative terminals connected to the THERMALDIODE\_P and THERMALDIODE\_N pins respectively. Combined with a thermal sensor circuit, the diode temperature, and hence the ASIC temperature, can be derived from a differential voltage reading ( $\Delta V$ ). The equation relating  $T$  to  $\Delta V$  is given below:

$$\Delta V = \frac{\eta \times K \times T \times \ln(N)}{q}$$

where:

$\Delta V$  = Difference of two base-to-emitter voltage readings, one using current =  $I$  and the other using current =  $N \times I$

$N$  = Ratio of the two thermal diode currents (=10 when using an ADI thermal sensor, e.g. ADM 1020, 1030)

$\eta$  = Ideality factor of the diode

$K$  = Boltzman's Constant

$T$  = Temperature in Kelvin

$q$  = Electron charge

The series resistance of the thermal diode ( $R_T$ ) must be taken into account as it introduces an error in the reading (for every  $1.0\Omega$ , approximately  $0.8^\circ\text{C}$  is added to the reading). The sensor circuit should be calibrated to offset the  $R_T$  induced, plus any other known fixed error. Measured values of diode ideality factor and series resistance for the diode circuit are defined in the *Thermal Design and Analysis Guidelines for the RS880 Product Family*, order# 46139.

### 5.3 Package Information

#### 5.3.1 Physical Dimensions

Figure 5-2 and Table 5-14 describe the physical dimensions of the RS880D package. Figure 5-3 shows the detailed ball arrangement for the RS880D.

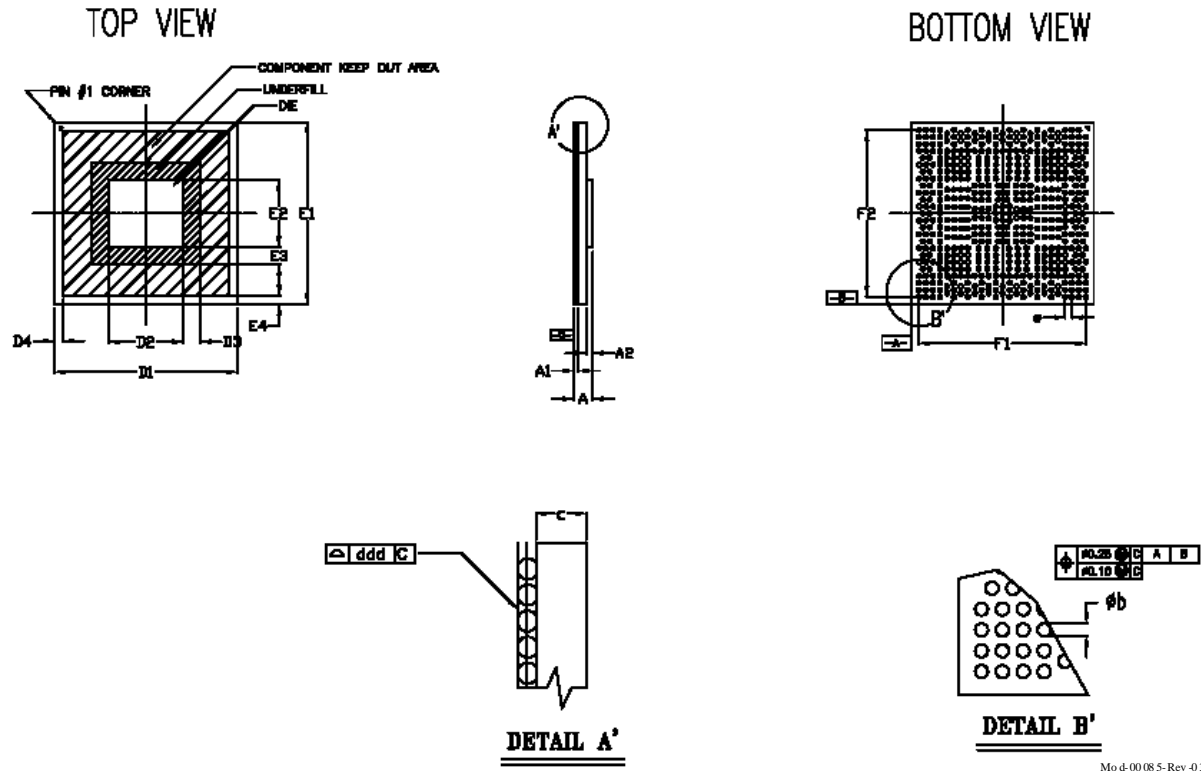

Mo-d-00 08 5-Rev-03

Figure 5-2 RS880D 528-Pin FCBGA Package Outline

Table 5-14 RS880D 528-Pin FCBGA Package Physical Dimensions

Ref.	Min.(mm)	Typical (mm)	Max. (mm)
c	0.48	0.58	0.68
A	1.69	1.84	1.99
A1	0.30	0.40	0.50
A2	0.81	0.86	0.91
$\phi b$	0.40	0.50	0.60
D1	20.85	21.00	21.15
D2	-	8.58	-
D3	2.00	-	-
D4	1.00	-	-
E1	20.85	21.00	21.15
E2	-	7.70	-
E3	2.00	-	-
E4	1.00	-	-
F1	-	19.20	-
F2	-	19.20	-
e1	-	0.80 (min. pitch)	-
ddd	-	-	0.20

Note: Maximum height of SMT components is 0.650 mm.

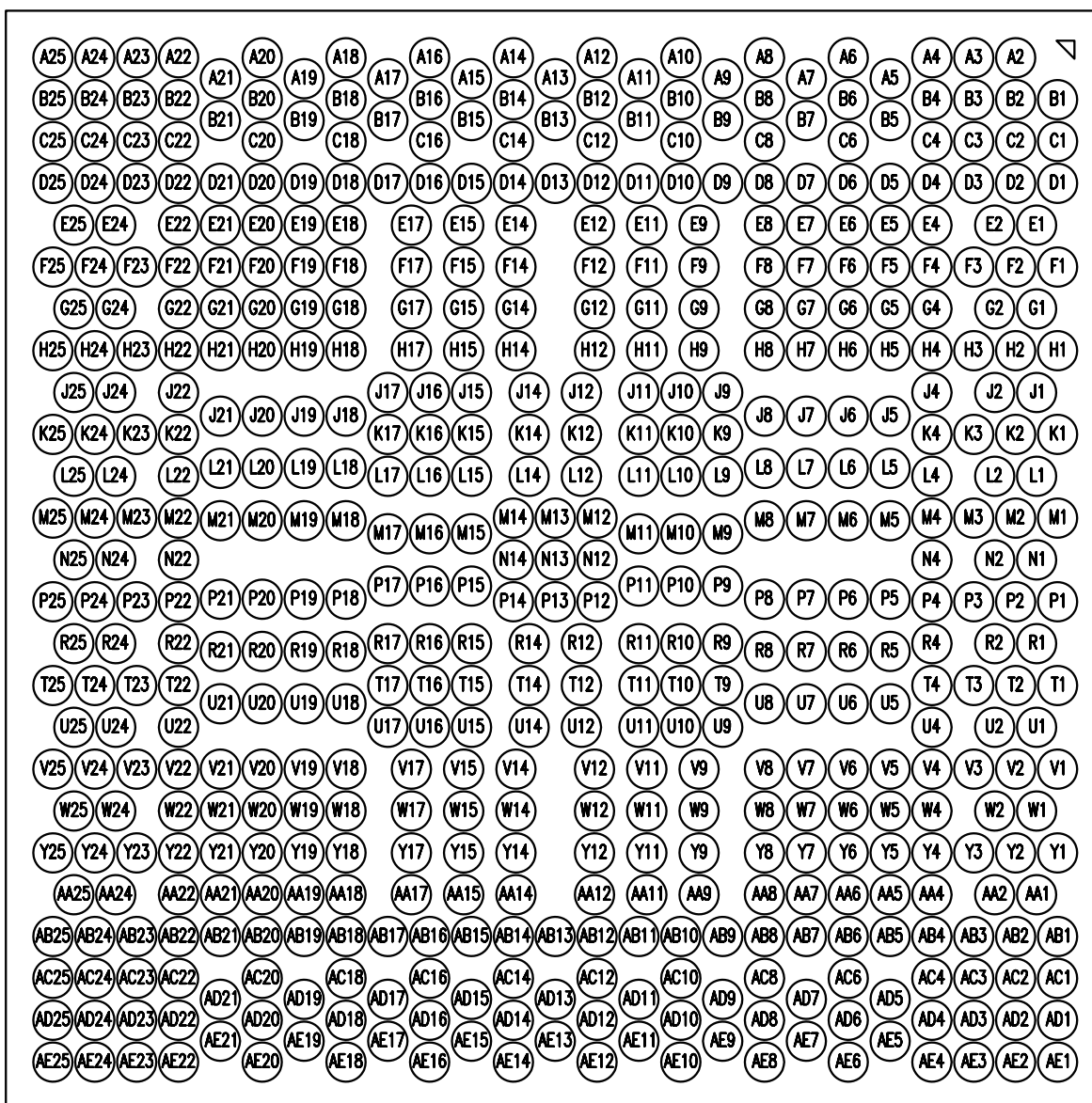

Figure 5-3 RS880D Ball Arrangement (Bottom View)

### 5.3.2 Pressure Specification

To avoid damages to the ASIC (die or solder ball joint cracks) caused by improper mechanical assembly of the cooling device, follow the recommendations below:

- It is recommended that the maximum load that is evenly applied across the contact area between the thermal management device and the die does not exceed 6 lbf. Note that a total load of 4-6 lbf is adequate to secure the thermal management device and achieve the lowest thermal contact resistance with a temperature drop across the thermal interface material of no more than 3°C. Also, the surface flatness of the metal spreader should be 0.001 inch/1 inch.
- Pre-test the assembly fixture with a strain gauge to make sure that the flexing of the final assembled board and the pressure applying around the ASIC package will not exceed 600 micron strain under any circumstances.

- Ensure that any distortion (bow or twist) of the board after SMT and cooling device assembly is within industry guidelines (IPC/EIA J-STD-001). For measurement method, refer to the industry approved technique described in the manual IPC-TM-650, section 2.4.22.

### 5.3.3 Board Solder Reflow Process Recommendations

#### 5.3.3.1 Stencil Opening Size for Solder Paste Pads on PCB

It is recommended that the stencil aperture for solder paste be kept at the same size as that of the land pads. However, for the nine (or eight) pads at each corner of the ASIC package, the size of the openings should not exceed  $400\mu\text{m}$  (see [Figure 5-4](#) below). This recommendation is based on AMD's sample land pattern design for the RS880D, which is available from your AMD CSS representative.

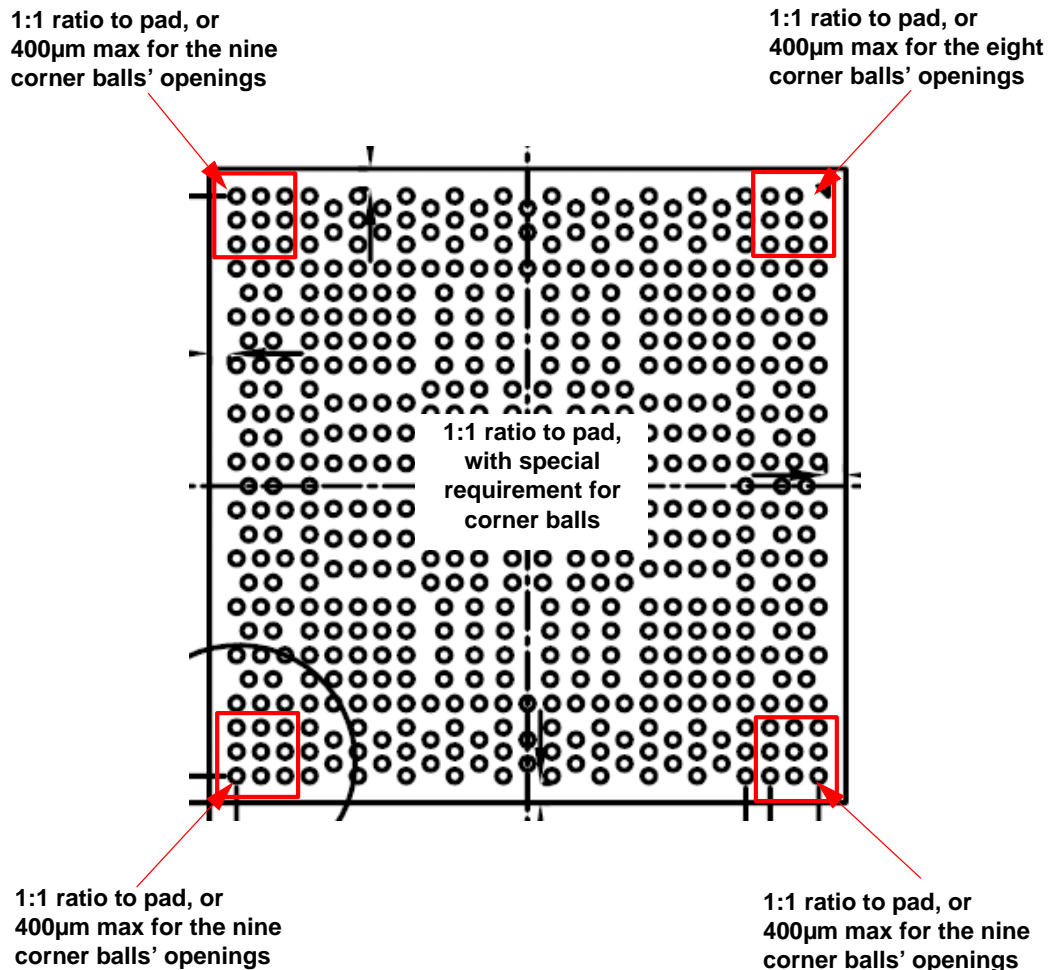

Figure 5-4 Recommended Stencil Opening Sizes for Solder Paste Pads on PCB

#### 5.3.3.2 Reflow Profile

A reference reflow profile is given below. Please note the following when using RoHS/lead-free solder (SAC105/305/405 Tin-Silver-Cu):

- The final reflow temperature profile will depend on the type of solder paste and chemistry of flux used in the SMT process. Modifications to the reference reflow profile may be required in order to accommodate the requirements of the other components in the application.
- An oven with 10 heating zones or above is recommended.
- To ensure that the reflow profile meets the target specification on both sides of the board, a different profile and oven

recipe for the first and second reflow may be required.

- Mechanical stiffening can be used to minimize board warpage during reflow.
- It is suggested to decrease temperature cooling rate to minimize board warpage.
- This reflow profile applies only to RoHS/lead-free (high temperature) soldering process and it should not be used for Eutectic solder packages. Damage may result if this condition is violated.
- Maximum 3 reflows are allowed on the same part.

**Table 5-15 Recommended Board Solder Reflow Profile - RoHS/Lead-Free Solder**

Profiling Stage	Temperature	Process Range
Overall Preheat	Room temp to 220°C	2 mins to 4 mins
Soaking Time	130°C to 170°C	Typical 60 – 80 seconds
Liquidus	220°C	Typical 60 – 80 seconds
Ramp Rate	Ramp up and Cooling	<2°C / second
Peak	Max. 245°C	235°C +/-5°C
Temperature at peak within 5°C	240°C to 245°C	10 – 30 seconds

**Solder/Part Surface Temperature (°C)**

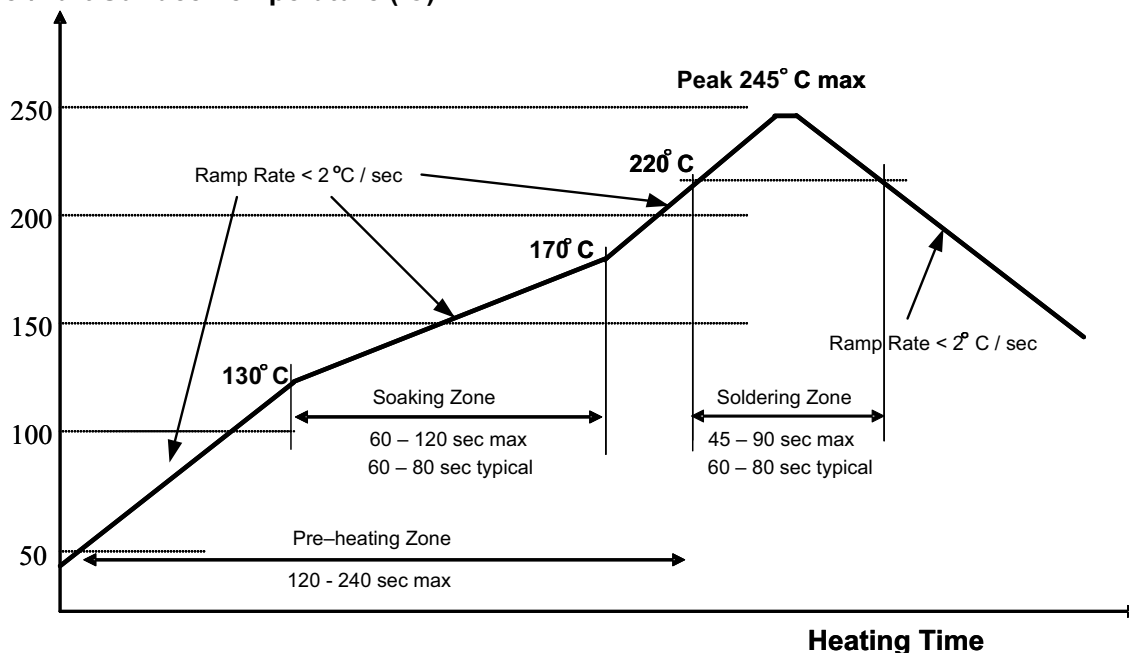

**Figure 5-5 RoHS/Lead-Free Solder (SAC305/405 Tin-Silver-Copper) Reflow Profile**

This page is left blank intentionally.

# Chapter 6

## Power Management and ACPI

### 6.1 ACPI Power Management Implementation

This chapter describes the support for ACPI power management provided by the RS880D. The RS880D Northbridge supports ACPI Revision 2.0. The hardware, system BIOS, video BIOS, and drivers of the RS880D have all the logic required for meeting the power management specifications of PC2001, OnNow, and the Windows Logo Program and Device Requirements version 2.1. *Table 6-1, “ACPI States Supported by the RS880D,”* describes the ACPI states supported by the RS880D. *Table 6-2, “ACPI Signal Definitions,”* describes the signals used in the ACPI power management scheme of the RS880D.

**Table 6-1 ACPI States Supported by the RS880D**

ACPI State	Description
Graphics States:	
D0	Full on, display active.
D1	Display Off. RS880D power on. Configuration registers, state, and main memory contents retained.
D3 Hot	Similar to D1, with additional power saving and the graphics PLLs shut off.
D3 Cold	RS880D power off.
Processor States:	
S0/C0: Working State	Working State. The processor is executing instructions.
S0/C1: Halt	CPU Halt state. No instructions are executed. This state has the lowest latency on resume and contributes minimum power savings.
S0/C2: Stop Grant Caches Snoopable	Stop Grant or Cache Snoopable CPU state. This state offers more power savings but has a higher latency on resume than the C1 state.
S0/C3/C1e: Stop Grant Caches Snoopable	Processor is put into Stop Grant state. Caches are still snoopable. The HyperTransport™ link may be disconnected and put into a low power state. System memory may be put into self-refresh.
System States:	
S1: Standby Powered On Suspend	System is in Standby mode. This state has low wakeup latency on resume. OEM support of this state is optional.
S3: Standby Suspend to RAM	System is off but context is saved to RAM. OEM support of this state is optional. System memory is put into self-refresh.
S4: Hibernate Suspend to Disk	System is off but context is saved to disk. When the system transitions to the working state, the OS is resumed without a system re-boot.
S5: Soft Off	System is off. OS re-boots when the system transitions to the working state.
G3: Mechanical Off	Occurs when system power (AC or battery) is not present or is unable to keep the system in one of the other states.

**Note:** Also supported are additional processor power states that are not part of the ACPI specification, e.g. C1E (C1 Enhanced) and C3 pop-up. Please refer to the relevant Southbridge databook and the *RS880 ASIC Family Register Programming Requirements*, order# 46141, for more information.

**Table 6-2 ACPI Signal Definitions**

Signal Name	Description	Source
ALLOW_LDTSTOP	Output to the Southbridge to allow LDTSTOP# assertion.	Northbridge
LDTSTOP#	HyperTransport™ Technology Stop: Enables and disables links during system state transitions.	Southbridge
POWERON#	Power On	Power switch
RESET#	Global Reset	Southbridge

## 6.2 Power Management for the Graphics Controller

The RS880D supports power management for the embedded graphics device as specified by the PCI Bus Power Management Interface Specification version 1.0, according to which the integrated graphics core of the RS880D qualifies as a device embedding a single function in the power management system.

### 6.2.1 PCI Function Power States

There are up to four power states defined for each PCI function associated with each PCI device in the system. These power states are D0, D1, D2 and D3. D0 (on) consumes the most power while D3 (off) consumes the least. D1 and D2 enable levels of power savings in between those of D0 and D3. The concepts of these power states are universal for all functions in the system. When transitioned to a given power management state, the intended functional behavior is dependent upon the type (or class) of the function.

### 6.2.2 PCI Power Management Interface

The four basic power management operations are:

- Capabilities Reporting
- Power Status Reporting
- Setting Power State
- System Wakeup

All four of these capabilities are required for each power management function with the exception of wakeup event generation.

This section describes the format of the registers in the PCI Configuration Space that are used by these power management operations. The Status and Capabilities Pointer (CAP\_PTR) fields have been highlighted to indicate where the PCI Power Management features appear in the standard Configuration Space Header.

**Table 6-3 Standard PCI Configuration Space Header Type 0**

RegisterFields(32Bits)				Offset
MSB		LSB		
Device ID		Vendor ID		00h (LSB)
Status (with Bit 4 set to 1)		Command		04h
Class Code		Revision ID		08h
BIST	Header Type	Latency Timer	Cache Line Size	0Ch
Base Address Registers				10h
				14h
				18h
				1Ch
				20h
				24h
CardBus CIS Pointer				28h
Subsystem ID		Subsystem Vendor ID		2Ch
Expansion ROM Base Address				30h
Reserved			CAP_PTR	34h
Reserved				38h
Max_Lat	Min_Gnt	Interrupt Pin	Interrupt Line	3Ch

### 6.2.3 Capabilities List Data Structure in PCI Configuration Space

The Capabilities bit in the PCI Status register (offset = 06h) indicates whether or not the subject function implements a linked list of extended capabilities. Specifically, if bit 4 is set, the CAP\_PTR register is implemented to give offset to the first item in the Capabilities link list.

**Table 6-4 PCI Status Register**

Bits	Default Value	Read/Write	Description
15:05	--	--	Refer to <i>PCI Local Bus Specification, Revision 2.2</i>
04	1b	Read Only	This bit indicates whether this function implements a list of extended capabilities such as PCI power management. When set, this bit indicates the presence of Capabilities. A value of 0 implies that this function does not implement Capabilities.
03:00	0h	Read Only	Reserved

The location of the Capabilities Pointer (CAP\_PTR) depends on the PCI header type. See *PCI Specification Revision 2.2* for specification of CAP\_PTR offsets.

**Table 6-5 Capabilities Pointer (CAP\_PTR)**

Bits	Default Value	Read/Write	Description
07:00	50h	Read Only	The CAP_PTR provides an offset in the PCI Configuration Space of the function to access the location of the first item in the Capabilities linked list. The CAP_PTR offset is DWORD aligned, so that the two least significant bits are always zeros.

The graphics core implements extended capabilities of the AGP and Power Management. It needs to provide the standardized register interface. The first entry in the chain of descriptors has to be the PMI descriptor, as this functionality will be supported even if the RS880D operates as a PCI device. The Capabilities Identifier for Power Management is 01h.

#### 6.2.4 Register Block Definition

This section describes the PCI Power Management Interface registers. These registers are implemented inside the Host Interface (HI) as part of the configuration space of the device (RS880D).

**Table 6-6 Power Management Register Block**

Register Fields	Offset
Capability Identifiers (CAP_ID)	00h
Next Item Pointer (NEXT_ITEM_PTR)	01h
Power Management Capabilities (PMC)	02h
Power Management Control/Status Register (PMCSR)	04h
Reserved	06h

The first 16 bits (Capabilities ID [offset = 0] and Next Item Pointer [offset = 1]) are used for the linked list infrastructure. The next 32 bits (PMC [offset = 2] and PMCSR registers [offset = 4]) are required for compliance with this specification.

As with all PCI configuration registers, these registers may be accessed as bytes, 16-bit words, or 32-bit DWORDs. All of the write operations to the reserved registers must be treated as no-ops. This implies that the access must be completed normally on the bus and the data should be discarded. Read accesses to the reserved or the unimplemented registers must be completed normally and a data value of 0000h should be returned.

**Table 6-7 Power Management Control/Status Register (PMCSR)**

Field Name	Bits	Default (Reset)	Description	
Power State	1:0	00	This field describes the power state of the graphics core.	
			States	Function
			00 = D0	Normal operation, no power savings enabled
			01 = D1	Sleeping state 1: Display is off Host access to DRAM is allowed
			10 = D2	Sleeping state 2 Display is off. All engines are off. Graphics core does not respond to host accesses to the frame buffer.
	11 = D3	Everything, except Host Interface, is turned off.		
Power State	15:2	0	These Read Only bits will return the clock status of each clock tree, generated inside the clock block.	

The offset for each register is listed as an offset from the beginning of the linked list item that is determined either from the CAP\_PTR (if Power Management is the first item in the list) or the NEXT\_ITEM\_PTR of the previous item in the list.

### 6.2.5 Capability Identifier: CAP\_ID (Offset = 0)

The Capability Identifier, when read by system software as 01h, indicates that the data structure currently being pointed to is the PCI Power Management data structure. Each function of a PCI device may have only one item in its capability list with CAP\_ID set to 01h.

**Table 6-8 Capability Identifier (CAP\_ID)**

Bits	Default Value	Read/Write	Description
07:00	01h	Read Only	This field, when set to 01h, identifies the linked list item as being the PCI Power Management registers

*Figure 6-1, 'Linked List for Capabilities,'* shows the implementation of the capabilities list. The CAP\_PTR gives the location of the first item in the list. PCI Power Management registers have been stated as example in this list (although the capabilities can be in any order).

- The first byte of each entry is required to be the ID of that capability. The PCI Power Management capability has an ID of 01h.
- The next byte is a pointer giving an absolute offset in the functions PCI Configuration Space to the next item in the list and must be DWORD aligned.
- If there are no more entries in the list, the NEXT\_ITEM\_PTR must be set to 0 to indicate an end of the linked list. Each capability can then have registers following the NEXT\_ITEM\_PTR.

The definition of these registers (including layout, size, and bit definitions) is specific to each capability. The PCI Power Management Register Block is defined in *Figure 6-1, 'Linked List for Capabilities,'* below.

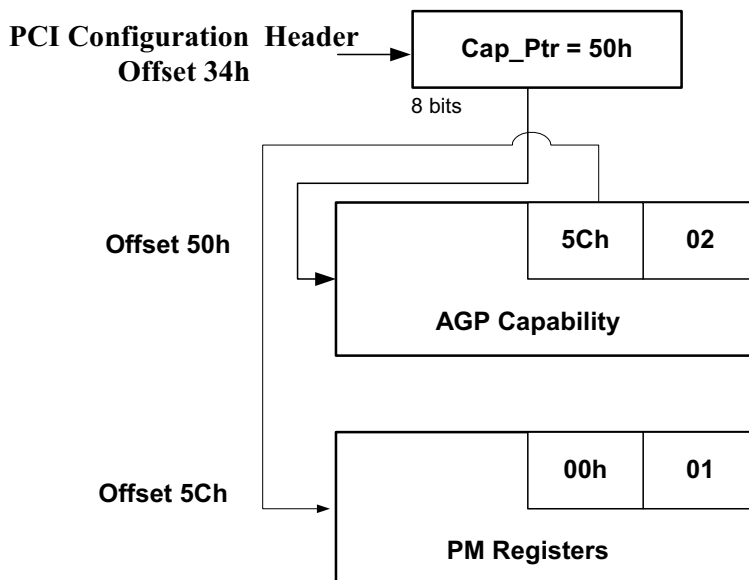

Figure 6-1 Linked List for Capabilities

### 6.2.6 Next Item Pointer (Offset = 1)

The Next Item Pointer register describes the location of the next item in the capability list of the function. The value given is an offset in the PCI Configuration Space of that function. This register must be set to 00h if the function does not implement any other capabilities defined by the PCI Specifications for inclusion in the capabilities list, or if power management is the last item in the list.

Table 6-9 Next Item Pointer (NEXT\_ITEM\_PTR)

Bits	Default Value	Read/Write	Description
07:00	80h	Read Only	This field provides an offset in the PCI Configuration Space of the function pointing to the location of next item in the capability list of the function. For Power Management of the RS880D, this pointer is set to 80h and it points to the next capability pointer of the MSI structure.

### 6.2.7 PMC - Power Management Capabilities (Offset = 2)

The Power Management Capabilities register is a 16-bit Read Only register that provides information on the capabilities of the function related to power management. The information in this register is generally static and is known at design time.

**Table 6-10 Power Management Capabilities – PMC**

Bits	Default Value	Read/Write	Description
15:11	00111b	Read Only	This 5-bit field indicates the power states in which the function may assert PME#. A value of 0b for any bit indicates that the function is not capable of asserting the PME# signal while in that power state. bit(11) XXXX1b - PME# can be asserted from D0. bit(12) XXX1Xb - PME# can be asserted from D1. bit(13) XX1XXb - PME# can be asserted from D2. bit(14) X0XXXb - PME# cannot be asserted from D3hot. bit(15) 0XXXXb - PME# cannot be asserted from D3cold.
10	001b	Read Only	RS880D supports D2.
09	001b	Read Only	RS880D supports D1.
08:06	000b	Read Only	Reserved
05	1b	Read Only	The Device Specific Initialization bit indicates whether special initialization of this function is required (beyond the standard PCI configuration header) before the generic class device driver is able to use it. The RS880D requires device specific initialization after Reset; this field must therefore return a value 1 to the system.
04	0b	Read Only	Reserved
03	0b	Read Only	Reserved
02:00	001b	Read Only	A value of 001b indicates that this function complies with Revision 1.0 of the PCI Power Management Interface Specification.

# Chapter 7

## Testability

### 7.1 Test Capability Features

The RS880D has integrated test modes and capabilities. These test features cover both the ASIC and board level testing. The ASIC tests provide a very high fault coverage and low DPM (Defect Per Million) ratio of the part. The board level tests modes can be used for motherboard manufacturing and debug purposes. The following are the test modes of the RS880D:

- Full scan implementation on the digital core logic that provides about 99% fault coverage through ATPG (Automatic Test Pattern Generation Vectors).
- Dedicated test logic for the on-chip custom memory macros to provide complete coverage on these modules.
- Improved access to the analog modules and PLLs in the RS880D to allow full evaluation and characterization of these modules.
- A JTAG test mode (which is not entirely compliant to the IEEE 1149.1 standard) to allow board level testing of neighboring devices.
- An XOR TREE test mode on all the digital I/O's to allow for proper soldering verification at the board level.
- A VOH/VOL test mode on all digital I/O's to allow for proper verification of output high and output low voltages at the board level.

These test modes can be accessed through the settings on the instruction register of the JTAG circuitry.

### 7.2 Test Interface

**Table 7-1 Pins on the Test Interface**

Pin Name	Ball number	Type	Description
TESTMODE	D13	I	IEEE 1149.1 test port reset
DDC_DATA0/AUX0N	B8	I	TMS: Test Mode Select (IEEE 1149.1 test mode select)
I2C_DATA	A9	I	TDI: Test Mode Data In (IEEE 1149.1 data in)
I2C_CLK	B9	I	TCLK: Test Mode Clock (IEEE 1149.1 clock)
TMDS_HPD	D9	O	TDO: Test Mode Data Out (IEEE 1149.1 data out)
POWERGOOD	A10	I	I/O Reset

### 7.3 XOR Test

#### 7.3.1 Description of a Generic XOR Tree

An example of a generic XOR tree is shown in the [Figure 7-1](#).

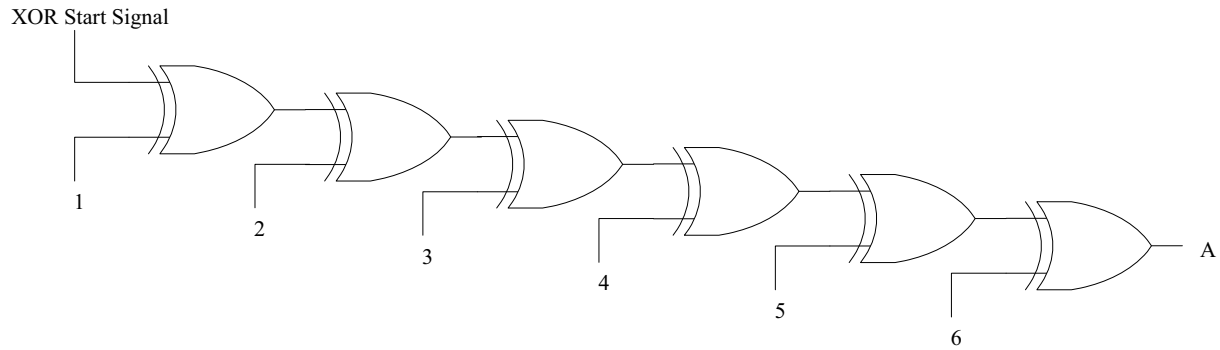

Figure 7-1 Example of a Generic XOR Tree

Pin A is assigned to the output direction, and pins 1 through 6 are assigned to the input direction. It can be seen that after all pins 1 to 6 are assigned to logic 0 or 1, a logic change in any one of these pins will toggle the output pin A.

The following is the truth table for the XOR tree shown in [Figure 7-1](#). The XOR start signal is assumed to be logic 1.

Table 7-2 Example of an XOR Tree

Test Vector number	Input Pin 1	Input Pin 2	Input Pin 3	Input Pin 4	Input Pin 5	Input Pin 6	Output Pin A
1	0	0	0	0	0	0	1
2	1	0	0	0	0	0	0
3	1	1	0	0	0	0	1
4	1	1	1	0	0	0	0
5	1	1	1	1	0	0	1
6	1	1	1	1	1	0	0
7	1	1	1	1	1	1	1

### 7.3.2 Description of the RS880D XOR Tree

#### 7.3.3 XOR Tree Activation

The RS880D chip enters the XOR tree test mode by means of the JTAG. First, the 8-bit instruction register of the JTAG is loaded with the XOR instruction (“00001000”). This instruction assigns the input direction to all the pins except pin TDO, which is assigned the output direction to serve as the output of the XOR tree. After loading, the JTAG is taken to the Run-Test state for completion of the XOR tree initialization.

A 10MHz clock frequency for the Test Mode Clock (I2C\_CLK) is recommended for the XOR TREE test mode. A pair of differential clock at 10MHz should also be supplied to HT\_REFCLKP/N to enable I/Os for testing.

#### 7.3.4 XOR Tree for the RS880D

The XOR start signal is applied at the TDI Pin of the JTAG circuitry and the output of the XOR tree is obtained at the TDO Pin. Refer to [Table 7-3](#) for the list of the signals included on the XOR tree. A toggle of any of these balls in the XOR tree will cause the output to toggle.

There is no specific connection order to the signals on the tree. When the XOR tree is activated, any pin on the XOR tree must be either pulled down or pulled up to the I/O voltage of the pin. Only pins that are **not** on the XOR tree can be left floating.

When differential signal pairs are listed as single entries on the XOR tree, opposite input values should be applied to the two signals in each pair (e.g., for entry no. 1 on the tree, when “1” is applied to HT\_RXCAD0P, “0” should be applied to HT\_RXCAD0N).

Table 7-3 RS880D XOR Tree

No.	Pin Name	Ball Reference
1	HT_RXCAD0P/N	Y25/Y24
2	HT_RXCAD1P/N	V22/V23
3	HT_RXCAD2P/N	V25/V24
4	HT_RXCAD3P/N	U24/U25
5	HT_RXCAD4P/N	T25/T24
6	HT_RXCAD5P/N	P22/P23
7	HT_RXCAD6P/N	P25/P24
8	HT_RXCAD7P/N	N24/N25
9	HT_RXCAD8P/N	AC24/AC25
10	HT_RXCAD9P/N	AB25/AB24
11	HT_RXCAD10P/N	AA24/AA25
12	HT_RXCAD11P/N	Y22/Y23
13	HT_RXCAD12P/N	W21/W20
14	HT_RXCAD13P/N	V21/V20
15	HT_RXCAD14P/N	U20/U21
16	HT_RXCAD15P/N	U19/U18
17	HT_RXCTL0P/N	M22/M23
18	HT_RXCTL1P/N	R21/R20
19	MEM_CKE	AB18
20	MEM_CS#	AB13
21	MEM_ODT	V14
22	MEM_WE#	AD18
23	MEM_RAS#	W12
24	MEM_CAS#	Y12
25	MEM_BA0	AD16
26	MEM_BA1	AE17
27	MEM_BA2	AD17
28	MEM_A0	AB12
29	MEM_A1	AE16
30	MEM_A2	V11
31	MEM_A3	AE15
32	MEM_A4	AA12
33	MEM_A5	AB16
34	MEM_A6	AB14
35	MEM_A7	AD14

No.	Pin Name	Ball Reference
36	MEM_A8	AD13
37	MEM_A9	AD15
38	MEM_A10	AC16
39	MEM_A11	AE13
40	MEM_A12	AC14
41	MEM_A13	Y14
42	MEM_DQ0	AA18
43	MEM_DQ1	AA20
44	MEM_DQ2	AA19
45	MEM_DQ3	Y19
46	MEM_DQ4	V17
47	MEM_DQ5	AA17
48	MEM_DQ6	AA15
49	MEM_DQ7	Y15
50	MEM_DQ8	AC20
51	MEM_DQ9	AD19
52	MEM_DQ10	AE22
53	MEM_DQ11	AC18
54	MEM_DQ12	AB20
55	MEM_DQ13	AD22
56	MEM_DQ14	AC22
57	MEM_DQ15	AD21
58	MEM_DM0	W17
59	MEM_DM1	AE19
60	MEM_DQS0P/N	Y17/W18
61	MEM_DQS1P/N	AD20/AE21
62	MEM_CKP/N	V15/W14
63	GFX_RX0P/N	D4/C4
64	GFX_RX1P/N	A3/B3
65	GFX_RX2P/N	C2/C1
66	GFX_RX3P/N	E5/F5
67	GFX_RX4P/N	G5/G6
68	GFX_RX5P/N	H5/H6
69	GFX_RX6P/N	J6/J5
70	GFX_RX7P/N	J7/J8

No.	Pin Name	Ball Reference
71	GFX_RX8P/N	L5/L6
72	GFX_RX9P/N	M8/L8
73	GFX_RX10P/N	P7/M7
74	GFX_RX11P/N	P5/M5
75	GFX_RX12P/N	R8/P8
76	GFX_RX13P/N	R6/R5
77	GFX_RX14P/N	P4/P3
78	GFX_RX15P/N	T4/T3
79	GPP_RX0P/N	AE3/AD4
80	GPP_RX1P/N	AE2/AD3
81	GPP_RX2P/N	AD1/AD2
82	GPP_RX3P/N	V5/W6
83	GPP_RX4P/N	U5/U6
84	GPP_RX5P/N	U8/U7
85	SB_RX0P/N	AA8/Y8
86	SB_RX1P/N	AA7/Y7
87	SB_RX2P/N	AA5/AA6
88	SB_RX3P/N	W5/Y5
89	GPIO3	E9
90	GPIO4	G12
91	GPIO2	F7
92	DAC_HSYNC	A11
93	DAC_VSYNC	B11
94	DAC_SCL	F8
95	DDC_CLK0/AUX0P	A8
96	HPD	D10
97	DDC_DATA1/AUX1N	A7
98	DDC_CLK1/AUX1P	B7

## 7.4 VOH/VOL Test

### 7.4.1 Description of a Generic VOH/VOL Tree

The VOH/VOL logic gives signal output on I/O's when test patterns are applied through the TEST\_ODD and TEST\_EVEN inputs. Sample of a generic VOH/VOL tree is shown in [Figure 7-2](#).

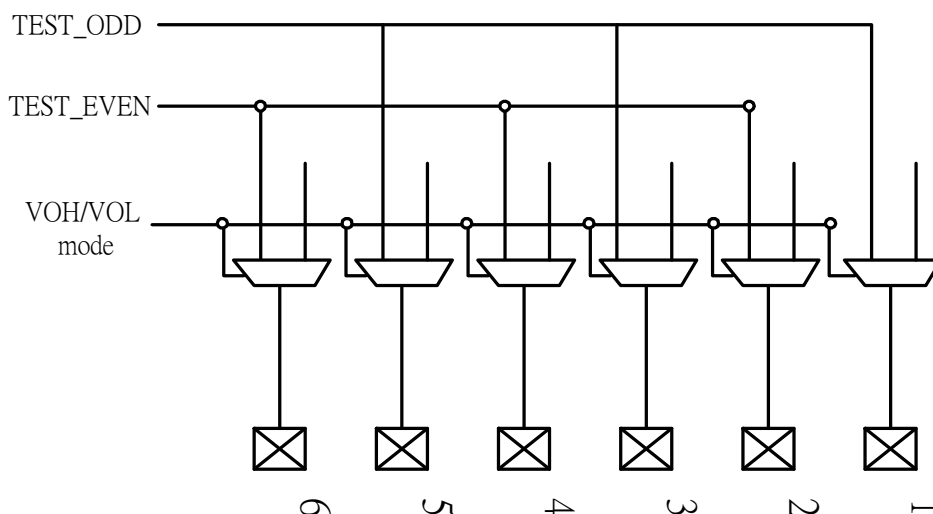

Figure 7-2 Sample of a Generic VOH/VOL Tree

The following is the truth table for the above VOH/VOL tree.

Table 7-4 Truth Table for the VOH/VOL Tree Outputs

Test Vector Number	TEST_ODD Input	TEST_EVEN Input	Output Pin 1	Output Pin 2	Output Pin 3	Output Pin 4	Output Pin 5	Output Pin 6
1	0	0	0	0	0	0	0	0
2	0	1	0	1	0	1	0	1
3	1	0	1	0	1	0	1	0
4	1	1	1	1	1	1	1	1

Refer to [Section 7.4.3](#) for the list of pins that are on the VOH/VOL tree. VOH/VOL Tree Activation

## 7.4.2 VOH/VOL Tree Activation

To activate the VOH/VOL tree and run a VOH/VOL test, perform the sequence below:

1. Supply a 10MHz clock to the REFCLK\_P pin and a 10MHz differential clock pair to the HT\_REFCLKP/N pins to enable I/Os for testing.
2. Set POWERGOOD to 0.
3. Set TESTMODE to 1.
4. Set DAC\_SDA to 0.
5. Load JTAG instruction register with the instruction 0110 0011.
6. Load JTAG instruction register with the instruction 0010 0111.
7. Set POWERGOOD to 1.

8. Load JTAG instruction register with the instruction 1001 1001.
9. Run test by loading JTAG data register with data 0000 0000 0000 00xy, where bit x is the input value for TEST\_ODD and bit y that for TEST\_EVEN (see Table 7-4 above).
10. To end test, load JTAG instruction register with the instruction 0101 1101.

### 7.4.3 VOH/VOL Pin List

Table 7-5 shows the RS880D VOH/VOL tree. There is no specific order for connection. Under the Control column, an “ODD” or “EVEN” indicates that the logical output of the pin is same as the “TEST\_ODD” or “TEST\_EVEN” input respectively.

When a differential pair appear in the table as a single entry, the output of the positive (“P”) pin is indicated in the Control column (see last paragraph for explanations), and the output of the negative pin (“N”) will be of the opposite value. For example, for entry no. 1 on the tree, when TEST\_EVEN is 1, HT\_TXCAD0P will give a value of 1 and HT\_TXCAD0N will give a value of 0.

Table 7-5 RS880D VOH/VOL Tree

No.	Pin Name	Ball Reference	Control
1	HT_TXCAD0P/N	D24/D25	Even
2	HT_TXCAD1P/N	E24/E25	Odd
3	HT_TXCAD2P/N	F24/F25	Even
4	HT_TXCAD3P/N	F23/F22	Odd
5	HT_TXCAD4P/N	H23/H22	Even
6	HT_TXCAD5P/N	J25/J24	Odd
7	HT_TXCAD6P/N	K24/K25	Even
8	HT_TXCAD7P/N	K23/K22	Odd
9	HT_TXCAD8P/N	F21/G21	Even
10	HT_TXCAD9P/N	G20/H21	Odd
11	HT_TXCAD10P/N	J20/J21	Even
12	HT_TXCAD11P/N	J18/K17	Odd
13	HT_TXCAD12P/N	L19/J19	Even
14	HT_TXCAD13P/N	M19/L18	Odd
15	HT_TXCAD14P/N	M21/P21	Even
16	HT_TXCAD15P/N	P18/M18	Odd
17	HT_TXCTL0P/N	M24/M25	Even
18	HT_TXCTL1P/N	P19/R18	Odd
19	MEM_DQ0	AA18	Even
20	MEM_DQ1	AA20	Odd
21	MEM_DQ2	AA19	Even
22	MEM_DQ3	Y19	Odd
23	MEM_DQ4	V17	Even
24	MEM_DQ5	AA17	Odd
25	MEM_DQ6	AA15	Even
26	MEM_DQ7	Y15	Odd
27	MEM_DQ8	AC20	Even
28	MEM_DQ9	AD19	Odd
29	MEM_DQ10	AE22	Even
30	MEM_DQ11	AC18	Odd
31	MEM_DQ12	AB20	Even
32	MEM_DQ13	AD22	Odd
33	MEM_DQ14	AC22	Even
34	MEM_DQ15	AD21	Odd
35	MEM_DM0	W17	Even

No.	Pin Name	Ball Reference	Control
36	MEM_DM1	AE19	Odd
37	MEM_DQS0P/N	Y17/W18	Even
38	MEM_DQS1P/N	AD20/AE21	Odd
39	MEM_CKE	AB18	Even
40	MEM_CS#	AB13	Odd
41	MEM_ODT	V14	Even
42	MEM_WE#	AD18	Odd
43	MEM_RAS#	W12	Even
44	MEM_CAS#	Y12	Odd
45	MEM_BA0	AD16	Even
46	MEM_BA1	AE17	Odd
47	MEM_BA2	AD17	Even
48	MEM_A0	AB12	Odd
49	MEM_A1	AE16	Even
50	MEM_A2	V11	Odd
51	MEM_A3	AE15	Even
52	MEM_A4	AA12	Odd
53	MEM_A5	AB16	Even
54	MEM_A6	AB14	Odd
55	MEM_A7	AD14	Even
56	MEM_A8	AD13	Odd
57	MEM_A9	AD15	Even
58	MEM_A10	AC16	Odd
59	MEM_A11	AE13	Even
60	MEM_A12	AC14	Odd
61	MEM_A13	Y14	Even
62	MEM_CKP/N	V15/W14	Odd
63	GFX_TX0P/N	A5/B5	Even
64	GFX_TX1P/N	A4/B4	Odd
65	GFX_TX2P/N	C3/B2	Even
66	GFX_TX3P/N	D1/D2	Odd
67	GFX_TX4P/N	E2/E1	Even
68	GFX_TX5P/N	F4/F3	Odd
69	GFX_TX6P/N	F1/F2	Even
70	GFX_TX7P/N	H4/H3	Odd

No.	Pin Name	Ball Reference	Control
71	GFX_TX8P/N	H1/H2	Even
72	GFX_TX9P/N	J2/J1	Odd
73	GFX_TX10P/N	K4/K3	Even
74	GFX_TX11P/N	K1/K2	Odd
75	GFX_TX12P/N	M4/M3	Even
76	GFX_TX13P/N	M1/M2	Odd
77	GFX_TX14P/N	N2/N1	Even
78	GFX_TX15P/N	P1/P2	Odd
79	GPP_TX0P/N	AC1/AC2	Even
80	GPP_TX1P/N	AB4/AB3	Odd
81	GPP_TX2P/N	AA2/AA1	Even
82	GPP_TX3P/N	Y1/Y2	Odd
83	GPP_TX4P/N	Y4/Y3	Even
84	GPP_TX5P/N	V1/V2	Odd
85	SB_TX0P/N	AD7/AE7	Even
86	SB_TX1P/N	AE6/AD6	Odd
87	SB_TX2P/N	AB6/AC6	Even
88	SB_TX3P/N	AD5/AE5	Odd
89	GPIO2	F7	Even
90	GPIO4	G12	Odd
91	GPIO3	E9	Even
92	DAC_VSYNC	B11	Odd
93	DAC_HSYNC	A11	Even
94	HPD	D10	Odd

---

# Appendix A

## *Pin Listings*

---

This appendix contains pin listings for the RS880D sorted in different ways. To go to the listing of interest, use the linked cross-references below:

[\*“RS880D Pin List Sorted by Ball Reference” on page A-2\*](#)

[\*“RS880D Pin List Sorted by Pin Name” on page A-7\*](#)

## A.1 RS880D Pin List Sorted by Ball Reference

Table A-1 RS880D Pin List Sorted by Ball Reference

Ball Ref	Pin Name	Ball Ref	Pin Name	Ball Ref	Pin Name
A10	POWERGOOD	AA8	SB_RX0P	AC8	PCE_CALRP
A11	DAC_HSYNC	AA9	VDDA18PCIE	AD1	GPP_RX2P
A12	PLLVD	AB1	VSSAPCIE	AD10	VDD_MEM
A13	VDDLTP18	AB10	VDD_MEM	AD11	VDD18_MEM
A14	VDDLTP33	AB11	VSS	AD12	MEM_COMPN
A15	VDDLTP18	AB12	MEM_A0	AD13	MEM_A8
A16	TXCLK_LN	AB13	MEM_CS#	AD14	MEM_A7
A17	TXOUT_U1P	AB14	MEM_A6	AD15	MEM_A9
A18	TXOUT_U0N	AB15	VSS	AD16	MEM_BA0
A19	TXOUT_L3P	AB16	MEM_A5	AD17	MEM_BA2
A2	VSSAPCIE	AB17	VSS	AD18	MEM_WE#
A20	TXOUT_L2N	AB18	MEM_CKE	AD19	MEM_DQ9
A21	TXOUT_L1P	AB19	VSS	AD2	GPP_RX2N
A22	TXOUT_L0P	AB2	VSSAPCIE	AD20	MEM_DQS1P
A23	VDDHTRX	AB20	MEM_DQ12	AD21	MEM_DQ15
A24	HT_RXCALN	AB21	VSS	AD22	MEM_DQ13
A25	VSSAHT	AB22	VDDHTTX	AD23	IOPLLVDSS
A3	GFX_RX1P	AB23	HT_RXCLK1P	AD24	VDDHTTX
A4	GFX_TX1P	AB24	HT_RXCAD9N	AD25	VSSAHT
A5	GFX_TX0P	AB25	HT_RXCAD9P	AD3	GPP_RX1N
A6	VDDPCIE	AB3	GPP_TX1N	AD4	GPP_RX0N
A7	DDC_DATA1/AUX1N	AB4	GPP_TX1P	AD5	SB_TX3P
A8	DDC_CLK0/AUX0P	AB5	VSSAPCIE	AD6	SB_TX1N
A9	I2C_DATA	AB6	SB_TX2P	AD7	SB_TX0P
AA1	GPP_TX2N	AB7	VSSAPCIE	AD8	THERMALDIODE_N
AA11	VDD_MEM	AB8	PCE_CALRN	AD9	VDDA18PCIE
AA12	MEM_A4	AB9	VDDA18PCIE	AE1	VSSAPCIE
AA14	VSS	AC1	GPP_TX0P	AE10	VDD_MEM
AA15	MEM_DQ6	AC10	VDD_MEM	AE11	VDD18_MEM
AA17	MEM_DQ5	AC12	VSS	AE12	MEM_COMPP
AA18	MEM_DQ0	AC14	MEM_A12	AE13	MEM_A11
AA19	MEM_DQ2	AC16	MEM_A10	AE14	VSS
AA2	GPP_TX2P	AC18	MEM_DQ11	AE15	MEM_A3
AA20	MEM_DQ1	AC2	GPP_TX0N	AE16	MEM_A1
AA21	VDDHTTX	AC20	MEM_DQ8	AE17	MEM_BA1
AA22	HT_RXCLK1N	AC22	MEM_DQ14	AE18	MEM_VREF
AA24	HT_RXCAD10P	AC23	VDDHTTX	AE19	MEM_DM1
AA25	HT_RXCAD10N	AC24	HT_RXCAD8P	AE2	GPP_RX1P
AA4	VSSAPCIE	AC25	HT_RXCAD8N	AE20	VSS
AA5	SB_RX2P	AC3	VSSAPCIE	AE21	MEM_DQS1N
AA6	SB_RX2N	AC4	VSSAPCIE	AE22	MEM_DQ10
AA7	SB_RX1P	AC6	SB_TX2N	AE23	IOPLLVD18

Ball Ref	Pin Name
AE24	IOPLLVD
AE25	VDDHTTX
AE3	GPP_RX0P
AE4	VSSAPCIE
AE5	SB_TX3N
AE6	SB_TX1P
AE7	SB_TX0N
AE8	THERMALDIODE_P
AE9	VDDA18PCIE
B1	VSSAPCIE
B10	STRP_DATA
B11	DAC_VSYNC
B12	PLLVSS
B13	VSSLTP18
B14	VDDL33
B15	VDDL18
B16	TXCLK_LP
B17	TXOUT_U1N
B18	TXOUT_U0P
B19	TXOUT_L3N
B2	GFX_TX2N
B20	TXOUT_L2P
B21	TXOUT_L1N
B22	TXOUT_L0N
B23	VDDHTRX
B24	HT_TXCALP
B25	HT_TXCALN
B3	GFX_RX1N
B4	GFX_TX1N
B5	GFX_TX0N
B6	VDDPCIE
B7	DDC_CLK1/AUX1P
B8	DDC_DATA0/AUX0N
B9	I2C_CLK
C1	GFX_RX2N
C10	LDTSTOP#
C12	ALLOW_LDTSTOP
C14	VSSLT
C16	VSSLT
C18	VSSLT
C2	GFX_RX2P
C20	VSSLT
C22	VSSLT
C23	HT_RXCALP

Ball Ref	Pin Name
C24	HT_REFCLKN
C25	HT_REFCLKP
C3	GFX_TX2P
C4	GFX_RX0N
C6	VDDPCIE
C8	AUX_CAL
D1	GFX_TX3P
D10	HPD
D11	VSS
D12	SUS_STAT#
D13	TESTMODE
D14	PLLVD18
D15	VSSLT
D16	TXCLK_UP
D17	TXCLK_UN
D18	TXOUT_U3P
D19	TXOUT_U3N
D2	GFX_TX3N
D20	TXOUT_U2P
D21	TXOUT_U2N
D22	VDDHTRX
D23	VSSAHT
D24	HT_TXCAD0P
D25	HT_TXCAD0N
D3	VSSAPCIE
D4	GFX_RX0P
D5	VSSAPCIE
D6	VDDPCIE
D7	VDDA18PCIEPLL
D8	SYSRESET#
D9	TMDS_HPD
E1	GFX_TX4N
E11	REFCLK_P
E12	AVDD
E14	VSS
E15	VSS
E17	RESERVED
E18	GREEN
E19	BLUE
E2	GFX_TX4P
E20	VSSLT
E21	VDDHTRX
E22	VSSAHT
E24	HT_TXCAD1P

Ball Ref	Pin Name
E25	HT_TXCAD1N
E4	VSSAPCIE
E5	GFX_RX3P
E6	VDDPCIE
E7	VDDA18PCIEPLL
E8	DAC_SDA
E9	GPIO3
F1	GFX_TX6P
F11	REFCLK_N
F12	AVDD
F14	AVDDDI
F15	RESERVED
F17	RESERVED
F18	GREEN#
F19	BLUE#
F2	GFX_TX6N
F20	VDDHTRX
F21	HT_TXCAD8P
F22	HT_TXCAD3N
F23	HT_TXCAD3P
F24	HT_TXCAD2P
F25	HT_TXCAD2N
F3	GFX_TX5N
F4	GFX_TX5P
F5	GFX_RX3N
F6	VDDPCIE
F7	GPIO2
F8	DAC_SCL
F9	VDD18
G1	VSSAPCIE
G11	RESERVED
G12	GPIO4
G14	DAC_RSET
G15	AVSSDI
G17	RED#
G18	RED
G19	VDDHTRX
G2	VSSAPCIE
G20	HT_TXCAD9P
G21	HT_TXCAD8N
G22	VSSAHT
G24	VSSAHT
G25	VSSAHT
G4	VSSAPCIE

Ball Ref	Pin Name
G5	GFX_RX4P
G6	GFX_RX4N
G7	VDDPCIE
G8	VSS
G9	VDD18
H1	GFX_TX8P
H11	VDD33
H12	VDD33
H14	AVSSQ
H15	AVDDQ
H17	VDDA18HTPLL
H18	VDDHTRX
H19	VSSAHT
H2	GFX_TX8N
H20	VSSAHT
H21	HT_TXCAD9N
H22	HT_TXCAD4N
H23	HT_TXCAD4P
H24	HT_TXCLK0P
H25	HT_TXCLK0N
H3	GFX_TX7N
H4	GFX_TX7P
H5	GFX_RX5P
H6	GFX_RX5N
H7	VSSAPCIE
H8	VDDPCIE
H9	VDDA18PCIE
J1	GFX_TX9N
J10	VDDA18PCIE
J11	VDDC
J12	VSS
J14	VDDC
J15	VSS
J16	VDDC
J17	VDDHT
J18	HT_TXCAD11P
J19	HT_TXCAD12N
J2	GFX_TX9P
J20	HT_TXCAD10P
J21	HT_TXCAD10N
J22	VSSAHT
J24	HT_TXCAD5N
J25	HT_TXCAD5P
J4	VSSAPCIE

Ball Ref	Pin Name
J5	GFX_RX6N
J6	GFX_RX6P
J7	GFX_RX7P
J8	GFX_RX7N
J9	VDDPCIE
K1	GFX_TX11P
K10	VDDA18PCIE
K11	VSS
K12	VDDC
K14	VSS
K15	VDDC
K16	VDDHT
K17	HT_TXCAD11N
K2	GFX_TX11N
K22	HT_TXCAD7N
K23	HT_TXCAD7P
K24	HT_TXCAD6P
K25	HT_TXCAD6N
K3	GFX_TX10N
K4	GFX_TX10P
K9	VDDPCIE
L1	VSSAPCIE
L10	VDDA18PCIE
L11	VDDC
L12	VSS
L14	VDDC
L15	VSS
L16	VDDHT
L17	VSSAHT
L18	HT_TXCAD13N
L19	HT_TXCAD12P
L2	VSSAPCIE
L20	HT_TXCLK1N
L21	HT_TXCLK1P
L22	VSSAHT
L24	VSSAHT
L25	VSSAHT
L4	VSSAPCIE
L5	GFX_RX8P
L6	GFX_RX8N
L7	VSSAPCIE
L8	GFX_RX9N
L9	VDDPCIE
M1	GFX_TX13P

Ball Ref	Pin Name
M10	VDDA18PCIE
M11	VSS
M12	VDDC
M13	VDDC
M14	VSS
M15	VDDC
M16	VDDHT
M17	VDDHTTX
M18	HT_TXCAD15N
M19	HT_TXCAD13P
M2	GFX_TX13N
M20	VSSAHT
M21	HT_TXCAD14P
M22	HT_RXCTL0P
M23	HT_RXCTL0N
M24	HT_TXCTL0P
M25	HT_TXCTL0N
M3	GFX_TX12N
M4	GFX_TX12P
M5	GFX_RX11N
M6	VSSAPCIE
M7	GFX_RX10N
M8	GFX_RX9P
M9	VDDPCIE
N1	GFX_TX14N
N12	VDDC
N13	VSS
N14	VDDC
N2	GFX_TX14P
N22	VSSAHT
N24	HT_RXCAD7P
N25	HT_RXCAD7N
N4	VSSAPCIE
P1	GFX_TX15P
P10	VDDA18PCIE
P11	VDDC
P12	VSS
P13	VDDC
P14	VDDC
P15	VSS
P16	VDDHT
P17	VDDHTTX
P18	HT_TXCAD15P
P19	HT_TXCTL1P

Ball Ref	Pin Name
P2	GFX_TX15N
P20	VSSAHT
P21	HT_TXCAD14N
P22	HT_RXCAD5P
P23	HT_RXCAD5N
P24	HT_RXCAD6N
P25	HT_RXCAD6P
P3	GFX_RX14N
P4	GFX_RX14P
P5	GFX_RX11P
P6	VSSAPCIE
P7	GFX_RX10P
P8	GFX_RX12N
P9	VDDPCIE
R1	VSSAPCIE
R10	VDDA18PCIE
R11	VSS
R12	VDDC
R14	VSS
R15	VDDC
R16	VDDHT
R17	VDDHTTX
R18	HT_TXCTL1N
R19	VSSAHT
R2	VSSAPCIE
R20	HT_RXCTL1N
R21	HT_RXCTL1P
R22	VSSAHT
R24	VSSAHT
R25	VSSAHT
R4	VSSAPCIE
R5	GFX_RX13N
R6	GFX_RX13P
R7	VSSAPCIE
R8	GFX_RX12P
R9	VDDPCIE
T1	GFX_REFCLKN
T10	VDDA18PCIE
T11	VDDC
T12	VSS
T14	VDDC
T15	VDDC
T16	VDDHT
T17	VDDHTTX

Ball Ref	Pin Name
T2	GFX_REFCLKP
T22	HT_RXCLK0P
T23	HT_RXCLK0N
T24	HT_RXCAD4N
T25	HT_RXCAD4P
T3	GFX_RX15N
T4	GFX_RX15P
T9	VDDPCIE
U1	GPP_REFCLKP
U10	VDDA18PCIE
U11	VSS
U12	VDDC
U14	VSS
U15	VSS
U16	VDDC
U17	VDDHTTX
U18	HT_RXCAD15N
U19	HT_RXCAD15P
U2	GPP_REFCLKN
U20	HT_RXCAD14P
U21	HT_RXCAD14N
U22	VSSAHT
U24	HT_RXCAD3P
U25	HT_RXCAD3N
U4	VSSAPCIE
U5	GPP_RX4P
U6	GPP_RX4N
U7	GPP_RX5N
U8	GPP_RX5P
U9	VDDPCIE
V1	GPP_TX5P
V11	MEM_A2
V12	VSS
V14	MEM_ODT
V15	MEM_CK_P
V17	MEM_DQ4
V18	VDDHTTX
V19	VSSAHT
V2	GPP_TX5N
V20	HT_RXCAD13N
V21	HT_RXCAD13P
V22	HT_RXCAD1P
V23	HT_RXCAD1N
V24	HT_RXCAD2N

Ball Ref	Pin Name
V25	HT_RXCAD2P
V3	GPPSB_REFCLKN
V4	GPPSB_REFCLKP
V5	GPP_RX3P
V6	VSSAPCIE
V7	VSSAPCIE
V8	VSSAPCIE
V9	VDDPCIE
W1	VSSAPCIE
W11	VSS
W12	MEM_RAS#
W14	MEM_CKN
W15	VSS
W17	MEM_DM0
W18	MEM_DQS0N
W19	VDDHTTX
W2	VSSAPCIE
W20	HT_RXCAD12N
W21	HT_RXCAD12P
W22	VSSAHT
W24	VSSAHT
W25	VSSAHT
W4	VSSAPCIE
W5	SB_RX3P
W6	GPP_RX3N
W7	VSSAPCIE
W8	VSSAPCIE
W9	VDDA18PCIE
Y1	GPP_TX3P
Y11	VDD_MEM
Y12	MEM_CAS#
Y14	MEM_A13
Y15	MEM_DQ7
Y17	MEM_DQS0P
Y18	VSS
Y19	MEM_DQ3
Y2	GPP_TX3N
Y20	VDDHTTX
Y21	VSSAHT
Y22	HT_RXCAD11P
Y23	HT_RXCAD11N
Y24	HT_RXCAD0N
Y25	HT_RXCAD0P
Y3	GPP_TX4N

Ball Ref	Pin Name
Y4	GPP_TX4P
Y5	SB_RX3N
Y6	VSSAPCIE
Y7	SB_RX1N
Y8	SB_RX0N
Y9	VDDA18PCIE

## A.2 RS880D Pin List Sorted by Pin Name

Table A-2 RS880D Pin List Sorted by Pin Name

Pin Name	Ball Ref	Pin Name	Ball Ref	Pin Name	Ball Ref
ALLOW_LDTSTOP	C12	GFX_RX4N	G6	GFX_TX9N	J1
AUX_CAL	C8	GFX_RX4P	G5	GFX_TX9P	J2
AVDD	E12	GFX_RX5N	H6	GPIO2	F7
AVDD	F12	GFX_RX5P	H5	GPIO3	E9
AVDDDI	F14	GFX_RX6N	J5	GPIO4	G12
AVDDQ	H15	GFX_RX6P	J6	GPP_REFCLKN	U2
AVSSDI	G15	GFX_RX7N	J8	GPP_REFCLKP	U1
AVSSQ	H14	GFX_RX7P	J7	GPP_RX0N	AD4
BLUE	E19	GFX_RX8N	L6	GPP_RX0P	AE3
BLUE#	F19	GFX_RX8P	L5	GPP_RX1N	AD3
DAC_HSYNC	A11	GFX_RX9N	L8	GPP_RX1P	AE2
DAC_RSET	G14	GFX_RX9P	M8	GPP_RX2N	AD2
DAC_SCL	F8	GFX_TX0N	B5	GPP_RX2P	AD1
DAC_SDA	E8	GFX_TX0P	A5	GPP_RX3N	W6
DAC_VSYNC	B11	GFX_TX10N	K3	GPP_RX3P	V5
DDC_CLK0/AUX0P	A8	GFX_TX10P	K4	GPP_RX4N	U6
DDC_CLK1/AUX1P	B7	GFX_TX11N	K2	GPP_RX4P	U5
DDC_DATA0/AUX0N	B8	GFX_TX11P	K1	GPP_RX5N	U7
DDC_DATA1/AUX1N	A7	GFX_TX12N	M3	GPP_RX5P	U8
GFX_REFCLKN	T1	GFX_TX12P	M4	GPP_TX0N	AC2
GFX_REFCLKP	T2	GFX_TX13N	M2	GPP_TX0P	AC1
GFX_RX0N	C4	GFX_TX13P	M1	GPP_TX1N	AB3
GFX_RX0P	D4	GFX_TX14N	N1	GPP_TX1P	AB4
GFX_RX10N	M7	GFX_TX14P	N2	GPP_TX2N	AA1
GFX_RX10P	P7	GFX_TX15N	P2	GPP_TX2P	AA2
GFX_RX11N	M5	GFX_TX15P	P1	GPP_TX3N	Y2
GFX_RX11P	P5	GFX_TX1N	B4	GPP_TX3P	Y1
GFX_RX12N	P8	GFX_TX1P	A4	GPP_TX4N	Y3
GFX_RX12P	R8	GFX_TX2N	B2	GPP_TX4P	Y4
GFX_RX13N	R5	GFX_TX2P	C3	GPP_TX5N	V2
GFX_RX13P	R6	GFX_TX3N	D2	GPP_TX5P	V1
GFX_RX14N	P3	GFX_TX3P	D1	GPPSB_REFCLKN	V3
GFX_RX14P	P4	GFX_TX4N	E1	GPPSB_REFCLKP	V4
GFX_RX15N	T3	GFX_TX4P	E2	GREEN	E18
GFX_RX15P	T4	GFX_TX5N	F3	GREEN#	F18
GFX_RX1N	B3	GFX_TX5P	F4	HPD	D10
GFX_RX1P	A3	GFX_TX6N	F2	HT_REFCLKN	C24
GFX_RX2N	C1	GFX_TX6P	F1	HT_REFCLKP	C25
GFX_RX2P	C2	GFX_TX7N	H3	HT_RXCAD0N	Y24
GFX_RX3N	F5	GFX_TX7P	H4	HT_RXCAD0P	Y25
GFX_RX3P	E5	GFX_TX8N	H2	HT_RXCAD10N	AA25
		GFX_TX8P	H1	HT_RXCAD10P	AA24

Pin Name	Ball Ref
HT_RXCAD11N	Y23
HT_RXCAD11P	Y22
HT_RXCAD12N	W20
HT_RXCAD12P	W21
HT_RXCAD13N	V20
HT_RXCAD13P	V21
HT_RXCAD14N	U21
HT_RXCAD14P	U20
HT_RXCAD15N	U18
HT_RXCAD15P	U19
HT_RXCAD1N	V23
HT_RXCAD1P	V22
HT_RXCAD2N	V24
HT_RXCAD2P	V25
HT_RXCAD3N	U25
HT_RXCAD3P	U24
HT_RXCAD4N	T24
HT_RXCAD4P	T25
HT_RXCAD5N	P23
HT_RXCAD5P	P22
HT_RXCAD6N	P24
HT_RXCAD6P	P25
HT_RXCAD7N	N25
HT_RXCAD7P	N24
HT_RXCAD8N	AC25
HT_RXCAD8P	AC24
HT_RXCAD9N	AB24
HT_RXCAD9P	AB25
HT_RXCALN	A24
HT_RXCALP	C23
HT_RXCLK0N	T23
HT_RXCLK0P	T22
HT_RXCLK1N	AA22
HT_RXCLK1P	AB23
HT_RXCTL0N	M23
HT_RXCTL0P	M22
HT_RXCTL1N	R20
HT_RXCTL1P	R21
HT_TXCAD0N	D25
HT_TXCAD0P	D24
HT_TXCAD10N	J21
HT_TXCAD10P	J20
HT_TXCAD11N	K17
HT_TXCAD11P	J18

Pin Name	Ball Ref
HT_TXCAD12N	J19
HT_TXCAD12P	L19
HT_TXCAD13N	L18
HT_TXCAD13P	M19
HT_TXCAD14N	P21
HT_TXCAD14P	M21
HT_TXCAD15N	M18
HT_TXCAD15P	P18
HT_TXCAD1N	E25
HT_TXCAD1P	E24
HT_TXCAD2N	F25
HT_TXCAD2P	F24
HT_TXCAD3N	F22
HT_TXCAD3P	F23
HT_TXCAD4N	H22
HT_TXCAD4P	H23
HT_TXCAD5N	J24
HT_TXCAD5P	J25
HT_TXCAD6N	K25
HT_TXCAD6P	K24
HT_TXCAD7N	K22
HT_TXCAD7P	K23
HT_TXCAD8N	G21
HT_TXCAD8P	F21
HT_TXCAD9N	H21
HT_TXCAD9P	G20
HT_TXCALN	B25
HT_TXCALP	B24
HT_TXCLK0N	H25
HT_TXCLK0P	H24
HT_TXCLK1N	L20
HT_TXCLK1P	L21
HT_TXCTL0N	M25
HT_TXCTL0P	M24
HT_TXCTL1N	R18
HT_TXCTL1P	P19
I2C_CLK	B9
I2C_DATA	A9
IOPLLVD	AE24
IOPLLVD18	AE23
IOPLLVSS	AD23
LDTSTOP#	C10
MEM_A0	AB12
MEM_A1	AE16

Pin Name	Ball Ref
MEM_A10	AC16
MEM_A11	AE13
MEM_A12	AC14
MEM_A13	Y14
MEM_A2	V11
MEM_A3	AE15
MEM_A4	AA12
MEM_A5	AB16
MEM_A6	AB14
MEM_A7	AD14
MEM_A8	AD13
MEM_A9	AD15
MEM_BA0	AD16
MEM_BA1	AE17
MEM_BA2	AD17
MEM_CAS#	Y12
MEM_CKE	AB18
MEM_CKN	W14
MEM_CKP	V15
MEM_COMPN	AD12
MEM_COMPP	AE12
MEM_CS#	AB13
MEM_DM0	W17
MEM_DM1	AE19
MEM_DQ0	AA18
MEM_DQ1	AA20
MEM_DQ10	AE22
MEM_DQ11	AC18
MEM_DQ12	AB20
MEM_DQ13	AD22
MEM_DQ14	AC22
MEM_DQ15	AD21
MEM_DQ2	AA19
MEM_DQ3	Y19
MEM_DQ4	V17
MEM_DQ5	AA17
MEM_DQ6	AA15
MEM_DQ7	Y15
MEM_DQ8	AC20
MEM_DQ9	AD19
MEM_DQS0N	W18
MEM_DQS0P	Y17
MEM_DQS1N	AE21
MEM_DQS1P	AD20

Pin Name	Ball Ref
MEM_ODT	V14
MEM_RAS#	W12
MEM_VREF	AE18
MEM_WE#	AD18
PCE_CALRN	AB8
PCE_CALRP	AC8
PLLVDD	A12
PLLVDD18	D14
PLLVSS	B12
POWERGOOD	A10
RED	G18
RED#	G17
REFCLK_N	F11
REFCLK_P	E11
RESERVED	E17
RESERVED	F15
RESERVED	F17
RESERVED	G11
SB_RX0N	Y8
SB_RX0P	AA8
SB_RX1N	Y7
SB_RX1P	AA7
SB_RX2N	AA6
SB_RX2P	AA5
SB_RX3N	Y5
SB_RX3P	W5
SB_TX0N	AE7
SB_TX0P	AD7
SB_TX1N	AD6
SB_TX1P	AE6
SB_TX2N	AC6
SB_TX2P	AB6
SB_TX3N	AE5
SB_TX3P	AD5
STRP_DATA	B10
SUS_STAT#	D12
SYSRESET#	D8
TESTMODE	D13
THERMALDIODE_N	AD8
THERMALDIODE_P	AE8
TMDS_HPD	D9
TXCLK_LN	A16
TXCLK_LP	B16
TXCLK_UN	D17

Pin Name	Ball Ref
TXCLK_UP	D16
TXOUT_L0N	B22
TXOUT_L0P	A22
TXOUT_L1N	B21
TXOUT_L1P	A21
TXOUT_L2N	A20
TXOUT_L2P	B20
TXOUT_L3N	B19
TXOUT_L3P	A19
TXOUT_U0N	A18
TXOUT_U0P	B18
TXOUT_U1N	B17
TXOUT_U1P	A17
TXOUT_U2N	D21
TXOUT_U2P	D20
TXOUT_U3N	D19
TXOUT_U3P	D18
VDD_MEM	AA11
VDD_MEM	AB10
VDD_MEM	AC10
VDD_MEM	AD10
VDD_MEM	AE10
VDD_MEM	Y11
VDD18	F9
VDD18	G9
VDD18_MEM	AD11
VDD18_MEM	AE11
VDD33	H11
VDD33	H12
VDDA18HTPLL	H17
VDDA18PCIE	AA9
VDDA18PCIE	AB9
VDDA18PCIE	AD9
VDDA18PCIE	AE9
VDDA18PCIE	H9
VDDA18PCIE	J10
VDDA18PCIE	K10
VDDA18PCIE	L10
VDDA18PCIE	M10
VDDA18PCIE	P10
VDDA18PCIE	R10
VDDA18PCIE	T10
VDDA18PCIE	U10
VDDA18PCIE	W9

Pin Name	Ball Ref
VDDA18PCIE	Y9
VDDA18PCIEPLL	D7
VDDA18PCIEPLL	E7
VDDC	J11
VDDC	J14
VDDC	J16
VDDC	K12
VDDC	K15
VDDC	L11
VDDC	L14
VDDC	M12
VDDC	M13
VDDC	M15
VDDC	N12
VDDC	N14
VDDC	P11
VDDC	P13
VDDC	P14
VDDC	R12
VDDC	R15
VDDC	T11
VDDC	T14
VDDC	T15
VDDC	U12
VDDC	U16
VDDHT	J17
VDDHT	K16
VDDHT	L16
VDDHT	M16
VDDHT	P16
VDDHT	R16
VDDHT	T16
VDDHTRX	A23
VDDHTRX	B23
VDDHTRX	D22
VDDHTRX	E21
VDDHTRX	F20
VDDHTRX	G19
VDDHTRX	H18
VDDHTTX	AA21
VDDHTTX	AB22
VDDHTTX	AC23
VDDHTTX	AD24
VDDHTTX	AE25

Pin Name	Ball Ref
VDDHTTX	M17
VDDHTTX	P17
VDDHTTX	R17
VDDHTTX	T17
VDDHTTX	U17
VDDHTTX	V18
VDDHTTX	W19
VDDHTTX	Y20
VDDL18	A15
VDDL18	B15
VDDL33	A14
VDDL33	B14
VDDLTP18	A13
VDDPCIE	A6
VDDPCIE	B6
VDDPCIE	C6
VDDPCIE	D6
VDDPCIE	E6
VDDPCIE	F6
VDDPCIE	G7
VDDPCIE	H8
VDDPCIE	J9
VDDPCIE	K9
VDDPCIE	L9
VDDPCIE	M9
VDDPCIE	P9
VDDPCIE	R9
VDDPCIE	T9
VDDPCIE	U9
VDDPCIE	V9
VSS	AA14
VSS	AB11
VSS	AB15
VSS	AB17
VSS	AB19
VSS	AB21
VSS	AC12
VSS	AE14
VSS	AE20
VSS	D11
VSS	E14
VSS	E15
VSS	G8
VSS	J12

Pin Name	Ball Ref
VSS	J15
VSS	K11
VSS	K14
VSS	L12
VSS	L15
VSS	M11
VSS	M14
VSS	N13
VSS	P12
VSS	P15
VSS	R11
VSS	R14
VSS	T12
VSS	U11
VSS	U14
VSS	U15
VSS	V12
VSS	W11
VSS	W15
VSS	Y18
VSSAHT	A25
VSSAHT	AD25
VSSAHT	D23
VSSAHT	E22
VSSAHT	G22
VSSAHT	G24
VSSAHT	G25
VSSAHT	H19
VSSAHT	H20
VSSAHT	J22
VSSAHT	L17
VSSAHT	L22
VSSAHT	L24
VSSAHT	L25
VSSAHT	M20
VSSAHT	N22
VSSAHT	P20
VSSAHT	R19
VSSAHT	R22
VSSAHT	R24
VSSAHT	R25
VSSAHT	U22
VSSAHT	V19
VSSAHT	W22

Pin Name	Ball Ref
VSSAHT	W24
VSSAHT	W25
VSSAHT	Y21
VSSAPCIE	A2
VSSAPCIE	AA4
VSSAPCIE	AB1
VSSAPCIE	AB2
VSSAPCIE	AB5
VSSAPCIE	AB7
VSSAPCIE	AC3
VSSAPCIE	AC4
VSSAPCIE	AE1
VSSAPCIE	AE4
VSSAPCIE	B1
VSSAPCIE	D3
VSSAPCIE	D5
VSSAPCIE	E4
VSSAPCIE	G1
VSSAPCIE	G2
VSSAPCIE	G4
VSSAPCIE	H7
VSSAPCIE	J4
VSSAPCIE	L1
VSSAPCIE	L2
VSSAPCIE	L4
VSSAPCIE	L7
VSSAPCIE	M6
VSSAPCIE	N4
VSSAPCIE	P6
VSSAPCIE	R1
VSSAPCIE	R2
VSSAPCIE	R4
VSSAPCIE	R7
VSSAPCIE	U4
VSSAPCIE	V6
VSSAPCIE	V7
VSSAPCIE	V8
VSSAPCIE	W1
VSSAPCIE	W2
VSSAPCIE	W4
VSSAPCIE	W7
VSSAPCIE	W8
VSSAPCIE	Y6
VSSLT	C14

Pin Name	Ball Ref
VSSLT	C16
VSSLT	C18
VSSLT	C20
VSSLT	C22
VSSLT	D15
VSSLT	E20
VSSLTP18	B13

This page is left blank intentionally.

---

# Appendix B

## *Revision History*

---

### **Rev. 1.30 (Nov 2010)**

- First release of the public version.
- Changes from the last NDA release:
  - Updated Section 2.2.2, “DDR3 Memory Interface”: Clarified on features and limitations of the RS880D memory controller.
  - Updated Table 3-2, “Side-Port Memory Interface”: Revised descriptions for MEM\_DQS[1:0]P/N and MEM\_COMPP/N.
  - Updated Table 5-3, “DC Characteristics for DDC Signals (DDC Mode)”: Revised VILdc and VIHdc values and removed VILac and VIHac values.

This page intentionally left blank.