



Small Arms Training

Volume I, Pamphlet No. 6

Anti-Aircraft

1937

Crown Copyright Reserved

LONDON

PUBLISHED BY HIS MAJESTY'S STATIONERY OFFICE

To be purchased directly from H.M. STATIONERY OFFICE at the following addresses:

Adastral House, Kingsway, London, W.C.2; 120 George Street, Edinburgh 2;

26 York Street, Manchester 1; 1 St. Andrew's Crescent, Cardiff;

80 Chichester Street, Belfast;

or through any bookseller

1937

Price 4d. net



Small Arms Training

Volume I, Pamphlet No. 6

Anti-Aircraft

1937

Crown Copyright Reserved

LONDON

PUBLISHED BY HIS MAJESTY'S STATIONERY OFFICE

To be purchased directly from H.M. STATIONERY OFFICE at the following addresses:
Adastral House, Kingsway, London, W.C.2; 120 George Street, Edinburgh 2;
26 York Street, Manchester 1; 1 St. Andrew's Crescent, Cardiff;
80 Chichester Street, Belfast;
or through any bookseller

1937

Price 4d. net

By Command of the Army Council,

H. G. Creedy

THE WAR OFFICE,
31st March, 1937.

CONTENTS

General :—	PAGE
Introductory	5
Principles of small arms defence	6
Protection	6
Warning and air sentries	7
Ranging	8
Recognition	8
Considerations in training	9
Lesson 1. Précis of introductory lecture	11
„ 2. Direct attacker (Rifle)	12
„ 3. Direct attacker (Rifle—Spotlight)	15
„ 4. The lead (Rifle)	16
„ 5. Crossing aeroplane (Rifle)	18
„ 6. Crossing aeroplane (Rifle—Spotlight)	19
„ 7. Fire discipline training	20
„ 8. Direct attacker (Light machine gun—Spotlight)	22
„ 9. Crossing aeroplane (Light machine gun—Spotlight)	23
„ 10. Anti-aircraft handling (Light machine gun)	27
Appendix I.—Apparatus and accessories—	
Silhouette model diagrams	30
12-degree lead measurement	30
Model aeroplane with pole and stand	32
Spotlight projector	33
Moving target for spotlight projector	38

GENERAL

Introductory

1. The principles of protection against aircraft are contained in Field Service Regulations, Vol. II, 1935, Sec. 38, and Infantry Training, 1937, Sec. 55.

2. So far as troops are concerned, probably the most vulnerable target that presents itself to aircraft is that of a column on the line of march, but all conditions must receive due consideration. Attacks may be made either by bomber aircraft from altitudes at which small arms fire is ineffective, *i.e.* over 2,000 feet, or by fighter and bomber aircraft flying low, when the main defence is small arms fire.

In the former case there will usually be some warning owing to the height at which the aircraft fly, although in cloudy weather such warning will be reduced.

In the latter case, owing to the risk from small arms fire the aircraft will seek to effect surprise. They may, therefore, use clouds, low hills, woods, etc., for concealment and by attacking out of the sun will endeavour to put the anti-aircraft defence on the ground at a disadvantage.

3. Instructions contained in this chapter are concerned only with low-flying attacks, *i.e.* attacks made at a range of 600 yards or under. These attacks will be made at high speed, probably between 200 to 300 m.p.h., and so will be quickly ended. They may be repeated at short intervals; usually a combination of light bombs and machine-gun fire will be employed. In the case of two-seater aircraft the rear machine guns may also be brought to bear as the aircraft is climbing and turning away.

On occasions the attack may be purely by gas spray, in which case the aircraft is likely to fly straight over, or low and parallel to, the column on an even keel in accordance with the direction of the wind.

Attacks may be made either individually by aircraft flying along a column and diving in succession or by a simultaneous converging attack by several aircraft from different directions. With the first method little or no warning can be expected beyond possibly the noise of bombs exploding or of fire from other troops which are being attacked. With the second

some warning should be forthcoming, as the aircraft must first get into a definite formation above their target.

Against undisciplined or demoralized troops air attacks may have a decisive effect.

Enemy reconnaissance aeroplanes searching for information are sometimes forced to fly low. Small arms anti-aircraft fire is of great value to prevent them achieving their object.

Principles of small arms defence

4. The following are the main principles to be observed :—
 - i. There must be a system whereby warning of the approach of hostile aircraft is conveyed to the troops (*see* para. 6 below).
 - ii. The maximum fire of all available small arms weapons will immediately be brought to bear on the attacking aircraft, provided that they are within range. It is only by adopting an offensive attitude that morale can be maintained and that low-flying attacks by aircraft will be made so costly as to become unsound policy for the enemy.
 - iii. Subject to ii, above, units of all arms will present to the attacking aircraft the least favourable target, according to the situation in which they find themselves.
 - iv. When movement is stopped, it must be continued at the earliest moment.
 - v. When troops are on the move, rifle fire will generally be quicker to produce and, therefore, more suitable.
 - vi. In bivouacs, billets, or when otherwise halted, light machine guns, suitably sited and concealed, should form the main small arms defence.
 - vii. To be effective, fire must be controlled.
 - viii. Speed in opening fire is essential. This requires strict fire discipline training.
 - ix. Fire unit commanders must know beforehand whether they are to open fire on their own initiative or not.

Protection

5. Every commander is responsible for the protection of his command against surprise, and for concealing his dispositions from enemy ground troops and aircraft.

i. **On the move.**—In cases of troops on the march, the time factor precludes, as a normal procedure, the possibility of advance across country and, except in small columns, large spaces between units and sub-units. Columns must, there-

fore, generally be protected by light machine guns piqueting the area and particularly the defiles through which the troops are moving. Other means of protection are light machine guns mounted on M.T. vehicles moving within the column or on the flanks.

The dispersion of small infantry parties throughout a column on the march for protective duties should be resorted to only in most exceptional circumstances or when tactical considerations are of no account.

All units must protect themselves with the weapons at their disposal. The rifle will normally be used, but light machine guns should be brought into action if time permits; it is essential that as great a volume of fire as possible should be speedily produced. Normally, therefore, all available rifles will be fired.

Since there will not be time to issue orders for opening fire through the usual chain of command, responsibility must be delegated. The fire unit will be the platoon. Men will march with magazines charged with ten rounds and sights set at 500 yards.

ii. **When halted.**—The fire of light machine guns is the most economical form of protection. It should be organized in the form of area defence, the guns being sited not less than 50 yards or more than 800 yards apart at the corners of a series of equilateral triangles, disposed so as to cover the area protected. It will sometimes be of advantage to site guns in pairs in order to produce a greater volume of fire in the more likely lines of approach of enemy aircraft. The extent to which this is advisable must depend on the total number of guns available in proportion to the area to be defended. When troops are concealed, orders must be issued whether light machine guns are to be posted and are to open fire against hostile aircraft or not; the opening of fire may betray to the hostile observer the fact that the area is occupied. During short halts anti-aircraft light machine guns will be disposed under company arrangements. During long halts or in camp, billets or bivouacs the anti-aircraft defence will be co-ordinated under brigade and battalion arrangements.

Warning and air sentries

6. The efficiency of the defence will depend firstly on the speed at which warning of the attack can be conveyed to subordinate commanders; secondly on the quickness with which warning can be followed by executive orders for move-

ment or fire, and lastly on the skill, steadiness and fire discipline of the troops.

In certain types of attack and under conditions favourable to the attacking aircraft, there will often be not more than a few seconds warning, even with quick, well-trained air sentries. With well trained and disciplined troops even these few seconds will be valuable.

The number of air sentries to be detailed must depend on circumstances, but should not be less than two for each company. The direction and area in which each sentry is to watch must be carefully regulated. Sentries must continually watch the sky, especially in the direction of the sun, towards low hills, woods, etc.; they must also listen for the approach of aircraft.

At the halt, if time allows, they should be posted on high ground to get a clear view of the horizon. Their attention must be concentrated all the time on the approach of aircraft. The duties will be exhausting and entail great strain on the eyes. Arrangements, therefore, must be made for constant reliefs. Details of warning signals are given in Lesson 7.

Ranging

7. Rifle and light machine gun fire may be taken as effective up to 600 yards. The following is a rough guide as to whether the target is within this range or not:—

At 600 yards the aircraft is almost a silhouette: the national markings may be visible, but the colours are not discernible. At closer ranges such details as the pilot's head, struts and colours of national markings become more clearly defined.

Training will be carried out with the co-operation of aircraft when available, by demonstration flights arranged at a height of 600 yards and at distances over and within that range. Full use will be made of opportunities of ranging on aeroplanes during training.

Recognition

8. Those in constant practice can recognize aircraft by silhouette, or, at closer ranges, by national markings. But, since in peace, practice in recognition of foreign aircraft is not possible, the most that can be aimed at, practically, is to train personnel to recognize our own aircraft. On the outbreak of war, silhouettes and markings of allied aircraft will be issued.

In training, emphasis should be laid on the necessity for trying to distinguish between a friendly aeroplane flying low in order to drop a message and a hostile one diving to attack. But, at the beginning of a campaign, it must be realized that,

in actual fact, any suspicious action by an aeroplane will render it liable to be fired on.

Recognition by silhouette demands a high standard of training, since hostile aircraft will usually present themselves head on, when identification is most difficult. Troops will, therefore, be trained in peace to recognize those types of our own aeroplanes which are most likely to be operating in their neighbourhood.

Recognition by national markings offers the surest means of identification, but such markings are only visible at close range, when an aeroplane is crossing or overhead. National markings consist of signs of different shapes and colours, standardized for each country. These are painted on the wings, body and tail.

Considerations in training

9. Owing to the speed of modern aircraft it is impracticable to provide the ground firer with any form of anti-aircraft sight or other mechanical aid for either the rifle or the light machine gun. Extreme accuracy of fire must, therefore, give way to quick retaliation and volume. Estimation of range can be limited to a knowledge of when fire can usefully be opened.

Training, therefore, will primarily be concentrated on obtaining :—

- i. Speed in opening fire. The time available will depend on early warning.
- ii. Strict fire discipline.
- iii. Maximum volume of controlled fire.

10. The following are the two main types of anti-aircraft target to be considered :—

- i. The direct attacker.
- ii. The crosser.

Of these (i) presents the more urgent problem and will allow of practically no warning. It consists of an aeroplane diving to the attack or climbing away after it. On the march, the rifle is likely to be the most effective means of retaliation against this type of attack, and men must be instructed how to shoot and turn quickly. Light machine guns should also be brought into action, if time permits.

As regards (ii), this type is likely to provide opportunities to both rifle and light machine gun firers. Since no mechanical aid is practicable, the firers will have no assistance other than a "lead" calculated as being 12 degrees when the target is crossing at right angles to the line of fire. They must receive instruction as to how they can instinctively recognize the lead

in the sky. The swing of the weapon is of the utmost importance and it must be impressed on all troops that the movement of the rifle or light machine gun must not be checked at the moment of pressing the trigger.

11. Riflemen and light machine gunners will receive training on identical lines.

12. Officers responsible for training should study carefully the Appendix, page 30, which gives in detail the methods of preparing and setting up all of the apparatus required for teaching lessons in anti-aircraft training.

The spotlight projector should be looked upon as one of the most valuable means of teaching the soldier to aim and fire quickly at aircraft, and use should be made of it throughout the soldier's service. The projector is intended to provide an instructor with a means of checking correctness of aim, judgment of deflection and swing. The light projected takes the place of the bullet, thus adding interest and allowing the individual to see the results of his fire.

13. When units are not exercised in anti-aircraft training with the rifle and are being taught the light machine gun only, the relevant portions of Lessons 1 and 2 will be given before Lesson 8, and Lesson 4 should precede Lesson 9.

LESSON 1.—ANTI-AIRCRAFT DEFENCE

This lesson will be given in the form of a lecture and, whenever possible, illustrated by diagrams. The basis of the lecture will be a summary of the general paras. 1 to 12, and Infantry Training.

Précis of lecture :—

1. Methods of air attack.
2. Principles of small arms defence.
3. Protection and defence against air attack.
4. Warning and air sentries.
5. Ranging and recognition.
6. Considerations in training.

LESSON 2.—DIRECT ATTACKER (RIFLE)

Instructor's Notes

Stores.—

Diagrams of diving and climbing aeroplanes fixed along the top of all four walls of the barrack room or place of parade, so as to allow of the 25 degrees safety angle.

Squad in two ranks, 10 yards or less from the diagrams.

*Order : " Standing "—" Charge magazines " *—" 500 "
—" Rest."*

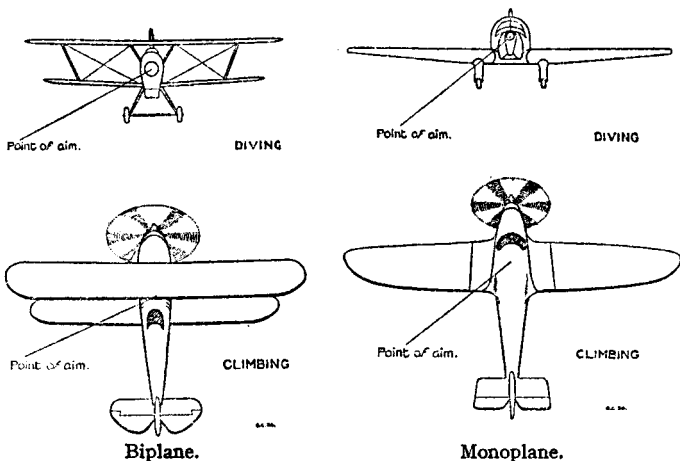

FIG. 1.

1. (i) Explain that, owing to the high speed of modern aircraft, it is essential that fire should be delivered quickly and with reasonable accuracy. This lesson deals with the method of firing at diving and climbing aeroplanes. There are two rules of aiming (*see* Fig. 1):—
 - (a) Sights set at 500.
 - (b) Align the sights on the centre of the aeroplane.
- ii. Demonstrate from the standing position :—
 - Aircraft action.
 - Aircraft front.
 - Firing.
 - Stop.
 - Charge magazines.

* For anti-aircraft purposes magazines will always be charged with 10 rounds.

2. Explain and demonstrate with squad imitating :—

i. **Aircraft action.**—On the order "Aircraft action" adopt the standing load position with the muzzle of the rifle as vertical as possible and load, leaving the safety catch forward.

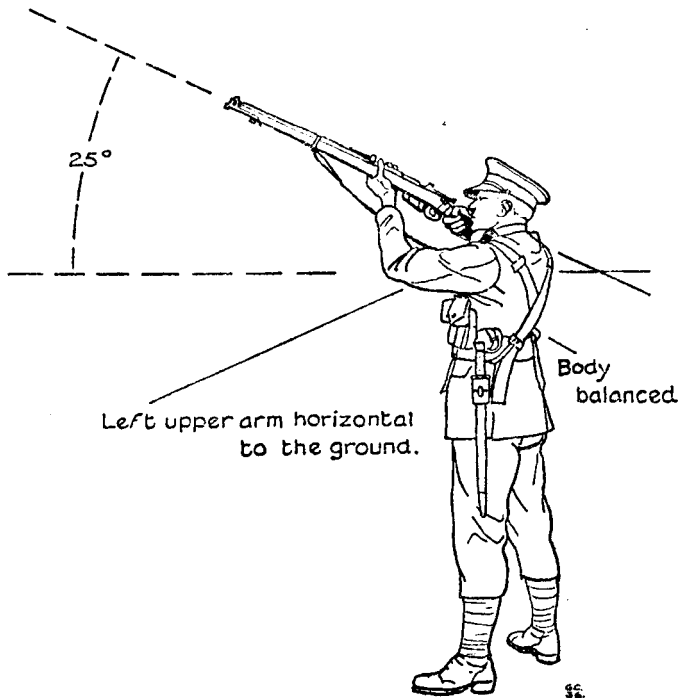

FIG. 2.

ii. **Safety angle.**—The rifle when held in the firing position should be at an angle of not less than 25 degrees with the horizontal. A useful guide is that the upper part of the left arm must be parallel with the ground (see Fig. 2).

iii. Practise squad.

3. Quick aiming and turning.—

- i. Explain that, owing to aircraft being within range for such a short period, it is essential that all movements, such as coming into the aiming position and changing direction, should be carried out with the utmost speed. A standard of firing the first shot within two seconds should be aimed at.
- ii. Explain and demonstrate with detail :—

On the order "Aircraft front," raise the rifle quickly to the aiming position, take first pressure and aim. On a new direction being ordered, turn quickly, pivoting on the right leg, in the direction named and aim. Finally, return to the loading position.
- iii. Practise squad.

4. Firing.

- i. Explain that fire against aircraft will always be at the rapid rate. Before a new target or direction is ordered, the command "Stop" will be given. If a new direction is immediately ordered, the man, without applying the safety catch, will turn quickly and, on the command "Rapid fire," continue to fire as before. When the safety angle cannot be maintained, men will adopt the loading position and load if necessary.
- ii. Practise squad.

LESSON 3.—DIRECT ATTACKER (RIFLE— SPOTLIGHT)

Instructor's Notes

Stores.—

Diagrams of diving and climbing aeroplanes as in Lesson 2.

One rifle fitted with a spotlight projector apparatus with flex and transformer. (See page 33.)

Aiming rest placed in the centre of the room so that diagrams are on all sides and approximately at equal distances from the aiming rest.

Forms or chairs as required.

As proficiency increases, this lesson can be repeated with respirators.

1. Practise each man in firing—by word of command (men should stand close to the aiming rest):—

“Without dummies”: “Standing”—“Charge magazines”—“500”—“Rest”—“Aircraft action”—“Aircraft front”—“Rapid fire”—“Stop”—“Aircraft about”—“Rapid fire”—“Stop”—“Rest.”

On the order “Rest,” men will lower the rifle gently to the ground in order not to disturb the focus and registration of the projector.

Repeat the above as necessary, using targets in all directions, i.e. right, left, front and about, until the men develop quickness in firing and turning. Each man should be given not more than two directions before the order “Rest.”

2. Repeat, using dummies.

LESSON 4—THE LEAD (RIFLE)

Instructor's Notes

Stores—

Model aeroplane with pole and stand fitted with movable arm, rectangle and line-of-flight rod (see Fig. 11). Set up with a sky background.

12 degrees displayed in barracks at 10 yards, 30 yards and 100 yards.

The model aeroplane will be set up as a direct crossing plane with the rectangle a 12 degrees lead in front. Distance from the centre of the stand to the centre of the aiming rest—nine yards.

Place rifles on the aiming rests.

1. Explain that it was necessary to aim off a "lead" in front of moving targets on the ground (Rifle—Lesson 12) and that the same principle will apply in aiming and firing at aircraft crossing the front. A lead of 12 degrees will therefore always be maintained in front of all crossing targets, whatever their direction, except the "direct attacker." The two rules of aiming at crossing aeroplanes are:—

- i. Sights set at 500 yards.
 - ii. Direct the rifle the required lead in front of the aeroplane and in the direction of its flight. Maintain the lead by swinging with the aeroplane and fire without checking the swing.
2. i. Question squad on the method of measuring degrees taught in application of fire (Lesson 7) and explain that each man must measure for himself what part of his left hand when at arm's length will give 12 degrees from the nose of the aeroplane to the centre of the rectangle (see Fig. 3). The parts of the hand which give this measurement at ten yards will also give 12 degrees at any range.
- ii. Practise squad at ten yards measuring the lead in the aircraft action position with the left arm extended.

3. Lower the rectangle. Practise squad aiming off 12 degrees with and without the aid of the hand. Check by the rectangle, which will always be raised at right angles to the firer irrespective of the direction of flight of the plane.

4. i. Explain that all ranks should practise the lead against a sky background and on clouds until the measurement becomes instinctive.

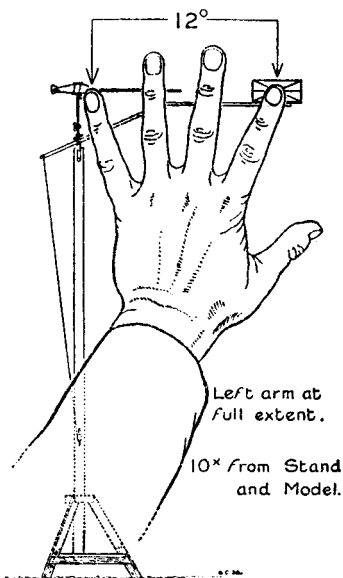

FIG. 3.

- ii. Practise squad at distances of 30 yards and 100 yards which have been previously measured and marked out and provide a sky background. (See Appendix I, Figs. 8, 9, 10.)
5. Practise squad at ranges up to 600 yards.

LESSON 5.—CROSSING AEROPLANE (RIFLE)

Instructor's Notes

Stores.—

Model aeroplane with pole.—The model to be carried by a fatigued man at a brisk pace on the front and flanks of the squad at not more than six yards' distance.

Squad in two ranks.

Order : " Standing "—" Charge magazines," " 500," " Rest."

1. i. Explain that the lesson teaches the use of the " lead " at crossing aeroplanes. Question squad on the two rules of aiming and emphasize the continuance of the swing at the moment of firing. The feet may be moved to suit the swing, but the direction will not be changed.
- ii. Explain and demonstrate with squad standing behind the instructor watching the swing of the rifle—" Aircraft action "—" Aircraft front—" Rapid fire "—" Stop "—" Charge magazines."

2. **Quickening.**—

- i. Explain that, on the order " Aircraft action "—" Aircraft right " (" about," etc.), men will turn quickly in the direction named, aim the rifle the " lead " in front of the aeroplane, take the first pressure and swing along the line of flight.
- ii. Practise changing direction, quick aiming and swing. Commands: " Aircraft action "—" Aircraft front "—" Rest." Order fatigued man to carry the model in a new direction, then order " Aircraft action "—" Aircraft right " (or according to new direction).

3. Practise squad (in two ranks not more than six yards from the model) by word of command.

LESSON 6.—CROSSING AEROPLANE (RIFLE— SPOTLIGHT)

Instructor's Notes

Stores.—

A rifle fitted with a spotlight projector. Model aeroplane. Aiming rest ten yards from the centre of the run of the moving aeroplane. (See pages 33 and 38.) An assistant to work the model aeroplane.

1. i. Explain that the lesson gives further practice in instinctively judging the "lead," aiming and firing at crossing aeroplanes.
- ii. Practise each man in judging the "lead" from a stationary aeroplane by ordering the man to aim at a point which he estimates to be 12 degrees in front of the aeroplane and say "On." Then press the switch and check by means of the position of the spot of light in relation to the nose of the aeroplane. Disturb the rifle after each aim.

2. Aiming and swing.—

Remove rifle from the aiming rest. Each man will be ordered to judge his lead, aim and swing in the direction of flight. Press switch at intervals. At the conclusion of the run discuss the "lead" and "swing."

Order: "Without dummies"—"Standing—Charge magazines—500"—"Rest"—"Aircraft action"—"Aircraft front." (On the command "Aircraft front," the aeroplane will start to move.)

3. Firing.—

"Without dummies"—"Standing—Charge magazine—500"—"Rest"—"Aircraft action"—"Aircraft front"—"Rapid fire."

During firing, stand behind the firer and watch the spot of light in relation to the aeroplane. At the conclusion of firing discuss the lead and swing.

LESSON 7.—FIRE DISCIPLINE TRAINING

Instructor's Notes

Stores.—

Respirators.

This lesson can be carried out in the vicinity of barracks and also during platoon training or on route marches. When no suitable targets are available, the line of flight of an imaginary aeroplane will always be indicated.

Order : " Without dummies " — " Standing — Charge magazines " — " 500 " — " Sling arms. " Respirators in the " alert " position.

Practice will be carried out in the following formations :—

Sections in file on each side of the road.

Marching in threes on one side of the road.

Marching in fours on one side of the road.

1. Explain :—

- i. The platoon or corresponding sub-unit will be the fire unit.
- ii. Platoon serjeants and section leaders will not fire. They will repeat all orders, watch for signals from the fire unit leader, assist in control of fire and watch that men do not fire when their rifles are below the safety angle. Section leaders will place themselves where they can observe signals and control the fire of their men.
- iii. Whenever possible, fire control will be by word of command but, owing to noise, etc., this will at times be difficult and, therefore, signals will also be required. It may be necessary to use the whistle to draw attention to an order about to be given.
- iv. Fire unit leaders should realize that an aeroplane which is climbing away after attack gives a better target than one almost overhead. The order and signal " Stop " — " Aircraft about " — " Rapid fire " should, therefore, be given in plenty of time.
- v. When attacked from the air, during the march, the centre of the road should be avoided and, therefore, the formation which is least vulnerable is that of sections in file on each side of the road. A column when attacked may be moving in " threes " or " fours " ; these formations will therefore also receive consideration.

- vi. Emphasize the speed at which attacks develop and the short time during which aircraft is within range, and question on the types of attack, *i.e.* direct attacker, crossing aeroplane and gas sprayer.
2. Explain that, on receiving warning of an impending air attack, the following procedure will be carried out :—
 - i. Fire unit leader orders : “ No . . . Platoon ”—“ Aircraft action ” and the men act as taught in Lessons 2 and 5.
 - ii. To open fire—fire unit leader orders : “ Aircraft front ”—(“ about,” “ left,” or “ right ” according to the direction of the target) and points at the target—“ Rapid fire.” Men act as taught in Lessons 2 and 5.
 - iii. “ Stop ”—The order and signal (hand waved across the body) will be given before a new target or direction is indicated.
 - iv. “ Charge magazines.” Magazines will not be charged until the attack has definitely ceased. Fire unit leader orders : “ Stop ”—“ Charge magazines.” Men charge magazines as taught and sling arms.
 - v. Practise squad in all formations.
 3. Signals :—
 - i. Question on the duties of air sentries (para. 6, page 7).
 - ii. Explain and demonstrate the following signals :—

Enemy aircraft in sight.—A succession of long blasts on the whistle. Since the signal may often be inaudible, a visual signal will also be used, *viz.* : both arms raised above the head and the hands waved.

Enemy aircraft attack ended.—Two long blasts on the whistle repeated at intervals of five seconds.
 4. Gas sprayer :—

In the event of a gas-spray attack which may necessitate the aircraft flying parallel to the road at a height which makes it impossible to maintain the safety angle while engaging it, only those files on the side of the road nearest the aeroplane will open fire, ignoring the safety angle.

 - i. Fire unit leader orders : “ Gas ”—“ Aircraft action ” and points in the direction of the target. Men act as in Lessons 2 and 5.
 - ii. To fire—Fire unit leader signals by allowing his hand to drop to his side. Men, having adjusted respirators, act as taught in Lessons 2 and 5.
 - iii. “ Stop ”—Fire unit leader signals—hand waved across the body.
 5. Practise squad at the halt in various formations, working on signals.
 6. Practise squad in the complete lesson on the move.

LESSON 8.—DIRECT ATTACKER (L.M.G.— SPOTLIGHT)

Instructor's Notes

Stores.—

Gun fitted with spotlight projector, tripod, magazines, Diagrams of diving and climbing aeroplanes pasted on all four walls of the barrack room or place of parade.

Gun and magazine will be mounted on the tripod which, if possible, should not be more than ten yards from all diagrams.

The projector will be focussed and registered before the lesson. The projector will be adjusted so that the light will appear each time the trigger is pressed (see Appendix). In order not to disturb the registration, the working parts of the light machine gun will be left forward throughout this lesson.

1. Explain that the lesson deals with aiming and firing the light machine gun at diving and climbing aeroplanes. The rules for aiming are similar to those taught in Lesson 2 (Rifle). Question squad on the rules of aiming.

Note.—For units not exercised in the rifle, see para. 13, page 10.

2. Explain and demonstrate:—

- i. On the order "Aircraft front," raise the butt quickly to the shoulder and aim.
- ii. On the order "Rapid fire," fire continuously until the order "Stop" is given or the aeroplane is out of range. Once fire has been opened, observation and correction must be made entirely from the spotlight and all further reference to sights ignored.

3. Practise squad aiming and firing by word of command to include aeroplanes diving and climbing from different directions. Observe the spotlight, and discuss the actions of the firer.

4. Explain that, in engaging aircraft, tracer ammunition may be used and the stream of tracer will be directed at the target in exactly the same way as the spotlight.

LESSON 9.—THE CROSSING AEROPLANE (LIGHT MACHINE GUN—SPOTLIGHT)

Instructor's Notes

Stores.—

Gun with spotlight projector, tripod, magazines, model aeroplane (see Appendix).

Gun, with magazine on, will be mounted on the tripod ten yards from the centre of the run of the moving aeroplane.

Focus and register the projector before the lesson (see Appendix).

1. Practise each man in judging the lead from a stationary model aeroplane. Order the man to aim at a point which he estimates to be 12 degrees in front of the aeroplane and say "On." Then press the switch and check by means of the position of the spot in relation to the nose of the aeroplane.

Note.—For units not exercised in the rifle, see para. 13, page 10.

2. Firing.—

Explain and demonstrate at moving model.

- i. On the order "Aircraft front" raise the butt quickly to the shoulder and direct the gun the lead in front of the aeroplane and swing along the line of flight.
- ii. On the order "Rapid fire," fire continuously. Once fire has been opened, observation must be made entirely from the spotlight and all further reference to the sights ignored.
- iii. Check or increase the swing of the gun according to the observation of the spotlight in its relation to the nose of the aeroplane. Balance the body by moving the feet as required.

3. Practise squad. During the practice watch the spot of light projected when the trigger is pressed, in relation to the nose of the aeroplane and any corrections made by the firer. At the conclusion of firing discuss the firer's actions.

4. Hosepipe fire.*—

Explain with the use of diagrams :—

- i. In this method of engaging aircraft the firer, having set his sights at 500 yards, directs his gun the lead of what he judges to be 12 degrees in front of the aeroplane; and, glancing over his sights to obtain

* Provisional.

elevation, swings along the line of flight and presses the trigger. Once fire is opened, observation must be made entirely from the stream of the tracer at, or near, the target and not in its initial flight. All further reference to the sights should be ignored. The path of the tracer gives the optical illusion of curving in the direction of the target. The object is to

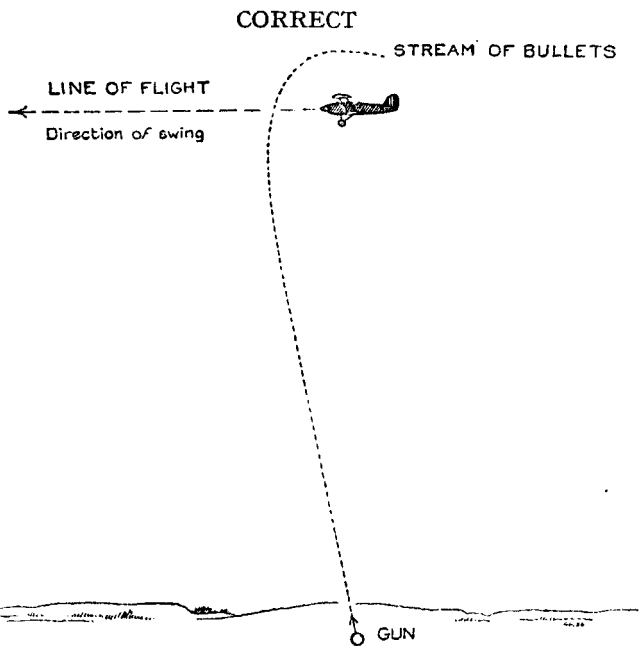

FIG. 4.

place a continuous stream of bullets (much on the same principle as the fireman directs the jet of water from his hose) close in front of the target (*see* Fig. 4), so that the aeroplane appears to be flying into it.

It must be remembered that, when corrections are applied to the gun, the effect of the correction will not be observed until the time of flight of the bullet has elapsed. It has been found that, when once the

stream of bullets has got behind the target, this lag causes a tendency to remain behind. Corrections therefore must be bold so as to be certain of getting ahead of the target.

To obtain observation, the stream of bullets must be continuous. It is essential that the first bullets

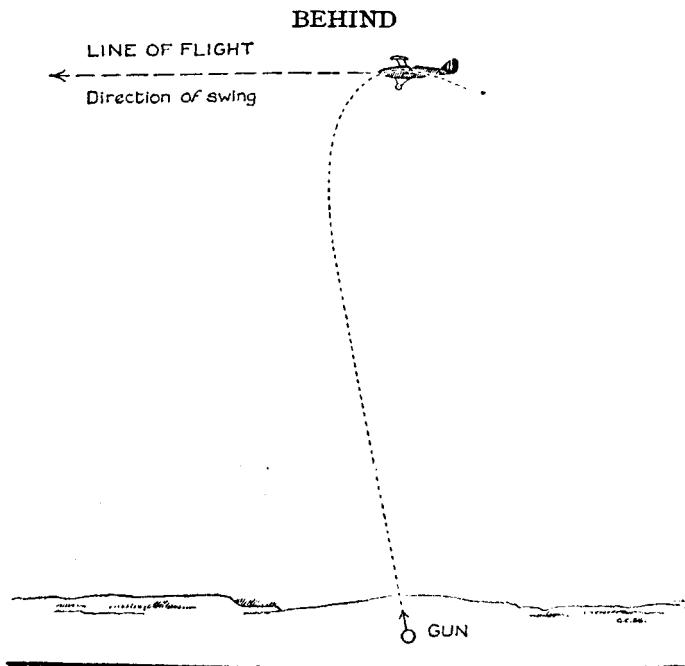

FIG. 5.

of the stream should be in front of the target, owing to the time taken in making corrections. This is especially important for the light machine gun with its small magazine.

- ii. When the path of the tracer is observed to pass across the aeroplane (see Fig. 5), it is an indication that the bullets are passing behind the target and the firer must, at once, boldly swing in front again to obtain his correct lead on the line of flight.

- iii. When the path of the tracer is observed to pass close under the target (see Fig. 6), it is an indication

SHORT

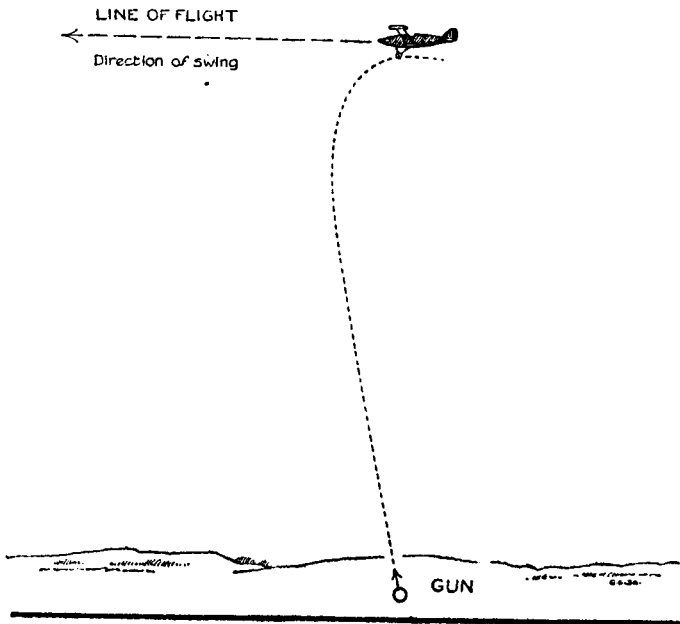

FIG. 6.

that the bullets are short. Action as in 4 (ii) above should again be taken.

LESSON 10.—ANTI-AIRCRAFT HANDLING (LIGHT MACHINE GUN)

Instructor's Notes

Stores.—

Gun, magazines and dummies, magazine box, tripod, model aeroplane on pole.

A fatigued man to carry the model.

As proficiency increases, this lesson can be repeated with respirators.

1. Explain :—

- i. The gun will be mounted for action against aircraft in a position which affords a field of fire over as wide an expanse of sky as possible, at the same time allowing it to be protected and concealed. Gun positions should not be in the open, but under cover or in the shadow of trees, buildings or other cover. It is rarely possible to obtain an all-round view of the sky and maintain concealment. The siting of the guns in an area (*see* para. 5, page 7) must, therefore, be co-ordinated under unit arrangements so that each can watch a portion of the sky. When cover is inadequate, camouflage should be used.
- ii. Care must be taken, in engaging low-flying aircraft, that the gun is not fired in a direction dangerous to our own troops.
- iii. The team required to operate the gun in action against aircraft will consist of three. Their duties will be as follows :—

Section leader.—Select the position for the gun, in accordance with the plan. Direct and control the fire. In normal circumstances the section leader will exercise control by word of command and signal (*see* Lesson 7, Rifle). There will, however, be occasions when No. 1 is operating alone, such as when the gun is mounted on a vehicle. In these circumstances No. 1 will have to select a suitable target and direct and control his own fire.

No. 1.—Fire and maintain the gun in action.

No. 2.—Assist No. 1 to change magazines and keep the gun supplied with ammunition.

The other numbers of the section, *i.e.* Nos. 3, 4, 5 and second in command, will act as riflemen, carrying out protective duties (ground) and ammunition replenishment when required.

iv. The equipment * with the gun during action will be as follows :—

Member of the section (1)	Rifles (2)	L.M.G. on tripod (3)	S.A.A. for rifles (4)	Magazines (5)	Boxes (6)	Remarks (7)
Section leader	1	—	50	—	—	*Tracer filled.
No. 1 ...	—	1	—	—	—	
No. 2 ...	1	—	50	10*	1	
Nos. 3, 4, 5 and 2nd in command	4	—	50	—	—	
			rds. each			

v. Magazines will be filled with tracer and Mk. VII ammunition in the following proportion—3 tracer to 1 Mk. VII.

2. Instructor acting as section leader :—

Select a suitable position for the gun.

Order Nos. 1 and 2 to set up the tripod and mount the gun (light machine gun, Lesson 19).

Point out the field of fire and the position of other guns in the area.

3. Explain the actions of Nos. 1 and 2 on receiving the following orders :—

i. " Aircraft action "—No. 1 will raise the butt strap and put the change lever to " Automatic."

No. 2 will stand on the left of the gun, take a full magazine from the box and hold it in his right hand, ready to " change " when ordered.

ii. " Aircraft front " (right, left, etc.)—No. 1 will turn quickly in the required direction, raising the butt into the shoulder, and aim.

iii. " Rapid fire "—No. 1 will engage the target.

iv. " Stop " and " Go on "—The actions are the same as taught in light machine gun, Lesson 12.

4. Explain and demonstrate the above with one of the squad acting as No. 2 (*see* Fig. 7). (One of the squad will

* The scale of equipment is provisional.

now carry about the model aeroplane to represent a direct attacker or crossing aeroplane.)

New magazine placed on gun
front portion first.

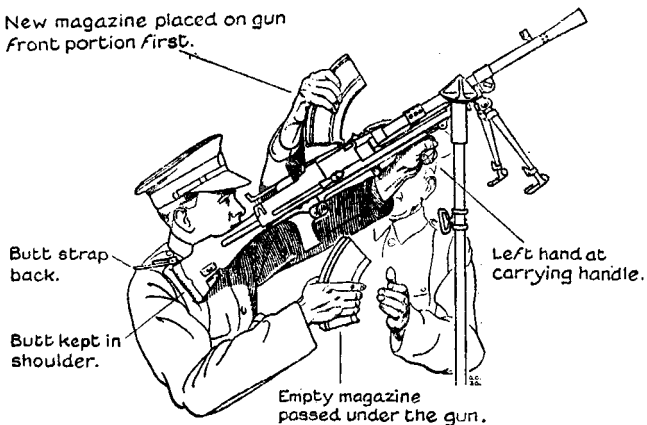

FIG. 7.

5. Practise squad at direct attackers and crossing aeroplanes by word of command and signals (see Lesson 7).

APPENDIX I

APPARATUS AND ACCESSORIES

1. The following equipment is required in connection with anti-aircraft training :—

- i. Silhouette model diagrams of aircraft.
- ii. 12-degree lead measurements.
- iii. Model aeroplane with pole and stand.
- iv. Spotlight projector.
- v. Moving target for use with the spotlight projector.

2. **Silhouette model diagrams.**—Silhouette model diagrams should be affixed to walls of barrack rooms or the places of parade selected for anti-aircraft training. They should be placed at a height which will permit the man under instruction to aim and fire at them while maintaining the safety angle of 25 degrees. The diagrams should all be approximately the same distance from the firer. Diagrams should be mounted on plywood to give a white surround of approximately 9 inches.

3. 12-degree lead measurements.—

i. The lateral distance which 12 degrees subtends at the following distances should be marked on one of the outside walls in barracks as follows (*see* Fig. 8).

Range	Lateral distance
10 yards	6 ft. 8 in.
30 yards	19 ft. 3 in.

A permanent mark should be fixed into the ground at the place from which the distance was measured, *i.e.* 10 yards and 30 yards.

ii. At 100 yards two marks of sufficient height to show the lateral distance, *i.e.* 63 ft. 9 in., against a sky background should be arranged (*see* Fig. 9).

iii. At longer ranges the lateral distance subtended by 12 degrees should be clearly marked by poles on the stop-butt of the classification range or in the vicinity of barracks so as to appear against a sky background (*see* Fig. 10).

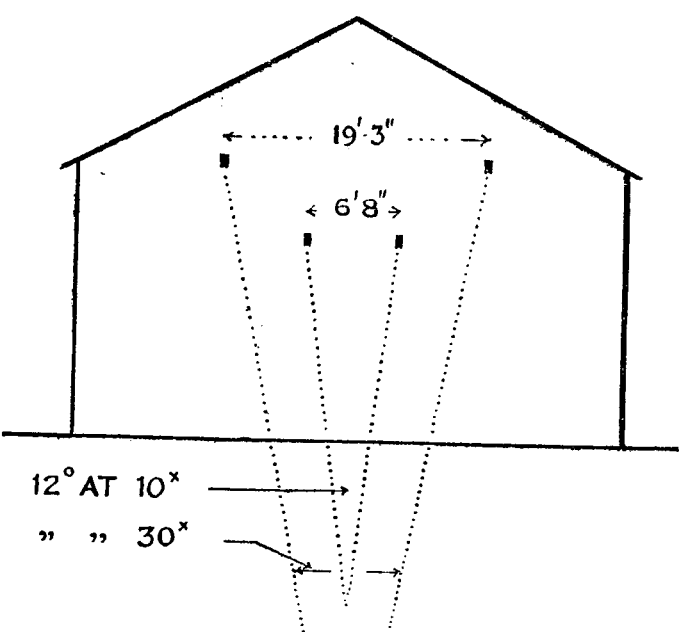

FIG. 8.—12-degree lead marks on wall of building.

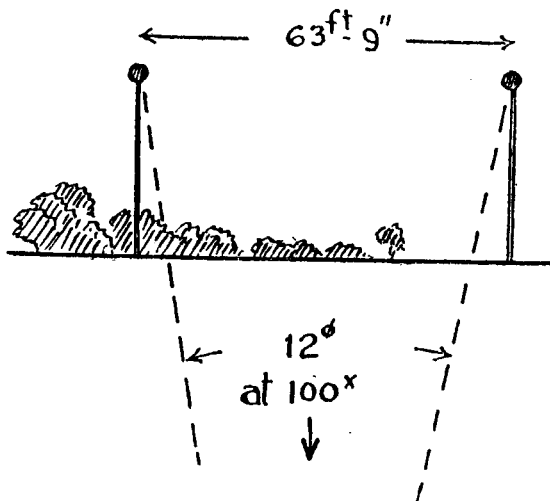

FIG. 9.—12-degree lead marks—sky background.

Place	Range	Lateral distance
Classification range	.. 300 yards	191 feet
or		
Vicinity of Barracks	.. 400 yards	255 feet

12° MEASUREMENT ON A RIFLE RANGE

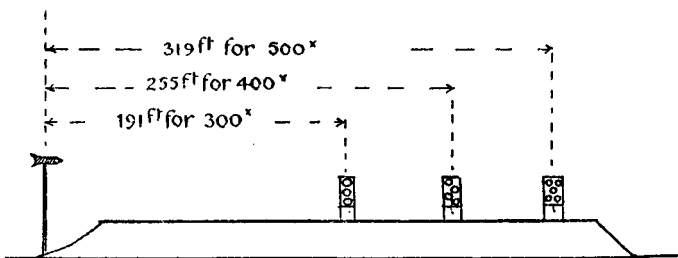

FIG. 10.—12-degree measurements on a rifle range.

4. Model aeroplane with pole and stand.—General description :—

- i. The apparatus consists of a pole, 15 feet high, on which is mounted a small-scale model of an aeroplane and a movable arm carrying a wire rectangle which can be placed so as to appear to be directly in the line of flight of the aeroplane, and at a suitable distance ahead of it to represent the distance through which the aeroplane would travel during the flight of a bullet fired at it. The arm can be lengthened to give 12 degrees at ten yards by adding a bar which can be slipped over the existing movable arm and held in place by two clips (*see* Fig. 11). This small alteration can be easily carried out by unit armourers. For crossing aeroplanes the wire rectangle should be slightly above or below the horizontal, so as to appear to coincide with the line of flight of the aeroplane as shown by the line of flight rod.
- ii. The pole is held vertically in a wooden stand, or in a hole or socket in the ground.
- iii. The pole is made of stout bamboo or 2-in. by 2-in. scantling of sufficient length so that the nose of the aeroplane, when in the horizontal position, is 15 feet above ground level.

- iv. The aeroplane model is fixed on a spike on top of the pole. This spike is connected to the pole through an adjustable two-way knuckle joint fitted with bolts and wing nuts.
- v. The spike can be inclined at any angle within wide limits and the aeroplane may be slewed round on

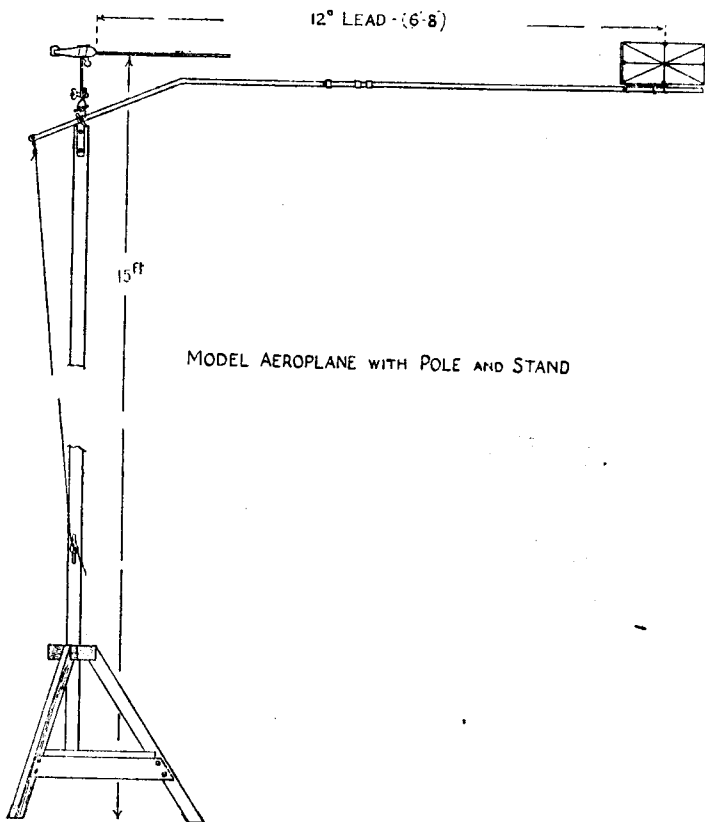

FIG. 11.

the spike so as to appear to be flying towards or away from the firer at any desired angle. The movable arm and rectangle, when in use, must always be at right angles to the firer's line of sight.

- vi. The arm which carries the rectangle is pivoted on the pole, so that it can be dropped while a rifle is

being laid on the target, and then raised so that the "lead" may be checked by comparison with the centre of the rectangle.

- vii. When in use, the foot of the pole should be nine yards distant from the centre of the rifle rest or tripod mounting, or the equivalent distance, about 10 yards from the firer's eye when the weapon is in the shoulder.

5. Spotlight projector. The apparatus consists of:—

- i. (a) A projector fitted with an electric bulb and a focusing device.

- (b) Brackets to attach the projector to:—

The rifle.

The light machine gun (Bren or Lewis according to the gun with which the unit is armed).

- (c) A D.P. rifle adapted for use with the projector.

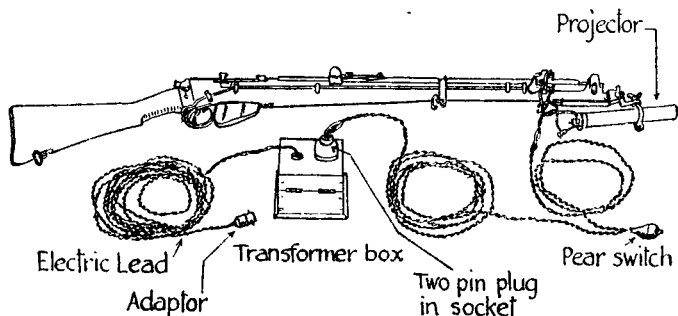

FIG. 12.—Showing all spotlight equipment fitted to the rifle.

- (d) A spare pistol grip, to which is fitted a switch device and an electric lead and two clips.

- (e) A transformer in a special box, with an electric lead fitted with an adaptor, and a two-pin socket. This box should not be opened.

- (f) An electric lead, fitted with a pear switch, two "spade" ends, two "pin" ends and a two-pin plug.

ii. The spotlight projector (*see* Fig. 12) is fitted to the special rifle as follows:—

- (a) Attach the bracket to the rifle on the bayonet boss and standard. Clamp the bracket firmly by tightening the wing nut between the bayonet boss and the standard.

- (b) Remove the spindle on the front of the bracket by unscrewing the wing nut, put the pivot of the projector between the wings of the bracket so that the

projector is under the barrel with the terminals towards the butt. Replace the spindle, passing it through the hole in the pivot of the projector, and screw it up firmly.

- (c) Attach the electric lead (i. (f) above) to the rifle and the projector. The two "spade" ends fit on to

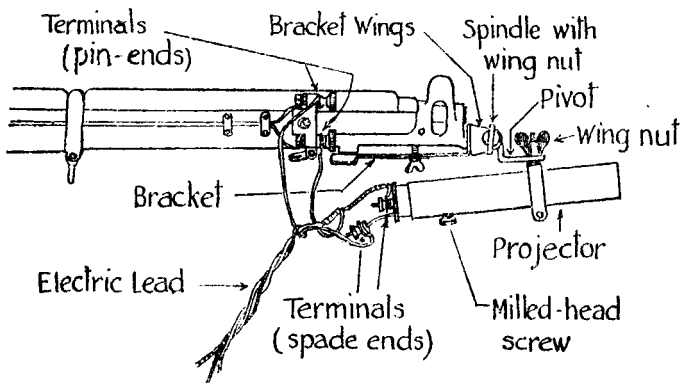

FIG. 13.—The projector fitted to muzzle of the rifle.

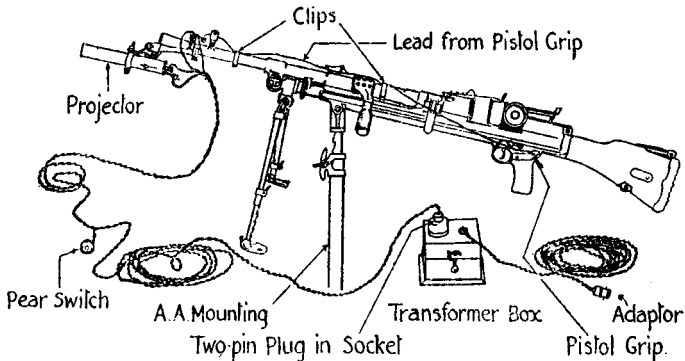

FIG. 14.—L.M.G. fitted with complete spotlight equipment.

terminals on the projector and the two "pin" ends on to the terminals on the rifle.

- (d) Insert the two-pin plug into the socket on the transformer box.
- (e) Having first ascertained that the controlling switch is off, remove the bulb from a convenient electric

light and insert the adaptor of the transformer. Switch on the current to the light, and the projector is ready for use. When the trigger is pressed or the pear switch is operated, a spot of light will be projected from the projector.

iii. The spotlight is fitted to the Bren gun as follows (see Fig. 14):—

- (a) The attachment is fitted to the pistol grip.
- (b) Attach the bracket to the muzzle of the Bren gun by unscrewing and removing the wing nut, slipping the hinged portion over the barrel and pushing it back until the ring of the bracket fits over the flash eliminator. Replace the wing nut and screw up firmly.
- (c) Fasten the lead from the pistol grip to the milled head

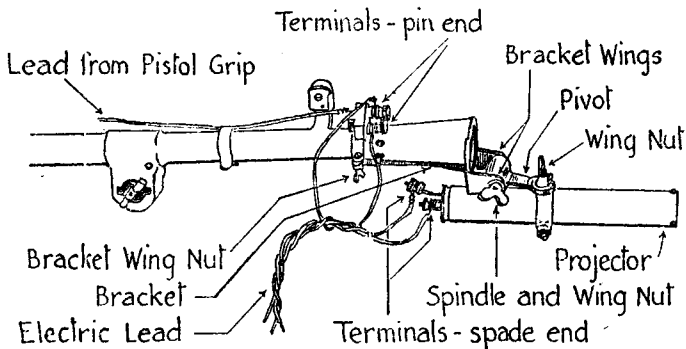

FIG. 15.—Projector fitted to muzzle of L.M.G.

screw on the rear of the block on the bracket and secure the lead to the top of the barrel with the two clips provided.

- (d) The projector is fitted to the bracket in the same manner as for the rifle. The electric lead is also connected in the same manner, except that the "pin" ends are in this case connected to the terminals on the bracket.
- (e) Continue as in ii. (d) and (e) above (see Fig. 15).

iv. The spotlight projector is fitted to the Lewis gun as follows:—

- (a) Replace the pistol grip on the gun with the special pistol grip issued for the spotlight projector.
- (b) Attach the spotlight projector bracket to the gun as follows:—

Insert the small end of the arm of the bracket under the sling swivel from the front so that the wings point towards the muzzle and the thickened portion of the small end is towards the radiator casing. Unscrew the clamping screw of the band and slide the band, with the heads of the two

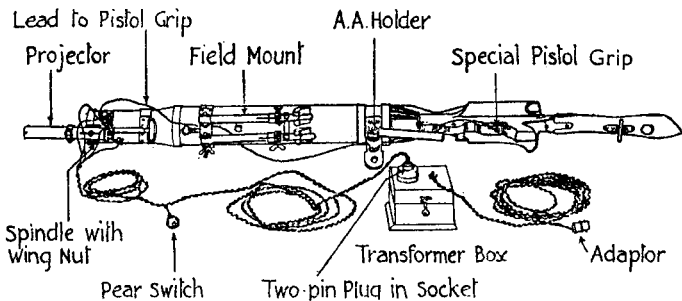

FIG. 16.—Lewis gun fitted with complete equipment.

terminals towards the butt, over the front radiator casing, pushing it back until the hole in the band corresponds with the hole in the arm of the bracket. Insert the clamping screw and clamp tightly.

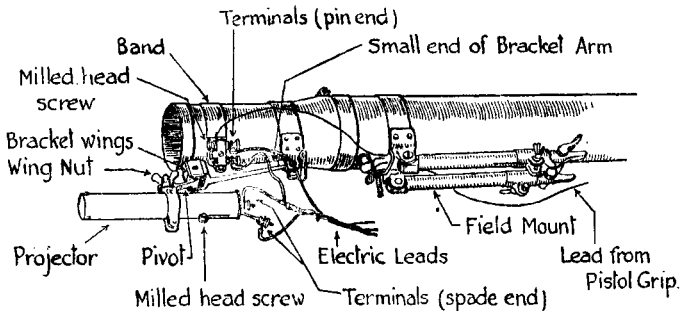

FIG. 17.

(c) Pass the lead from the trigger under the band of the A.A. holder and the field mount and attach it to the milled head screw on the front of the block on the bracket.

(d) As in iii (d) above.

(e) Continue as in iii (d) and (e) above (see Fig. 17).

v. The transformer is issued complete in its box with all necessary connections made. No alterations will be made

to the internal wiring of the box. Any necessary repairs must be made by an electrician.

vi. To focus the light from the projector, unscrew the small milled head screw under the barrel of the projector a few turns and slide this backwards and forwards until a small clear ring of light is thrown. Clamp by screwing tightly.

vii. To register the projector for aiming at diving and climbing targets, place the rifle in an aiming rest, slightly loosen the wing nut on the top of the projector and the wing nut on the wings of the bracket. Take a correct aim at a target and clamp the aiming rest firmly. Press the trigger and order an assistant to move the projector until the spot rests on the point of aim. Clamp the projector. Check correctness of registration and adjust as necessary.

viii. To register the projector for aiming at crossing aeroplanes, use two marks painted on the screen (*see* para. 6 (ii)) 6 ft. 8 in. apart. With the rifle on the rest or the gun on the tripod, order one man to aim at the left of the two marks and then register the light on the right-hand mark as in vii. above. The centre of the rest or tripod to be 10 yards from the screen.

6. Moving target for spotlight projector (*see* Fig. 18).

i. The target described below has been designed for use indoors with the spotlight projector. It is capable of a considerable range of speeds, which can be varied from $1\frac{1}{2}$ feet a second up to about 6 feet a second. In addition, it can be used at angles other than the horizontal, in order to give a diving effect to the target. It is easily reversible; only a short time is necessary to change the weights and reverse the model aeroplane.

The most suitable range at which to use the target is ten yards, both from the point of view of the spotlight projector and the best speed of the target.

The model aeroplane should be as light as possible. It should be 6 inches long and $8\frac{1}{2}$ -inch wing span. Stiff drawing paper is the best material for the purpose. The most suitable length of run is 20–24 feet, but this may have to be shortened when the run is not horizontal if insufficient vertical drop is available at one end of the run.

ii. **Description of target.**—Two front wheel hubs and spindles of an ordinary bicycle form the pulleys for the target. The oiling caps are removed. Round blocks of wood, with holes of the same diameter as that of the hubs of the wheels bored through their centres, are halved and glued in position on one half of the hubs. Three screws through the spoke holes retain the blocks in their correct positions. The pulleys

are then turned on a lathe to the shape and dimensions shown in Fig. 18.

The hubs are set opposite to one another in brackets. An endless cord of mattress thread is run round the two wooden

MOVING TARGET FOR SPOTLIGHT PROJECTOR

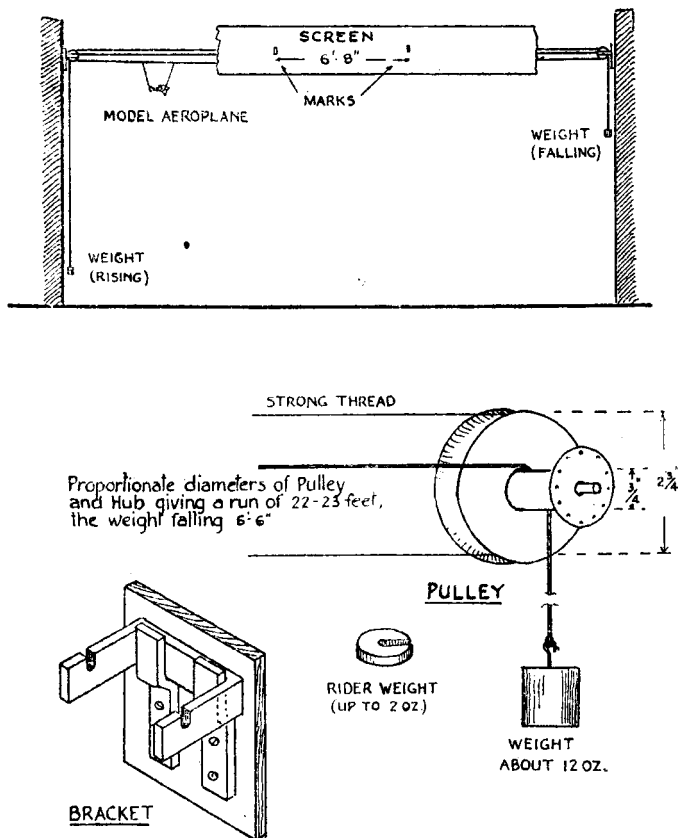

FIG. 18.—Moving target for spotlight projector.

pulleys, and the model aeroplane is hung on the lower thread. A second cord, also of mattress thread, is run over the metal part of the hubs, with two weights of 12 oz., each hung at

either end of the cord. The length of this cord should be adjusted so that, when one weight is resting on the ground, the other is against the stop close to the pulley.

A complete turn should not be taken round the hub with the weight cord; this introduces friction, and is quite unnecessary.

Screens should be erected in front to hide the mechanism and track, and behind to show up the spot.

iii. **Method of using target.**—

(a) See that the endless cord * is not too tight. A tight cord increases the friction in the hubs. The results of this are :—

(i) Jerky movement.

(ii) A large bias is required to move the model
(see (e) below).

(iii) It is impossible to run the target at a very low speed.

(b) See that plenty of play ($\frac{1}{16}$ inch) is allowed in the cones of the bearings, and that they are kept well oiled. If this is not done, the same defects as given under (a) above are obtained.

(c) Arrange the two 12-oz. weights so that one, called No. 1, is at the highest, and the other, called No. 2, is at the lowest point of its run.

(d) Fix the aeroplane to the lower part of the endless cord at the end near the No. 1 weight.

(e) Add rider weights to No. 1 weight until the aeroplane begins to move, then add two or more small rider weights until the aeroplane moves at a speed of $6\frac{1}{2}$ feet a second. With the gun at 10 yards range this represents an aeroplane at 400 yards travelling at 180 m.p.h. The number of small rider weights to be added will depend on the tension of the cord and the working condition of the hub and pulley. Adding weight to the No. 1 weight increases the speed. Adding weight to the No. 2 weight decreases the speed.

(f) After the run, return the aeroplane to its original position by pulling down No. 2 weight, not by lifting No. 1 weight.

(g) To reverse the direction of the run, reverse the aeroplane. The original No. 1 weight now becomes No. 2 weight, and *vice versa*.

* The tension of this cord varies to some degree with the weather.